



4-Wire Interfaced, 5 × 7 Matrix Vacuum-Fluorescent Display Controller

MAX6852

General Description

The MAX6852 compact vacuum-fluorescent display (VFD) controller provides microprocessors with the multiplex timing for 5 x 7 matrix VFD displays up to 96 characters and controls industry-standard, shift-register, high-voltage grid/anode VFD tube drivers. The device supports display tubes using either one or two digits per grid, as well as universal displays. The MAX6852 provides an internal crosspoint switch to match any tube-driver shift-register grid/anode order, and is compatible with both chip-in-glass and external tube drivers. Hardware is included to simplify the generation of cathode bias and filament supplies and to provide up to five logic outputs, including a buzzer driver.

The MAX6852 includes an ASCII 104-character font, multiplex scan circuitry, and static RAM that stores digit, cursor, and annunciator data, as well as font data for 24 user-definable characters. The display intensity can be adjusted by an internal 16-step digital brightness control. The device also includes separate annunciator and cursor control with automatic blinking, as well as a low-power shutdown mode.

The MAX6852 provides timing to generate the PWM waveforms to drive the tube filament from a DC supply. The filament drive is synchronized to the display multiplexing to eliminate beat artifacts. The MAX6852 is compatible with SPI™ and QSPI™.

For a 2-wire interfaced version, refer to the MAX6853 data sheet.

Applications

- Display Modules
- Retail POS Displays
- Weight and Tare Displays
- Bar Graph Displays
- Industrial Controllers

Pin Configuration and Functional Diagram appear at end of data sheet.

SPI and QSPI are trademarks of Motorola, Inc.

MICROWIRE is a trademark of National Semiconductor Corp.

Features

- ◆ High-Speed 26MHz SPI-/QSPI-/MICROWIRE™-Compatible Serial Interface
- ◆ 2.7V to 3.6V Operation
- ◆ Controls Up to 96 5 x 7 Matrix Characters
- ◆ One Digit and Two Digits per Grid and Universal Displays Supported
- ◆ 16-Step Digital Brightness Control
- ◆ Built-In ASCII 104-Character Font
- ◆ 24 User-Definable Characters
- ◆ Up to Four Annunciators per Grid with Automatic Blinking Control
- ◆ Separate Cursor Control with Automatic Blinking
- ◆ Filament Drive Full-Bridge Waveform Synthesis
- ◆ Buzzer Tone Generator with Single-Ended or Push-Pull Driver
- ◆ Up to Five General-Purpose Logic Outputs
- ◆ 9µA Low-Power Shutdown (Data Retained)
- ◆ 16-Pin QSOP Package

Ordering Information

PART	TEMP RANGE	PIN-PACKAGE
MAX6852AEE	-40°C to +125°C	16 QSOP

Typical Application Circuit

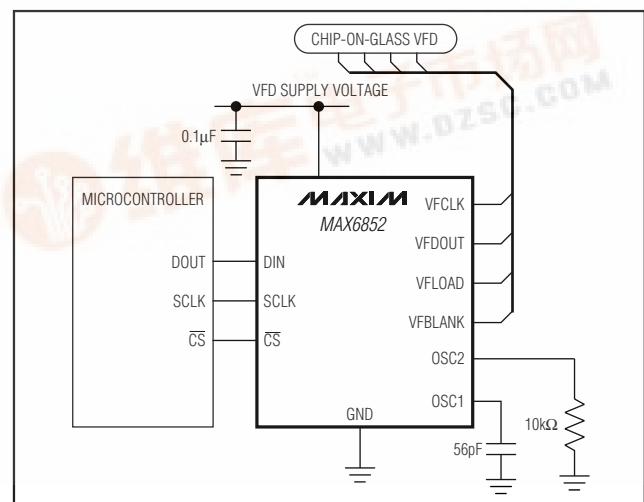

4-Wire Interfaced, 5 × 7 Matrix Vacuum-Fluorescent Display Controller

ABSOLUTE MAXIMUM RATINGS

Voltage (with respect to GND)

V+-0.3V to +4V

DIN, SCLK, \overline{CS} -0.3V to +5.5V

All Other Pins-0.3V to (V+ + 0.3V)

Current

V+200mA

GND-200mA

PHASE1, PHASE2, PORT0, PORT1, PUMP±150mA

VFCLK, VFDOOUT, VFLOAD, VFBLANK±150mA

Continuous Power Dissipation ($T_A = +70^\circ\text{C}$)

16-Pin QSOP (derate at 8.34mW/°C above +70°C)667mW

Operating Temperature Range (T_{MIN} , T_{MAX})

MAX6852AEE-40°C to +125°C

Junction Temperature+150°C

Storage Temperature Range-65°C to +150°C

Lead Temperature (soldering, 10s)+300°C

Stresses beyond those listed under "Absolute Maximum Ratings" may cause permanent damage to the device. These are stress ratings only, and functional operation of the device at these or any other conditions beyond those indicated in the operational sections of the specifications is not implied. Exposure to absolute maximum rating conditions for extended periods may affect device reliability.

DC ELECTRICAL CHARACTERISTICS

(Typical operating circuit, V+ = 2.7V to 3.6V, $T_A = T_{\text{MIN}}$ to T_{MAX} , unless otherwise noted.) (Note 1)

PARAMETER	SYMBOL	CONDITIONS	MIN	TYP	MAX	UNITS
Operating Supply Voltage	V+		2.7		3.6	V
Shutdown Supply Current	I _{SHDN}	Shutdown mode, all digital inputs at V+ or GND	$T_A = T_{\text{MIN}}$ to T_{MAX}		85	μA
				$T_A = +25^\circ\text{C}$	9	
Operating Supply Current	I+	OSC = 4MHz VFLOAD, VFDOOUT, VFCLK, VFBLANK, loaded 100pF	$T_A = T_{\text{MIN}}$ to T_{MAX}		3.5	mA
				$T_A = +25^\circ\text{C}$	0.71	
Master Clock Frequency (OSC Internal Oscillator)	f _{OSC}	OSC1 fitted with C _{OSC} = 56pF, OSC2 fitted with R _{OSC} = 10k Ω ; see the <i>Typical Operating Circuit</i>		4		MHz
Master Clock Frequency (OSC External Oscillator)		OSC1 overdriven with external f _{OSC}	2		8	MHz
Dead-Clock Protection Frequency				200		kHz
OSC High Time	t _{CH}		50			ns
OSC Low Time	t _{CL}		50			ns
Fast or Slow Segment Blink Duty Cycle		(Note 2)	49.5		50.5	%
LOGIC INPUTS AND OUTPUTS						
Input Leakage Current DIN, SCLK, \overline{CS}	I _{IH} , I _{IL}			0.2	1	μA
Logic-High Input Voltage DIN, SCLK, \overline{CS}	V _{IH}		2.4			V
Logic-Low Input Voltage DIN, SCLK, \overline{CS}	V _{IL}				0.6	V

4-Wire Interfaced, 5 × 7 Matrix Vacuum-Fluorescent Display Controller

MAX6852

DC ELECTRICAL CHARACTERISTICS (continued)

(Typical operating circuit, V+ = 2.7V to 3.6V, T_A = T_{MIN} to T_{MAX}, unless otherwise noted.) (Note 1)

PARAMETER	SYMBOL	CONDITIONS	MIN	TYP	MAX	UNITS
Output Rise and Fall Time PHASE1, PHASE2, PORT0, PORT1, PUMP, VFLOAD, VFDOUT, VFCLK, VFBLANK	trFT	C _{LOAD} = 100pF			25	ns
Output High-Voltage PHASE1, PHASE2, PORT0, PORT1, PUMP, VFLOAD, VFDOUT, VFCLK, VFBLANK	V _{OH}	I _{SOURCE} = 10mA	V+ - 0.6			V
Output Low-Voltage PHASE1, PHASE2, PORT0, PORT1, PUMP, VFLOAD, VFDOUT, VFCLK, VFBLANK	V _{OL}	I _{SINK} = 10mA			0.4V	V
Output Short-Circuit Source Current PHASE1, PHASE2, PORT0, PORT1, PUMP, VFLOAD, VFDOUT, VFCLK, VFBLANK	I _{OHSC}	Output programmed high, output short circuit to GND (Note 2)		62	125	mA
Output Short-Circuit Sink Current PHASE1, PHASE2, PORT0, PORT1, PUMP, VFLOAD, VFDOUT, VFCLK, VFBLANK	I _{OLSC}	Output programmed low, output short circuit to V+ (Note 2)		72	125	mA
4-WIRE SERIAL INTERFACE TIMING CHARACTERISTICS (Figure 6)						
SCLK Clock Period	t _{CP}		38.4			ns
SCLK Pulse Width High	t _{CH}		19			ns
SCLK Pulse Width Low	t _{CL}		19			ns
$\overline{\text{CS}}$ Fall to SCLK Rise Setup Time	t _{CSS}		9.5			ns
SCLK Rise to $\overline{\text{CS}}$ Rise Hold Time	t _{CSH}		5			ns
DIN Setup Time	t _{DS}		9.5			ns
DIN Hold Time	t _{DH}		2			ns
Minimum $\overline{\text{CS}}$ Pulse High	t _{CSW}		19			ns
DOUT Cascade Setup Time PORT0, PORT1	t _{CSU}	PORT0 and/or PORT1 enabled as DOUT	9.5			ns
VFD INTERFACE TIMING CHARACTERISTICS (Figure 9)						
VFCLK Clock Period	t _{VCP}	(Note 2)	250		1050	ns
VFCLK Pulse Width High	t _{VCH}	(Note 2)	125			ns
VFCLK Pulse Width Low	t _{VCL}	(Note 2)	125			ns
VFCLK Rise to VFD Load Rise Hold Time	t _{VCSH}	(Note 2)	19			μs
VFDOUT Setup Time	t _{VDS}	(Note 2)	50			ns
VFLOAD Pulse High	t _{VCSW}	(Note 2)	245			ns

Note 1: All parameters tested at T_A = +25°C. Specifications over temperature are guaranteed by design.

Note 2: Guaranteed by design.

4-Wire Interfaced, 5 × 7 Matrix Vacuum-Fluorescent Display Controller

Typical Operating Characteristics

(Typical operating circuit, $V_+ = 3.3V$, $T_A = +25^\circ C$, unless otherwise noted.)

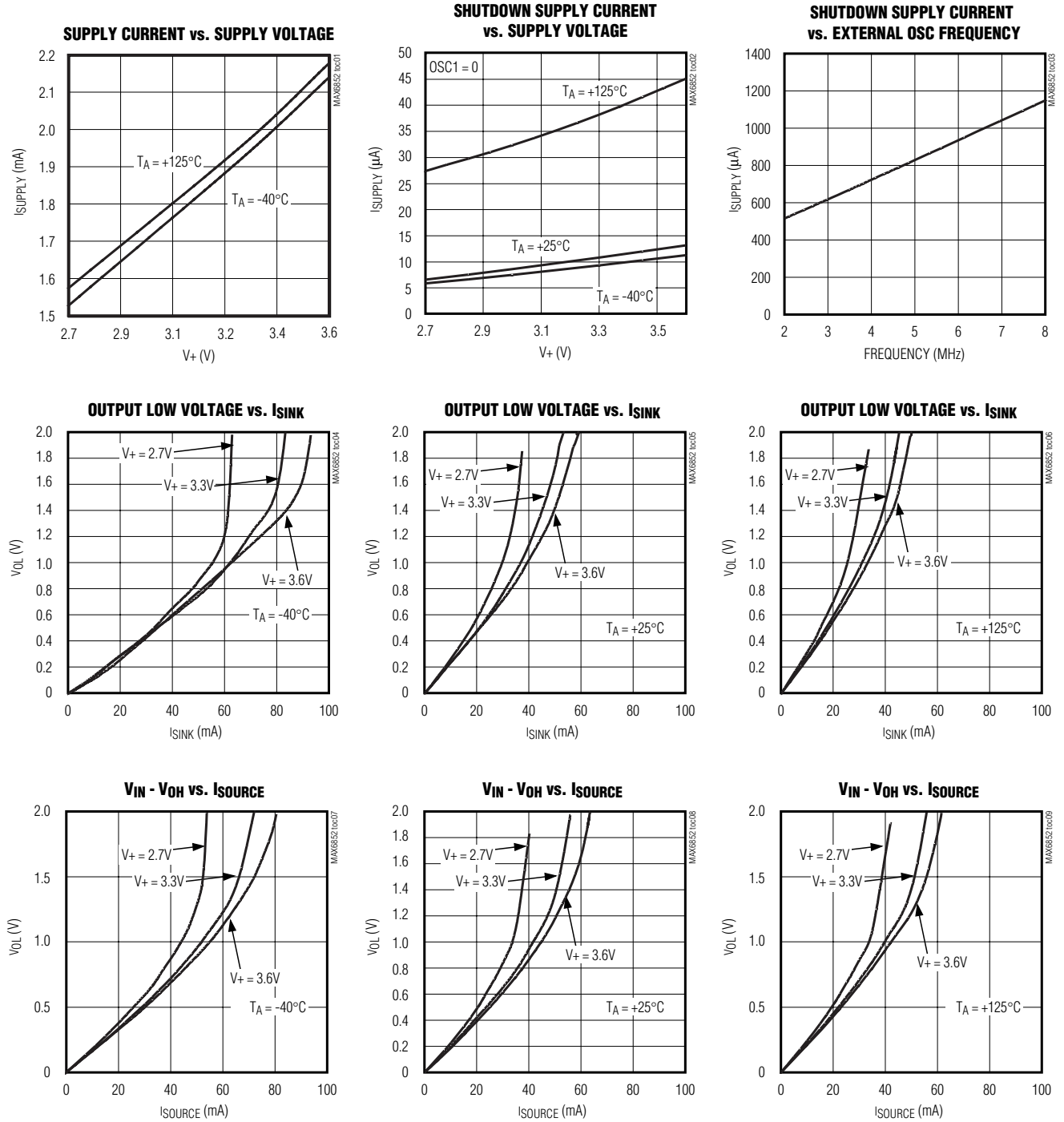

4-Wire Interfaced, 5 × 7 Matrix Vacuum-Fluorescent Display Controller

Typical Operating Characteristics (continued)

(Typical operating circuit, V+ = 3.3V, T_A = +25°C, unless otherwise noted.)

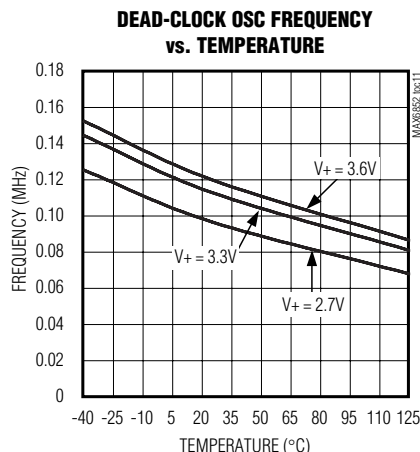
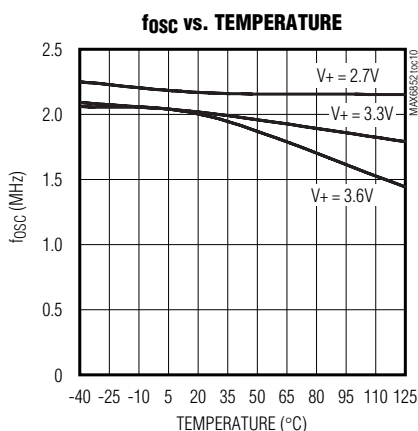

Pin Description

PIN	NAME	FUNCTION
1	VFCLK	Serial-Clock Output to External Driver. Push-pull clock output to external display driver. On VFCLK's falling edge, data is clocked out of VFDOOUT.
2	VFDOOUT	Serial-Data Output to External Driver. Push-pull data output to external display driver.
3	VFLOAD	Serial-Load Output to External Driver. Push-pull load output to external display driver. Rising edge is used by external display driver to load serial data into display latch.
4	VFBLANK	Display Blanking Output to External Driver. Push-pull blanking output to external display driver used for PWM intensity control.
5	PUMP	Charge-Pump Output and General-Purpose Output. User-configurable push-pull logic output can also be used as a driver for external charge pump.
6	PHASE1	Filament Drive PHASE1 Output and General-Purpose Output. User-configurable push-pull logic output can also be used as a driver for external filament bridge drive.
7	PHASE2	Filament Drive PHASE2 Output and General-Purpose Output. User-configurable push-pull logic output can also be used as a driver for external filament bridge drive.
8	V+	Positive Supply Voltage. Bypass V+ to GND with a 0.1μF ceramic capacitor.
9	GND	Ground
10	PORT0	PORT0 General-Purpose Output. User-configurable push-pull logic output.
11	SCLK	Serial-Clock Input. On SCLK's rising edge, data shifts into the internal shift register, and data is clocked out of DOUT. SCLK is active only while \overline{CS} is low.
12	DIN	Serial-Data Input. Data from DIN loads into the internal 16-bit shift register on SCLK's rising edge.
13	\overline{CS}	Chip-Select Input. Serial data is loaded into the shift register while \overline{CS} is low. The most recent 16 bits of data latch on \overline{CS} 's rising edge.
14	PORT1	PORT1 General-Purpose Output. User-configurable push-pull logic output.

4-Wire Interfaced, 5 × 7 Matrix Vacuum-Fluorescent Display Controller

Pin Description (continued)

PIN	NAME	FUNCTION
15	OSC1	Multiplex Clock Input 1. To use the internal oscillator, connect capacitor C _{OSC} from OSC1 to GND. To use the external clock, drive OSC1 with a 2MHz-to-8MHz CMOS clock.
16	OSC2	Multiplex Clock Input 2. Connect resistor R _{OSC} from OSC2 to GND.

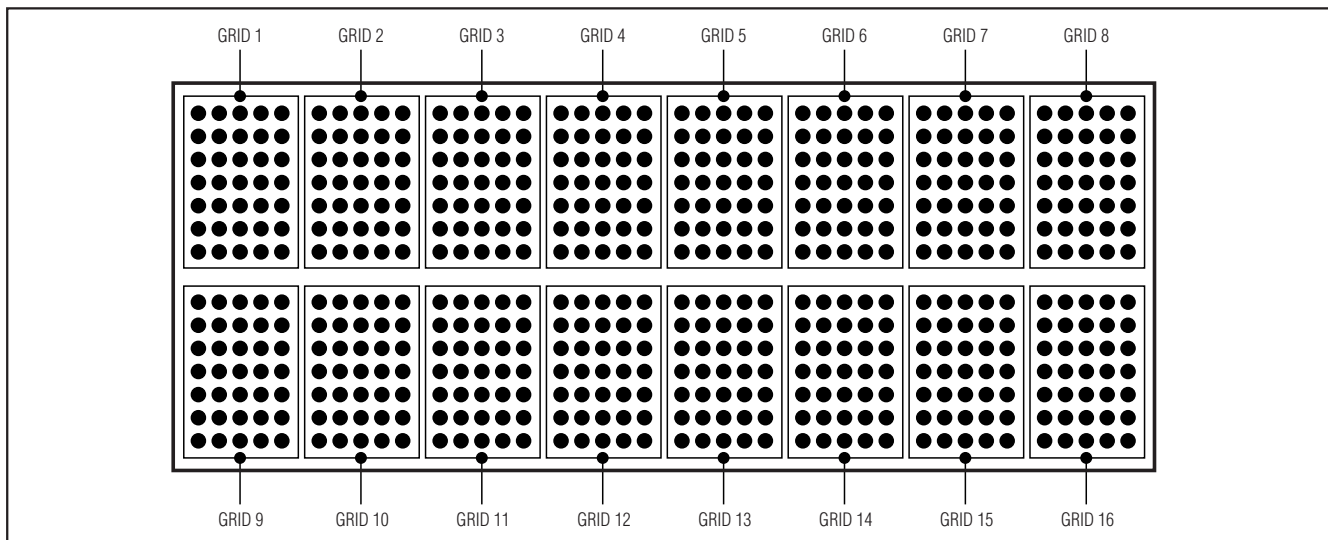

Figure 1. Example of a One-Digit-per-Grid Display

Detailed Description

Overview of the MAX6852

The MAX6852 VFD controller generates the multiplex timing for the following VFD display types:

- Multiplexed displays with one digit per grid, and up to 48 grids (in 48/1 mode). Each grid can contain one 5 × 7 matrix character, a decimal place (DP) segment, a cursor segment, and four extra annunciator segments (Figure 1).
- Multiplexed displays with two digits per grid, and up to 48 grids (in 96/2 mode). Each grid can contain two 5 × 7 matrix characters, two DP segments, and two cursor segments. No annunciator segments are supported (Figure 2).

Each digit can have a 5 × 7 matrix character, a DP segment, a cursor segment, and (for one-digit-per-grid displays only) four annunciators (Figure 3).

The 5 × 7 matrix character segments are not controlled directly, but use on-chip fonts that map the segments.

The fonts comprise an ASCII 104-character fixed-font set, and 24 user-definable characters. The predefined characters follow the Arial font, with the addition of the following common symbols: £, €, ¥, °, μ, ±, ↑, and ↓. The 24 user-definable characters are uploaded by the user into on-chip RAM through the serial interface and are lost when the device is powered down. As well as custom 5 × 7 characters, the user-definable fonts can control up to 35 custom segments, bar graphs, or graphics.

Annunciator segments have individual, independent control, so any combination of annunciators can be lit. Annunciators can be off, lit, or blink either in phase or out of phase with the cursor. The blink-speed control is software selectable to be one or two blinks per second (OSC = 4MHz).

DP segments can be lit or off, but have no blink control. A DP segment is set by the same command that writes the digit's 5 × 7 matrix character.

4-Wire Interfaced, 5 × 7 Matrix Vacuum-Fluorescent Display Controller

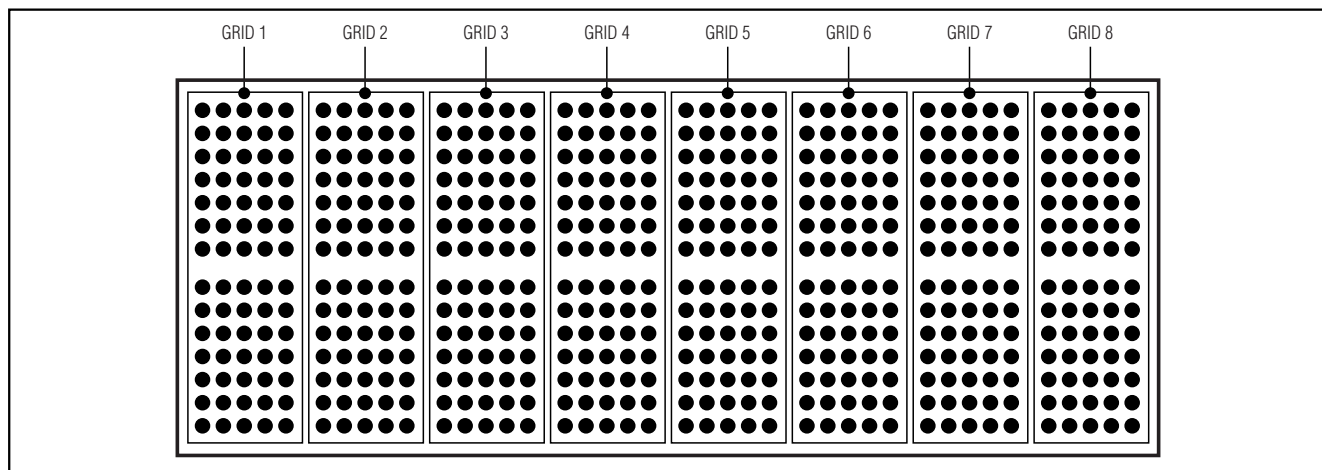

Figure 2. Example of a Two-Digits-per-Grid Display (8 Grids, 16 Digits)

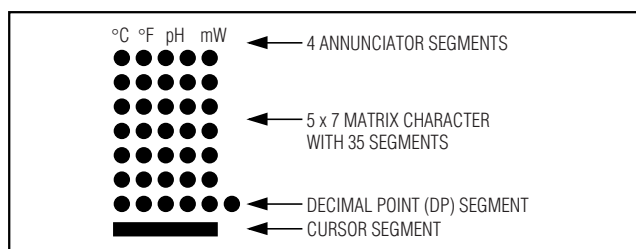

Figure 3. Digit Structure with 5 × 7 Matrix Character, DP Segment, Cursor Segment, Four Annunciators

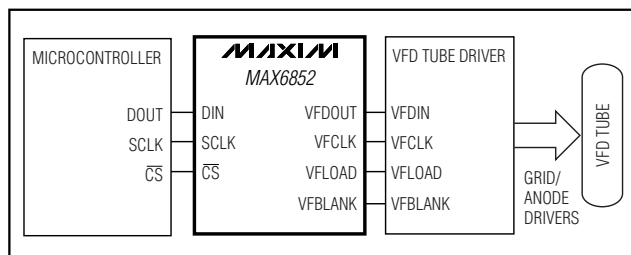

Figure 4. Connection of the MAX6852 to VFD Driver and VFD Tube

The cursor segment is controlled differently. A single register selects one digit's cursor from the entire display, and that can be lit either continuously or blinking. All the other digits' cursors are off.

The designations of DP, cursor, and annunciator are interchangeable. For example, consider an application requiring only one DP lit at a time, but the DP needs to blink. The DP function does not have blink capability. Instead, the DP segments on the display are routed (using the output map) to the cursor function. In this case, the DP segments are controlled using the cursor register.

The output of the controller is a 4-wire serial stream that interfaces to industry-standard, shift-register, high-voltage grid/anode VFD tube drivers (Figure 4). This interface uses three outputs to transfer and latch grid and anode data into the tube drivers, and a fourth output that enables/disables the tube driver outputs (Figure 5). The enable/disable control is modulated by the MAX6852 for both PWM intensity control and interdigit blanking, and disables the tube driver in shutdown. The

controller multiplexes the display by enabling each grid of the VFD in turn for 100 μ s (OSC = 4MHz) with the correct segment (anode) data. The data for the next grid is transferred to the tube drivers during the display time of the current grid.

The controller uses an internal output map to match any tube-driver's shift-register grid/anode order, and is therefore compatible with all VFD internal chip-in-glass or external tube drivers.

The MAX6852 provides five high-current output ports, which can be configured for a variety of functions:

The PUMP output can be configured as either an 80kHz (OSC = 4MHz) clock intended for DC-DC converter use, the 4-wire serial interface's DOUT data output, or a general-purpose logic output.

The PHASE1 and PHASE2 outputs can be individually configured as either 10kHz PWM outputs (OSC = 4MHz) intended for filament driving, blink status outputs, or general-purpose logic outputs.

4-Wire Interfaced, 5 × 7 Matrix Vacuum-Fluorescent Display Controller

The PORT0 and PORT1 outputs can be individually configured as either 625Hz, 1250Hz, or 2500Hz clocks (OSC = 4MHz) intended for buzzer driving, the 4-wire serial interface's DOUT data output, blink or shutdown status outputs, or general-purpose logic outputs.

Display Modes

The MAX6852 has two display modes (Table 1), selected by the M bit in the configuration register (Table 21). The display modes trade the maximum allowable number of digits (96/2 mode) against the availability of annunciator segments (48/1 mode). Table 2 is the register address map.

Initial Power-Up

On initial power-up, all control registers are reset, the display segment and annunciator data are cleared, intensity is set to minimum, and shutdown is enabled (Table 3).

Character Registers

The MAX6852 uses 48 character registers (48/1 mode) (Table 4) or 96 character registers (96/2 mode) (Table 5) to store the 5 × 7 characters (Table 6). Each digit is represented by 1 byte of memory. The data in the character registers does not control the character segments directly. Instead, the register data is used to address a character generator, which stores the data of the 128-character font (Table 7). The lower 7 bits of the character data (D6 to D0) select a character from the font table. The most significant bit (MSB) of the register data (D7) controls the DP segment of the digit; it is set to light the DP, cleared to leave it unlit.

The character registers address maps are shown in Table 4 (48/1 mode) and Table 5 (96/2 mode).

In 48/1 mode, the character registers use a single address range 0x20 to {0x20 + g}, where g is the value in the grids register (Table 24). The 48/1 mode upper address limit, when g is 0x2F, is therefore 0x4F. The address range 0x50 to 0x7F is used for annunciator data in 48/1 mode.

In 96/2 mode, the character registers use two address ranges. The first row's address range is 0x20 to {0x20 + g}. The second row's address range is 0x50 to {0x50 + g}. Therefore, in 96/2 mode, the character registers are only one contiguous memory range when a 48-grid display is used.

Character Generator Font Mapping

The font is a 5 × 7 matrix comprising 104 characters in ROM, and 24 user-definable characters. The selection from the total of 128 characters is represented by the

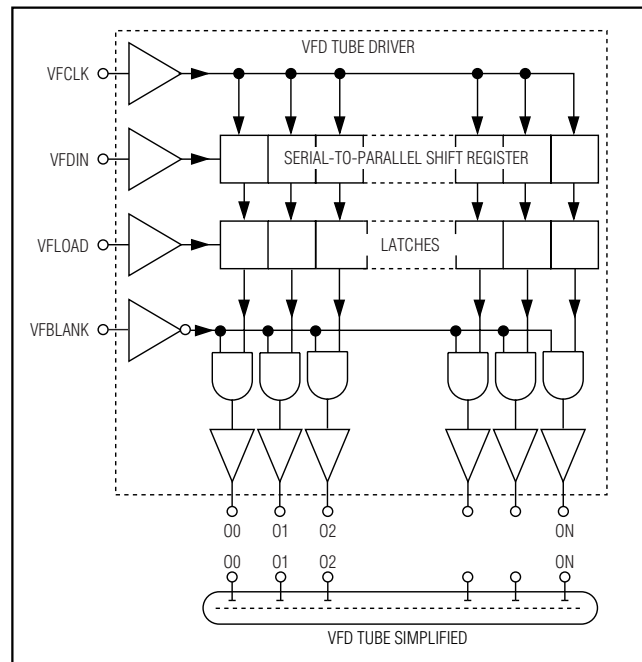

Figure 5. Block Diagram of VFD Tube Driver and VFD Tube

lower 7 bits of the 8-bit digit registers. The MSB, shown as x in the ROM map (Table 7), controls the DP segment of the digit; it is set to light the DP, cleared to leave it unlit.

The character map follows the Arial font for 96 characters in the x0100000 through x1111111 range. The first 32 characters map the 24 user-definable positions (RAM00 to RAM23), plus eight extra common characters in ROM.

User-Defined Fonts

The 24 user-definable characters are represented by 120 entries of 7-bit data, five entries per character, and are stored in the MAX6852's internal RAM.

The 120 user-definable font data entries are written and read through a single register, address 0x05. An autoincrementing font address pointer in the MAX6852 indirectly accesses the font data. The font address pointer can be written, setting one of 120 addresses between 0x00 and 0xF7, but cannot be read back. The font data is written to and read from the MAX6852 indirectly, using this font address pointer. Unused font locations can be used as general-purpose scratch RAM, noting that the font registers are only 7 bits wide, not 8.

4-Wire Interfaced, 5 × 7 Matrix Vacuum-Fluorescent Display Controller

MAX6852

Table 1. Display Modes

DISPLAY MODE	MAXIMUM NO. OF DIGITS	MAXIMUM NO. OF ANNUNCIATORS	MAXIMUM NO. OF GRIDS	DIGITS COVERED BY EACH GRID
48/1 mode	48 digits, each with a DP segment and a cursor segment	4 per digit	48 grids	1 digit per grid
96/2 mode	96 digits, each with a DP segment and a cursor segment	None		2 digits per grid

Table 2. Register Address Map

REGISTER	COMMAND ADDRESS								HEX CODE
	D15	D14	D13	D12	D11	D10	D9	D8	
No-op	R/W	0	0	0	0	0	0	0	0x00
VFBLANK polarity	R/W	0	0	0	0	0	0	1	0x01
Intensity	R/W	0	0	0	0	0	1	0	0x02
Grids	R/W	0	0	0	0	0	1	1	0x03
Configuration	R/W	0	0	0	0	1	0	0	0x04
User-defined fonts	R/W	0	0	0	0	1	0	1	0x05
Output map	R/W	0	0	0	0	1	1	0	0x06
Display test and device ID	R/W	0	0	0	0	1	1	1	0x07
PUMP register	R/W	0	0	0	1	0	0	0	0x08
Filament duty cycle	R/W	0	0	0	1	0	0	1	0x09
PHASE1	R/W	0	0	0	1	0	1	0	0x0A
PHASE2	R/W	0	0	0	1	0	1	1	0x0B
PORT0	R/W	0	0	0	1	1	0	0	0x0C
PORT1	R/W	0	0	0	1	1	0	1	0x0D
Shift limit	R/W	0	0	0	1	1	1	0	0x0E
Cursor	R/W	0	0	0	1	1	1	1	0x0F
Factory reserved. Do not write to register.	X	0	0	1	0	0	0	0	0x10

Table 8 shows how to use the single user-defined font register 0x05 to set the font address pointer, write font data, and read font data. A read action always returns font data from the font address pointer position. A write action sets the 7-bit font address pointer if the MSB is set, or writes 7-bit font data to the font address pointer position if the MSB is clear.

The font address pointer autoincrements after a valid access to the user-definable font data. Autoincrementing allows the 120-font data entries to be written and read back very quickly because the font pointer address need only be set once. After the last data location 0xF7 has

been written, further font data entries are ignored until the font address pointer is reset. If the font address pointer is set to an out-of-range address by writing data in the 0xF8 to 0xFF range, then address 0x80 is set instead (Table 9).

Table 10 shows the user-definable font pointer base addresses.

Table 11 shows an example of data (characters 0, 1, and 2) being stored in the first three user-defined font locations, illustrating the orientation of the data bits.

4-Wire Interfaced, 5 × 7 Matrix Vacuum-Fluorescent Display Controller

Table 3. Initial Power-Up Register Status

REGISTER	POWER-UP CONDITION	COMMAND ADDRESS	REGISTER DATA							
			D7	D6	D5	D4	D3	D2	D1	D0
VFBLANK polarity	VFBLANK is high to disable the display	0x01	X	X	X	X	X	X	0	0
Intensity	1/16 (min on)	0x02	X	X	X	X	0	0	0	0
Grids	Display has 1 grid	0x03	X	X	0	0	0	0	0	0
Configuration	Shutdown enabled, configuration unlocked	0x04	1	0	0	0	X	0	0	0
User-defined font address pointer	Address 0x80; pointing to the first user-defined font location	0x05	1	0	0	0	0	0	0	0
User-defined fonts	All 24 characters blank	—	0	0	0	0	0	0	0	0
Output map pointer	Pointing to first entry address	0x06	1	0	0	0	0	0	0	0
Output map data	Predefined for 40-digit display	—	See Table 30 for power-up patterns.							
Display test	Normal operation	0x07	X	X	X	X	X	X	X	0
PUMP	General-purpose output, logic	0x08	0	0	0	0	0	0	0	0
Filament duty cycle	Minimum duty cycle	0x09	0	0	0	0	0	0	0	1
PHASE1	General-purpose output, logic	0x0A	0	0	0	0	0	0	0	0
PHASE2	General-purpose output, logic	0x0B	0	0	0	0	0	0	0	0
PORT0	General-purpose output, logic	0x0C	0	0	0	0	0	0	0	0
PORT1	General-purpose output, logic	0x0D	0	0	0	0	0	0	0	1
Shift limit	1 output bit	0x0E	X	0	0	0	0	0	0	1
Cursor	Off	0x0F	0	1	1	0	0	0	0	0
Character and annunciator data	Clear	0x20	0	0	0	0	0	0	0	0
UP TO	—	UP TO	—	—	—	—	—	—	—	—
Character and annunciator data	Clear	0x7F	0	0	0	0	0	0	0	0

Table 12 shows the six sequential write commands required to set a MAX6852's font character RAM02 with the data to display character 2 given in Table 7.

Cursor Register

The cursor register controls the behavior of the cursor segments (Table 13). The MAX6852 controls 48 cursors in 48/1 mode, and 96 cursors in 96/2 mode. The cursor register selects one digit's cursor to be lit either continuously or blinking. All the other digits' cursors are off.

The 7 least significant bits (LSBs) of the cursor register identify the cursor position. The MSB is clear for the cursor to be on continuously, and set for the cursor to be lit only during the first half of each blink period.

The valid cursor position address range is contiguous: 0 to 47 (0x00 to 0x2F) for the 1st digit row, and 48 to 95 (0x30 to 0x5F) for the 2nd digit row. If the cursor regis-

ter is programmed with an out-of-range value of 95 to 127 (0x60 to 0x7F), then all cursors are off.

Annunciator Registers

The annunciator registers are organized in bytes, with each segment of each grid being represented by 2 bits. Thus, the four annunciators segments allowed for each grid are represented by exactly 1 byte (Table 14). Annunciators are only available in 48/1 mode. The annunciator address map is shown in Table 4.

Configuration Register

The configuration register is used to enter and exit shutdown, lock the key VFD configuration settings, select the blink rate, globally clear the digit and annunciator data, reset the blink timing, and select between 48/1 and 96/2 display modes (Table 15).

4-Wire Interfaced, 5 × 7 Matrix Vacuum-Fluorescent Display Controller

MAX6852

Table 4. Character and Annunciator Register Address Map in 48/1 Mode

REGISTER	COMMAND ADDRESS								HEX CODE
	D15	D14	D13	D12	D11	D10	D9	D8	
Digit 0 5 x 7 matrix character	R/W	0	1	0	0	0	0	0	0x20
Digit 1 5 x 7 matrix character	R/W	0	1	0	0	0	0	1	0x21
Digit 2 5 x 7 matrix character	R/W	0	1	0	0	0	1	0	0x22
UP TO	—	—	—	—	—	—	—	—	—
Digit 45 5 x 7 matrix character	R/W	1	0	0	1	1	0	1	0x4D
Digit 46 5 x 7 matrix character	R/W	1	0	0	1	1	1	0	0x4E
Digit 47 5 x 7 matrix character	R/W	1	0	0	1	1	1	1	0x4F
Digit 0 annunciators	R/W	1	0	1	0	0	0	0	0x50
Digit 1 annunciators	R/W	1	0	1	0	0	0	1	0x51
Digit 2 annunciators	R/W	1	0	1	0	0	1	0	0x52
UP TO	—	—	—	—	—	—	—	—	—
Digit 45 annunciators	R/W	1	1	1	1	1	0	1	0x7D
Digit 46 annunciators	R/W	1	1	1	1	1	1	0	0x7E
Digit 47 annunciators	R/W	1	1	1	1	1	1	1	0x7F

Table 5. Character Register Address Map in 96/2 Mode

REGISTER	COMMAND ADDRESS								HEX CODE
	D15	D14	D13	D12	D11	D10	D9	D8	
Digit 0 5 x 7 matrix character, 1st row	R/W	0	1	0	0	0	0	0	0x20
Digit 1 5 x 7 matrix character, 1st row	R/W	0	1	0	0	0	0	1	0x21
Digit 2 5 x 7 matrix character, 1st row	R/W	0	1	0	0	0	1	0	0x22
UP TO	—	—	—	—	—	—	—	—	—
Digit 45 5 x 7 matrix character, 1st row	R/W	1	0	0	1	1	0	1	0x4D
Digit 46 5 x 7 matrix character, 1st row	R/W	1	0	0	1	1	1	0	0x4E
Digit 47 5 x 7 matrix character, 1st row	R/W	1	0	0	1	1	1	1	0x4F
Digit 0 5 x 7 matrix character, 2nd row	R/W	1	0	1	0	0	0	0	0x50
Digit 1 5 x 7 matrix character, 2nd row	R/W	1	0	1	0	0	0	1	0x51
Digit 2 5 x 7 matrix character, 2nd row	R/W	1	0	1	0	0	1	0	0x52
UP TO	—	—	—	—	—	—	—	—	—
Digit 45 5 x 7 matrix character, 2nd row	R/W	1	1	1	1	1	0	1	0x7D
Digit 46 5 x 7 matrix character, 2nd row	R/W	1	1	1	1	1	1	0	0x7E
Digit 47 5 x 7 matrix character, 2nd row	R/W	1	1	1	1	1	1	1	0x7F

4-Wire Interfaced, 5 × 7 Matrix Vacuum-Fluorescent Display Controller

Table 6. Character Registers Format

MODE	COMMAND ADDRESS	REGISTER DATA								
		D7	D6	D5	D4	D3	D2	D1	D0	
Writing character data to use font map data with DP segment unlit	0x20 to 0x4F (48/1 mode) 0x20 to 0x7F (96/2 mode)	0	Bits D6 to D0 select font characters 0 to 127							
Writing character data to use font map data with DP segment lit	0x20 to 0x4F (48/1 mode) 0x20 to 0x7F (96/2 mode)	1	Bits D6 to D0 select font characters 0 to 127							

Shutdown Mode (S Data Bit D0) Format

The S bit in the configuration register selects shutdown or normal operation (Table 16). The display driver can be programmed while in shutdown mode, and shutdown mode is overridden when in display test mode. For normal operation, set S bit to 1.

When the MAX6852 is in shutdown mode, the multiplex oscillator is halted at the end of the current 100μs multiplex period (OSC = 4MHz), and the VFBLANK output is used to disable the VFD tube driver. Data in the digit and other control registers remains unaltered.

If the PUMP output is configured as a square-wave clock, then the PUMP output is forced low for the duration of shutdown, and the square-wave clock restored when the MAX6852 comes out of shutdown.

If the PHASE1 output or PHASE2 output is configured as a filament driver, then that output is forced low for the duration of shutdown and the filament drive waveforms restored when the MAX6852 comes out of shutdown.

When the MAX6852 comes out of shutdown, the external VFD tube driver is presumed to contain invalid data. The VFBLANK output is used to disable the VFD tube driver for the first multiplex cycle after exiting shutdown, clearing any invalid data. The next multiplex cycle uses newly sent valid data.

Configuration Lock (L Data Bit D1) Format

The configuration lock register is a safety feature to reduce the risk of the VFD configuration settings being inadvertently changed due to spurious writes if software fails. When set, the shift-limit register (0x0E), grids register (0x03), and output map data (0x06) can be read but cannot be written. The output map data pointer itself may be written in order to allow the output map data to be read back (Table 17).

Blink Rate Selection (B Data Bit D2) Format

The B bit in the configuration register selects the blink rate of the cursor and annunciator segments. This is the speed that the segments blink on and off when blinking

is selected for these segments. The frequency of the multiplex clock OSC and the setting of the B bit (Table 18) determine the blink rate.

Global Blink Timing Synchronization (T Data Bit D4) Format

Setting the T bit in multiple MAX6852s at the same time (or in quick succession) synchronizes the blink timing across all the devices (Table 19). The display multiplexing sequence is also reset, which can give rise to a one-time display flicker when the register is written.

Global Clear Digit Data (R Data Bit D5) Format

When the R bit (Table 20) is set, the segment and annunciator data are cleared.

Display Mode (M Data Bit D6) Format

The M bit (Table 21) selects the display modes (Table 1). The display modes trade maximum allowable number of digits (mode 96/2) against the availability of annunciator segments (mode 48/1).

Blink Phase Readback (P Data Bit D7) Format

When the configuration register is read, the P bit reflects the blink phase pin at that time (Table 22).

Microcontroller 4-Wire Serial Interface

The MAX6852 communicates through an SPI-compatible 4-wire serial interface (Figure 6). The interface has three inputs, clock (SCLK), chip select (\overline{CS}), data in (DIN), and output data out (DOUT). \overline{CS} must be low to clock data into or out of the device, and DIN must be stable when sampled on the rising edge of SCLK. DOUT is not a specific pin, but instead, any of the PUMP, PORT0, or PORT1 outputs can be configured to be DOUT. DOUT is stable on the rising edge of SCLK. While the SPI protocol expects DOUT to be high impedance when the MAX6852 is not being accessed, DOUT on the MAX6852 is never high impedance. SCLK and DIN can be used to transmit data to other peripherals. The MAX6852 ignores all activity on SCLK and DIN except when \overline{CS} is low.

4-Wire Interfaced, 5 × 7 Matrix Vacuum-Fluorescent Display Controller

MAX6852

Control and Operation Using the 4-Wire Interface

Controlling the MAX6852 requires sending a 16-bit word. The first byte, D15 through D8, is the command address, and the second byte, D7 through D0, is the data to be written to the command address (Table 23).

Connecting Multiple MAX6852s to the 4-Wire Bus

Daisy-chain multiple MAX6852s by connecting the DOUT of one device to the DIN of the next, and driving SCLK and CS lines in parallel. Data at DIN propagates through the internal shift registers and appears at DOUT 15.5 clock cycles later, clocked out on the rising edge of SCLK. When sending commands to daisy-chained MAX6852s, all devices are accessed at the same time. An access requires (16 × n) clock cycles, where n is the number of MAX6852s connected together. To update just one device in a daisy-chain, send the no-op command (0x00) to the others. Care must be taken on power-up when daisy-chaining the serial interface in this manner. Configure each MAX6852's PORT0 or PORT1 outputs, in turn, to act as DOUT before data propagates through it. For this reason, PORT0 is the preferred output to configure as DOUT because its output on power-up is low. This means that a daisy-chained DIN input taking data from an uninitialized PORT0 output clocks in 16 logic zeros, which is the safe no-op instruction.

Writing Device Registers

The MAX6852 contains a 16-bit shift register into which DIN is clocked on the rising edge of SCLK, when CS is low. When CS is high, transitions on SCLK have no effect. When CS goes high, the 16 bits in the shift register are parallel loaded into a 16-bit latch. The 16 bits in the latch are then decoded and executed.

The MAX6852 is written to using the following sequence:

- 1) Take SCLK low.
- 2) Take CS low. This enables the internal 16-bit shift register.
- 3) Clock 16 bits of data into DIN, D15 first to D0 last, observing the setup and hold times. Bit D15 is low, indicating a write command.
- 4) Take CS high (while SCLK is still high after clocking in the last data bit).
- 5) Take SCLK low.

Figure 7 shows a write operation when 16 bits are transmitted.

Table 7. Character Map

MSB LSB	x000	x001	x010	x011	x100	x101	x110	x111
0000	RAM00	RAM16						
0001	RAM01	RAM17						
0010	RAM02	RAM18						
0011	RAM03	RAM19						
0100	RAM04	RAM20						
0101	RAM05	RAM21						
0110	RAM06	RAM22						
0111	RAM07	RAM23						
1000	RAM08							
1001	RAM09							
1010	RAM10							
1011	RAM11							
1100	RAM12							
1101	RAM13							
1110	RAM14							
1111	RAM15							

4-Wire Interfaced, 5 × 7 Matrix Vacuum-Fluorescent Display Controller

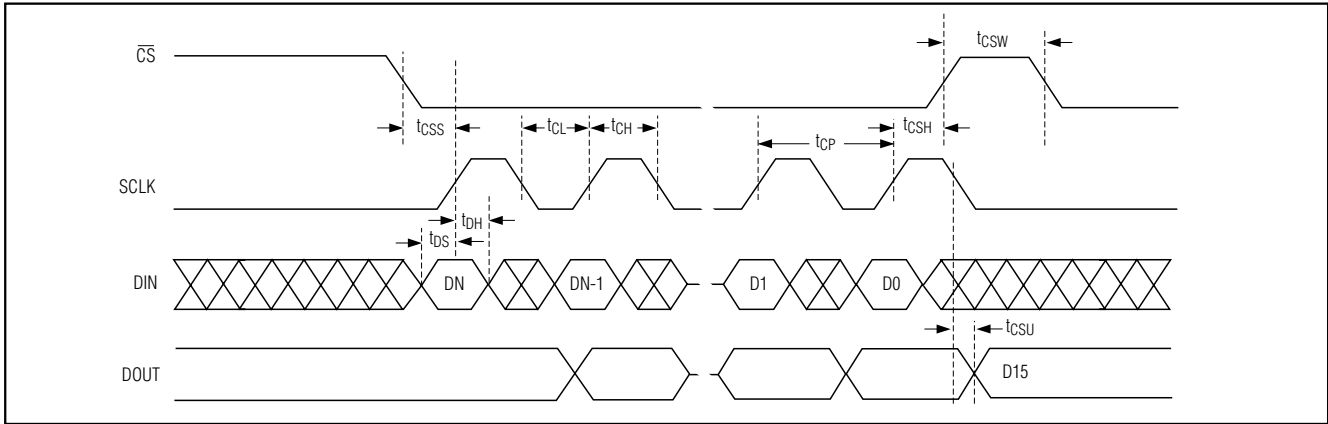

Figure 6. 4-Wire Serial Interface Timing Diagram

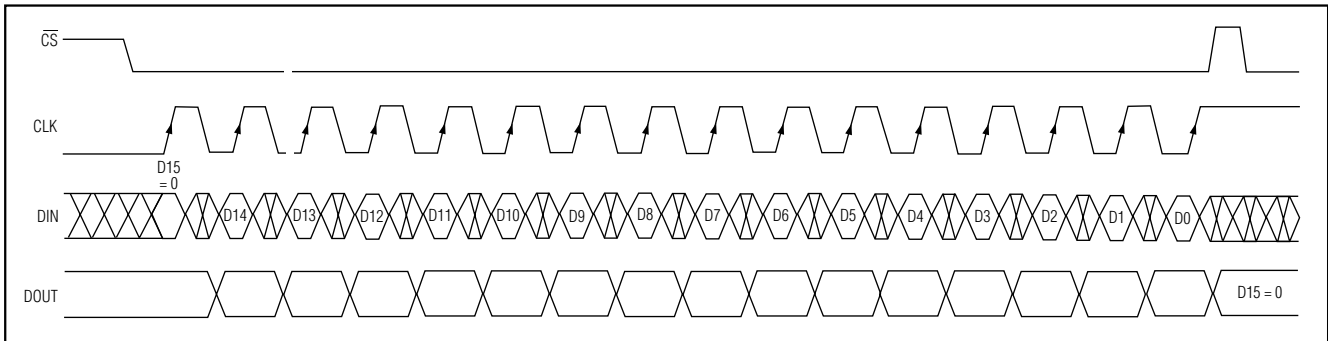

Figure 7. 16-Bit Write Transmission to the MAX6852

If fewer or greater than 16 bits are clocked into the MAX6852 between taking \overline{CS} low and taking \overline{CS} high again, the MAX6852 stores the last 16 bits received, including the previous transmission(s). The general case is when n bits (where $n > 16$) are transmitted to the MAX6852. The last bits comprising bits $\{n-15\}$ to $\{n\}$ are retained and are parallel loaded into the 16-bit latch as bits D15 to D0, respectively (Figure 8).

Reading Device Registers

Any register data within the MAX6852 may be read by sending a logic high to bit D15. The sequence is:

- 1) Take SCLK low.
- 2) Take \overline{CS} low. This enables the internal 16-bit shift register.
- 3) Clock 16 bits of data into DIN, D15 first to D0 last, observing the setup and hold times. Bit D15 is high, indicating a read command, and bits D14 through

D8 contain the address of the register to read. Bits D7 to D0 contain dummy data, which is discarded.

- 4) Take \overline{CS} high. Positions D7 through D0 in the shift register are now loaded with the data in the register addressed by bits D15 through D8.
- 5) Take SCLK low.
- 6) Issue another read or write command (which can be no-op), and examine the bit stream at DOUT; the first 8 bits contain the address of the register that was read (**Note:** The MSB, which was transmitted as a 1 for a read command, may read back either as a 1 or a zero). The second 8 bits are the contents of the register addressed by bits D14 through D8 in Step 3.

VFD Driver Serial Interface

The VFD driver interface on the MAX6852 is a serial interface using three output pins, VFLOAD, VFCLK, and VFDOOUT (Figure 9) to drive industry-standard, shift-reg-

4-Wire Interfaced, 5 × 7 Matrix Vacuum-Fluorescent Display Controller

MAX6852

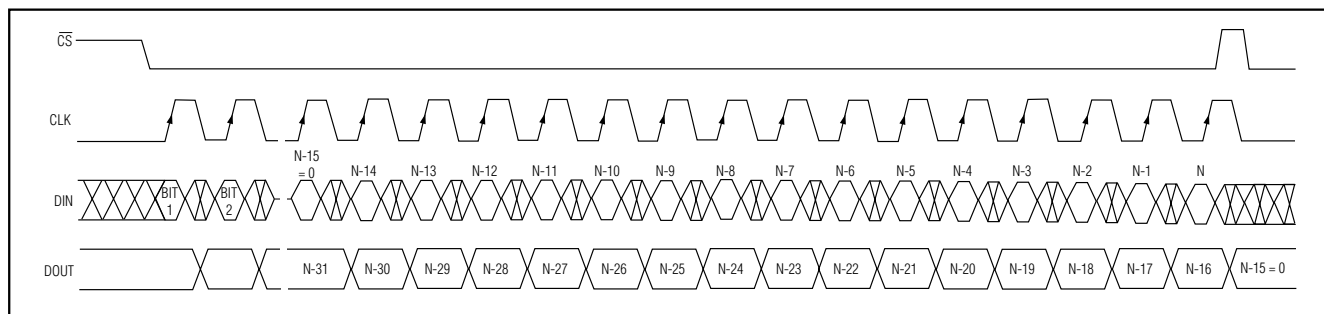

Figure 8. Transmission of More than 16 Bits to the MAX6852

ister, high-voltage grid/anode VFD tube drivers (Figures 3 and 4). The speed of VFCLK is 2MHz when OSC is 4MHz. The maximum speed of VFCLK is 4MHz when OSC is 8MHz. This interface is used to transfer display data from the MAX6852 to the VFD tube driver. The serial interface bit stream output is programmable up to 122 bits, which are labeled DD0–DD121.

The functions of the three interface pins are as follows: VFCLK is the serial clock output, which shifts data on its falling edge from the MAX6852's 122-bit output shift register to VFLOAD.

VFDOOUT is the serial data output. The data changes on VFCLK's falling edge, and is stable when it is sampled by the display driver on the rising edge of VFCLK.

VFLOAD is the latch-load output. VFLOAD is high to transfer data from the display tube driver's shift register to the display driver's output latch (transparent mode), and low to retain that data in the display driver's output latch.

A fourth output pin, VFBLANK, provides gating control of the tube driver. VFBLANK can be configured to be either high or low using the VBLANK polarity register (Table 26) to enable the VFD tube driver. In the default condition, VFBLANK is high to disable the VFD tube driver, which is expected to force its driver outputs low to blank the display without altering the contents of its output latches. In the default condition, VFBLANK is low to enable its VFD tube driver outputs to follow the state of the VFD tube driver's output latches. The VFBLANK output is used for PWM intensity control and to disable the VFD tube driver in shutdown.

Multiplex Architecture

The multiplex engine transmits grid and anode control data to the external VFD driver using the VFCLK, VFDOOUT, and VFLOAD. The number of data bits m transmitted is set by the user in the shift-limit register (Table 28). Figure 10 is the VFD multiplex timing diagram.

The essential rules for multiplex action are as follows:

- The external VFD driver's data latch contains the data for the current grid being displayed.
- The VFBLANK input is controlled to provide the PWM intensity control.
- The VFCLK and VFDOOUT outputs are used to fill the external VFD driver's shift register with the multiplex data for the next grid, during the multiplex timeslot for the current grid.
- The VFLOAD output loads the new grid-anode data pattern at the start of its multiplex cycle.

Grids Register

The grids register sets how many grids are multiplexed from 1 to 48 (Table 24).

When the grids register is written, the external VFD tube driver is presumed to contain invalid data. The VFBLANK output is used to disable the VFD tube driver for the first multiplex cycle after exiting shutdown, clearing any invalid data. The next multiplex cycle uses newly sent, valid data. If the grids register is written with an out-of-range value of 0x30 to 0xFF, then the value 0x2F is stored instead.

Intensity Register

Digital control of display brightness is provided by pulse-width modulation of the tube blanking time, which is controlled by the lower nibble of the intensity register (Table 25). The modulator scales the VFBLANK output in 15 steps from a minimum of 1/16 up to 15/16 of each grid's multiplex period (Figure 11). Figure 12 shows the modulator behavior when the VFBLANK polarity register is set to 0x00 (Table 26), so VFBLANK is high to disable (blank) the display.

The minimum off-time period of a 1/16 multiplex period (6.25 μ s with OSC = 4MHz) is always at the start of the multiplex cycle. This allows time for slow display drivers to turn off, and slow display phosphors time to decay

4-Wire Interfaced, 5 × 7 Matrix Vacuum-Fluorescent Display Controller

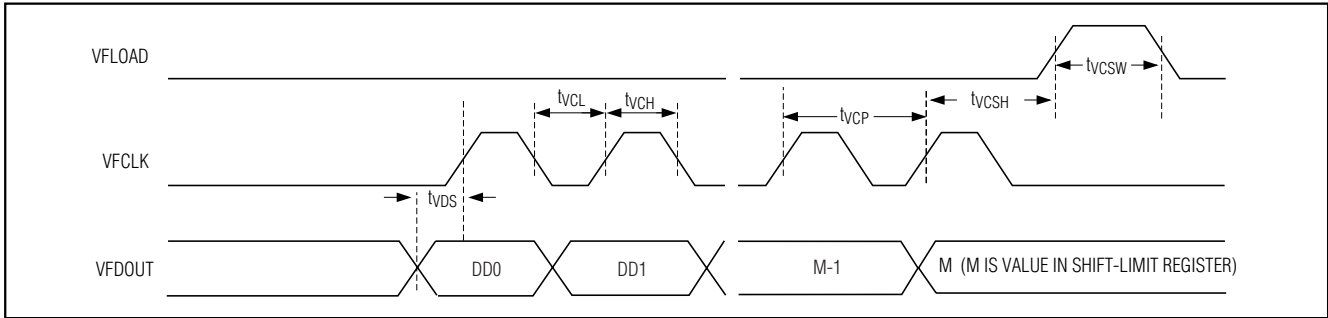

Figure 9. VFD Interface Timing Diagram

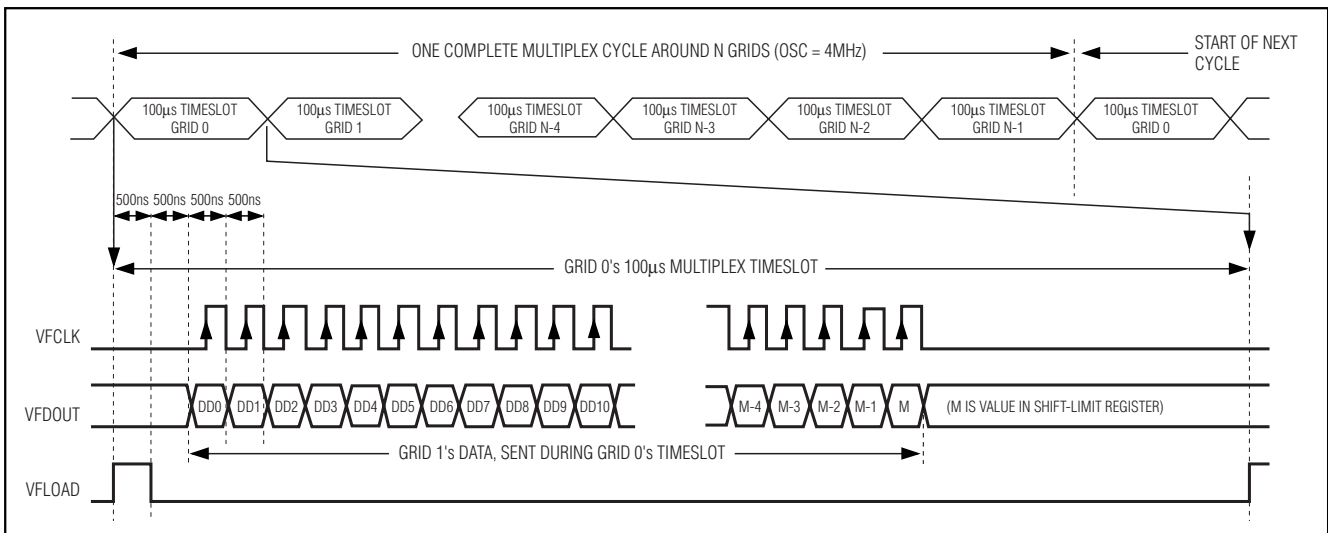

Figure 10. VFD Multiplex Timing Diagram

between grids. Thus, image ghosting is avoided. If a display has very slow phosphor, then the allowed decay time can be doubled by not using a 15/16 duty cycle.

VFBLANK Polarity Register

The VFBLANK polarity register sets the active level of the VFBLANK output pin (Table 26).

No-Op Register

A write to the no-op register is ignored.

Display-Test and Device ID Register

Writing the display-test and device ID register switches the drivers between one of two modes: normal and display test. Display-test mode turns all segments and annunciators on and sets the duty cycle to 7/16 (half-power) (Table 27).

Reading the display-test and device ID register returns the MAX6852 device ID 0b0000 011 that identifies the driver type, plus the display-test status in the LSB.

Output Shift-Limit Register

The output serial interface is used to transfer display data from the MAX6852 to the display driver. The serial interface bit-stream output length is programmable up to 122 bits, which are labeled DD0–DD121. Set the number of bits with the shift-limit register, address 0x0E. If the shift-limit register is written with an out-of-range value 0x7A to 0xFF, then the value 0x79 is stored instead. Table 28 shows the shift-limit register.

Output Map

The output map comprises 122 words of 7-bit RAM. The output map data should be written when the MAX6852 is configured after power-up. Table 29 shows the output map RAM codes.

4-Wire Interfaced, 5 × 7 Matrix Vacuum-Fluorescent Display Controller

MAX6852

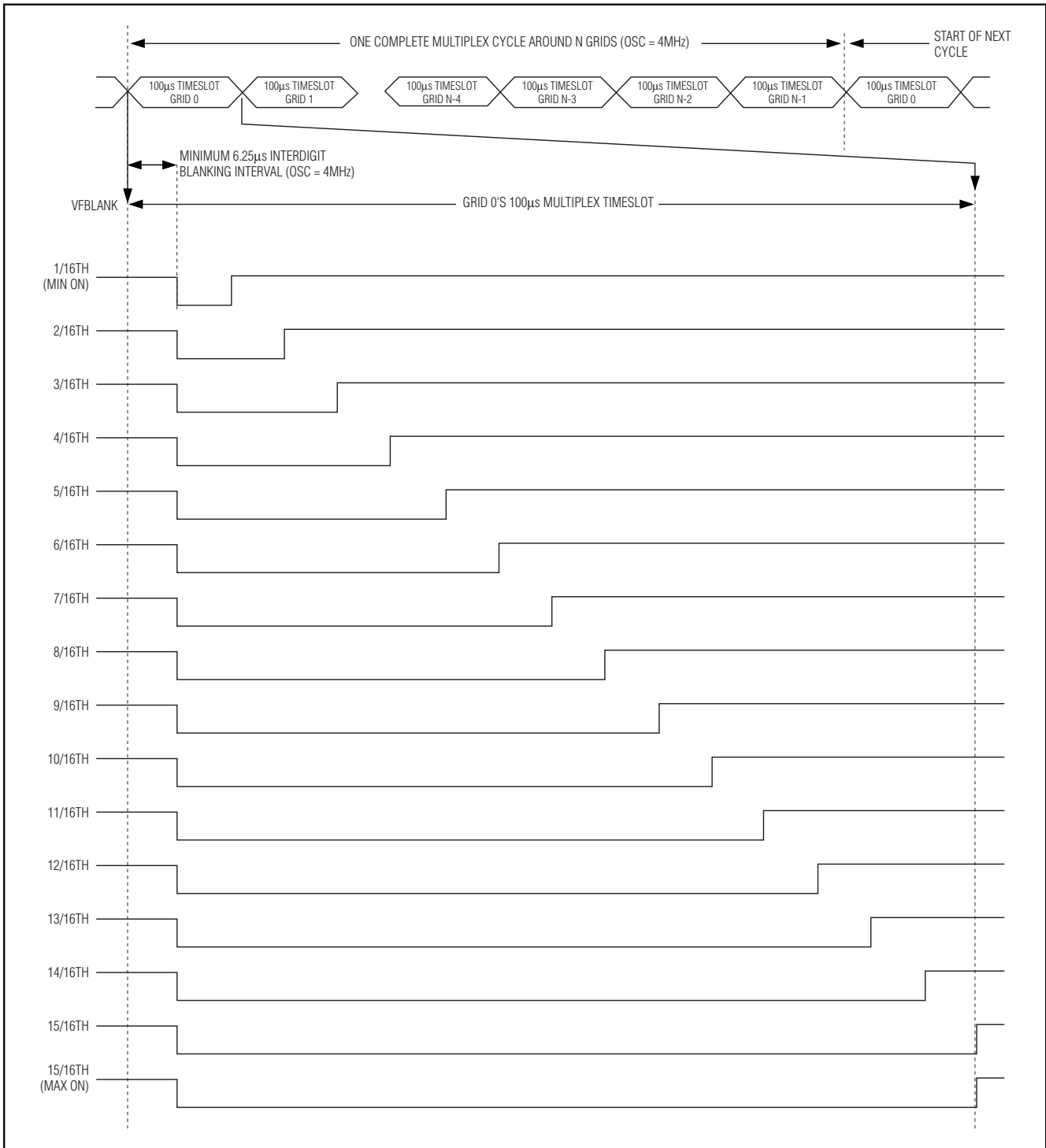

Figure 11. BLANK and Intensity Timing Diagram

4-Wire Interfaced, 5 × 7 Matrix Vacuum-Fluorescent Display Controller

The output map is an indirect addressing reference table. It translates bit position in the output shift register (valid range: from zero to the value in shift-limit register 0x0E) to bit function. Any output shift-register bit position may be set to any grid, 5 x 7 matrix segment, DP segment, annunciator segment, or cursor segment.

The power-up default pattern for output map RAM maps a 40-digit, two-digits-per-grid display with DPs and cursors (Table 30).

If the user selects an unused map RAM entry (126 or 127) for an output shift-register position, then the corresponding output bit is always low (segment or grid OFF).

When selecting an invalid map RAM entry (for example, codes 48 to 83 to select annunciators in 96/2 mode, which does not support annunciators), the corresponding output bit is always low (segment or grid OFF).

If the map RAM entry corresponds to a nonexistent font segment (no action in Table 30) when the digit data is processed through the character font, then the result again is zero (segment or grid OFF).

The output map data is indirectly accessed by an autoincrementing output map address pointer in the MAX6852 at address 0x06. The output map address pointer can be written (i.e., set to an address between 0x00 and 0x79) but cannot be read back. The output map data is written and read back through the output map address pointer.

Table 31 shows how to set the output map address pointer to a value within the acceptable range. Bit D7 is set to denote that the user is writing the output map address pointer. If the user attempts to set the output map address to one of the out-of-range addresses by writing data in range 0xFA to 0xFF, then address 0x00 is set instead.

After the last data location 0xF9 has been written, further output map data entries are ignored until the output map address pointer is reset.

The output map data can be written to the address set by the output map address pointer. Bit D7 is clear to denote that the user is writing actual output map data. The output map address pointer is autoincremented after the output map data has been written to the current location. If the user writes the output map data in the RAM order, then the output map address pointer need only be set once, or even not at all as the address is set to 0x00 as power-up default (Table 32).

The output map data can be read by reading address 0x86. The 7-bit output map data at the address set by the output map address pointer is read back, with the MSB clear. The output map address pointer is auto-

cremented after the output map data has been read from the current location, in the same way as for a write (Table 33).

Filament Drive

The VFD filament is typically driven with an AC waveform, supplied by a center-tapped 50Hz or 60Hz power transformer as part of the system power supply. However, if the system has only DC supplies available, the filament must be powered by a DC-AC or DC-DC converter.

The MAX6852 can generate the waveforms on the PHASE1 and PHASE2 outputs to drive the VFD filament using a full bridge (push-pull drive). The PHASE1 and PHASE2 outputs can be used as general-purpose outputs if the filament drive is not required. The bridge drive transistors are external, but the waveforms are generated by the MAX6852.

The waveform generation uses PWM to set the effective RMS voltage across the filament, as a fraction of the external supply voltage (Figure 13) (Table 34). The filament switching frequency is synchronized to the multiplex scan clock, eliminating beating artifacts due to differing filament and multiplex frequencies.

The PWM duty cycle is controlled by the filament duty-cycle register (Table 35). The effective RMS voltage across the filament is given by the expression:

$$V_{RMS} = FilOn \times (V_{FIL} - V_{LO-BRIDGE} - V_{HI-BRIDGE}) / 200$$

or, rearranged:

$$Duty = 200 \times V_{RMS} / (V_{FIL} - V_{LO-BRIDGE} - V_{HI-BRIDGE})$$

where:

FilOn is the number to store in the filament duty-cycle register, address 0x09.

V_{FIL} is the supply voltage to the filament driver bridge (V).

V_{RMS} is the specified nominal filament supply voltage (V).

V_{LO-BRIDGE} is the voltage drop across a low-side bridge driver (V).

V_{HI-BRIDGE} is the voltage drop across a high-side bridge driver (V).

The minimum commutation time, shown at (C) in Figure 13, is set by (2/OSC)s (500ns when OSC = 4MHz) to ensure that shoot-through currents cannot flow during phase reversal. Otherwise, the duty cycle of the bridge (total on time: total time) sets the RMS voltage across the filament. This technique provides a low-cost AC filament supply when using a regulated supply higher than the RMS voltage rating of the filament.

4-Wire Interfaced, 5 × 7 Matrix Vacuum-Fluorescent Display Controller

MAX6852

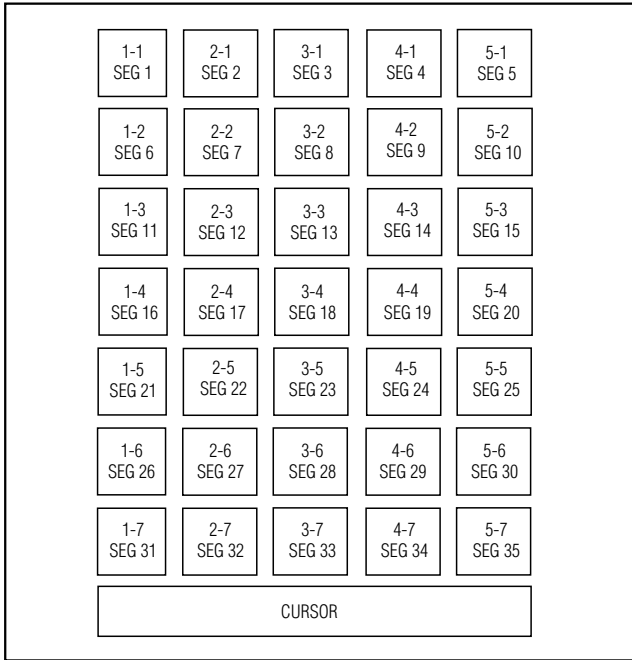

Figure 12. Relationship Between Segment Output and VFD Tube 5 × 7 Matrix Dots

Figure 14 shows the external components required for the filament driver using a FET bridge.

PHASE1 and PHASE2 Outputs

PHASE1 and PHASE2 can be individually programmed as one of four output types (Tables 36, 37).

When using the filament drive, first ensure that the filament duty-cycle register 0x09 is set to the correct value before configuring the PHASE1 and PHASE2 outputs to be filament drives. To stop the filament drive, program either PHASE1 or PHASE2 (or both) to be logic-low general-purpose outputs. Both PHASE1 and PHASE2 outputs come out of power-on-reset in logic-low condition.

PUMP Output

The PUMP output can be programmed as one of four output types (Table 38).

PORT0 and PORT1 Outputs

PORT0 and PORT1 can be individually programmed as one of eight output types (Tables 39, 40). The PORT1 choices are similar to the PORT0 choices, except that the last four items are invert logic. PORT0 output comes out of power-on-reset in logic-low condition, whereas PORT1 output initializes high.

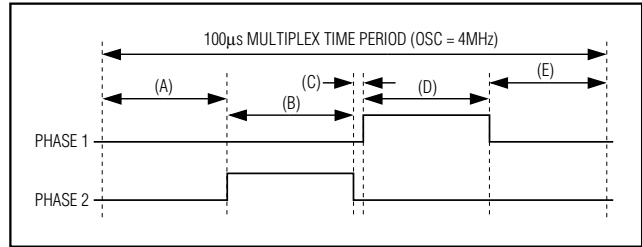

Figure 13. Filament Bridge Driver Timing Waveforms

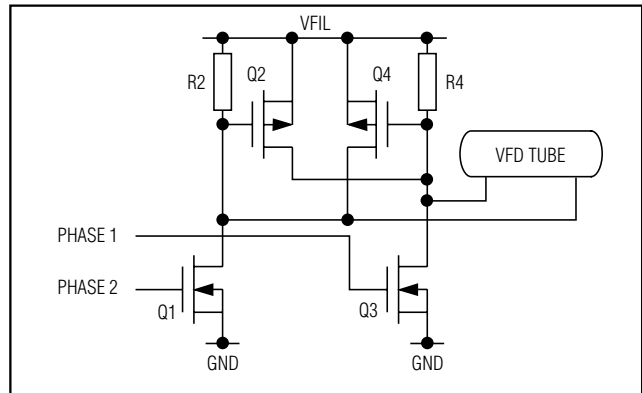

Figure 14. Filament Bridge Driver (MOSFET)

The PORT0 and PORT1 shutdown outputs allow external hardware (for example, a DC-DC converter power supply for VFD) to be disabled by the MAX6852 when the MAX6852 is shut down.

The 625Hz, 1250Hz, and 2500Hz outputs can drive a piezo sounder either from PORT0 or PORT1 alone, or by both ports together as bridge drive. For bridge drive, the sounder is connected between PORT0 and PORT1, taking advantage of the PORT1 output being inverted with respect to PORT0. Select different frequencies for PORT0 and PORT1 to obtain a wider range of sounds when bridge drive is used.

Multiplex Clock and Blink Timing

The OSC1 and OSC2 inputs set the multiplex and blink timing for the display driver. Connect an external resistor from OSC2 to GND and an external capacitor C_{OSC} from OSC1 to GND to set the frequency of the internal RC oscillator. Alternatively, overdrive OSC1 with an external TTL or CMOS clock. If an exact blink rate or multiplex period is required, use an external clock ranging between 2MHz and 8MHz to drive OSC1.

4-Wire Interfaced, 5 × 7 Matrix Vacuum-Fluorescent Display Controller

The multiplex clock frequency determines the multiplex scan rate and the blink timing. The display scan rate is $\{OSC / 400 / (1 + \text{grids register value})\}$. There are 400 OSC cycles per digit multiplex period. For example, with OSC = 4MHz, each display digit is enabled for 100 μ s. For a 40-grid display tube (grids register value = 39 or 0x27), the display scan rate is 250Hz.

The BLINK output is the selectable blink period clock. It is nominally 0.5Hz or 1Hz (OSC = 4MHz). It is low during the first half of the blink period, and high during the second half. The PORT0 and PORT1 general-purpose outputs may be programmed to be BLINK output. Synchronize the BLINK timing if desired by setting the T bit in the configuration register (Table 19).

The RC oscillator uses an external resistor R_{OSC} and an external capacitor C_{OSC} to set the oscillator frequency. R_{OSC} connects from OSC2 to ground. C_{OSC} connects from OSC1 to ground. The recommended values of R_{OSC} and C_{OSC} set the oscillator to 4MHz, which makes the BLINK frequencies 0.5Hz and 1 Hz:

$$f_{OSC} = K_F / (R_{OSC} \times [C_{OSC} + C_{STRAY}]) \text{ MHz}$$

where:

$$K_F = 2320$$

R_{OSC} = external resistor in k Ω (allowable range 8k Ω to 80k Ω)

C_{OSC} = external capacitor in pF

C_{STRAY} = stray capacitance from OSC1 to GND in pF, typically 2pF

For OSC = 4MHz, R_{OSC} is 10k Ω and C_{OSC} is 56pF.

The effective value of C_{OSC} includes not only the actual external capacitor used, but also the stray capacitance from OSC1 to GND. This capacitance is usually in the 1pF-to-5pF range, depending on the layout used.

The allowed range of f_{OSC} is 2MHz to 8MHz. If f_{OSC} is set too high, the internal oscillator can stop working. An internal fail-safe circuit monitors the multiplex clock and detects a slow or nonworking multiplex clock. When a slow or nonworking multiplex clock is detected, an internal fail-safe oscillator generates a replacement clock of about 200kHz. This backup clock ensures that the VFD is not damaged by the multiplex operation halting inadvertently. The scan rate for 16 digits is about 15Hz in fail-safe mode, and the display flickers. A flickering display is a good indication that there is a problem with the multiplex clock.

Power Supplies

The MAX6852 operates from a single 2.7V to 3.6V power supply. Bypass the power supply to GND with a 0.1 μ F capacitor as close to the device as possible. Add a bulk capacitor (such as a low-cost electrolytic 1 μ F to 22 μ F) if the MAX6852 is driving high current from any of the general-purpose output ports.

Table 8. Memory Mapping of User-Defined Font Register 0x05

COMMAND ADDRESS	REGISTER DATA	READ OR WRITE	FUNCTION
0x85	0x00–0x7F	Read	Read 7-bit user-definable font data entry from current font address. MSB of the register data is clear. Font address pointer is incremented after the read.
0x05	0x00–0x7F	Write	Write 7-bit user-definable font data entry to current font address. Font address pointer is incremented after the write.
0x05	0x80–0xFF	Write	Write font address pointer with the register data.

Table 9. Font Pointer Address Behavior

FONT POINTER ADDRESS	ACTION
0x80 to 0xF6	Valid range to set the font address pointer. Pointer autoincrements after a font data read or write, while pointer address remains in this range.
0xF7	Further font data is ignored after a font data read or write to this pointer address.
0xF8 to 0xFF	Invalid range to set the font address pointer. Pointer is set to 0x80.

4-Wire Interfaced, 5 × 7 Matrix Vacuum-Fluorescent Display Controller

MAX6852

Table 10. User-Definable Font Pointer Base Address

FONT CHARACTER	COMMAND ADDRESS	REGISTER DATA	REGISTER DATA							
			D7	D6	D5	D4	D3	D2	D1	D0
RAM00	0x05	0x80	1	0	0	0	0	0	0	0
RAM01	0x05	0x85	1	0	0	0	0	1	0	1
RAM02	0x05	0x8A	1	0	0	0	1	0	1	0
RAM03	0x05	0x8F	1	0	0	0	1	1	1	1
RAM04	0x05	0x94	1	0	0	1	0	1	0	0
RAM05	0x05	0x99	1	0	0	1	1	0	0	1
RAM06	0x05	0x9E	1	0	0	1	1	1	1	0
RAM07	0x05	0xA3	1	0	1	0	0	0	1	1
RAM08	0x05	0xA8	1	0	1	0	1	0	0	0
RAM09	0x05	0xAD	1	0	1	0	1	1	0	1
RAM10	0x05	0xB2	1	0	1	1	0	0	1	0
RAM11	0x05	0xB7	1	0	1	1	0	1	1	1
RAM12	0x05	0xBC	1	0	1	1	1	1	0	0
RAM13	0x05	0xC1	1	1	0	0	0	0	0	1
RAM14	0x05	0xC6	1	1	0	0	0	1	1	0
RAM15	0x05	0xCB	1	1	0	0	1	0	1	1
RAM16	0x05	0xD0	1	1	0	1	0	0	0	0
RAM17	0x05	0xD5	1	1	0	1	0	1	0	1
RAM18	0x05	0xDA	1	1	0	1	1	0	1	0
RAM19	0x05	0xDF	1	1	0	1	1	1	1	1
RAM20	0x05	0xE4	1	1	1	0	0	1	0	0
RAM21	0x05	0xE9	1	1	1	0	1	0	0	1
RAM22	0x05	0xEE	1	1	1	0	1	1	1	0
RAM23	0x05	0xF3	1	1	1	1	0	0	1	1

4-Wire Interfaced, 5 × 7 Matrix Vacuum-Fluorescent Display Controller

Table 11. User-Definable Character Storage Example

FONT CHARACTER	FONT ADDRESS POINTER	COMMAND ADDRESS	REGISTER DATA							
			D7	D6	D5	D4	D3	D2	D1	D0
RAM00	0x00	0x05	0	0	1	1	1	1	1	0
RAM00	0x01	0x05	0	1	0	1	0	0	0	1
RAM00	0x02	0x05	0	1	0	0	1	0	0	1
RAM00	0x03	0x05	0	1	0	0	0	1	0	1
RAM00	0x04	0x05	0	0	1	1	1	1	1	0
RAM01	0x05	0x05	0	0	0	0	0	0	0	0
RAM01	0x06	0x05	0	1	0	0	0	0	1	0
RAM01	0x07	0x05	0	1	1	1	1	1	1	1
RAM01	0x08	0x05	0	1	0	0	0	0	0	0
RAM01	0x09	0x05	0	0	0	0	0	0	0	0
RAM02	0x0A	0x05	0	1	0	0	0	0	1	0
RAM02	0x0B	0x05	0	1	1	0	0	0	0	1
RAM02	0x0C	0x05	0	1	0	1	0	0	0	1
RAM02	0x0D	0x05	0	1	0	0	1	0	0	1
RAM02	0x0E	0x05	0	1	0	0	0	1	1	0

Table 12. Setting a Font Character to RAM Example

COMMAND ADDRESS	REGISTER DATA	ACTION BEING PERFORMED
0x05	0x8A	Set font address pointer to the base address of font character RAM02.
0x05	0x42	1st 7 bits of data: 100010 goes to font address 0x8A; pointer then autoincrements to address 0x8B.
0x05	0x61	2nd 7 bits of data: 1100001 goes to font address 0x8B; pointer then autoincrements to address 0x8C.
0x05	0x51	3rd 7 bits of data: 1010001 goes to font address 0x8C; pointer then autoincrements to address 0x8D.
0x05	0x49	4th 7 bits of data: 1001001 goes to font address 0x8D; pointer then autoincrements to address 0x8E.
0x05	0x46	5th 7 bits of data: 1000110 goes to font address 0x8E; pointer then autoincrements to address 0x8F.

Table 13. Cursor Register Format

MODE	COMMAND ADDRESS	REGISTER DATA								
		D7	D6	D5	D4	D3	D2	D1	D0	
Cursor register.	0x0F	BLINK	CURSOR POSITION							
Digit 1's cursor is lit continuously.	0x0F	0	0	0	0	0	0	0	0	
Digit 1's cursor is lit only for the first half of each blink period.	0x0F	1	0	0	0	0	0	0	0	
UP TO	0x0F	UP TO								
Digit 96's cursor is lit continuously.	0x0F	0	1	0	1	1	1	1	1	
Digit 96's cursor is lit only for the first half of each blink period.	0x0F	1	1	0	1	1	1	1	1	
No cursor is lit.	0x0F	X	1	1	X	X	X	X	X	

4-Wire Interfaced, 5 × 7 Matrix Vacuum-Fluorescent Display Controller

MAX6852

Table 14. Annunciator Registers Format

ANNUNCIATOR BYTE	REGISTER DATA							
	D7	D6	D5	D4	D3	D2	D1	D0
BIT ALLOCATIONS	ANNUNCIATOR A4		ANNUNCIATOR A3		ANNUNCIATOR A2		ANNUNCIATOR A1	
Annunciator A1 is off.	X	X	X	X	X	X	0	0
Annunciator A1 is lit only for the first half of each blink period.	X	X	X	X	X	X	0	1
Annunciator A1 is lit only for the second half of each blink period.	X	X	X	X	X	X	1	0
Annunciator A1 is lit continuously.	X	X	X	X	X	X	1	1
Annunciator A2 is off.	X	X	X	X	0	0	X	X
Annunciator A2 is lit only for the first half of each blink period.	X	X	X	X	0	1	X	X
Annunciator A2 is lit only for the second half of each blink period.	X	X	X	X	1	0	X	X
Annunciator A2 is lit continuously.	X	X	X	X	1	1	X	X
Annunciator A3 is off.	X	X	0	0	X	X	X	X
Annunciator A3 is lit only for the first half of each blink period.	X	X	0	1	X	X	X	X
Annunciator A3 is lit only for the second half of each blink period.	X	X	1	0	X	X	X	X
Annunciator A3 is lit continuously.	X	X	1	1	X	X	X	X
Annunciator A4 is off.	0	0	X	X	X	X	X	X
Annunciator A4 is lit only for the first half of each blink period.	0	1	X	X	X	X	X	X
Annunciator A4 is lit only for the second half of each blink period.	1	0	X	X	X	X	X	X
Annunciator A4 is lit continuously.	1	1	X	X	X	X	X	X

Table 15. Configuration Register Format

MODE	REGISTER DATA							
	D7	D6	D5	D4	D3	D2	D1	D0
Configuration register	P	M	R	T	X	B	L	S

Table 16. Shutdown Control (S Data Bit D0) Format

MODE	REGISTER DATA							
	D7	D6	D5	D4	D3	D2	D1	D0
Shutdown	P	M	R	T	X	B	L	0
Normal operation	P	M	R	T	X	B	L	1

Table 17. Configuration Lock (L Data Bit D1) Format

MODE	REGISTER DATA							
	D7	D6	D5	D4	D3	D2	D1	D0
Unlocked	P	M	R	T	X	B	0	S
Locked	P	M	R	T	X	B	1	S

4-Wire Interfaced, 5 × 7 Matrix Vacuum-Fluorescent Display Controller

Table 18. Blink Rate Selection (B Data Bit D2) Format

MODE	REGISTER DATA							
	D7	D6	D5	D4	D3	D2	D1	D0
Slow blinking (cursor and annunciators blink on for 1s, off for 1s, for OSC = 4MHz)	P	M	R	T	X	0	L	S
Fast blinking (cursor and annunciators blink on for 0.5s, off for 0.5s, for OSC = 4MHz)	P	M	R	T	X	1	L	S

Table 19. Global Blink Timing Synchronization (T Data Bit D4) Format

MODE	REGISTER DATA							
	D7	D6	D5	D4	D3	D2	D1	D0
Blink timing counters are unaffected.	P	M	R	0	X	B	L	S
Blink timing counters are cleared on the rising edge of \overline{CS} .	P	M	R	1	X	B	L	S

Table 20. Global Clear Digit Data (R Data Bit D5) Format

MODE	REGISTER DATA							
	D7	D6	D5	D4	D3	D2	D1	D0
Segment and annunciator data are unaffected.	P	M	0	T	X	B	L	S
Segment and annunciator data (address range 0x20 to 0x7F) are cleared on the rising edge of \overline{CS} .	P	M	1	T	X	B	L	S

Table 21. Display Mode (M Data Bit D6) Format

MODE	DISPLAY TYPE	REGISTER DATA							
		D7	D6	D5	D4	D3	D2	D1	D0
48/1	Up to 48 digits, 1 digit per grid	P	0	R	T	X	B	L	S
96/2	Up to 96 digits, 2 digits per grid	P	1	R	T	X	B	L	S

Table 22. Blink Phase Readback (P Data Bit D7) Format

MODE	REGISTER DATA							
	D7	D6	D5	D4	D3	D2	D1	D0
P1 blink phase	0	M	R	T	X	B	L	S
P0 blink phase	1	M	R	T	X	B	L	S

Table 23. Serial-Data Format (16 Bits)

D15	D14	D13	D12	D11	D10	D9	D8	D7	D6	D5	D4	D3	D2	D1	D0	
R/W	COMMAND ADDRESS							MSB	REGISTER DATA							LSB

4-Wire Interfaced, 5 × 7 Matrix Vacuum-Fluorescent Display Controller

MAX6852

Table 24. Grids Register Format

GRIDS	COMMAND ADDRESS	REGISTER DATA								HEX CODE
		D7	D6	D5	D4	D3	D2	D1	D0	
Display has 1 grid: G0	0x03	0	0	0	0	0	0	0	0	0x00
Display has 2 grids: G0 and G1	0x03	0	0	0	0	0	0	0	1	0x01
Display has 3 grids: G0 to G2	0x03	0	0	0	0	0	0	1	0	0x02
Display has 4 grids: G0 to G3	0x03	0	0	0	0	0	0	1	1	0x03
UP TO	0x03	0	0	—	—	—	—	—	—	—
Display has 45 grids: G0 to G44	0x03	0	0	1	0	1	1	0	0	0x2C
Display has 46 grids: G0 to G45	0x03	0	0	1	0	1	1	0	1	0x2D
Display has 47 grids: G0 to G46	0x03	0	0	1	0	1	1	1	0	0x2E
Display has 48 grids: G0 to G47	0x03	0	0	1	0	1	1	1	1	0x2F

Table 25. Intensity Register Format

DUTY CYCLE	VFBLANK BEHAVIOR (OSC = 4MHz)	COMMAND ADDRESS	REGISTER DATA								HEX CODE
			D7	D6	D5	D4	D3	D2	D1	D0	
1/16 (min on)	High for 6.25µs, low for 6.25µs, high for 87.5µs	0x02	X	X	X	X	0	0	0	0	0xX0
2/16	High for 6.25µs, low for 12.5µs, high for 81.25µs	0x02	X	X	X	X	0	0	0	1	0xX1
3/16	High for 6.25µs, low for 18.75µs, high for 75µs	0x02	X	X	X	X	0	0	1	0	0xX2
4/16	High for 6.25µs, low for 25µs, high for 68.75µs	0x02	X	X	X	X	0	0	1	1	0xX3
5/16	High for 6.25µs, low for 31.25µs, high for 62.5µs	0x02	X	X	X	X	0	1	0	0	0xX4
6/16	High for 6.25µs, low for 37.5µs, high for 56.25µs	0x02	X	X	X	X	0	1	0	1	0xX5
7/16	High for 6.25µs, low for 43.75µs, high for 50µs	0x02	X	X	X	X	0	1	1	0	0xX6
8/16	High for 6.25µs, low for 50µs, high for 43.75µs	0x02	X	X	X	X	0	1	1	1	0xX7
9/16	High for 6.25µs, low for 56.25µs, high for 37.5µs	0x02	X	X	X	X	1	0	0	0	0xX8
10/16	High for 6.25µs, low for 62.5µs, high for 31.25µs	0x02	X	X	X	X	1	0	0	1	0xX9
11/16	High for 6.25µs, low for 68.75µs, high for 25µs	0x02	X	X	X	X	1	0	1	0	0xXA
12/16	High for 6.25µs, low for 75µs, high for 18.75µs	0x02	X	X	X	X	1	0	1	1	0xXB
13/16	High for 6.25µs, low for 81.25µs, high for 12.5µs	0x02	X	X	X	X	1	1	0	0	0xXC
14/16	High for 6.25µs, low for 87.5µs, high for 6.25µs	0x02	X	X	X	X	1	1	0	1	0xXD
15/16	High for 6.25µs, low for 93.75µs	0x02	X	X	X	X	1	1	1	0	0xXE
15/16 (max on)	High for 6.25µs, low for 93.75µs	0x02	X	X	X	X	1	1	1	1	0xFF

4-Wire Interfaced, 5 × 7 Matrix Vacuum-Fluorescent Display Controller

Table 26. VFBLANK Polarity Register Format

GRIDS	COMMAND ADDRESS	REGISTER DATA								HEX CODE	
		D7	D6	D5	D4	D3	D2	D1	D0		
VFBLANK is high to disable the display.	0x01	X	X	X	X	X	X	X	0	0	0xX0
VFBLANK is low to disable the display.	0x01	X	X	X	X	X	X	X	1	0	0xX2

Table 27. Display-Test and Device ID Register Format

MODE	COMMAND ADDRESS	REGISTER DATA								
		D7	D6	D5	D4	D3	D2	D1	D0	
Normal operation	0x07	X	X	X	X	X	X	X	X	0
Display test	0x07	X	X	X	X	X	X	X	X	1
Read MAX6852 device ID and display test status	0x87	0	0	0	0	0	0	1	1	DT

Table 28. Shift-Limit Register Format

SHIFT LIMIT	COMMAND ADDRESS	REGISTER DATA								HEX CODE	
		D7	D6	D5	D4	D3	D2	D1	D0		
Minimum setting example (01)	0x0E	0	0	0	0	0	0	0	0	1	0x01
Maximum setting example (121 or 0x79)	0x0E	0	1	1	1	1	0	0	0	1	0x79

4-Wire Interfaced, 5 × 7 Matrix Vacuum-Fluorescent Display Controller

MAX6852

Table 29. Output Map RAM Codes

OUTPUT MAP RAM CODE (DECIMAL)	APPLICATION	FUNCTION MAPPED BY OUTPUT MAP RAM CODE
0 to 47	48 grids	Grids G0 to G47
48, 49, 50, 51, 52	5 x 7 matrix character segments Digits 0 to 47 only Use character registers 0x20 to 0x4F (Figure 12)	5 x 7 matrix character segments 1-1, 2-1, 3-1, 4-1, 5-1
53, 54, 55, 56, 57		5 x 7 matrix character segments 1-2, 2-2, 3-2, 4-2, 5-2
58, 59, 60, 61, 62		5 x 7 matrix character segments 1-3, 2-3, 3-3, 4-3, 5-3
63, 64, 65, 66, 67		5 x 7 matrix character segments 1-4, 2-4, 3-4, 4-4, 5-4
68, 69, 70, 71, 72		5 x 7 matrix character segments 1-5, 2-5, 3-5, 4-5, 5-5
73, 74, 75, 76, 77		5 x 7 matrix character segments 1-6, 2-6, 3-6, 4-6, 5-6
78, 79, 80, 81, 82		5 x 7 matrix character segments 1-7, 2-7, 3-7, 4-7, 5-7
83		5 x 7 matrix character segment DP
84, 85, 86, 87, 88	5 x 7 matrix character segments Digits 48 to 95 only Use character registers 0x50 to 0x7F (Figure 12) Only valid for 96/2 mode (display mode select bit M = 1)	5 x 7 matrix character segments 1-1, 2-1, 3-1, 4-1, 5-1
89, 90, 91, 92, 93	—	5 x 7 matrix character segments 1-2, 2-2, 3-2, 4-2, 5-2
94, 95, 96, 97, 98	—	5 x 7 matrix character segments 1-3, 2-3, 3-3, 4-3, 5-3
99, 100, 101, 102, 103		5 x 7 matrix character segments 1-4, 2-4, 3-4, 4-4, 5-4
104, 105, 106, 107, 108		5 x 7 matrix character segments 1-5, 2-5, 3-5, 4-5, 5-5
109, 110, 111, 112, 113		5 x 7 matrix character segments 1-6, 2-6, 3-6, 4-6, 5-6
114, 115, 116, 117, 118		5 x 7 matrix character segments 1-7, 2-7, 3-7, 4-7, 5-7
119		—
120 to 123	4 annunciators Only valid for 48/1 mode (display mode select bit M = 0)	Annunciator A1 to annunciator A4
124	Cursor	Cursor segment for digits 0 to 47 only
125	Cursor Only valid for 96/2 mode (display mode select bit M = 1)	Cursor segment for digits 48 to 95 only
126, 127	Unused	No action

4-Wire Interfaced, 5 × 7 Matrix Vacuum-Fluorescent Display Controller

Table 30. Output Map RAM Initial Power-Up Status

OUTPUT MAP RAM ADDRESS	OUTPUT MAP RAM CODE ON POWER-UP (DECIMAL)	FUNCTION MAPPED BY OUTPUT MAP RAM CODE
0x00 to 0x27	0–39	Grids 0–39
0x28, 0x29, 0x2A, 0x2B, 0x2C	48, 49, 50, 51, 52	5 x 7 matrix character segments 1-1, 2-1, 3-1, 4-1, 5-1
0x2D, 0x2E, 0x2F, 0x30, 0x31	53, 54, 55, 56, 57	5 x 7 matrix character segments 1-2, 2-2, 3-2, 4-2, 5-2
0x32, 0x33, 0x34, 0x35, 0x36	58, 59, 60, 61, 62	5 x 7 matrix character segments 1-3, 2-3, 3-3, 4-3, 5-3
0x37, 0x38, 0x39, 0x3A, 0x3B	63, 64, 65, 66, 67	5 x 7 matrix character segments 1-4, 2-4, 3-4, 4-4, 5-4
0x3C, 0x3D, 0x3E, 0x3F, 0x40	68, 69, 70, 71, 72	5 x 7 matrix character segments 1-5, 2-5, 3-5, 4-5, 5-5
0x41, 0x42, 0x43, 0x44, 0x45	73, 74, 75, 76, 77	5 x 7 matrix character segments 1-6, 2-6, 3-6, 4-6, 5-6
0x46, 0x47, 0x48, 0x49, 0x4A	78, 79, 80, 81, 82	5 x 7 matrix character segments 1-7, 2-7, 3-7, 4-7, 5-7
0x4B	83	5 x 7 matrix character segment DP
0x4C, 0x4D, 0x4E, 0x4F, 0x50	84, 85, 86, 87, 88	5 x 7 matrix character segments 1-1, 2-1, 3-1, 4-1, 5-1
0x51, 0x52, 0x53, 0x54, 0x55	89, 90, 91, 92, 93	5 x 7 matrix character segments 1-2, 2-2, 3-2, 4-2, 5-2
0x56, 0x57, 0x58, 0x59, 0x5A	94, 95, 96, 97, 98	5 x 7 matrix character segments 1-3, 2-3, 3-3, 4-3, 5-3
0x5B, 0x5C, 0x5D, 0x5E, 0x5F	99, 100, 101, 102, 103	5 x 7 matrix character segments 1-4, 2-4, 3-4, 4-4, 5-4
0x60, 0x61, 0x62, 0x63, 0x64	104, 105, 106, 107, 108	5 x 7 matrix character segments 1-5, 2-5, 3-5, 4-5, 5-5
0x65, 0x66, 0x67, 0x68, 0x69	109, 110, 111, 112, 113	5 x 7 matrix character segments 1-6, 2-6, 3-6, 4-6, 5-6
0x6A, 0x6B, 0x6C, 0x6D, 0x6E	114, 115, 116, 117, 118	5 x 7 matrix character segments 1-7, 2-7, 3-7, 4-7, 5-7
0x6F	119	5 x 7 matrix character segment DP
0x70	124	Cursor segment for digits 0 to 47 1st row
0x71	125	Cursor segment for digits 0 to 47 2nd row
0x72 to 0x79	127	No action

Table 31. Setting Output Map Address Pointer

MODE	COMMAND ADDRESS	REGISTER DATA							
		D7	D6	D5	D4	D3	D2	D1	D0
Set output map address to minimum (0x00) with data 0x80. (Note that this address is set as a power-up default.)	0x06	1	0	0	0	0	0	0	0
Set output map address to maximum 0x79 with data 0xF9.	0x06	1	1	1	1	1	0	0	1

Table 32. Writing Output Map Data

MODE	COMMAND ADDRESS	REGISTER DATA							
		D7	D6	D5	D4	D3	D2	D1	D0
Write output map data; output map address pointer is autoincremented after the output map data has been written to the current location.	0x06	0	7 bits of output map data						

4-Wire Interfaced, 5 × 7 Matrix Vacuum-Fluorescent Display Controller

Table 33. Reading Output Map Data

MODE	COMMAND ADDRESS	REGISTER DATA								
		D7	D6	D5	D4	D3	D2	D1	D0	
Read output map data; output map address pointer is autoincremented after the output map data has been read from the current location.	0x86	0	7 bits of output map data							

Table 34. Filament Bridge Driver Timing

TIMING POINT	PHASE1 BEHAVIOR	PHASE2 BEHAVIOR	EXAMPLE 1 DUTY = 1 (MIN)	EXAMPLE 2 DUTY = 100	EXAMPLE 3 DUTY = 198
(A)	Low for (199 - FilOn) cycles	Low for (199 - FilOn) cycles	198	99	1
(B)	Low for (FilOn) cycles	High for (FilOn) cycles	1	100	198
(C)	Low for (2) cycles	Low for (2) cycles	2	2	2
(D)	High for (FilOn) cycles	Low for (FilOn) cycles	1	100	198
(E)	Low for (199 - FilOn) cycles	Low for (199 - FilOn) cycles	198	99	1
Total 4MHz cycles (OSC = 4MHz)	400 cycles = 100µs	400 cycles = 100µs	400 cycles = 100µs	400 cycles = 100µs	400 cycles = 100µs

Table 35. Filament Duty-Cycle Register Format

FILAMENT DUTY CYCLE	COMMAND ADDRESS	REGISTER DATA								HEX CODE
		D7	D6	D5	D4	D3	D2	D1	D0	
Minimum setting example (01)	0x09	0	0	0	0	0	0	0	1	0x01
Maximum setting example (199 or 0xC7)	0x09	1	1	0	0	0	1	1	1	0xC7

Table 36. PHASE1 Register Format

PHASE1 BEHAVIOR	COMMAND ADDRESS	REGISTER DATA								HEX CODE
		D7	D6	D5	D4	D3	D2	D1	D0	
General-purpose output, logic 0. This is the power-up condition.	0x0A	X	X	X	X	X	X	0	0	0xX0
General-purpose output, logic 1.	0x0A	X	X	X	X	X	X	0	1	0xX1
Output gives blink status: 0 if blink phase P0; 1 if blink phase P1.	0x0A	X	X	X	X	X	X	1	0	0xX2
Filament drive PHASE1 (logic 0 during shutdown).	0x0A	X	X	X	X	X	X	1	1	0xX3

4-Wire Interfaced, 5 × 7 Matrix Vacuum-Fluorescent Display Controller

Table 37. PHASE2 Register Format

PHASE2 BEHAVIOR	COMMAND ADDRESS	REGISTER DATA								HEX CODE
		D7	D6	D5	D4	D3	D2	D1	D0	
General-purpose output, logic 0. This is the power-up condition.	0x0B	X	X	X	X	X	X	0	0	0xX0
General-purpose output, logic 1.	0x0B	X	X	X	X	X	X	0	1	0xX1
Output gives blink status: 0 if blink phase P0; 1 if blink phase P1.	0x0B	X	X	X	X	X	X	1	0	0xX2
Filament drive PHASE2 (logic 0 during shutdown).	0x0B	X	X	X	X	X	X	1	1	0xX3

Table 38. PUMP Register Format

PUMP PORT BEHAVIOR	COMMAND ADDRESS	REGISTER DATA								HEX CODE
		D7	D6	D5	D4	D3	D2	D1	D0	
General-purpose output, logic 0. This is the power-up condition.	0x08	X	X	X	X	X	X	0	0	0xX0
General-purpose output, logic 1.	0x08	X	X	X	X	X	X	0	1	0xX1
80kHz square-wave output (OSC = 4MHz) (logic 0 during shutdown).	0x08	X	X	X	X	X	X	1	0	0xX2
DOUT output.	0x08	X	X	X	X	X	X	1	1	0xX3

Table 39. PORT0 Register Format

PORT0 PORT BEHAVIOR	COMMAND ADDRESS	REGISTER DATA								HEX CODE
		D7	D6	D5	D4	D3	D2	D1	D0	
General-purpose output, logic 0. This is the power-up condition.	0x0C	X	X	X	X	X	0	0	0	0xX0
General-purpose output, logic 1.	0x0C	X	X	X	X	X	0	0	1	0xX1
Output gives blink status: 0 if blink phase P0; 1 if blink phase P1.	0x0C	X	X	X	X	X	0	1	0	0xX2
DOUT output.	0x0C	X	X	X	X	X	0	1	1	0xX3
625Hz square-wave output zero in shutdown.	0x0C	X	X	X	X	X	1	0	0	0xX4
1250Hz square-wave output zero in shutdown.	0x0C	X	X	X	X	X	1	0	1	0xX5
2500Hz square-wave output zero in shutdown.	0x0C	X	X	X	X	X	1	1	0	0xX6
Output gives shutdown status: 0 if shutdown mode; 1 if operating mode.	0x0C	X	X	X	X	X	1	1	1	0xX7

4-Wire Interfaced, 5 × 7 Matrix Vacuum-Fluorescent Display Controller

Table 40. PORT1 Register Format

PORT1 PORT BEHAVIOR	COMMAND ADDRESS	REGISTER DATA								HEX CODE
		D7	D6	D5	D4	D3	D2	D1	D0	
General-purpose output, logic 0.	0x0D	X	X	X	X	X	0	0	0	0xX0
General-purpose output, logic 1. This is the power-up condition.	0x0D	X	X	X	X	X	0	0	1	0xX1
Output gives blink status: 0 if blink phase P0; 1 if blink phase P1.	0x0D	X	X	X	X	X	0	1	0	0xX2
DOUT output.	0x0D	X	X	X	X	X	0	1	1	0xX3
Inverted 625Hz square-wave output 1 in shutdown.	0x0D	X	X	X	X	X	1	0	0	0xX4
Inverted 1250Hz square-wave output 1 in shutdown.	0x0D	X	X	X	X	X	1	0	1	0xX5
Inverted 2500Hz square-wave output 1 in shutdown.	0x0D	X	X	X	X	X	1	1	0	0xX6
Output gives inverted shutdown status: 1 if shutdown mode; 0 if operating mode.	0x0D	X	X	X	X	X	1	1	1	0xX7

Functional Diagram

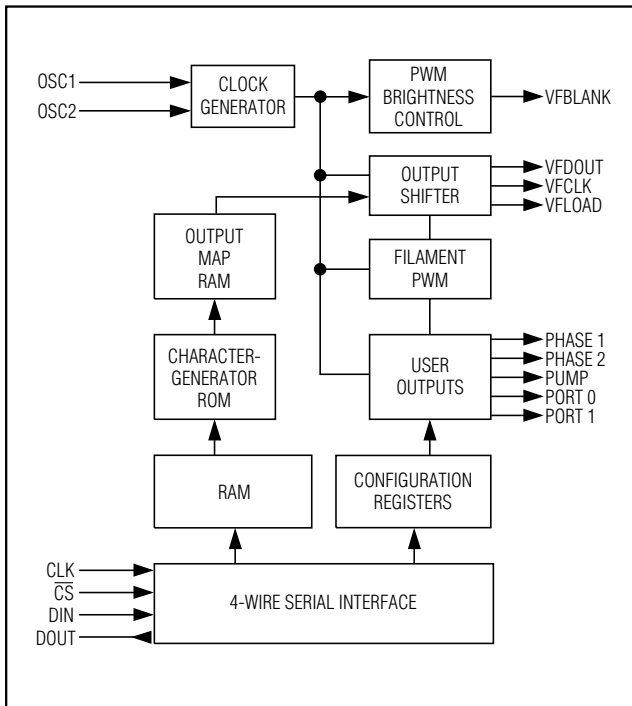

Pin Configuration

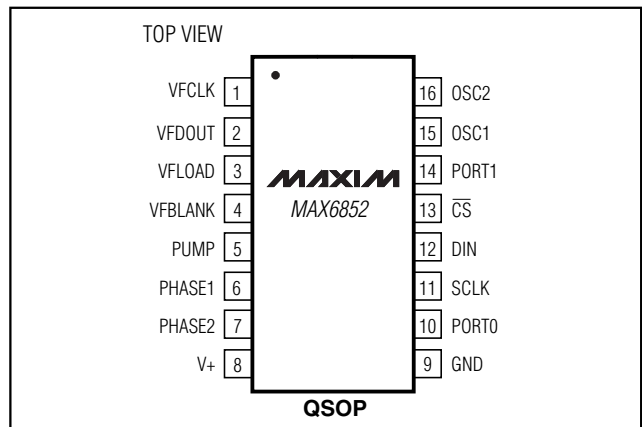

Chip Information

TRANSISTOR COUNT: 197,738
PROCESS: CMOS

4-Wire Interfaced, 5 × 7 Matrix Vacuum-Fluorescent Display Controller

Package Information

(The package drawing(s) in this data sheet may not reflect the most current specifications. For the latest package outline information, go to www.maxim-ic.com/packages.)

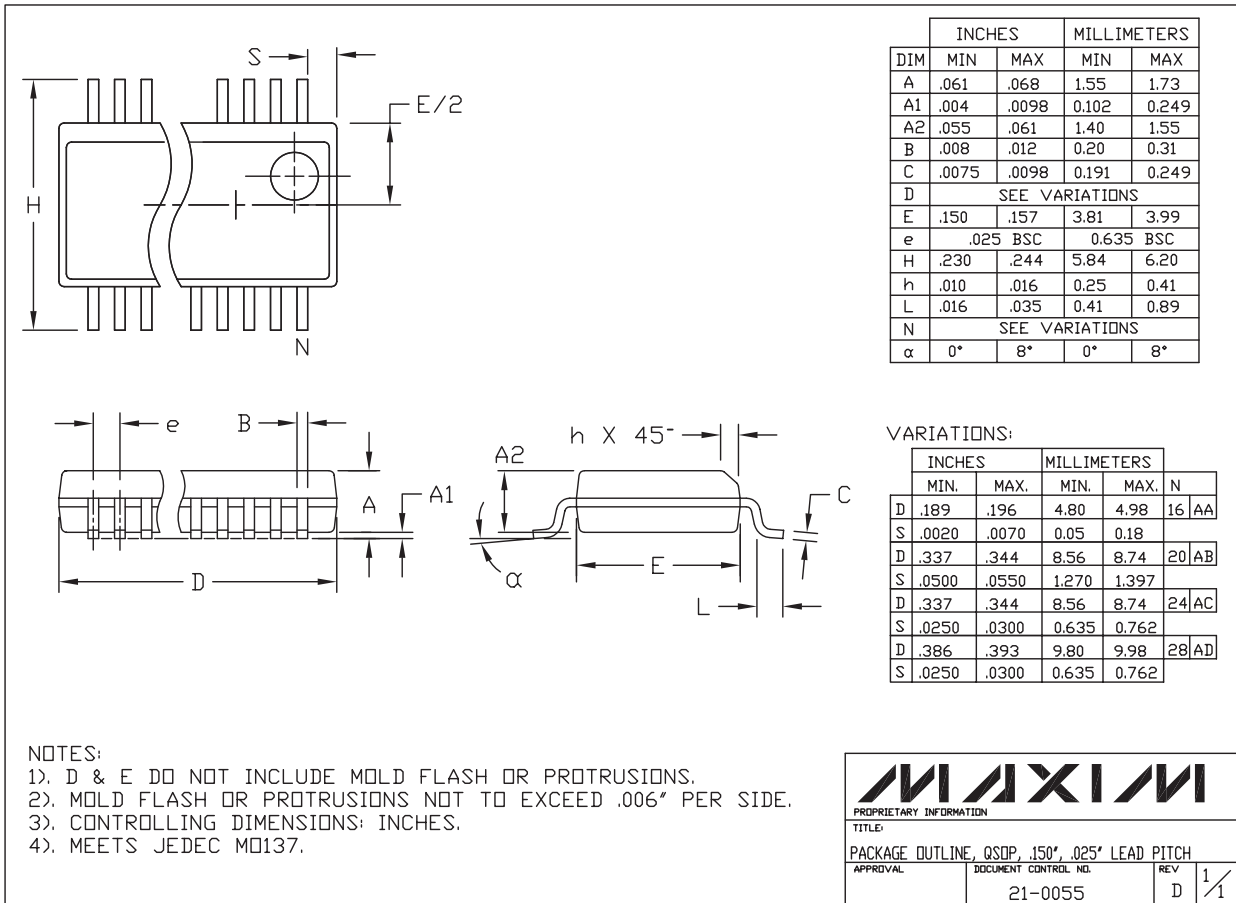

MAXIM

PROPRIETARY INFORMATION

TITLE:
 PACKAGE OUTLINE, QSQP, .150", .025" LEAD PITCH

APPROVAL	DOCUMENT CONTROL NO.	REV	
	21-0055	D	1/1

Maxim cannot assume responsibility for use of any circuitry other than circuitry entirely embodied in a Maxim product. No circuit patent licenses are implied. Maxim reserves the right to change the circuitry and specifications without notice at any time.