



Micropower, Ultra-Small, Single/Dual/Quad, Single-Supply Comparators

General Description

The MAX9021/MAX9022/MAX9024 single/dual/quad comparators are optimized for low-power consumption while still providing a fast output response. They are designed for single-supply applications from 2.5V to 5.5V, but can also operate from dual supplies. These comparators have a 3μs propagation delay and consume 2.8μA of supply current per comparator over the -40°C to +125°C operating temperature range. The combination of low-power, single-supply operation down to 2.5V, and ultra-small footprint makes these devices ideal for portable applications.

The MAX9021/MAX9022/MAX9024 have 4mV of built-in hysteresis to provide noise immunity and prevent oscillations even with a slow-moving input signal. The input common-mode range extends from the negative supply to within 1.1V of the positive supply. The design of the comparator-output stage substantially reduces switching current during output transitions, eliminating power-supply glitches.

The MAX9021 single comparator is available in tiny 5-pin SC70 and SOT23 packages. The MAX9022 dual comparator is available in 8-pin SOT23, μMAX, and SO packages, and the MAX9024 quad comparator is available in 14-pin TSSOP and SO packages.

Applications

Battery-Powered Portable Systems	Digital Line Receivers
Mobile Communications	Keyless Entry Systems
Sensor-Signal Detection	Threshold Detectors/ Discriminators
Photodiode Preamps	

Features

- ◆ Low-Cost Solution Available in Space-Saving SC70 Packages (Half the Size of SOT23)
- ◆ Low 2.8μA Supply Current
- ◆ 3μs Propagation Delay
- ◆ Internal 4mV Comparator Hysteresis
- ◆ Comparator Output Swings Rail-to-Rail®
- ◆ 2.5 to 5.5V Single-Supply Voltage Range
- ◆ No Phase Reversal for Overdriven Inputs
- ◆ Space-Saving Packages
 - 5-Pin SC70 (MAX9021)
 - 8-Pin SOT23 (MAX9022)
 - 8-Pin μMAX (MAX9022)
 - 14-Pin TSSOP (MAX9024)

Ordering Information

PART	TEMP RANGE	PIN-PACKAGE
MAX9021AXK-T	-40°C to +125°C	5 SC70-5
MAX9021AUK-T	-40°C to +125°C	5 SOT23-5
MAX9022AKA-T	-40°C to +125°C	8 SOT23-8
MAX9022AUA	-40°C to +125°C	8 μMAX
MAX9022ASA	-40°C to +125°C	8 SO
MAX9024AUD	-40°C to +125°C	14 TSSOP
MAX9024ASD	-40°C to +125°C	14 SO

Typical Application Circuit appears at end of data sheet.

Pin Configurations

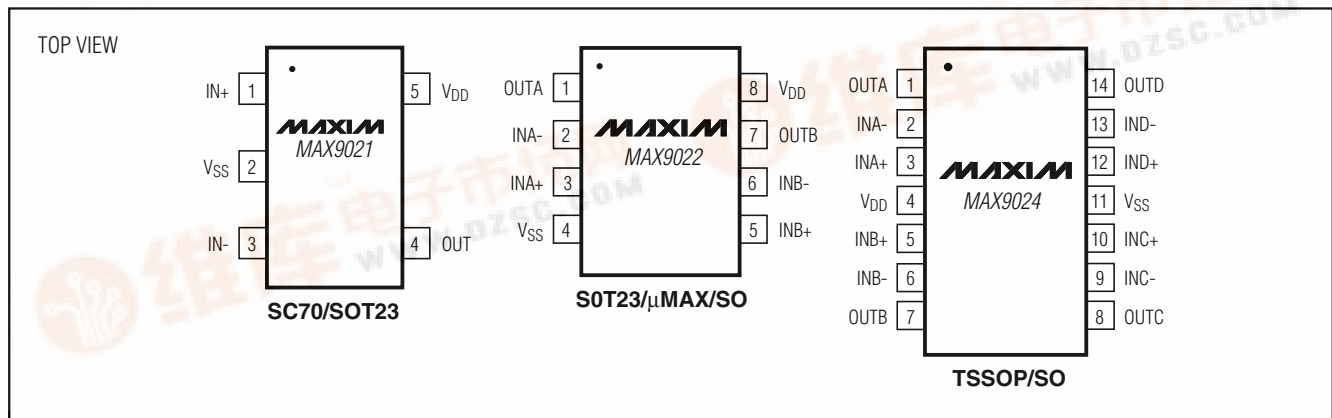

MAX9021/MAX9022/MAX9024

Rail-to-Rail is a registered trademark of Nippon Motorola, Ltd.

Micropower, Ultra-Small, Single/Dual/Quad, Single-Supply Comparators

ABSOLUTE MAXIMUM RATINGS

Supply Voltage (V_{DD} to V_{SS})	-0.3V to +6V	8-Pin μ MAX (derate 4.5mW/°C above +70°C)	362mW
Voltage Inputs ($IN+$, $IN-$ to V_{SS})	-0.3V to (V_{DD} + 0.3V)	8-Pin SO (derate 5.88mW/°C above +70°C)	471mW
Differential Input Voltage ($IN+$ to $IN-$)	6.6V	14-Pin TSSOP (derate 9.1mW/°C above +70°C)	727mW
Output Short-Circuit Duration	2s to Either V_{DD} or V_{SS}	14-Pin SO (derate 8.3mW/°C above +70°C)	667mW
Current into Any Pin	20mA	Operating Temperature Range	
Continuous Power Dissipation ($T_A = +70^\circ\text{C}$)		Automotive Application	-40°C to +125°C
5-Pin SC70 (derate 3.1mW/°C above +70°C)	247mW	Junction Temperature	+150°C
5-Pin SOT23 (derate 7.1mW/°C above +70°C)	571mW	Storage Temperature Range	-65°C to +150°C
8-Pin SOT23 (derate 9.1mW/°C above +70°C)	727mW	Lead Temperature (soldering, 10s)	+300°C

Stresses beyond those listed under "Absolute Maximum Ratings" may cause permanent damage to the device. These are stress ratings only, and functional operation of the device at these or any other conditions beyond those indicated in the operational sections of the specifications is not implied. Exposure to absolute maximum rating conditions for extended periods may affect device reliability.

ELECTRICAL CHARACTERISTICS

($V_{DD} = 5V$, $V_{SS} = 0$, $V_{CM} = 0$, $T_A = -40^\circ\text{C}$ to $+125^\circ\text{C}$, unless otherwise noted. Typical values are at $T_A = +25^\circ\text{C}$.) (Note 1)

PARAMETER	SYMBOL	CONDITIONS	MIN	TYP	MAX	UNITS	
Operating Voltage Range	V_{DD}	Guaranteed by PSRR test	2.5		5.5	V	
Supply Current Per Comparator	I_{DD}			2.8	5	μA	
Input Offset Voltage	V_{OS}	(Note 2)		± 1	± 8	mV	
Input Offset Voltage Temperature Coefficient	TCV_{OS}			± 1		$\mu\text{V}/^\circ\text{C}$	
Hysteresis		(Note 3)		4		mV	
Input Bias Current	I_{BIAS}			3	80	nA	
Input Offset Current	I_{OS}			± 2	± 60	nA	
Common-Mode Voltage Range	V_{CM}	Guaranteed by CMRR test	V_{SS}		$V_{DD} - 1.1$	V	
Common-Mode Rejection Ratio	CMRR	$V_{SS} \leq V_{CM} \leq (V_{DD} - 1.1V)$, $V_{DD} = 5.5V$	70	100		dB	
Power-Supply Rejection Ratio	PSRR	$V_{DD} = 2.5V$ to $5.5V$	60	80		dB	
Output-Voltage Swing	V_{OL} , V_{OH}	$V_{OH} = V_{DD} - V_{OUT}$, $(V_{IN+} - V_{IN-}) \geq 20mV$	$I_{SOURCE} = 10\mu\text{A}$		2	mV	
			$I_{SOURCE} = 4mA$		160		400
		$V_{OL} = V_{OUT} - V_{SS}$, $(V_{IN-} - V_{IN+}) \geq 20mV$	$I_{SINK} = 10\mu\text{A}$		2		
			$I_{SINK} = 4mA$		180		400
Output Short-Circuit Current	I_{SC}			50		mA	
Propagation Delay	t_{pd+} , t_{pd-}	$R_L = 10k\Omega$, $C_L = 15pF$ (Note 4)	$V_{OD} = 10mV$		8	μs	
			$V_{OD} = 100mV$		3		
Rise and Fall Time	t_R , t_F	$R_L = 10k\Omega$, $C_L = 15pF$ (Note 5)		20		ns	
Power-On Time		$R_L = 10k\Omega$, $C_L = 15pF$		150		ns	
Maximum Capacitive Load	C_L	No sustained oscillations		150		pF	

Note 1: All devices are production tested at 25°C. All temperature limits are guaranteed by design.

Note 2: Comparator Input Offset is defined as the center of the hysteresis zone.

Note 3: Hysteresis is defined as the difference of the trip points required to change comparator output states.

Note 4: V_{OD} is the overdrive voltage beyond the offset and hysteresis-determined trip points.

Note 5: Rise and fall times are measured between 10% and 90% at OUT.

Micropower, Ultra-Small, Single/Dual/Quad, Single-Supply Comparators

Typical Operating Characteristics

($V_{DD} = 5V$, $V_{SS} = 0$, $V_{CM} = 0$, $R_L = 10k\Omega$, $C_L = 15pF$, $V_{OD} = 100mV$, $T_A = +25^\circ C$, unless otherwise noted.)

MAX9021/MAX9022/MAX9024

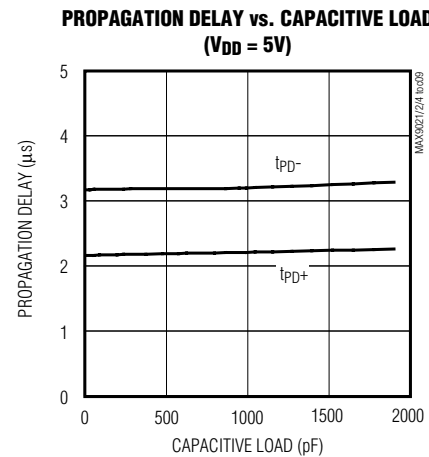
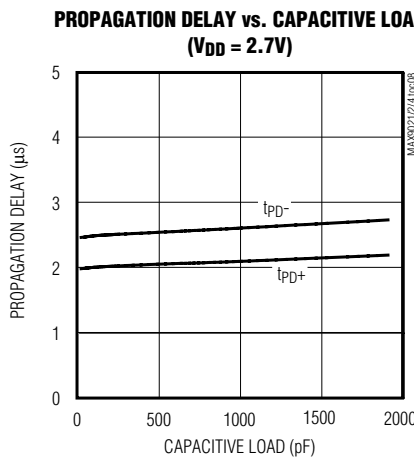
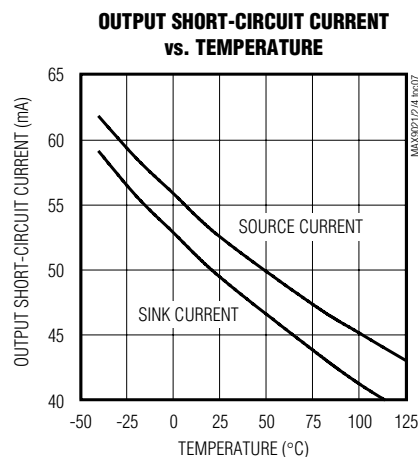
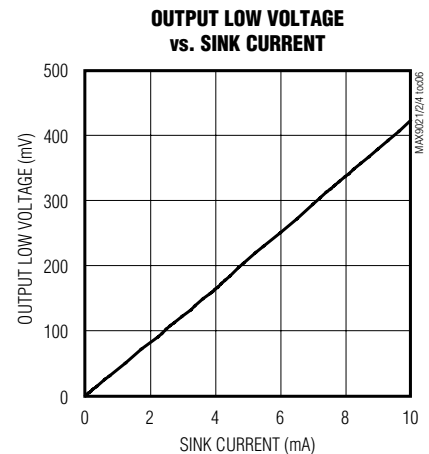
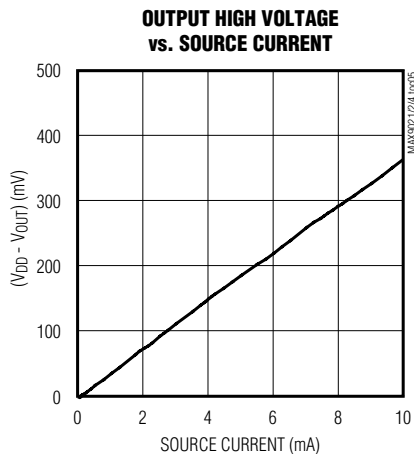
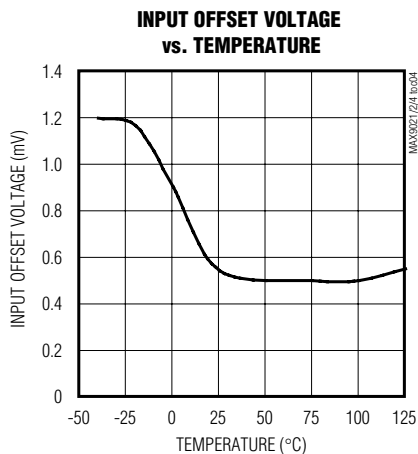
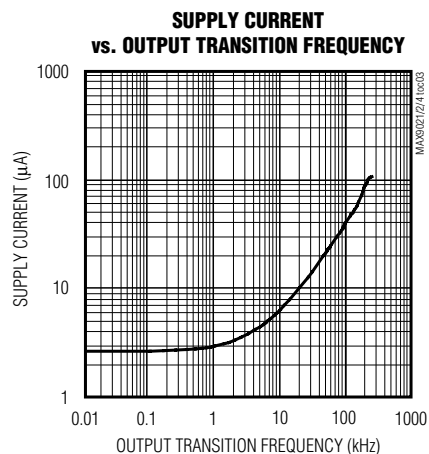
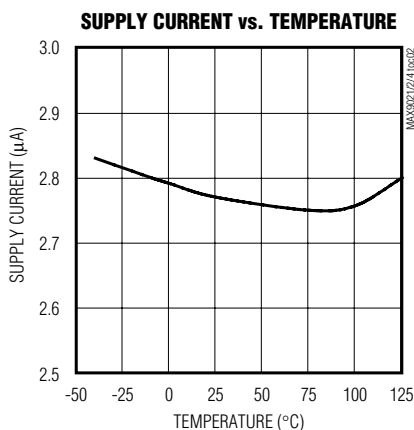
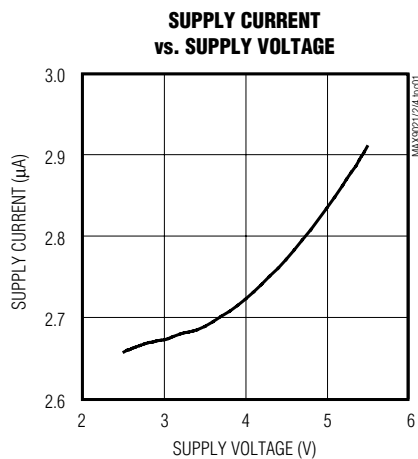

Micropower, Ultra-Small, Single/Dual/Quad, Single-Supply Comparators

Typical Operating Characteristics (continued)

($V_{DD} = 5V$, $V_{SS} = 0$, $V_{CM} = 0$, $R_L = 10k\Omega$, $C_L = 15pF$, $V_{OD} = 100mV$, $T_A = +25^\circ C$, unless otherwise noted.)

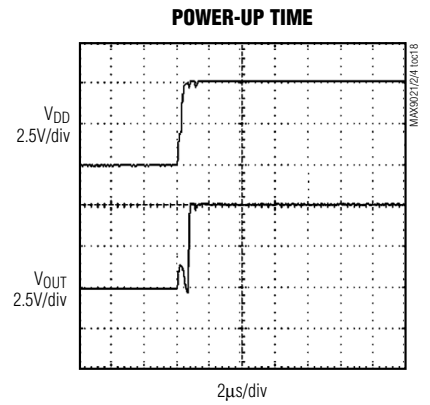
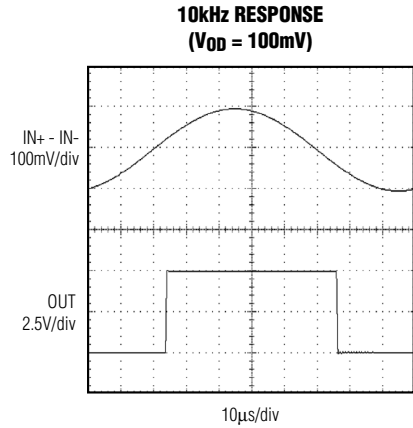
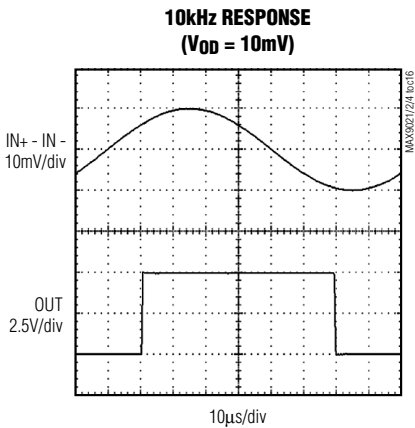
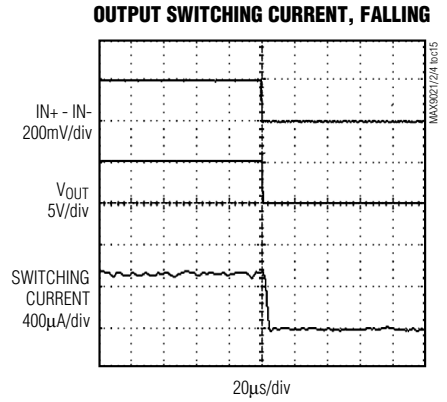
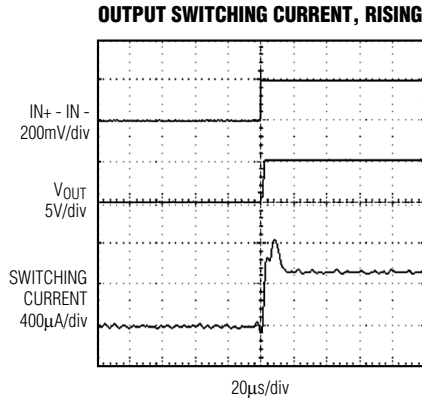
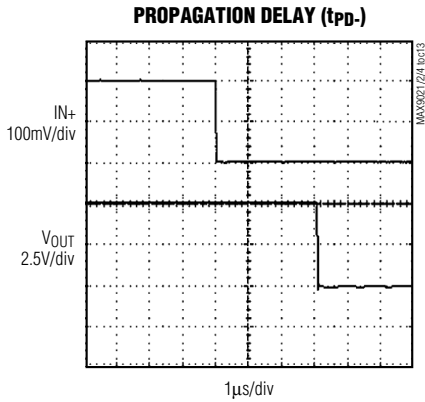
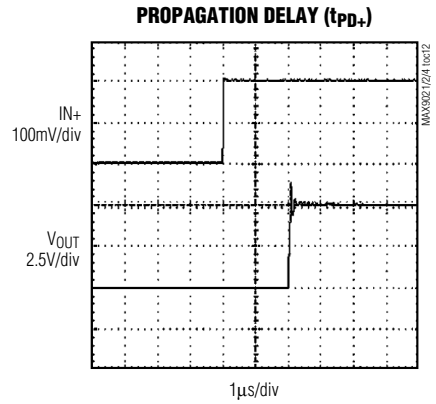
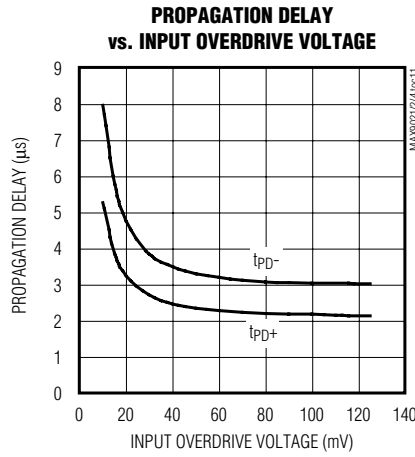
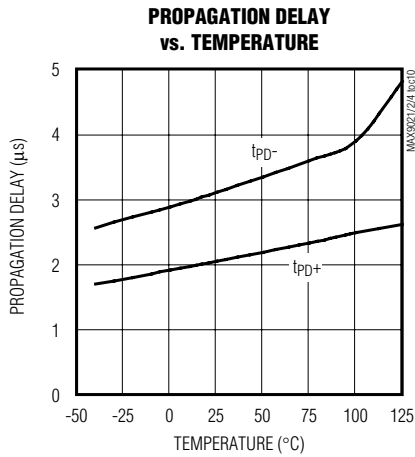

Micropower, Ultra-Small, Single/Dual/Quad, Single-Supply Comparators

Pin Description

MAX9021/MAX9022/MAX9024

PIN			NAME	FUNCTION
MAX9021	MAX9022	MAX9024		
1	—	—	IN+	Comparator Noninverting Input
2	4	11	V _{SS}	Negative Supply Voltage
3	—	—	IN-	Comparator Inverting Input
4	—	—	OUT	Comparator Output
5	8	4	V _{DD}	Positive Supply Voltage. Bypass with a 0.1μF capacitor to GND.
—	1	1	OUTA	Comparator A Output
—	2	2	INA-	Comparator A Inverting Input
—	3	3	INA+	Comparator A Noninverting Input
—	5	5	INB+	Comparator B Noninverting Input
—	6	6	INB-	Comparator B Inverting Input
—	7	7	OUTB	Comparator B Output
—	—	8	OUTC	Comparator C Output
—	—	9	INC-	Comparator C Inverting Input
—	—	10	INC+	Comparator C Noninverting Input
—	—	12	IND+	Comparator D Noninverting Input
—	—	13	IND-	Comparator D Inverting Input
—	—	14	OUTD	Comparator D Output

Detailed Description

The MAX9021/MAX9022/MAX9024 are single/dual/quad, low-cost, low-power comparators that consume only 2.8μA and provide a propagation delay, t_{PD}, typically 3μs. They have an operating-supply voltage from 2.5V to 5.5V when operating from a single supply and from ±1.25V to ±2.75V when operating from dual power supplies. Their common-mode input voltage range extends from the negative supply to within 1.1V of the positive supply. Internal hysteresis ensures clean output switching, even with slow-moving input signals.

Applications Information

Adding Hysteresis

Hysteresis extends the comparator's noise margin by increasing the upper threshold and decreasing the lower threshold. A voltage-divider from the compar-

ator's output sets the trip voltage. Therefore, the trip voltage is related to the output voltage.

These comparators have 4mV internal hysteresis. Additional hysteresis can be generated with two resistors, using positive feedback (Figure 1). Use the following procedure to calculate resistor values:

- 1) Find the trip points of the comparator using these formulas:

$$V_{TH} = V_{REF} + ((V_{DD} - V_{REF})R_2) / (R_1 + R_2)$$

$$V_{TL} = V_{REF}(1 - (R_2 / (R_1 + R_2)))$$

where V_{TH} is the threshold voltage at which the comparator switches its output from high to low as V_{IN} rises above the trip point. V_{TL} is the threshold voltage at which the comparator switches its output from low to high as V_{IN} drops below the trip point.

Micropower, Ultra-Small, Single/Dual/Quad, Single-Supply Comparators

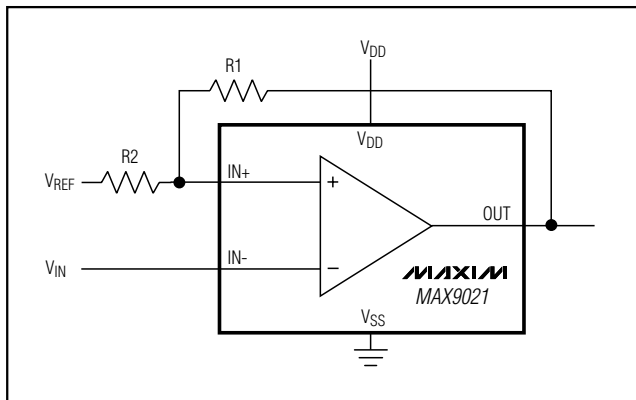

Figure 1. Additional Hysteresis

2) The hysteresis band will be:

$$V_{HYS} = V_{TH} - V_{TL} = V_{DD}(R2 / (R1 + R2))$$

3) In this example, let $V_{DD} = 5V$ and $V_{REF} = 2.5V$.

$$V_{TH} = 2.5V + 2.5V(R2 / (R1 + R2))$$

and

$$V_{TL} = 2.5V[(1 - (R2 / (R1 + R2)))]$$

4) Select $R2$. In this example, we will choose $1k\Omega$.

5) Select V_{HYS} . In this example, we will choose $50mV$.

6) Solve for $R1$.

$$V_{HYS} = V_{DD}(R2 / (R1 + R2))$$

$$0.050V = 5(1000\Omega / (R1 + 1000\Omega)) V$$

where $R1 \approx 100k\Omega$, $V_{TH} = 2.525V$, and $V_{TL} = 2.475V$.

The above-described design procedure assumes rail-to-rail output swing. If the output is significantly loaded, the results should be corrected.

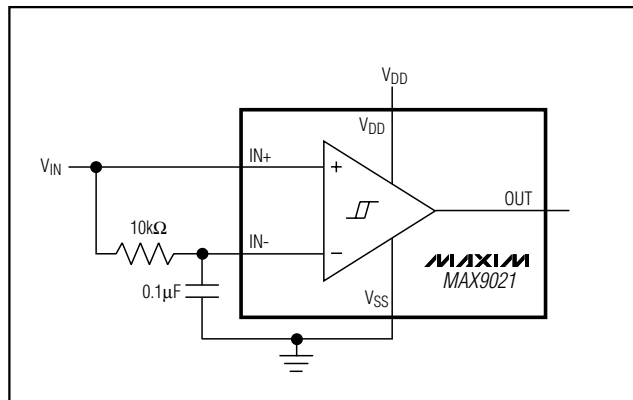

Figure 2. Time Averaging of the Input Signal for Data Recovery

Board Layout and Bypassing

Use $100nF$ bypass as a starting point. Minimize signal trace lengths to reduce stray capacitance. Minimize the capacitive coupling between $IN-$ and OUT . For slow-moving input signals (rise time $> 1ms$), use a $1nF$ capacitor between $IN+$ and $IN-$.

Biasing for Data Recovery

Digital data is often embedded into a bandwidth and amplitude-limited analog path. Recovering the data can be difficult. Figure 2 compares the input signal to a time-averaged version of itself. This self-biases the threshold to the average input voltage for optimal noise margin. Even severe phase distortion is eliminated from the digital output signal. Be sure to choose $R1$ and $C1$ so that:

$$f_{CAR} \gg 1 / (2\pi R1 C1)$$

where f_{CAR} is the fundamental carrier frequency of the digital data stream.

Micropower, Ultra-Small, Single/Dual/Quad, Single-Supply Comparators

Typical Application Circuit

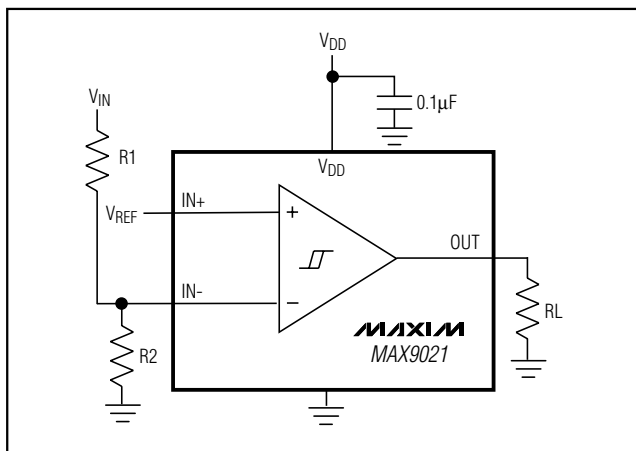

Chip Information

MAX9021 TRANSISTOR COUNT: 106
 MAX9022 TRANSISTOR COUNT: 212
 MAX9024 TRANSISTOR COUNT: 424

Package Information

(The package drawing(s) in this data sheet may not reflect the most current specifications. For the latest package outline information, go to www.maxim-ic.com/packages.)

SYMBOL	MIN	MAX
e	0.65	BSC
D	1.80	2.20
b	0.15	0.30
E	1.15	1.35
HE	1.80	2.40
Q1	0.10	0.40
A2	0.80	1.00
A1	0.00	0.10
A	0.80	1.10
c	0.10	0.18
L	0.10	0.30
L1	0.425	TYP.

SC70-5LEPS

NOTE:

1. ALL DIMENSIONS ARE IN MILLIMETERS
2. DIMENSIONS ARE INCLUSIVE OF PLATING
3. DIMENSIONS ARE EXCLUSIVE OF MOLD FLASH & METAL BURR
4. ALL SPECIFICATIONS COMPLY TO EIAJ SC70
5. COPLANARITY 4 MILS. MAX.

MAXIM		
PROPRIETARY INFORMATION		
TITLE:		
PACKAGE OUTLINE, SC70, 5L		
APPROVAL	DOCUMENT CONTROL NO.	REV
	21-0076	B 1/1

MAX9021/MAX9022/MAX9024

Micropower, Ultra-Small, Single/Dual/Quad, Single-Supply Comparators

Package Information (continued)

(The package drawing(s) in this data sheet may not reflect the most current specifications. For the latest package outline information, go to www.maxim-ic.com/packages.)

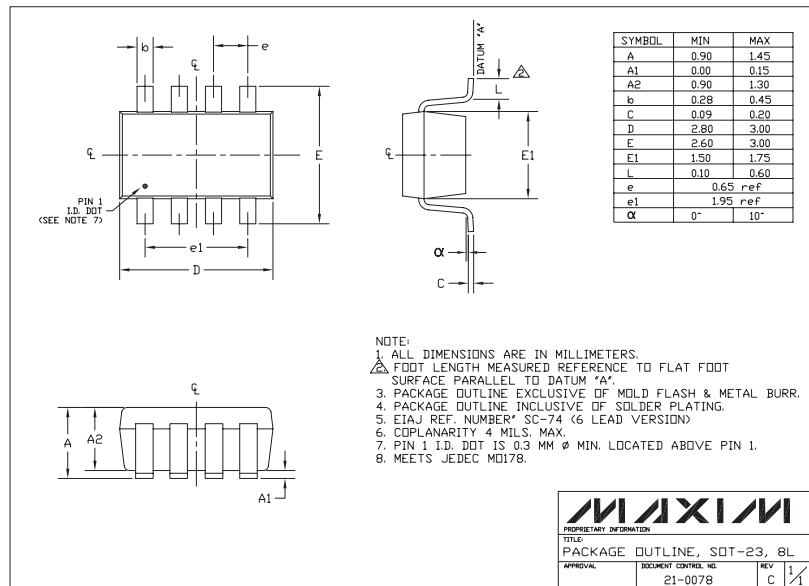
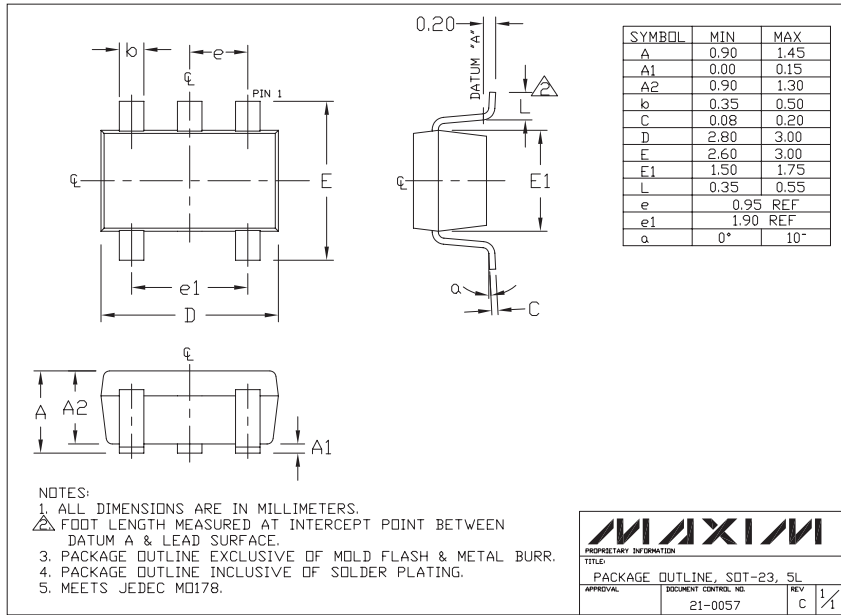

Maxim cannot assume responsibility for use of any circuitry other than circuitry entirely embodied in a Maxim product. No circuit patent licenses are implied. Maxim reserves the right to change the circuitry and specifications without notice at any time.

8 **Maxim Integrated Products, 120 San Gabriel Drive, Sunnyvale, CA 94086 408-737-7600**