



Integrated
Circuit
Systems, Inc.

ICS8302

LOW SKEW, 1-TO-2 LVCMOS / LVTTTL FANOUT BUFFER

GENERAL DESCRIPTION



The ICS8302 is a low skew, 1-to-2 LVCMOS Fanout Buffer and a member of the HiPerClockS™ family of High Performance Clock Solutions from ICS. The ICS8302 has a single ended clock input. The single ended clock input accepts LVCMOS or LVTTTL input levels. The ICS8302 features a pair of LVCMOS/LVTTTL outputs. The ICS8302 is characterized at full 3.3V for input V_{DD} , and mixed 3.3V and 2.5V for output operating supply modes (V_{DDO}). Guaranteed output and part-to-part skew characteristics make the ICS8302 ideal for clock distribution applications demanding well defined performance and repeatability.

FEATURES

- 2 LVCMOS / LVTTTL outputs
- LVCMOS / LVTTTL clock input accepts LVCMOS or LVTTTL input levels
- Maximum output frequency: 200MHz
- Output skew: 25ps (typical)
- Part-to-part skew: 250ps (typical)
- Small 8 lead SOIC package saves board space
- Full 3.3V or 3.3V core, 2.5V supply modes
- 0°C to 70°C ambient operating temperature
- Lead-Free package available
- Industrial temperature information available upon request

BLOCK DIAGRAM

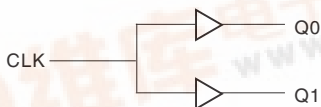

PIN ASSIGNMENT

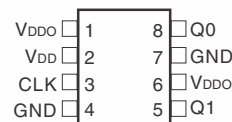

ICS8302
8-Lead SOIC

3.8mm x 4.8mm, x 1.47mm package body

M Package
Top View





Integrated
Circuit
Systems, Inc.

ICS8302

LOW SKEW, 1-TO-2 LVCMOS / LVTTTL FANOUT BUFFER

TABLE 1. PIN DESCRIPTIONS

Number	Name	Type		Description
1, 6	V_{DDO}	Power		Output supply pins.
2	V_{DD}	Power		Core supply pin.
3	CLK	Input	Pulldown	LVCMOS / LVTTTL clock input.
4,7	GND	Power		Power supply ground.
5	Q1	Output		Single clock output. LVCMOS / LVTTTL interface levels.
8	Q0	Output		Single clock output. LVCMOS / LVTTTL interface levels.

NOTE: *Pullup* and *Pulldown* refer to internal input resistors. See Table 2, Pin Characteristics, for typical values.

TABLE 2. PIN CHARACTERISTICS

Symbol	Parameter	Test Conditions	Minimum	Typical	Maximum	Units
C_{IN}	Input Capacitance			4		pF
C_{PD}	Power Dissipation Capacitance (per output)	$V_{DD}, V_{DDO} = 3.465V$		22		pF
		$V_{DD} = 3.465V, V_{DDO} = 2.625V$		16		pF
$R_{PULLDOWN}$	Input Pulldown Resistor			51		K Ω
R_{OUT}	Output Impedance		5	7	12	Ω



ABSOLUTE MAXIMUM RATINGS

Supply Voltage, V_{DD}	4.6V
Inputs, V_I	-0.5V to $V_{DD} + 0.5V$
Outputs, V_O	-0.5V to $V_{DDO} + 0.5V$
Package Thermal Impedance, θ_{JA}	112.7°C/W (0 lfpm)
Storage Temperature, T_{STG}	-65°C to 150°C

NOTE: Stresses beyond those listed under Absolute Maximum Ratings may cause permanent damage to the device. These ratings are stress specifications only. Functional operation of product at these conditions or any conditions beyond those listed in the *DC Characteristics* or *AC Characteristics* is not implied. Exposure to absolute maximum rating conditions for extended periods may affect product reliability.

TABLE 3A. POWER SUPPLY DC CHARACTERISTICS, $V_{DD} = V_{DDO} = 3.3V \pm 5\%$, $T_A = 0^\circ C$ TO $70^\circ C$

Symbol	Parameter	Test Conditions	Minimum	Typical	Maximum	Units
V_{DD}	Core Supply Voltage		3.135	3.3	3.465	V
V_{DDO}	Output Power Supply Voltage		3.135	3.3	3.465	V
I_{DD}	Power Supply Current				13	mA
I_{DDO}	Output Supply Current				4	mA

TABLE 3B. LVCMOS / LVTTTL DC CHARACTERISTICS, $V_{DD} = V_{DDO} = 3.3V \pm 5\%$, $T_A = 0^\circ C$ TO $70^\circ C$

Symbol	Parameter	Test Conditions	Minimum	Typical	Maximum	Units
V_{IH}	Input High Voltage		2		$V_{DD} + 0.3$	V
V_{IL}	Input Low Voltage		-0.3		1.3	V
I_{IH}	Input High Current	CLK $V_{DD} = V_{IN} = 3.465V$			150	μA
I_{IL}	Input Low Current	CLK $V_{DD} = 3.465V, V_{IN} = 0V$	-5			μA
V_{OH}	Output High Voltage	50Ω to $V_{DDO}/2$	2.6			V
		$I_{OH} = -100\mu A$	2.9			V
V_{OL}	Output Low Voltage	50Ω to $V_{DDO}/2$			0.5	V
		$I_{OL} = 100\mu A$			0.2	V

TABLE 4A. AC CHARACTERISTICS, $V_{DD} = V_{DDO} = 3.3V \pm 5\%$, $T_A = 0^\circ C$ TO $70^\circ C$

Symbol	Parameter	Test Conditions	Minimum	Typical	Maximum	Units
f_{MAX}	Output Frequency				200	MHz
tp_{LH}	Propagation Delay, Low-to-High; NOTE 1	$f \leq 200MHz$	1.9	2.35	2.8	ns
$t_{sk(o)}$	Output Skew; NOTE 2, 4			25	85	ps
$t_{sk(pp)}$	Part-to-Part Skew; NOTE 3, 4			250	800	ps
t_R	Output Rise Time	20% to 80%	300		800	ps
t_F	Output Fall Time	20% to 80%	300		800	ps
odc	Output Duty Cycle	$f \leq 133MHz$	45		55	%
		$133MHz < f \leq 200MHz$	40		60	%

Parameters measured at f_{MAX} unless otherwise noted.

NOTE 1: Measured from $V_{DD}/2$ of the input to $V_{DDO}/2$ of the output.

NOTE 2: Defined as skew between outputs at the same supply voltage and with equal load conditions. Measured at $V_{DDO}/2$.

NOTE 3: Defined as skew between outputs on different devices operating at the same supply voltages and with equal load conditions. Using the same type of inputs on each device, the outputs are measured at $V_{DDO}/2$.

NOTE 4: This parameter is defined in accordance with JEDEC Standard 65.



Integrated
Circuit
Systems, Inc.

ICS8302

LOW SKEW, 1-TO-2 LVCMOS / LVTTTL FANOUT BUFFER

TABLE 3C. POWER SUPPLY DC CHARACTERISTICS, $V_{DD} = 3.3V \pm 5\%$, $V_{DDO} = 2.5V \pm 5\%$, $T_A = 0^\circ C$ TO $70^\circ C$

Symbol	Parameter	Test Conditions	Minimum	Typical	Maximum	Units
V_{DD}	Core Supply Voltage		3.135	3.3	3.465	V
V_{DDO}	Output Supply Voltage		2.375	2.5	2.625	V
I_{DD}	Power Supply Current				13	mA
I_{DDO}	Output Supply Current				4	mA

TABLE 3D. LVCMOS / LVTTTL DC CHARACTERISTICS, $V_{DD} = 3.3V \pm 5\%$, $V_{DDO} = 2.5V \pm 5\%$, $T_A = 0^\circ C$ TO $70^\circ C$

Symbol	Parameter	Test Conditions	Minimum	Typical	Maximum	Units
V_{IH}	Input High Voltage		2		$V_{DD} + 0.3$	V
V_{IL}	Input Low Voltage		-0.3		1.3	V
I_{IH}	Input High Current	CLK $V_{DD} = V_{IN} = 3.465V$			150	μA
I_{IL}	Input Low Current	CLK $V_{DD} = 3.465V, V_{IN} = 0V$	-5			μA
V_{OH}	Output High Voltage	50Ω to $V_{DDO}/2$	1.8			V
		$I_{OH} = -100\mu A$	2.2			V
V_{OL}	Output Low Voltage	50Ω to $V_{DDO}/2$			0.5	V
		$I_{OL} = 100\mu A$			0.2	V

TABLE 4B. AC CHARACTERISTICS, $V_{DD} = 3.3V \pm 5\%$, $V_{DDO} = 2.5V \pm 5\%$, $T_A = 0^\circ C$ TO $70^\circ C$

Symbol	Parameter	Test Conditions	Minimum	Typical	Maximum	Units
f_{MAX}	Output Frequency				200	MHz
tp_{LH}	Propagation Delay, Low-to-High; NOTE 1	$f \leq 200MHz$	2.3		3.3	ns
$t_{sk(o)}$	Output Skew; NOTE 2, 4				85	ps
$t_{sk(pp)}$	Part-to-Part Skew; NOTE 3, 4			250	800	ps
t_R	Output Rise Time	20% to 80%	250		650	ps
t_F	Output Fall Time	20% to 80%	250		650	ps
odc	Output Duty Cycle	$f \leq 133MHz$	45		55	%
		$133MHz < f \leq 200MHz$	40		60	%

Parameters measured at f_{MAX} unless otherwise noted.

NOTE 1: Measured from $V_{DD}/2$ of the input to $V_{DDO}/2$ of the output.

NOTE 2: Defined as skew between outputs at the same supply voltage and with equal load conditions.

Measured at $V_{DDO}/2$.

NOTE 3: Defined as skew between outputs on different devices operating at the same supply voltages and with equal load conditions. Using the same type of inputs on each device, the outputs are measured at $V_{DDO}/2$.

NOTE 4: This parameter is defined in accordance with JEDEC Standard 65.



PARAMETER MEASUREMENT INFORMATION

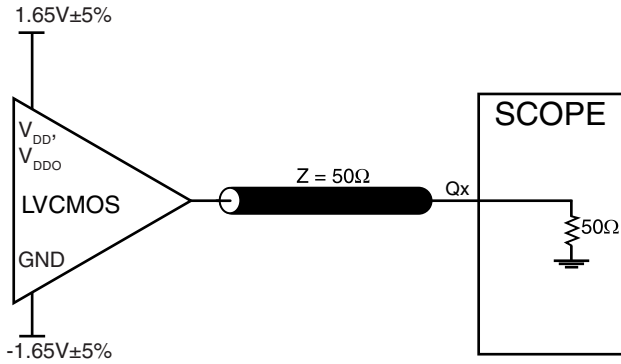

3.3V OUTPUT LOAD AC TEST CIRCUIT

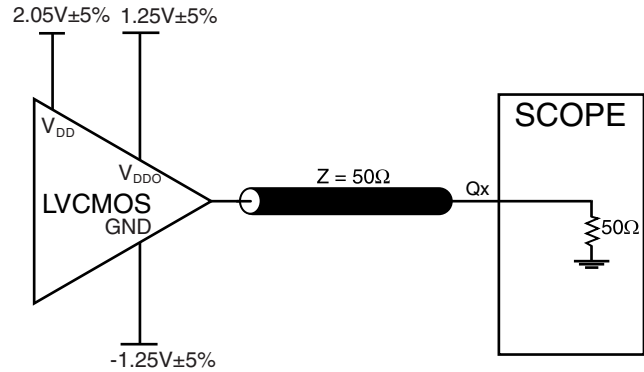

3.3V/2.5V OUTPUT LOAD AC TEST CIRCUIT

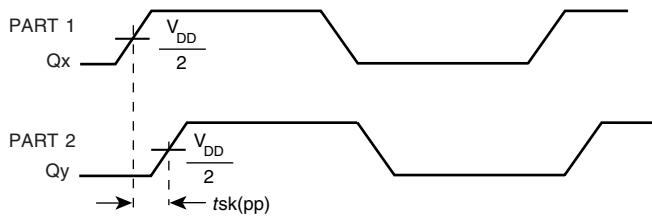

PART-TO-PART SKEW

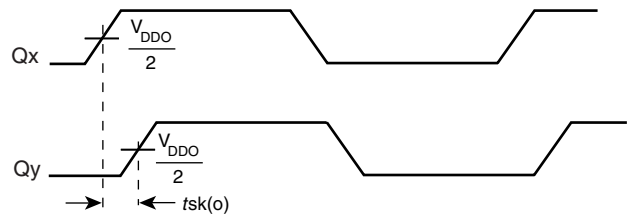

OUTPUT SKEW

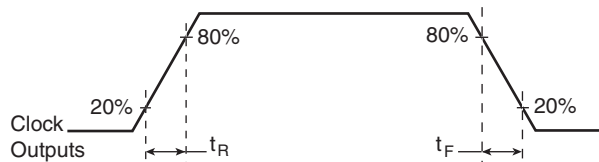

OUTPUT RISE/FALL TIME

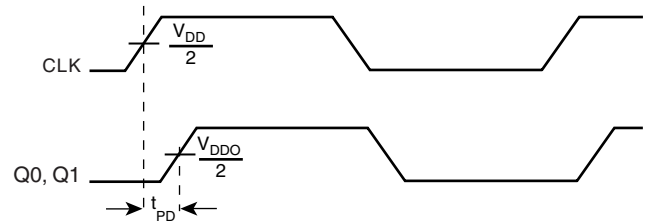

PROPAGATION DELAY

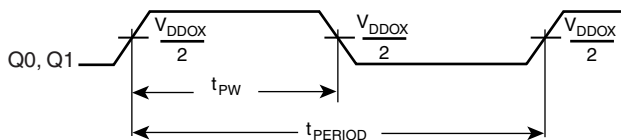

$$odc = \frac{t_{PW}}{t_{PERIOD}}$$

OUTPUT PULSE WIDTH/PERIOD



RELIABILITY INFORMATION

TABLE 5. θ_{JA} VS. AIR FLOW TABLE FOR 8 LEAD SOIC

θ_{JA} by Velocity (Linear Feet per Minute)			
	0	200	500
Single-Layer PCB, JEDEC Standard Test Boards	153.3°C/W	128.5°C/W	115.5°C/W
Multi-Layer PCB, JEDEC Standard Test Boards	112.7°C/W	103.3°C/W	97.1°C/W

NOTE: Most modern PCB designs use multi-layered boards. The data in the second row pertains to most designs.

TRANSISTOR COUNT

The transistor count for ICS8302 is: 322



PACKAGE OUTLINE - SUFFIX M FOR 8 LEAD SOIC

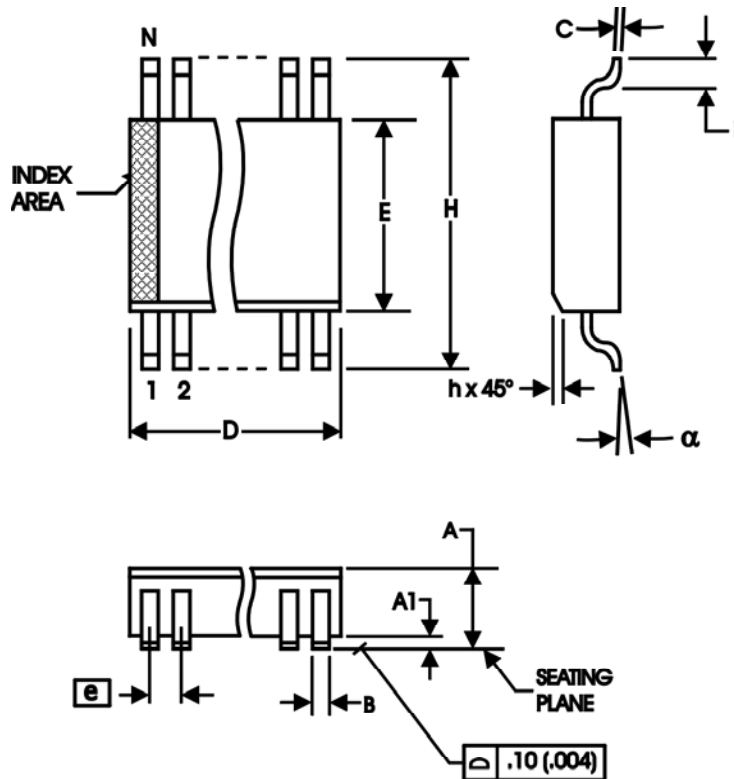

TABLE 6. PACKAGE DIMENSIONS

SYMBOL	Millimeters	
	MINIMUM	MAXIMUM
N	8	
A	1.35	1.75
A1	0.10	0.25
B	0.33	0.51
C	0.19	0.25
D	4.80	5.00
E	3.80	4.00
e	1.27 BASIC	
H	5.80	6.20
h	0.25	0.50
L	0.40	1.27
α	0°	8°

Reference Document: JEDEC Publication 95, MS-012



Integrated
Circuit
Systems, Inc.

ICS8302

LOW SKEW, 1-TO-2 LVCMOS / LVTTTL FANOUT BUFFER

TABLE 7. ORDERING INFORMATION

Part/Order Number	Marking	Package	Count	Temperature
ICS8302AM	8302AM	8 lead SOIC	96 per tube	0°C to 70°C
ICS8302AMT	8302AM	8 lead SOIC on Tape and Reel	2500	0°C to 70°C
ICS8302AMLF	8302AMLF	8 lead "Lead Free" SOIC	96 per tube	0°C to 70°C
ICS8302AMLFT	8302AMLF	8 lead "Lead Free" SOIC on Tape and Reel	2500	0°C to 70°C

The aforementioned trademark, HiPerClockS™ is a trademark of Integrated Circuit Systems, Inc. or its subsidiaries in the United States and/or other countries.

While the information presented herein has been checked for both accuracy and reliability, Integrated Circuit Systems, Incorporated (ICS) assumes no responsibility for either its use or for infringement of any patents or other rights of third parties, which would result from its use. No other circuits, patents, or licenses are implied. This product is intended for use in normal commercial applications. Any other applications such as those requiring extended temperature range, high reliability, or other extraordinary environmental requirements are not recommended without additional processing by ICS. ICS reserves the right to change any circuitry or specifications without notice. ICS does not authorize or warrant any ICS product for use in life support devices or critical medical instruments.



Integrated
Circuit
Systems, Inc.

ICS8302
LOW SKEW, 1-TO-2
LVCMOS / LVTTTL FANOUT BUFFER

REVISION HISTORY SHEET				
Rev	Table	Page	Description of Change	Date
B	T1	2	Pin Description table, revised V_{DD} description.	2/4/03
	T2	2	Pin Characteristics table, deleted R_{PULLUP} row.	
	T3A & T3C	3, 4	Power Supply table, changed V_{DD} parameter to correspond with description.	
	T4A & T4B	3, 4	AC Characteristics tables - added note "Parameters measured at f_{MAX} unless otherwise noted." $t_{p_{LH}}$ Test Conditions, added $f \leq 200\text{MHz}$.	
C	T2	2	Pin Characteristics table - changed C_{IN} 4pF max. to 4pF typical. Added 5 Ω min. and 12 Ω max. to R_{OUT} row.	6/15/04
	T7	8	Ordering Information table - added "Lead-Free" part number.	