



# MIC7122

## Rail-to-Rail Dual Op Amp

### Preliminary Information

### General Description

The MIC7122 is a dual high-performance CMOS operational amplifier featuring rail-to-rail inputs and outputs.

The input common-mode range extends beyond the rails by 300mV, and the output voltage swings to within 150μV of both rails when driving a 100kΩ load.

The amplifiers operate from 2.2V to 15V and are fully specified at 2.2V, 5V, and 15V. Gain bandwidth and slew rate are 750kHz and 0.7V/μs, respectively at 2.2V supply.

The MIC7122 is available in the MM8™ 8-lead MSOP package.

### Features

- Small footprint MSOP-8 package
- 350μA supply current per op amp at 2.2V supply
- Guaranteed 2.2V, 5V, and 15V performance
- 750kHz gain-bandwidth product at 2.2V supply
- 0.01% total harmonic distortion at 1kHz (15V, 2kΩ)
- Drives 200pF at 5V and greater supply voltages

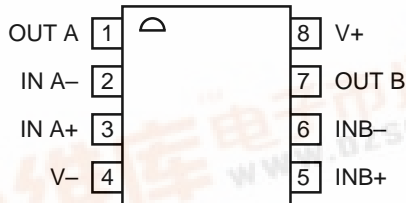
### Applications

- Battery-powered instrumentation
- PCMCIA, USB peripherals
- Portable computers and PDAs

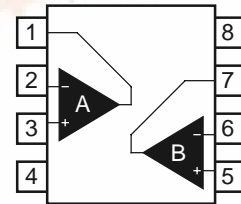
### Ordering Information

Part Number	Temperature Range	Package
MIC7122BMM	-40°C to +85°C	MSOP-8

### Pin Configuration



MSOP-8 (MM)



### Pin Description

Pin Number	Pin Name	Pin Function
1 / 7	OUTA / OUTB	Amplifier Outputs
2 / 6	INA- / INB-	Inverting Inputs
3 / 5	INA+ / INB+	Noninverting Inputs
4	V-	Negative Supply: Negative supply for split supply application or ground for single supply applications.
8	V+	Positive Supply

**Absolute Maximum Ratings (Note 1)**

Supply Voltage ( $V_{V+} - V_{V-}$ )	16.5V
Differential Input Voltage ( $V_{IN+} - V_{IN-}$ )	$\pm 10V$
I/O Pin Voltage ( $V_{IN}, V_{OUT}$ ), <b>Note 3</b>	
.....	$V_{V+} + 0.3V$ to $V_{V-} - 0.3V$
Junction Temperature ( $T_J$ )	+150°C
Storage Temperature	-65°C to +150°C
Lead Temperature (soldering, 10 sec.)	260°C
ESD, <b>Note 6</b>	1000V

**Operating Ratings (Note 2)**

Supply Voltage ( $V_{V+} - V_{V-}$ )	2.2V to 15V
Junction Temperature ( $T_J$ )	-40°C to +85°C
Max. Junction Temperature ( $T_{J(max)}$ ), <b>Note 4</b>	+125°C
Max. Power Dissipation	<b>Note 4</b>
Package Thermal Resistance, <b>Note 5</b>	
MSOP-8 ( $\theta_{JA}$ )	200°C/W

**DC Electrical Characteristics (2.2V)**

$V_{V+} = +2.2V$ ,  $V_{V-} = 0V$ ,  $V_{CM} = V_{OUT} = V_{V+}/2$ ;  $R_L = 1M\Omega$ ;  $T_J = 25^\circ C$ , **bold** values indicate  $-40^\circ C \leq T_J \leq +85^\circ C$ ; **Note 7**; unless noted

Symbol	Parameter	Condition	Min	Typ	Max	Units
$V_{OS}$	Input Offset Voltage			0.5	9	mV
$TCV_{OS}$	Input Offset Voltage Average Drift			3.0		$\mu V/^\circ C$
$I_B$	Input Bias Current			1.0 <b>64</b>	10 <b>500</b>	pA pA
$I_{OS}$	Input Offset Current			0.5 <b>32</b>	5 <b>250</b>	pA pA
$R_{IN}$	Input Resistance			>1		$T\Omega$
CMRR	Common-Mode Rejection Ratio	$-0.3V \leq V_{CM} \leq 2.5V$ , <b>Note 9</b>	45	65		dB
$\pm PSRR$	Power Supply Rejection Ratio	$V_{V+} =  V_{V-}  = 1.1V$ to $2.5V$ , $V_{OUT} = V_{CM} = 0$	60	85		dB
$C_{IN}$	Common-Mode Input Capacitance			3		pF
$V_O$	Output Swing	output high, $R_L = 100k$ , specified as $V_{V+} - V_{OUT}$		0.15	1 <b>1</b>	mV mV
		output low, $R_L = 100k$		0.15	1 <b>1</b>	mV mV
		output high, $R_L = 2k$ specified as $V_{V+} - V_{OUT}$		8	33 <b>50</b>	mV mV
		output low, $R_L = 2k$		8	33 <b>50</b>	mV mV
		output high, $R_L = 600\Omega$ specified as $V_{V+} - V_{OUT}$		26	110 <b>165</b>	mV mV
		output low, $R_L = 600\Omega$		26	110 <b>165</b>	mV mV
$I_{SC}$	Output Short Circuit Current	sinking or sourcing, <b>Note 8</b>	20	50		mA
$I_S$	Supply Current	both amplifiers		0.7	1.6	mA

**AC Electrical Characteristics (2.2V)**

$V_{V+} = 2.2V$ ,  $V_{V-} = 0V$ ,  $V_{CM} = V_{OUT} = V_{V+}/2$ ;  $R_L = 1M\Omega$ ;  $T_J = 25^\circ C$ , **bold** values indicate  $-40^\circ C \leq T_J \leq +85^\circ C$ ; **Note 7**; unless noted

Symbol	Parameter	Condition	Min	Typ	Max	Units
SR	Slew Rate			0.7		V/ $\mu s$
GBW	Gain-Bandwidth Product			750		kHz
$\phi_m$	Phase Margin	$C_L = 0pF$		80		$^\circ$
		$C_L = 200pF$		40		$^\circ$
$G_m$	Gain Margin			10		dB
	Interamplifier Isolation	<b>Note 12</b>		90		dB

## DC Electrical Characteristics (5V)

$V_{V+} = +5.0V$ ,  $V_{V-} = 0V$ ,  $V_{CM} = 1.5V$ ,  $V_{OUT} = V_{V+}/2$ ;  $R_L = 1M\Omega$ ;  $T_J = 25^\circ C$ , **bold** values indicate  $-40^\circ C \leq T_J \leq +85^\circ C$ ; **Note 7**; unless noted

Symbol	Parameter	Condition	Min	Typ	Max	Units
$V_{OS}$	Input Offset Voltage			0.5	9	mV
$TCV_{OS}$	Input Offset Voltage Average Drift			3.0		$\mu V/^\circ C$
$I_B$	Input Bias Current			1.0 <b>64</b>	10 <b>500</b>	pA pA
$I_{OS}$	Input Offset Current			0.5 <b>32</b>	5 <b>250</b>	pA pA
$R_{IN}$	Input Resistance			>1		$T\Omega$
CMRR	Common-Mode Rejection Ratio	$-0.3V \leq V_{CM} \leq 5.3V$ , <b>Note 9</b>	55	75		dB
$\pm PSRR$	Power Supply Rejection Ratio	$V_{V+} =  V_{V-}  = 2.5V$ to $7.5V$ , $V_{OUT} = V_{CM} = 0$	55	100		dB
$C_{IN}$	Common-Mode Input Capacitance			3		pF
$V_{OUT}$	Output Swing	output high, $R_L = 100k$ specified as $V_{V+} - V_{OUT}$		0.3	1.0 <b>1.5</b>	mV mV
		output low, $R_L = 100k$		0.3	1.0 <b>1.5</b>	mV mV
		output high, $R_L = 2k$ specified as $V_{V+} - V_{OUT}$		13	50 <b>75</b>	mV mV
		output low, $R_L = 2k$		13	50 <b>75</b>	mV mV
		output high, $R_L = 600\Omega$ specified as $V_{V+} - V_{OUT}$		40	165 <b>250</b>	mV mV
		output low, $R_L = 600\Omega$		40	165 <b>250</b>	mV mV
$I_{SC}$	Output Short Circuit Current	sinking or sourcing, <b>Note 8</b>	40	140		mA
$I_S$	Supply Current	both amplifiers		0.8	1.8	mA

## AC Electrical Characteristics (5V)

$V_{V+} = 5V$ ,  $V_{V-} = 0V$ ,  $V_{CM} = 1.5V$ ,  $V_{OUT} = V_{V+}/2$ ;  $R_L = 1M\Omega$ ;  $T_J = 25^\circ C$ , **bold** values indicate  $-40^\circ C \leq T_J \leq +85^\circ C$ ; **Note 7**; unless noted

Symbol	Parameter	Condition	Min	Typ	Max	Units
THD	Total Harmonic Distortion	$f = 1kHz$ , $A_V = -2$ , $R_L = 2k\Omega$ , $V_{OUT} = 4.0 V_{PP}$		0.05		%
SR	Slew Rate			0.6		$V/\mu s$
GBW	Gain-Bandwidth Product			465		kHz
$\phi_m$	Phase Margin	$C_L = 0pF$		85		$^\circ$
		$C_L = 200pF$		40		$^\circ$
$G_m$	Gain Margin			10		dB
	Interamplifier Isolation	<b>Note 12</b>		90		dB

**DC Electrical Characteristics (15V)**
 $V_{V+} = +15V$ ,  $V_{V-} = 0V$ ,  $V_{CM} = 1.5V$ ,  $V_{OUT} = V_{V+}/2$ ;  $R_L = 1M\Omega$ ;  $T_J = 25^\circ C$ , **bold values indicate  $-40^\circ C \leq T_J \leq +85^\circ C$ ; Note 7**; unless noted

Symbol	Parameter	Condition	Min	Typ	Max	Units
$V_{OS}$	Input Offset Voltage			0.5	9	mV
$TCV_{OS}$	Input Offset Voltage Average Drift			3.0		$\mu V/^\circ C$
$I_B$	Input Bias Current			1.0 <b>64</b>	10 <b>500</b>	pA pA
$I_{OS}$	Input Offset Current			0.5 <b>32</b>	5 <b>250</b>	pA pA
$R_{IN}$	Input Resistance			>1		$T\Omega$
CMRR	Common-Mode Rejection Ratio	$-0.3V \leq V_{CM} \leq 15.3V$ , <b>Note 9</b>	60	85		dB
$\pm PSRR$	Power Supply Rejection Ratio	$V_{V+} =  V_{V-}  = 2.5V$ to $7.5V$ , $V_{OUT} = V_{CM} = 0$	55	100		dB
$A_V$	Large Signal Voltage Gain	sourcing or sinking, $R_L = 2k$ , <b>Note 10</b>		340		V/mV
		sourcing or sinking, $R_L = 600\Omega$ , <b>Note 10</b>		300		V/mV
$C_{IN}$	Common-Mode Input Capacitance			3		pF
$V_{OUT}$	Output Swing	output high, $R_L = 100k$ specified as $V_{V+} - V_{OUT}$		0.8	2 <b>3</b>	mV mV
		output low, $R_L = 100k$		0.8	2 <b>3</b>	mV mV
		output high, $R_L = 2k$ specified as $V_{V+} - V_{OUT}$		40	80 <b>120</b>	mV mV
		output low, $R_L = 2k$		40	80 <b>120</b>	mV mV
		output high, $R_L = 600\Omega$ specified as $V_{V+} - V_{OUT}$		130	270 <b>400</b>	mV mV
		output low, $R_L = 600\Omega$		130	270 <b>400</b>	mV mV
$I_{SC}$	Output Short Circuit Current	sinking or sourcing, <b>Notes 8</b>	50	250		mA
$I_S$	Supply Current	both amplifiers		0.9	2.0	mA

**AC Electrical Characteristics (15V)**
 $V_{V+} = 15V$ ,  $V_{V-} = 0V$ ,  $V_{CM} = 1.5V$ ,  $V_{OUT} = V_{V+}/2$ ;  $R_L = 1M\Omega$ ;  $T_J = 25^\circ C$ , **bold values indicate  $-40^\circ C \leq T_J \leq +85^\circ C$ ; Note 7**; unless noted

Symbol	Parameter	Condition	Min	Typ	Max	Units
THD	Total Harmonic Distortion	$f = 1kHz$ , $A_V = -2$ , $R_L = 2k$ , $V_{OUT} = 8.5 V_{PP}$		0.01		%
SR	Slew Rate	$V_+ = 15V$ , <b>Note 11</b>		0.5		V/ $\mu s$
GBW	Gain-Bandwidth Product			420		kHz
$\phi_m$	Phase Margin	$C_L = 0pF$		85		$^\circ$
		$C_L = 500pF$		40		$^\circ$
$G_m$	Gain Margin			10		dB
$e_n$	Input-Referred Voltage Noise	$f = 1kHz$ , $V_{CM} = 1V$		37		$nV/\sqrt{Hz}$
$i_n$	Input-Referred Current Noise	$f = 1kHz$		1.5		$fA/\sqrt{Hz}$
	Interamplifier Isolation	<b>Note 12</b>		90		dB

- Note 1.** Exceeding the absolute maximum rating may damage the device.
- Note 2.** The device is not guaranteed to function outside its operating rating.
- Note 3.** I/O Pin Voltage is any external voltage to which an input or output is referenced.
- Note 4.** The maximum allowable power dissipation is a function of the maximum junction temperature,  $T_{J(max)}$ ; the junction-to-ambient thermal resistance,  $\theta_{JA}$ ; and the ambient temperature,  $T_A$ . The maximum allowable power dissipation at any ambient temperature is calculated using:  $P_D = (T_{J(max)} - T_A) \div \theta_{JA}$ . Exceeding the maximum allowable power dissipation will result in excessive die temperature.
- Note 5.** Thermal resistance,  $\theta_{JA}$ , applies to a part soldered on a printed-circuit board.
- Note 6.** Devices are ESD protected; however, handling precautions are recommended. Human body model, 1.5k $\Omega$  in series with 100pF.
- Note 7.** All limits guaranteed by testing or statistical analysis.
- Note 8.** Continuous short circuit may exceed absolute maximum  $T_J$  under some conditions.
- Note 9.** CMRR is determined as follows: The maximum  $\Delta V_{OS}$  over the  $V_{CM}$  range is divided by the magnitude of the  $V_{CM}$  range. The measurement points are:  $V_{CM} = V_{V-} - 0.3V$ ,  $(V_{V+} - V_{V-})/2$ , and  $V_{V+} + 0.3V$ .
- Note 10.**  $R_L$  connected to 7.5V. Sourcing:  $7.5V \leq V_{OUT} \leq 12.5V$ . Sinking:  $2.5V \leq V_{OUT} \leq 7.5V$ .
- Note 11.** Device connected as a voltage follower with a 10V step input. The value is the positive or negative slew rate, whichever is slower.
- Note 12.** Referenced to input.

## Application Information

### Input Common-Mode Voltage

The MIC7122 tolerates input overdrive by at least 300mV beyond either rail without producing phase inversion.

If the absolute maximum input voltage is exceeded, the input current should be limited to  $\pm 5\text{mA}$  maximum to prevent reducing reliability. A  $10\text{k}\Omega$  series input resistor, used as a current limiter, will protect the input structure from voltages as large as  $50\text{V}$  above the supply or below ground. See Figure 1.

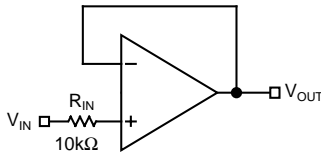


Figure 1. Input Current-Limit Protection

### Output Voltage Swing

Sink and source output resistances of the MIC7122 are equal. Maximum output voltage swing is determined by the load and the approximate output resistance. The output resistance is:

$$R_{\text{OUT}} = \frac{V_{\text{DROP}}}{I_{\text{LOAD}}}$$

$V_{\text{DROP}}$  is the voltage dropped within the amplifier output stage.  $V_{\text{DROP}}$  and  $I_{\text{LOAD}}$  can be determined from the  $V_{\text{O}}$  (output swing) portion of the appropriate Electrical Characteristics table.  $I_{\text{LOAD}}$  is equal to the typical output high voltage minus  $V_{+}/2$  and divided by  $R_{\text{LOAD}}$ . For example, using the Electrical Characteristics DC (5V) table, the typical output high voltage drops  $13\text{mV}$  using a  $2\text{k}\Omega$  load (connected to  $V_{+}/2$ ), which produces an  $I_{\text{LOAD}}$  of:

$$\frac{5.0\text{V} - 0.013\text{V} - 2.5\text{V}}{2\text{k}\Omega} = 1.244\text{mA}$$

Because of output stage symmetry, the corresponding typical output low voltage ( $13\text{mV}$ ) also equals  $V_{\text{DROP}}$ . Then:

$$R_{\text{OUT}} = \frac{0.013\text{V}}{0.001244\text{A}} = 10.5\Omega$$

### Power Dissipation

The MIC7122 output drive capability requires considering power dissipation. If the load impedance is low, it is possible to damage the device by exceeding the  $125^{\circ}\text{C}$  junction temperature rating.

On-chip power consists of two components: supply power and output stage power. Supply power ( $P_{\text{S}}$ ) is the product of the supply voltage ( $V_{\text{S}} = V_{\text{V}+} - V_{\text{V}-}$ ) and supply current ( $I_{\text{S}}$ ). Output stage power ( $P_{\text{O}}$ ) is the product of the output stage

voltage drop ( $V_{\text{DROP}}$ ) and the output (load) current ( $I_{\text{OUT}}$ ). Total on-chip power dissipation is:

$$P_{\text{D}} = P_{\text{S}} + P_{\text{O}}$$

$$P_{\text{D}} = V_{\text{S}} I_{\text{S}} + V_{\text{DROP}} I_{\text{OUT}}$$

where:

$P_{\text{D}}$  = total on-chip power

$P_{\text{S}}$  = supply power dissipation

$P_{\text{O}}$  = output power dissipation

$$V_{\text{S}} = V_{\text{V}+} - V_{\text{V}-}$$

$I_{\text{S}}$  = power supply current

$$V_{\text{DROP}} = V_{\text{V}+} - V_{\text{OUT}} \quad (\text{sourcing current})$$

$$V_{\text{DROP}} = V_{\text{OUT}} - V_{\text{V}-} \quad (\text{sinking current})$$

The above addresses only steady state (dc) conditions. For non-dc conditions the user must estimate power dissipation based on rms value of the signal.

The task is one of determining the allowable on-chip power dissipation for operation at a given ambient temperature and power supply voltage. From this determination, one may calculate the maximum allowable power dissipation and, after subtracting  $P_{\text{S}}$ , determine the maximum allowable load current, which in turn can be used to determine the minimum load impedance that may safely be driven. The calculation is summarized below.

$$P_{\text{D}(\text{max})} = \frac{T_{\text{J}(\text{max})} - T_{\text{A}}}{\theta_{\text{JA}}}$$

$$\theta_{\text{JA}(\text{MSOP-8})} = 200^{\circ}\text{C/W}$$

### Driving Capacitive Loads

Driving a capacitive load introduces phase-lag into the output signal, and this in turn reduces op-amp system phase margin. The application that is least forgiving of reduced phase margin is a unity gain amplifier. The MIC7122 can typically drive a  $200\text{pF}$  capacitive load connected directly to the output when configured as a unity-gain amplifier and powered with a  $2.2\text{V}$  supply. At  $15\text{V}$  operation the circuit typically drives  $500\text{pF}$ .

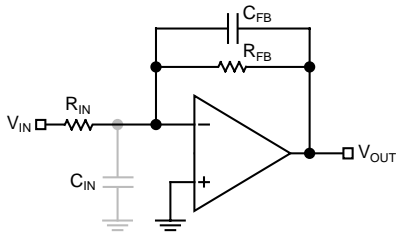
### Using Large-Value Feedback Resistors

A large-value feedback resistor ( $> 500\text{k}\Omega$ ) can reduce the phase margin of a system. This occurs when the feedback resistor acts in conjunction with input capacitance to create phase lag in the feedback signal. Input capacitance is usually a combination of input circuit components and other parasitic capacitance, such as amplifier input capacitance and stray printed circuit board capacitance.

Figure 2 illustrates a method of compensating phase lag caused by using a large-value feedback resistor. Feedback capacitor  $C_{\text{FB}}$  introduces sufficient phase lead to overcome the phase lag caused by feedback resistor  $R_{\text{FB}}$  and input

capacitance  $C_{IN}$ . The value of  $C_{FB}$  is determined by first estimating  $C_{IN}$  and then applying the following formula:

$$R_{IN} \times C_{IN} \leq R_{FB} \times C_{FB}$$

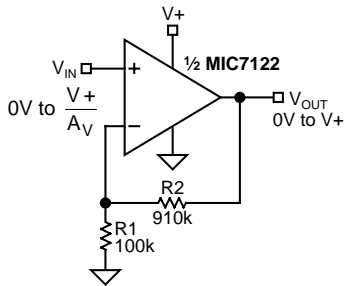


**Figure 2. Cancelling Feedback Phase Lag**

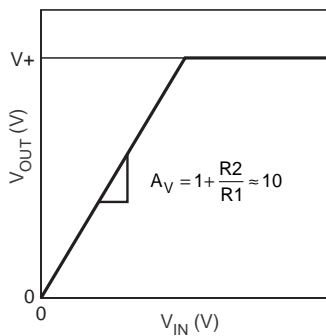
Since a significant percentage of  $C_{IN}$  may be caused by board layout, it is important to note that the correct value of  $C_{FB}$  may change when changing from a breadboard to the final circuit layout.

**Typical Circuits**

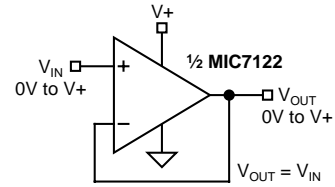
Some single-supply, rail-to-rail applications for which the MIC7122 is well suited are shown in the circuit diagrams of Figures 3 through 7.



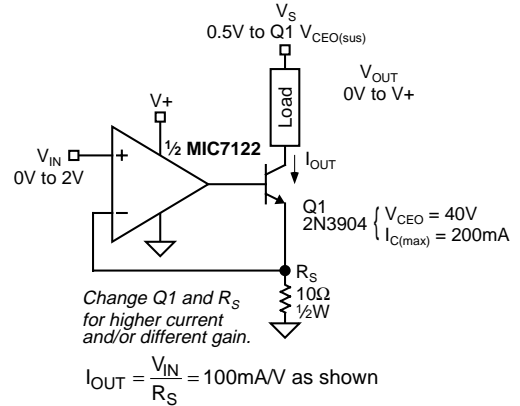
**Figure 3a. Noninverting Amplifier**



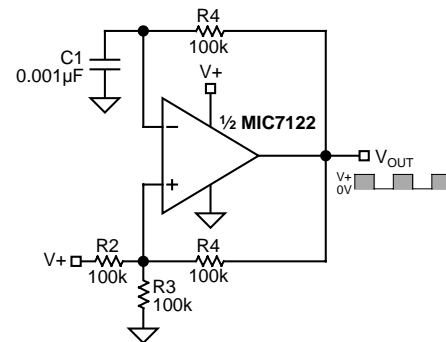
**Figure 3b. Noninverting Amplifier Behavior**



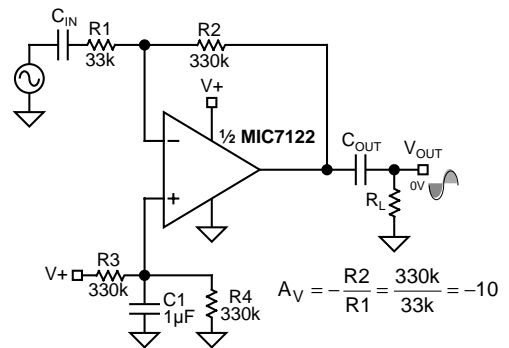
**Figure 4. Voltage Follower/Buffer**



**Figure 5. Voltage-Controlled Current Sink**

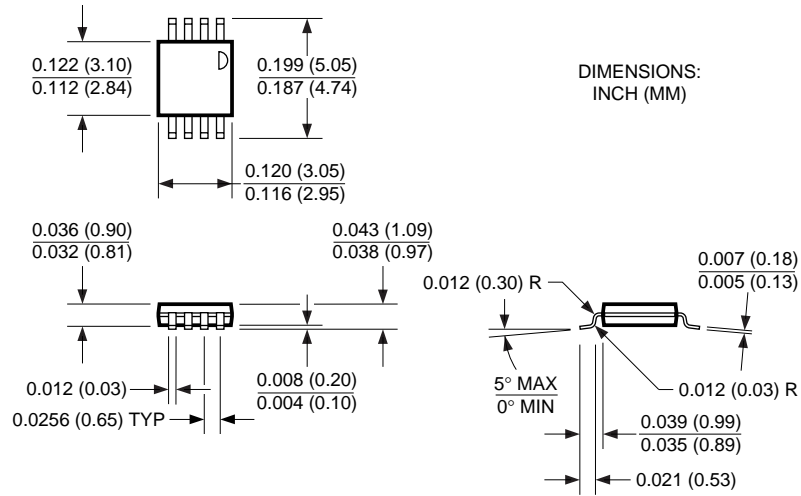


**Figure 6. Square Wave Oscillator**



**Figure 7. AC-Coupled Inverting Amplifier**

Package Information



**MM8™ 8-Lead MSOP (MM)**