



LT1252

Low Cost
Video Amplifier

FEATURES

- Low Cost
- Current Feedback Amplifier
- Differential Gain: 0.01%, $R_L = 150\Omega$, $V_S = \pm 5V$
- Differential Phase: 0.09°, $R_L = 150\Omega$, $V_S = \pm 5V$
- Flat to 30MHz, 0.1dB
- 100MHz Bandwidth on $\pm 5V$
- Wide Supply Range: $\pm 2V(4V)$ to $\pm 14V(28V)$
- Low Power: 85mW at $\pm 5V$

APPLICATIONS

- RGB Cable Drivers
- Composite Video Cable Drivers
- Gain Blocks in IF Stages

DESCRIPTION

The LT1252 is a low cost current feedback amplifier for video applications. The LT1252 is ideal for driving low impedance loads such as cables and filters. The wide bandwidth and high slew rate of this amplifier make driving RGB signals between PCs and workstations easy. The linearity of the LT1252 is outstanding; it is unsurpassed for driving composite video.

The LT1252 is available in the 8-pin DIP and the S8 surface mount package. For higher performance and shutdown operation, see the LT1227. For dual and quad amplifiers with similar performance see the LT1253/LT1254.

TYPICAL APPLICATION

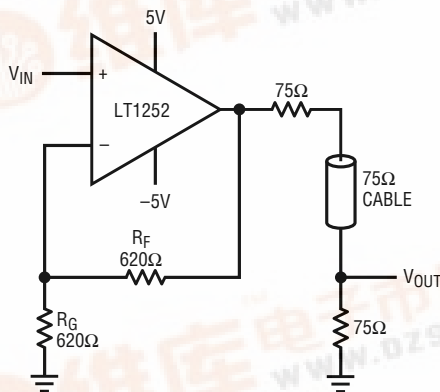

$A_V = 1 + \frac{R_F}{R_G}$ $BW = 100MHz$
AT AMPLIFIER OUTPUT.
6dB LESS AT V_{OUT} .

LT1252 • TA01

Transient Response

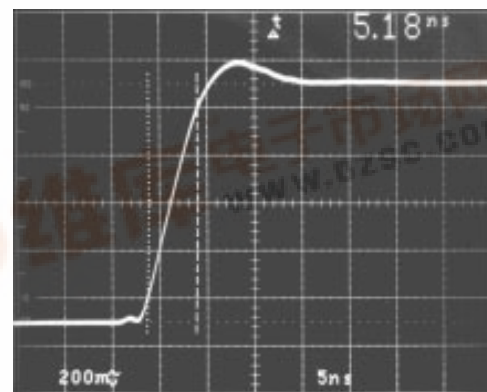

$V_S = \pm 5V$
 $A_V = 2$
 $R_L = 150\Omega$
 $V_O = 1V$

LT1252 • TA02

LT1252

ABSOLUTE MAXIMUM RATINGS

Total Supply Voltage (V^+ to V^-)	28V	Storage Temperature Range	-65°C to 150°C
Input Current	±15mA	Junction Temperature (Note 2)	150°C
Output Short-Circuit Duration (Note 1)	Continuous	Lead Temperature (Soldering, 10 sec)	300°C
Operating Temperature Range	0°C to 70°C		

PACKAGE/ORDER INFORMATION

<p>S8 PACKAGE 8-LEAD PLASTIC SO $T_{JMAX} = 150^{\circ}C, \theta_{JA} = 150^{\circ}C/W$</p>	ORDER PART NUMBER	<p>N8 PACKAGE 8-LEAD PLASTIC DIP $T_{JMAX} = 150^{\circ}C, \theta_{JA} = 100^{\circ}C/W$</p>	ORDER PART NUMBER
	LT1252CS8		LT1252CN8
	S8 PART MARKING		
	1252		

ELECTRICAL CHARACTERISTICS $0^{\circ}C \leq T_A \leq 70^{\circ}C, V_S = \pm 5V$ to $\pm 12V$, unless otherwise noted.

SYMBOL	PARAMETER	CONDITIONS	MIN	TYP	MAX	UNITS
V_{OS}	Input Offset Voltage			5	15	mV
$+I_B$	Noninverting Bias Current			1	15	μA
$-I_B$	Inverting Bias Current			20	100	μA
A_{VOL}	Large-Signal Voltage Gain	$V_S = \pm 5V, V_O = \pm 2V, R_L = 150\Omega$	560	1500		V/V
PSRR	Power Supply Rejection Ratio	$V_S = \pm 3V$ to $\pm 12V$	60	70		dB
CMRR	Common-Mode Rejection Ratio	$V_S = \pm 5V, V_{CM} = \pm 2V$	55	65		dB
V_{OUT}	Maximum Output Voltage Swing	$V_S = \pm 12V, R_L = 500\Omega$ $V_S = \pm 5V, R_L = 150\Omega$	±7.0 ±2.5	±10.5 ±3.7		V V
I_{OUT}	Maximum Output Current		30	55		mA
I_S	Supply Current			8.5	18	mA
R_{IN}	Input Resistance		1	10		M Ω
C_{IN}	Input Capacitance			3		pF
	Power Supply Range	Dual Single	±2 4		±12 24	V V
SR	Input Slew Rate	$A_V = 1$		125		V/ μs
	Output Slew Rate	$A_V = 2$		250		V/ μs

ELECTRICAL CHARACTERISTICS $0^{\circ}\text{C} \leq T_A \leq 70^{\circ}\text{C}$, $V_S = \pm 5\text{V}$ to $\pm 12\text{V}$, unless otherwise noted.

SYMBOL	PARAMETER	CONDITIONS	MIN	TYP	MAX	UNITS
t_r	Small-Signal Rise Time	$V_S = \pm 12\text{V}$, $A_V = 2$		3.5		ns
	Rise and Fall Time	$V_S = \pm 5\text{V}$, $A_V = 2$, $V_{OUT} = 1V_{P-P}$		5.2		ns
t_p	Propagation Delay	$V_S = \pm 5\text{V}$, $A_V = 2$		3.5		ns

Note 1: A heat sink may be required to keep the junction temperature below absolute maximum when the output is shorted indefinitely.

LT1252CN8: $T_J = T_A + (P_D \times 100^{\circ}\text{C}/\text{W})$

LT1252CS8: $T_J = T_A + (P_D \times 150^{\circ}\text{C}/\text{W})$

Note 2: T_J is calculated from the ambient temperature T_A and power dissipation P_D according to the following formulas:

TYPICAL AC PERFORMANCE

BANDWIDTH

V_S	A_V	R_L	R_F	R_G	SMALL SIGNAL –3dB BW (MHz)	SMALL SIGNAL –0.1dB BW (MHz)	SMALL SIGNAL PEAKING (dB)
±12	1	150	2370	None	282	45	1.9
±12	–1	1000	1100	1100	58	17	0.1
±12	–1	150	909	909	73	34	0.1
±12	2	1000	1210	1210	253	20	0.1
±12	2	150	909	909	142	38	0.1
±12	5	1000	1000	249	73	25	0.1
±12	5	150	866	215	75	31	0.1
±12	10	1000	909	100	67	26	0.1
±12	10	150	768	84.5	69	32	0.1
±5	1	1000	2210	None	260	10	2.4
±5	1	150	1300	None	232	50	0.8
±5	–1	1000	1000	1000	50	11	0.1
±5	–1	150	732	732	69	34	0.1
±5	2	1000	909	909	133	24	0.1
±5	2	150	787	787	100	30	0.1
±5	5	1000	825	205	62	21	0.1
±5	5	150	698	174	66	30	0.1
±5	10	1000	750	82.5	58	22	0.1
±5	10	150	619	68.1	60	30	0.1

NTSC VIDEO (Note 1)

V_S	A_V	R_L	R_F	R_G	DIFFERENTIAL GAIN	DIFFERENTIAL PHASE
±12	2	1000	1000	1000	0.02%	0.02°
±12	2	150	1000	1000	0.03%	0.04°
±5	2	1000	1000	1000	0.02%	0.08°
±5	2	150	1000	1000	0.01%	0.09°

Note 1: Differential Gain and Phase are measured using a Tektronix TSG 120 YC/NTSC signal generator and a Tektronix 1780R Video Measurement Set. The resolution of this equipment is 0.1% and 0.1°. Ten identical

amplifier stages were cascaded giving an effective resolution of 0.01% and 0.01°.

LT1252

TYPICAL PERFORMANCE CHARACTERISTICS

Supply Current vs Supply Voltage

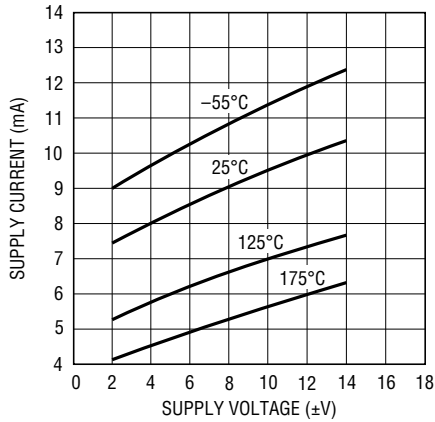

LT1252 • TPC01

Input Common-Mode Limit vs Temperature

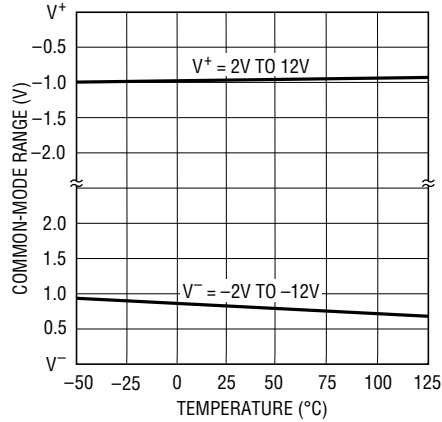

LT1252 • TPC02

Output Saturation Voltage vs Temperature

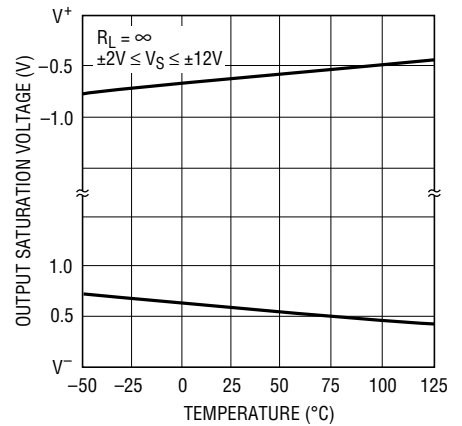

LT1252 • TPC03

Settling Time to 10mV vs Output Step

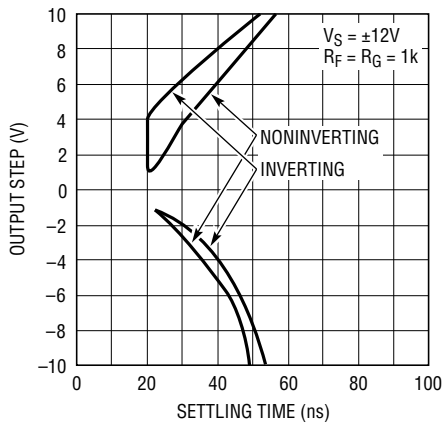

LT1252 • TPC04

2nd and 3rd Harmonic Distortion vs Frequency

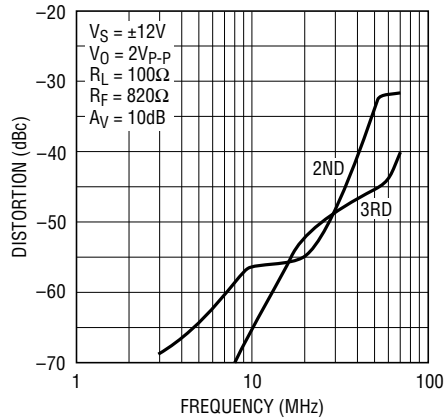

LT1252 • TPC05

Power Supply Rejection vs Frequency

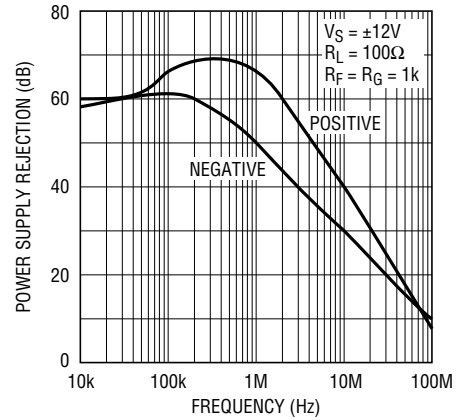

LT1252 • TPC06

Spot Noise Voltage and Current vs Frequency

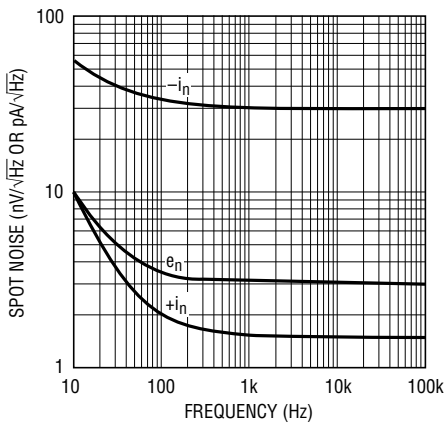

LT1252 • TPC07

Output Impedance vs Frequency

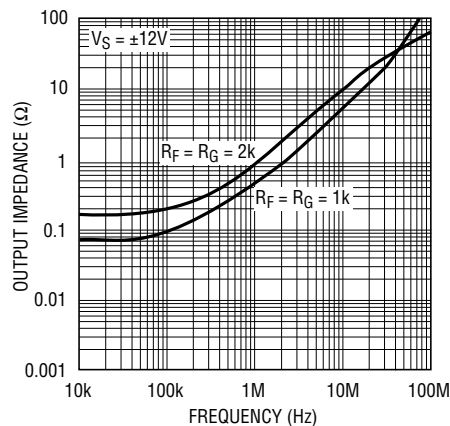

LT1252 • TPC08

Output Short-Circuit Current vs Junction Temperature

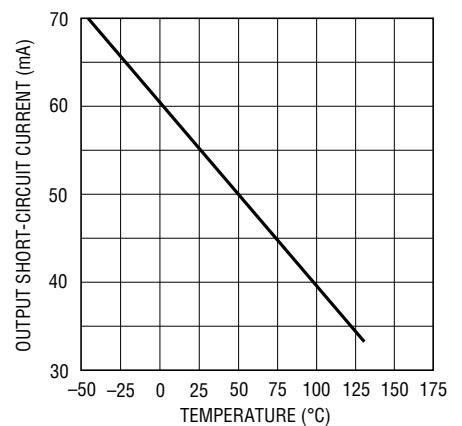

LT1252 • TPC09

TYPICAL PERFORMANCE CHARACTERISTICS

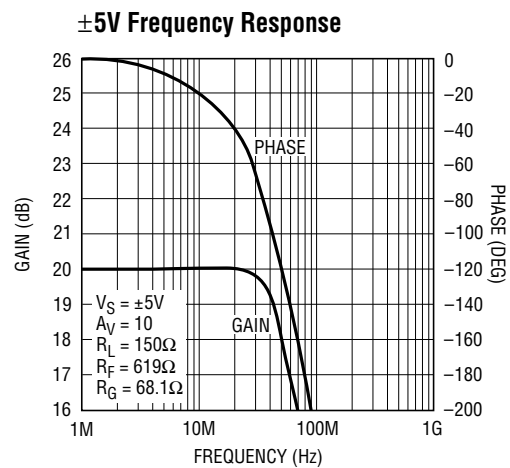
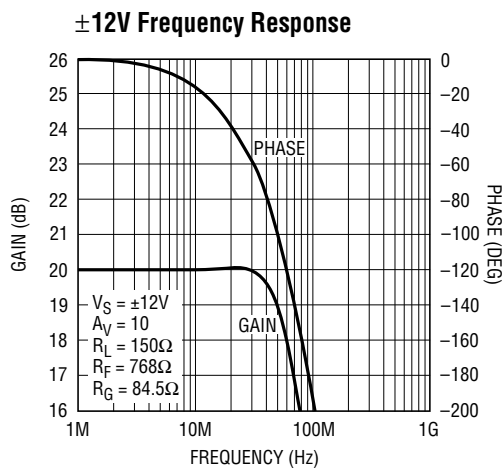
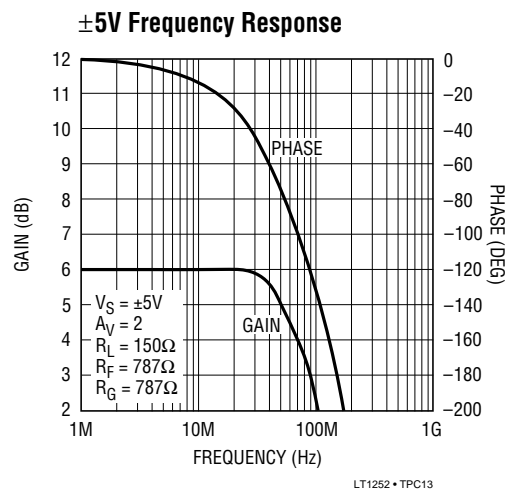
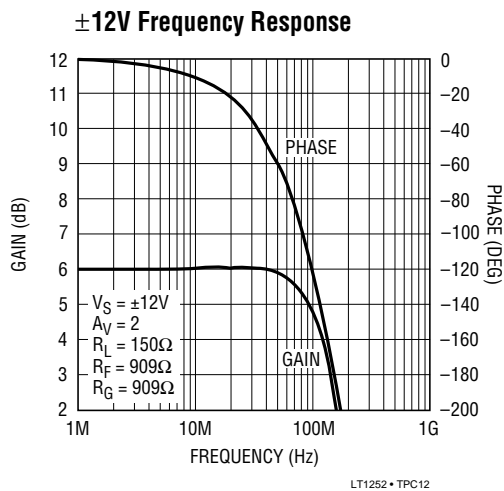
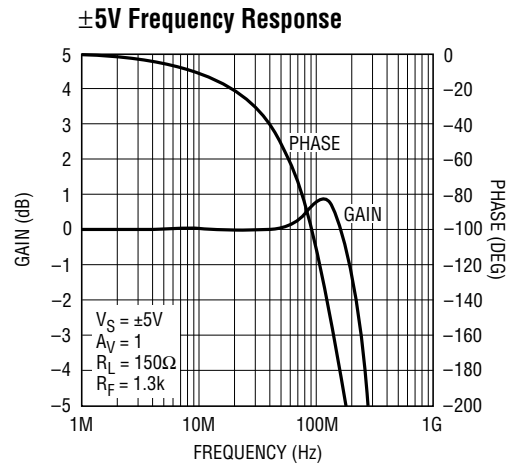
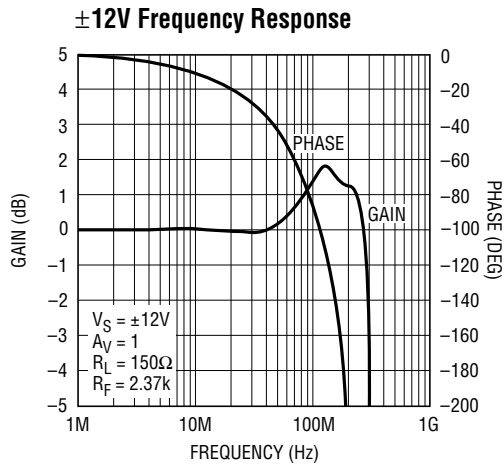

LT1252

TYPICAL PERFORMANCE CHARACTERISTICS

Transient Response

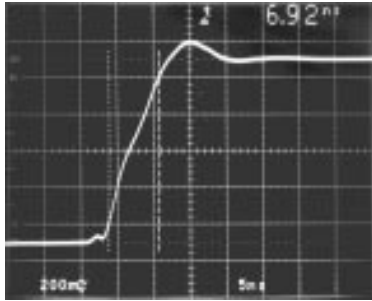

$V_S = \pm 5V$
 $A_V = 1$
 $R_L = 150\Omega$
 $R_F = 619\Omega$
 $V_0 = 1V$

LT1252 • TPC16

Transient Response

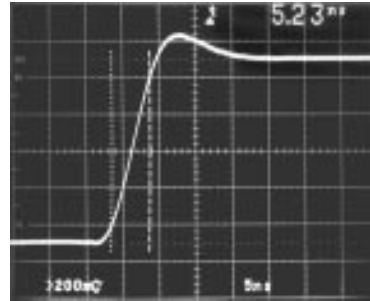

$V_S = \pm 5V$ $R_F = 619\Omega$
 $A_V = 10$ $R_G = 68.1\Omega$
 $R_L = 150\Omega$ $V_0 = 1.5V$

LT1252 • TPC17

TYPICAL APPLICATIONS

Single Supply AC-Coupled Amplifier
Noninverting

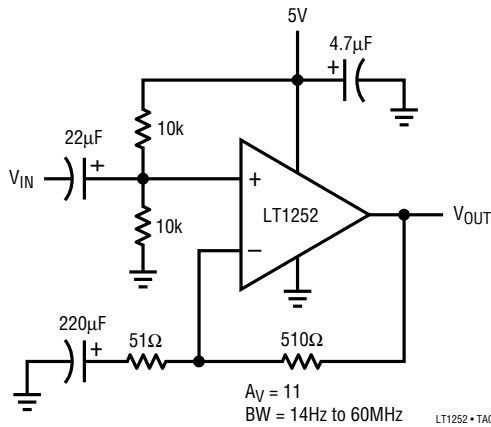

Single Supply AC-Coupled Amplifier
Inverting

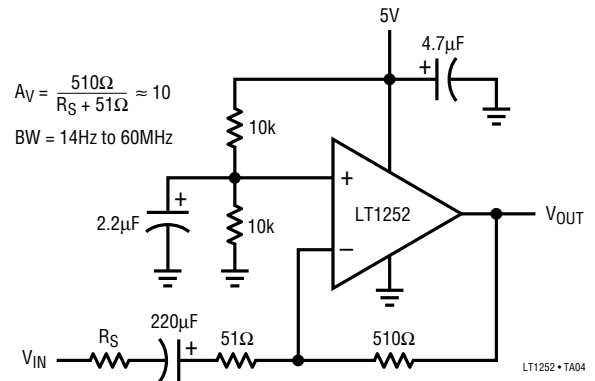

Half Wave Rectifier

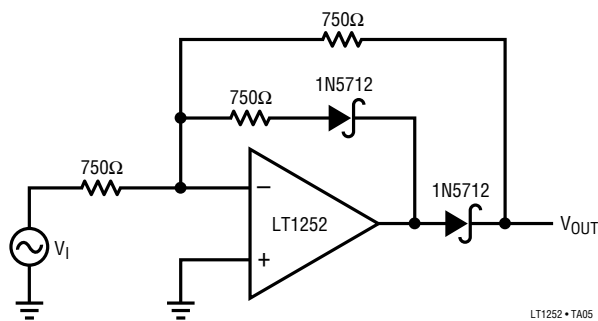

SIMPLIFIED SCHEMATIC

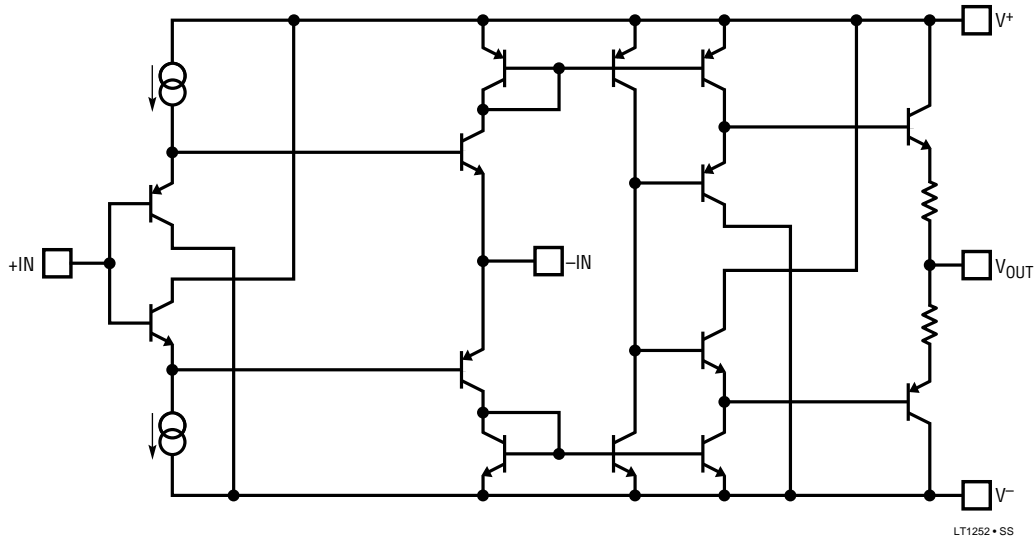

PACKAGE DESCRIPTION

Dimensions in inches (millimeters) unless otherwise noted.

N8 Package 8-Lead Plastic DIP

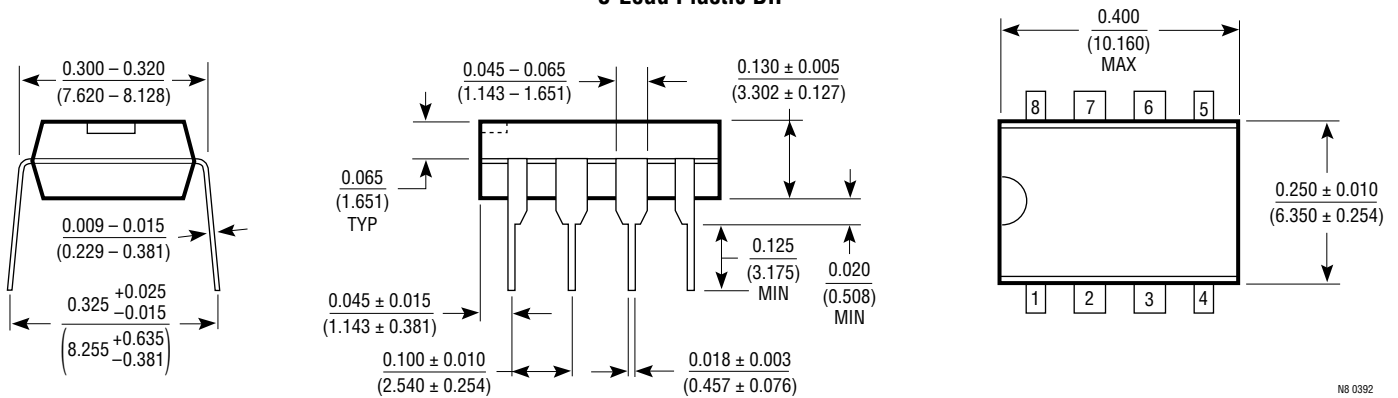

S8 Package 8-Lead Plastic SOIC

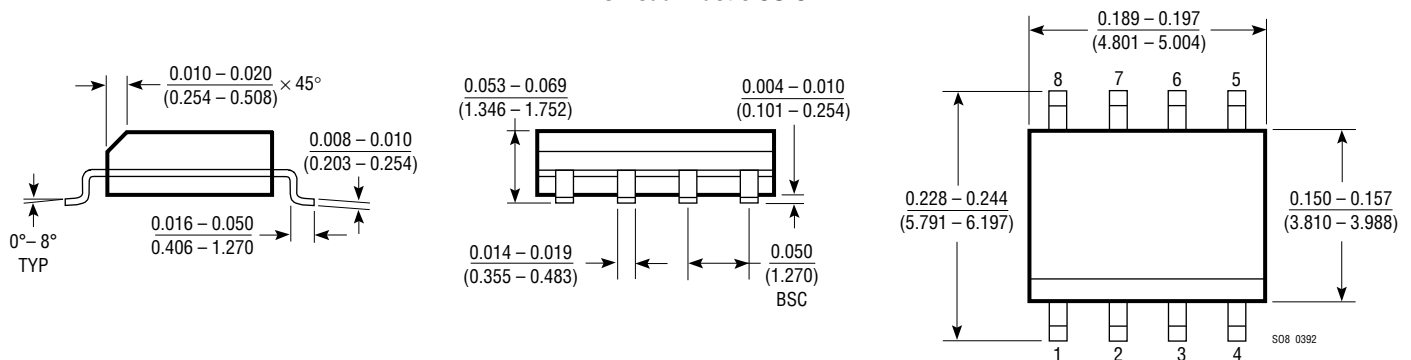

U.S. Area Sales Offices

NORTHEAST REGION

Linear Technology Corporation
One Oxford Valley
2300 E. Lincoln Hwy., Suite 306
Langhorne, PA 19047
Phone: (215) 757-8578
FAX: (215) 757-5631

Linear Technology Corporation

266 Lowell St., Suite B-8
Wilmington, MA 01887
Phone: (508) 658-3881
FAX: (508) 658-2701

SOUTHEAST REGION

Linear Technology Corporation
17060 Dallas Parkway
Suite 208
Dallas, TX 75248
Phone: (214) 733-3071
FAX: (214) 380-5138

CENTRAL REGION

Linear Technology Corporation
Chesapeake Square
229 Mitchell Court, Suite A-25
Addison, IL 60101
Phone: (708) 620-6910
FAX: (708) 620-6977

SOUTHWEST REGION

Linear Technology Corporation
22141 Ventura Blvd.
Suite 206
Woodland Hills, CA 91364
Phone: (818) 703-0835
FAX: (818) 703-0517

NORTHWEST REGION

Linear Technology Corporation
782 Sycamore Dr.
Milpitas, CA 95035
Phone: (408) 428-2050
FAX: (408) 432-6331

International Sales Offices

FRANCE

Linear Technology S.A.R.L.
Immeuble "Le Quartz"
58 Chemin de la Justice
92290 Chatenay Malabry
France
Phone: 33-1-41079555
FAX: 33-1-46314613

KOREA

Linear Technology Korea Branch
Namsong Building, #505
Itaewon-Dong 260-199
Yongsan-Ku, Seoul
Korea
Phone: 82-2-792-1617
FAX: 82-2-792-1619

TAIWAN

Linear Technology Corporation
Rm. 801, No. 46, Sec. 2
Chung Shan N. Rd.
Taipei, Taiwan, R.O.C.
Phone: 886-2-521-7575
FAX: 886-2-562-2285

GERMANY

Linear Technolgy GmbH
Untere Hauptstr. 9
D-85386 Eching
Germany
Phone: 49-89-3197410
FAX: 49-89-3194821

SINGAPORE

Linear Technology Pte. Ltd.
101 Boon Keng Road
#02-15 Kallang Ind. Estates
Singapore 1233
Phone: 65-293-5322
FAX: 65-292-0398

UNITED KINGDOM

Linear Technology (UK) Ltd.
The Coliseum, Riverside Way
Camberley, Surrey GU15 3YL
United Kingdom
Phone: 44-276-677676
FAX: 44-276-64851

JAPAN

Linear Technology KK
5F YZ Bldg.
4-4-12 Iidabashi, Chiyoda-Ku
Tokyo, 102 Japan
Phone: 81-3-3237-7891
FAX: 81-3-3237-8010

World Headquarters

Linear Technology Corporation
1630 McCarthy Blvd.
Milpitas, CA 95035-7487
Phone: (408) 432-1900
FAX: (408) 434-0507