

# MC33232

## Power Factor Controller

The MC33232 is the monolithic Integrated Circuit using the SMARTMOS<sup>®</sup> process as the new technology. And is active power factor controller specially design for use as off-line power converter application. This integrated circuit features an internal startup timer for stand-alone application, a one quadrant multiplier for near unity power factor, zero current detector to ensure critical condition operation, transconductance error amplifier, quickstart circuit for enhanced startup, trimmed internal bandgap reference, current sensing comparator, a totem pole output ideally suited for drive a power MOSFET, and a one shot-rigger circuit to eliminate a problem at the light loading.

Also included are protective features consisting of an overvoltage comparator to eliminate runaway output voltage due to removal, and a protect circuit to eliminate thermal runaway. This device is available in dual-in-line and surface mount plastic package.

### Features

- One Shot-trigger Circuit to Eliminate a Problem at the Light Loading
- Overvoltage Comparator Eliminates Runaway Output Voltage
- Quickstart Circuit for Enhanced Startup
- Internal Startup Timer
- One Quadrant Multiplier
- Zero Current Detector
- Trimmed 2% Internal Bandgap Reference
- Totem Pole Output with High State Clamp
- Undervoltage Lockout with 6.0 V of Hysteresis
- Low Startup and Operating Current
- Pb-Free Packages are Available



**ON Semiconductor<sup>®</sup>**

<http://onsemi.com>

## SILICON MONOLITHIC INTEGRATED CIRCUIT

### MARKING DIAGRAMS

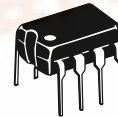

**PDIP-8  
P SUFFIX  
CASE 626**

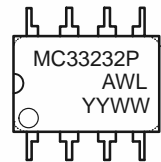

**SOIC-8  
D SUFFIX  
CASE 751**

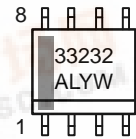

A = Assembly Location  
WL or L = Wafer Lot  
Y = Year  
WW or W = Work Week

### PIN ASSIGNMENT

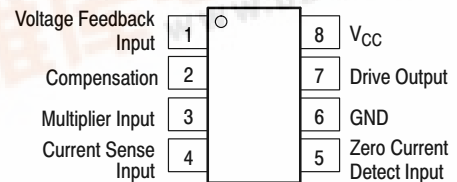

### ORDERING INFORMATION

See detailed ordering and shipping information in the package dimensions section on page 2 of this data sheet.



# MC33232

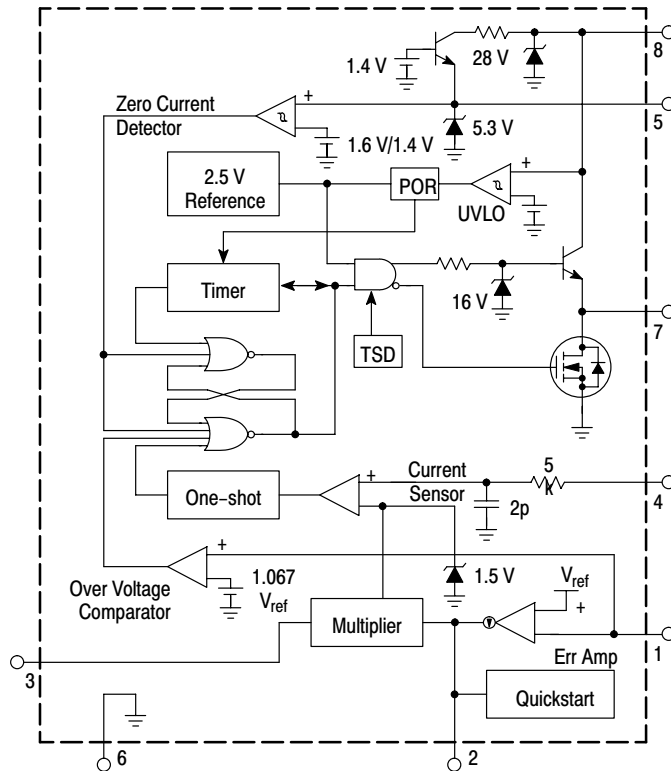

Figure 1. Simplified Block Diagram

## ORDERING INFORMATION

Device	Operating Junction Temperature Range	Package	Shipping†
MC33232P	-40°C to +150°C	PDIP-8	50 Units / Rail
MC33232PG		PDIP-8 (Pb-Free)	50 Units / Rail
MC33232D		SOIC-8	98 Units / Rail
MC33232DG		SOIC-8 (Pb-Free)	98 Units / Rail
MC33232DR2		SOIC-8	2500 Tape & Reel
MC33232DR2G		SOIC-8 (Pb-Free)	2500 Tape & Reel

†For information on tape and reel specifications, including part orientation and tape sizes, please refer to our Tape and Reel Packaging Specifications Brochure, BRD8011/D.

# MC33232

## MAXIMUM RATINGS

Parameter	Symbol	Value	Unit
Total Power Supply and Zener Current	$(I_{CC} + I_Z)$	30	mA
Output Current, Source or Sink (Note 1) Peak Current (Under 0.5 $\mu$ sec) DC (Continuously Current)	$I_O$	750 300	mA
Current Sense, Multiplier and Voltage Feedback Input	$V_{in}$	-0.3 to 10	V
Zero Current Detect Input High State Forward Current Low State Reverse Current	$I_{in}$	50 -10	mA
Power Dissipation and Thermal Characteristic D Suffix, Plastic Package, Case 626 Maximum Power Dissipation @ $T_A = 70^\circ\text{C}$ Thermal Resistance, Junction-to-Air P Suffix, Plastic Package, Case 626 Maximum Power Dissipation @ $T_A = 70^\circ\text{C}$ Thermal Resistance, Junction-to-Air	$P_D$ $R_{\theta JA}$ $P_D$ $R_{\theta JA}$	450 178 800 100	mW $^\circ\text{C/W}$ mW $^\circ\text{C/W}$
Operating Junction Temperature	$T_J$	+150	$^\circ\text{C}$
Storage Temperature	$T_{stg}$	-55 to +150	$^\circ\text{C}$

Maximum ratings are those values beyond which device damage can occur. Maximum ratings applied to the device are individual stress limit values (not normal operating conditions) and are not valid simultaneously. If these limits are exceeded, device functional operation is not implied, damage may occur and reliability may be affected.

1. Maximum package power dissipation limits must be observed.

## RECOMMENDED OPERATING CONDITION ( $V_{CC} = 12\text{ V}$ and $T_A = 25^\circ\text{C}$ unless otherwise noted)

Characteristic	Symbol	Min	Typ	Max	Unit
Operating Frequency ( $R_{ZCD} = 4.7\text{ k}\Omega$ , $C_{err} = 0.68\text{ }\mu\text{F}$ ) Normal Loading Under Loading	F		0.4 1.0		MHz
External Resistance for Zero Current Detect Control	$R_{ZCD}$	-	4.7	-	k $\Omega$
Operating Ambient Temperature	$T_A$	-20	-	+85	$^\circ\text{C}$

## ELECTRICAL CHARACTERISTICS ( $V_{CC} = 12\text{ V}$ , for typical values $T_A = -20^\circ\text{C} \sim +85^\circ\text{C}$ , unless otherwise noted)

Characteristic	Symbol	Min	Typ	Max	Unit
----------------	--------	-----	-----	-----	------

### ERROR AMPLIFIER

Voltage Feedback Input Threshold $T_A = 25^\circ\text{C}$ $T_A = -20^\circ\text{C} \sim +85^\circ\text{C}$ ( $V_{CC} = 12\text{ V} \sim 25\text{ V}$ )	$V_{FB}$	2.465 2.44	2.5 -	2.535 2.54	V
Line Regulation ( $V_{CC} = 12\text{ V} \sim 25\text{ V}$ , $T_A = 25^\circ\text{C}$ )	$\text{Reg}_{line}$	-	1.0	10	mV
Input Bias Current ( $V_{FB} = 0\text{ V}$ )	$I_{IB}$	-	-0.1	-0.5	$\mu\text{A}$
Transconductance ( $T_A = 25^\circ\text{C}$ )	gm	80	100	130	$\mu\text{mho}$
Output Current ( $V_{CC} = 12\text{ V} \sim 28\text{ V}$ , $T_A = 25^\circ\text{C}$ ) Source ( $V_{FB} = 2.3\text{ V}$ ) Sink ( $V_{FB} = 2.7\text{ V}$ )	$I_{source}$ $I_{sink}$	- -	10 10	- -	$\mu\text{A}$
Output Voltage Swing High State ( $V_{FB} = 2.3\text{ V}$ ) Low State ( $V_{FB} = 2.7\text{ V}$ )	$V_{OH(ea)}$ $V_{OL(ea)}$	5.8 -	6.2 1.7	- 2.4	V

### OVERVOLTAGE COMPARATOR

Voltage Feedback Input Threshold	$V_{TH}$	1.04 $V_{FB}$	1.067 $V_{FB}$	1.095 $V_{FB}$	V
----------------------------------	----------	---------------	----------------	----------------	---

### OVERTEMPERATURE PROTECT CIRCUIT (This item is just reference value without any specifying)

Detect Temperature	TSD	120	-	-	$^\circ\text{C}$
--------------------	-----	-----	---	---	------------------

# MC33232

## ELECTRICAL CHARACTERISTICS ( $V_{CC} = 12\text{ V}$ , for typical values $T_A = -20^\circ\text{C} \sim +85^\circ\text{C}$ , unless otherwise noted)

Characteristic	Symbol	Min	Typ	Max	Unit
<b>MULTIPLIER</b>					
Input Threshold (Pin 2)	$V_{thm}$	1.05 $V_{OL}$ (ea)	1.2 $V_{OL}$ (ea)	–	V
Dynamic Input Voltage Range					V
Multiplier Input (Pin 3)	Vpin 3	0 to 2.5	0 to 3.5	–	
Compensation (Pin 2)	Vpin 2	$V_{thm}$ to $V_{thm} + 1.0$	$V_{thm}$ to $V_{thm} + 1.5$	–	
Input Bias Current, Pin 3 ( $V_{FB} = 0\text{ V}$ )	$I_{B(mult)}$	–	–0.1	–0.5	$\mu\text{A}$
Multiplier Gain (Vpin 3 = 0.5 V, Vpin 2 = $V_{FB} + 1.0\text{ V}$ )	K	0.43	0.65	0.87	1/V

## ZERO CURRENT DETECTOR

Input Threshold Voltage ( $V_{in}$ Increasing)	$V_{th(ZCD)}$	1.33	1.6	1.87	V
Hysteresis ( $V_{in}$ Decreasing)	$V_{H(ZCD)}$	100	200	300	mV
Input Clamp Voltage High State ( $I_{DET} = +3.0\text{ mA}$ )	$V_{IH}$	5.0	5.3	–	V
Low State ( $I_{DET} = -3.0\text{ mA}$ )	$V_{IL}$	0.3	0.7	1.0	
Propagation Delay Time Zero Current Detect to Drive Out $R_{ZCD} = 4.7\text{ k}\Omega$	TZO	–	100	200	nsec

## ONE SHOT TRIGGER

Output Minimum Off Time	$T_{OS}$	500	–	850	nsec
-------------------------	----------	-----	---	-----	------

## CURRENT SENSE COMPARATOR

Input Bias Current (Vpin 4 = 0 V)	$I_{B(cs)}$	–	–0.15	–1.0	$\mu\text{A}$
Input Offset Voltage (Vpin 2 = 1.1 V, Vpin 3 = 0 V)	$V_{io(cs)}$	–	9.0	25	mV
Maximum Current Sense Input Threshold	$V_{thmax}$	1.3	1.5	1.8	V
Delay to Output	$t_{PHL(in/out)}$	–	100	200	nsec

## DRIVE OUTPUT

Output Voltage ( $V_{CC} = 12\text{ V}$ )					V
Low State ( $I_{sink} = 20\text{ mA}$ )	$V_{OL}$	–	0.3	0.8	
( $I_{sink} = 200\text{ mA}$ )		–	2.4	3.3	
High State ( $I_{source} = 20\text{ mA}$ )	$V_{OH}$	9.8	10.3	–	V
( $I_{source} = 200\text{ mA}$ )		7.8	8.4	–	
Output Voltage ( $V_{CC} = 25\text{ V}$ , $I_{source} = 20\text{ mA}$ , $C_L = 15\text{ pF}$ )	$V_O$	14	16	18	V
Output Voltage Rise Time ( $C_L = 1.0\text{ nF}$ )	$t_r$	–	50	120	nsec
Output Voltage Fall Time ( $C_L = 1.0\text{ nF}$ )	$t_f$	–	50	120	nsec
Output Voltage with UVLO Active ( $V_{CC} = 7.0\text{ V}$ , $I_{sink} = 1.0\text{ mA}$ )	$V_{O(UVLO)}$	–	0.1	0.5	V

## RESTART TIMER

Restart Time Delay	tDLY	200	900	–	$\mu\text{sec}$
Restart Time at Startup	POR	0	25	–	$\mu\text{sec}$

## UNDER VOLTAGE LOCKOUT (Metal Option Version)

Startup Threshold ( $V_{CC}$ Increasing)	$V_{th(on)}$	14.4	16	17.6	V
Minimum Operating Voltage After Turn-off ( $V_{CC}$ Decreasing)	$V_{shut}$	9.0	10	11	V
Hysteresis	$V_H$	3.5	6.0	8.6	V

## TOTAL DEVICE

Power Supply Current Startup ( $V_{CC} = 7.0\text{ V}$ )	$I_{CC}$	–	0.05	0.1	mA
Operating		–	6.5	12	
Dynamic Operating (50 KHz, $C_L = 1.0\text{ nF}$ )		–	9.0	20	
Power Supply Zener Voltage ( $I_{CC} = 25\text{ mA}$ )	VZ	26	28	–	V

# MC33232

**MEASUREMENT CONDITION** Note: Test conditions follow the test circuit diagram unless otherwise noted (See last page)

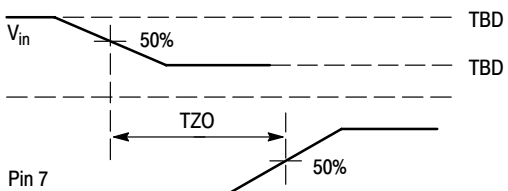
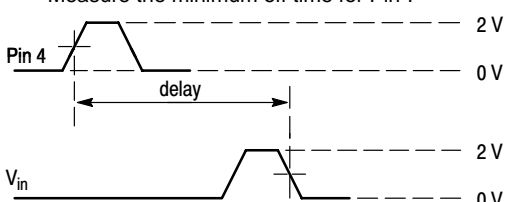
Item	Condition		Measurement Method
V <sub>FB</sub>		Pin 1 = Pin 2	Measure Pin 1 voltage when connect Pin 1 and Pin 2
V <sub>FB2</sub>	SW1 = B		
Regline			Regline = V <sub>FB2</sub> - V <sub>FB</sub>
I <sub>B(err)</sub>	Pin 1 = 0 V		Measure Pin 1 current
gm	Pin 2 = 2.0 V Pin 2 current (I <sub>pin2</sub> ) @ Pin 1 = 2.55 Pin 2 current (I <sub>pin2</sub> ) @ Pin 1 = 2.45		$gm = \frac{(I_{pin2} - I'_{pin2})}{(2.55 - 2.45)}$
I <sub>source</sub>	Pin 1 = 2.3 V	SW1 = A&B Pin 2 = 2.0 V	Measure Pin 2 output current
I <sub>sink</sub>	Pin 1 = 2.7 V		
V <sub>OH(ea)</sub>	Pin 1 = 2.3 V		Measure Pin 2 voltage
V <sub>OL(ea)</sub>	Pin 1 = 2.7 V		
V <sub>th</sub>	V <sub>in</sub> = Ref.1 Pin 4 = GND	Pin 2 = 4.0 V Pin 3 = 2.0 V	Measure Pin 1 voltage when Pin 7 switch to low by increasing Pin 1 voltage from 0 V
V <sub>th(mult)</sub>	V <sub>in</sub> = Ref.1 Pin 1 = 0 V	Pin 4 = 0.015 V Pin 3 = 0.5 V	Measure Pin 2 voltage when Pin 7 switch to low by decreasing Pin 2 voltage from 2.5 V
V <sub>pin3</sub>	V <sub>in</sub> = Ref.1 Pin 2 = V <sub>th(mult)</sub>  Measure Pin 4 voltage when Pin 7 switch to low with each Pin 3 condition  A: @ Pin 3 = 0 V B: @ Pin 3 = 1.25 V C: @ Pin 3 = 2.5 V		$\alpha = \frac{C}{A} \times \frac{0.77}{1.67} + A$  $25\% \cdot \left  \frac{B - \alpha}{C - A} \right  \times 100$  Measure the A, B and C with the condition and calculate the linearity of the multiplier
I <sub>B(mult)</sub>	Pin 1, 3 = 0 V	Pin 2 = 1.1 V	Measure Pin 3 current
K	Pin 1 = 0 V  Pin 2 = V <sub>th(mult)</sub> + 1 V	Pin 3 = 0.5 V  V <sub>in</sub> = Ref.1	Measure V <sub>thp4</sub> as Pin 4 voltage when Pin 7 switch to low by increasing Pin 4 voltage from 0 V and calculate by the following equation.  $K = V_{thp4} / 0.50$
V <sub>th(ZCD)</sub>	V <sub>in</sub> = Ref.1	Pin 1 = 0 V  Pin 2 = 3.0 V  Pin 3 = 0.5 V  Pin 4 = GND	Measure Pin 5 voltage when Pin 7 switch to low by increasing V <sub>in</sub> voltage from 0 V
V <sub>H</sub>			Measure V <sub>th2</sub> as Pin 5 voltage when Pin 7 switch to low by increasing V <sub>in</sub> voltage from 4 V and calculate V <sub>H</sub> by the following equation.  $V_H = V_{th(zero)} - V_{th2}$
TZO	SW3 = ON		
TZO2	SW2 = B		Measure the propagation delay time from V <sub>in</sub> to Pin 7  
TOS	V <sub>in</sub> = Ref.1  Pin 3 = 0.5 V  Delay: 500 nSec ~ 700 nSec	Pin 1 = 0 V	Measure the minimum off time for Pin 7  

Ref.1: Pin 4 = GND, V<sub>in</sub> = 4 V return to zero pulse

# MC33232

## MEASUREMENT CONDITION

Item	Condition		Measurement Method
$V_{IH(ZCD)}$	Pin 1 = 0 V	Pin 5 = 3 mA	Measure Pin 5 voltage at 3 mA to Pin 5
$V_{IL(ZCD)}$	Pin 2 = 1.1 V	Pin 5 = -3 mA	Measure Pin 5 voltage at -3 mA to Pin 5
$I_{B(CS)}$		Pin 4 = 0 V	Measure Pin 4 current
$V_{IO(CS)}$		Pin 3 = 0 V $V_{in} = \text{Ref.1}$	Measure Pin 4 voltage when Pin 7 switch to low by increasing Pin 4 voltage from -0.3 V
$t_{PHL}$	Pin 1 = 0 V Pin 2 = $V_{th(mult)} + 0.5 \text{ V}$ Pin 3 = 0.5 V Pin 4 = See right figure $V_{in} = \text{Ref.1}$ $V_{th(cs)}$ : Threshold voltage of Pin 4 (at Pin 2 = $V_{th(mult)} + 0.5 \text{ V}$ , Pin 3 = 0.5 V)		
$V_{th(max)}$	Pin 1 = 0 V Pin 2 = 4.0 V	Pin 3 = 3.0 V $V_{in} = \text{Ref.1}$	Measure Pin 4 voltage when Pin 7 switch to low by increasing Pin 4 voltage from 0 V
$V_{OL(OUT)}$	Pin 1 = 0 V SW2 = C	Pin 7 = 20 mA	Measure Pin 7 voltage at 20 mA to Pin 7
		Pin 7 = 200 mA	Measure Pin 7 voltage at 200 mA to Pin 7
$V_{OH(OUT)}$	Pin 1 = 0 V Pin 4 = GND	Pin 7 = -20 mA	Measure Pin 7 voltage at -20 mA to Pin 7
		Pin 7 = -200 mA	Measure Pin 7 voltage at -200 mA to Pin 7
$V_{O(max)}$	$V_{in} = \text{Ref.1}$	SW1 = C Pin 7 = -20 mA	Measure Pin 7 voltage at -20 mA to Pin 7
$t_r$	Pin 1, 4 = 0 V SW3 = ON		
$t_f$	$V_{in} = \text{See right figure}$ $f = 50 \text{ KHz}$		
$V_{O(UVLO)}$	Pin 1 = 0 V SW1 = D	Pin 7 = 1.0 mA	Measure Pin 7 voltage at 10 mA to Pin 7
$V_{th(ON)}$	SW1 = E		Measure Pin 8 voltage when Pin 2 change to over 1 V by increasing Pin 8 voltage from 7 V
$V_{shut}$	Pin 4 = 0 V		Measure Pin 8 voltage when Pin 2 change to under 1 V by increasing Pin 8 voltage from 15 V
$V_H$	$V_{in} = 0 \text{ V}$		$V_H = V_{th(on)} - V_{shut}$
$I_{CC \text{ Startup}}$	Pin 1 = 0 V	SW1 = D	Measure Pin 8 current
Operating			
Dynamic Operating	Pin 1 = 0 V	Pin 4 = 0 V    Pin 2 = 2.5 V SW3 = ON    Pin 3 = 0.5 V $V_{in}$ : Low = 0 V, High = 4 V $f_{in}$ = Square Wave @ TBD KHz	Measure Pin 8 current

Ref.1: Pin 4 = GND,  $V_{in} = 4 \text{ V}$  return to zero pulse

# MC33232

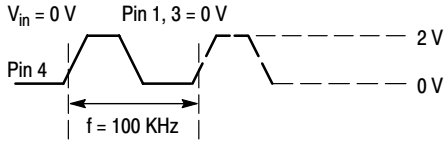
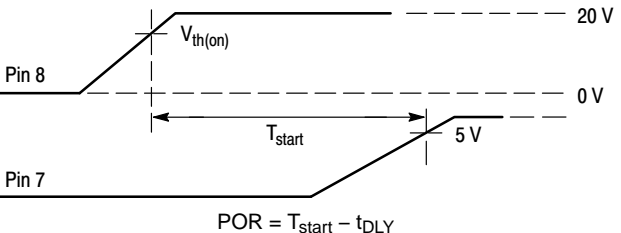
Item	Condition	Measurement Method
$V_Z$	SW1 = E Pin 8 = 25 mA Pin 5 = 2.0 V Pin 1, 4 = 0 V	Measure Pin 8 voltage
$t_{DLY}$	 $V_{in} = 0 V$ Pin 1, 3 = 0 V f = 100 KHz	Measure Pin 7 frequency (FPin 7) $t_{DLY} = 1 / F_{Pin 7}$
POR	SW1 = E Pin 4 = 0 V $V_{in} = 0 V$	 Pin 8: $V_{th(on)}$ , 20 V Pin 7: 5 V $T_{start}$ POR = $T_{start} - t_{DLY}$

## TEST CIRCUIT

To follow unless otherwise noted

SW1: A  
SW2: A  
SW3: OFF

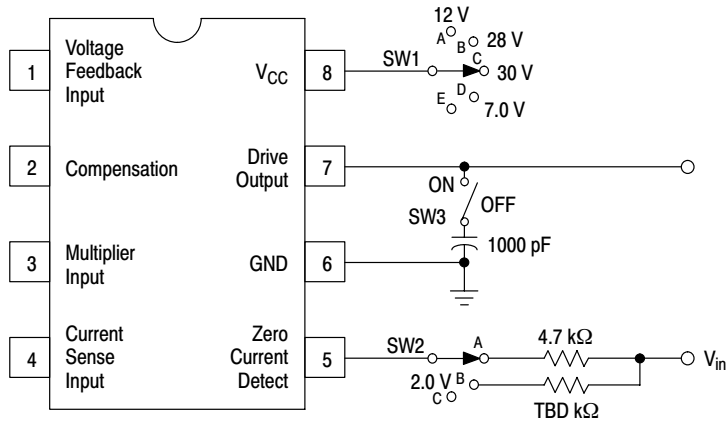

# MC33232

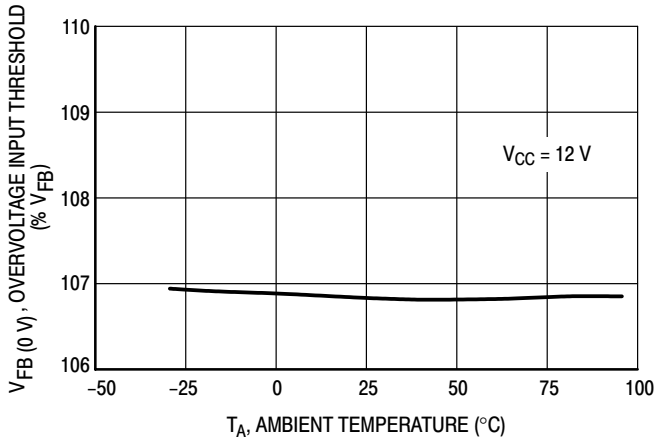

**Figure 2. Overvoltage Comparator Input Threshold versus Temperature**

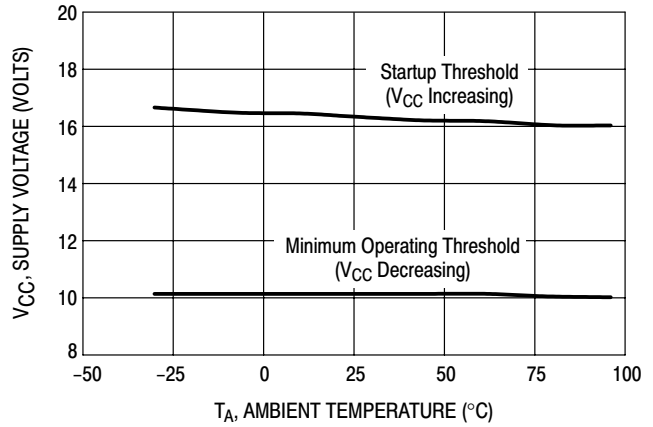

**Figure 3. Undervoltage Lockout Thresholds versus Temperature**

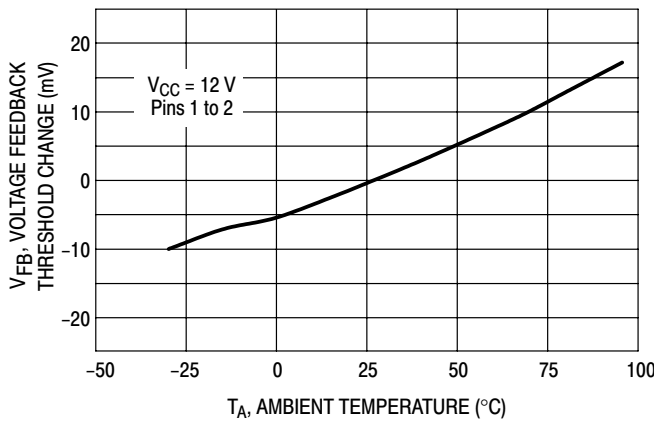

**Figure 4. Voltage Feedback Input Threshold Change versus Temperature**

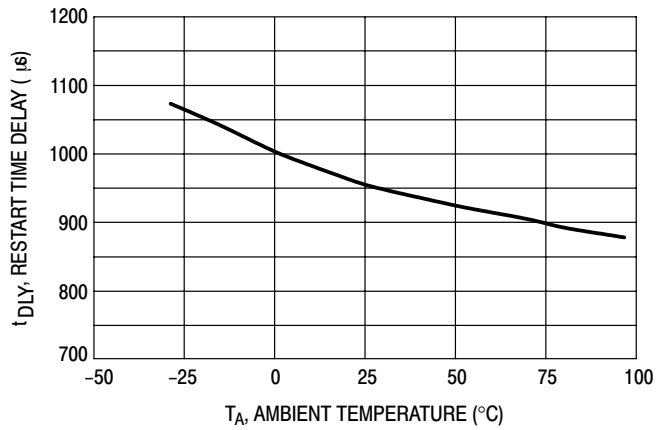

**Figure 5. Restart Timer Delay versus Temperature**

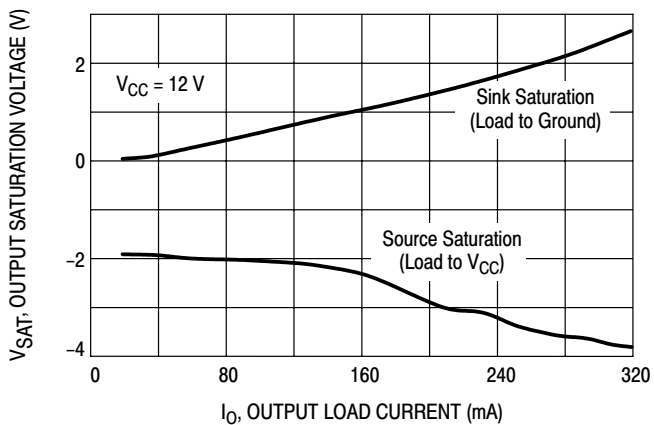

**Figure 6. Output Saturation Voltage versus Load Current**

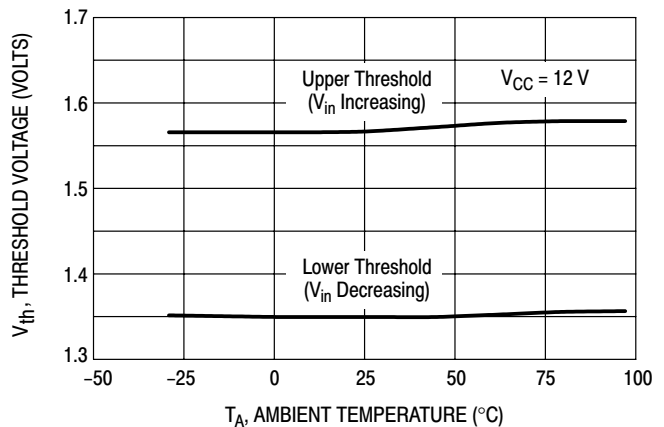

**Figure 7. Zero Current Detector Input Threshold versus Temperature**



# MC33232

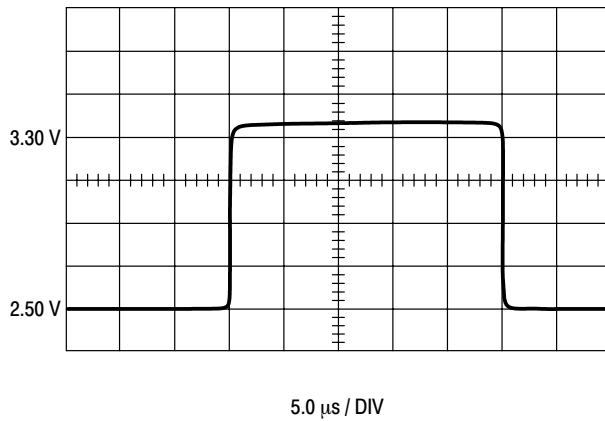

Figure 8. Error Amp Transient Response

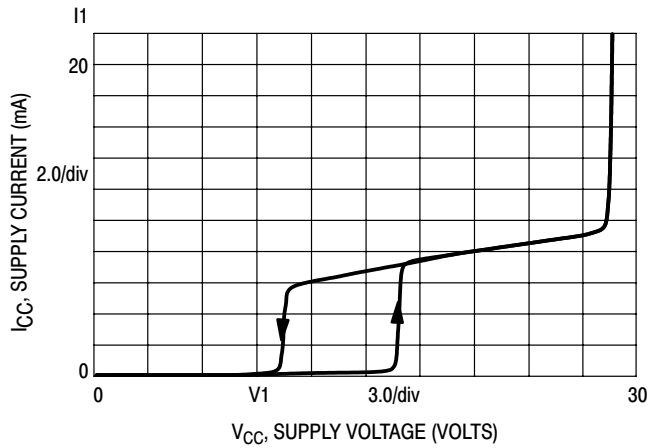

Figure 9. Supply Current versus Supply Voltage

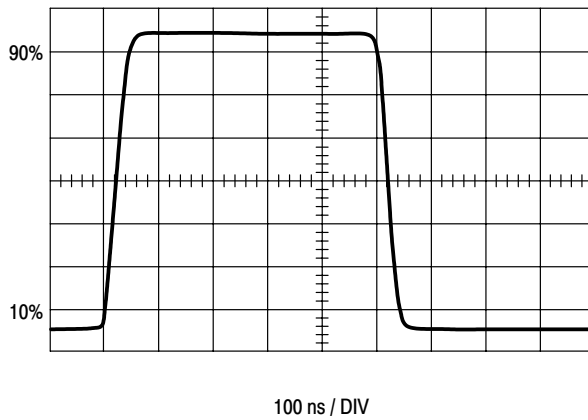

Figure 10. Drive Output Waveform

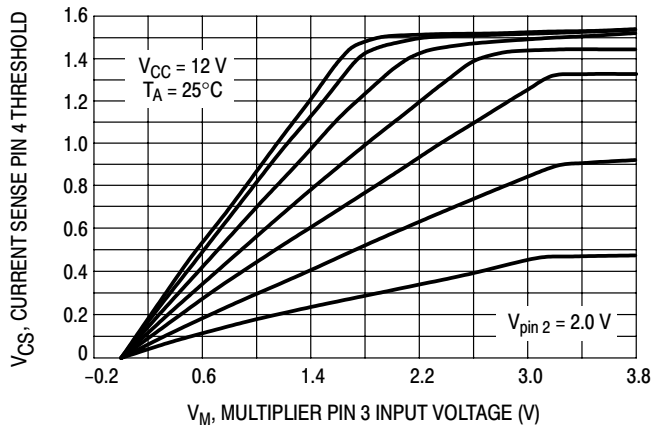

Figure 11. Restart Timer Delay versus Temperature

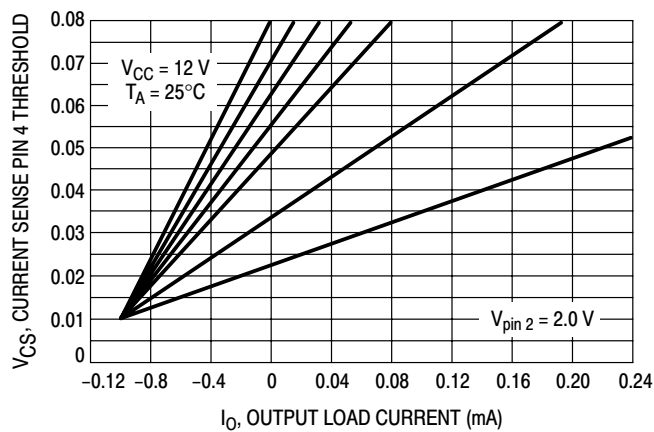

Figure 12. Current Sense Input Threshold versus Multiplier Input (Expanded View)

# MC33232

## PIN FUNCTION DESCRIPTION

Name	Pin No.	Equivalent Circuit	Function
V <sub>FB</sub>	1		<p>Voltage Feedback Input</p> <p>This pin is an input for error amplifier to feedback the voltage from the converter output. Have the overvoltage detect circuit to cut off the drive out when the voltage is over 8% from setting value.</p>
COMP	2		<p>Error Amplifier Output/Compensation</p> <p>This pin is an error amplifier output. Can do phase compensation or gain adjustment by this pin.</p>
Mult	3		<p>Multiplier Input</p> <p>Monitor the AC off line voltage using this input.</p>
CS	4		<p>Current Sense Input</p> <p>Control the output voltage by sensing the overcurrent at each cycle. This pin connects the RC filter and 1.5 V clamp diode.</p>

# MC33232

## PIN FUNCTION DESCRIPTION

Name	Pin No.	Equivalent Circuit	Function
ZCD	5		<p>Zero Current Detect Input</p> <p>Control the output ON point to detect the zero current point on the coil. This pin has the 0.7 V and 5.3 V clamp diode internal.</p>
GND	6		Ground
Output	7		Drive Out Totem pole output.
V <sub>CC</sub>	8		Power Supply

# MC33232

## INTERNAL EQUIVALENT CIRCUIT

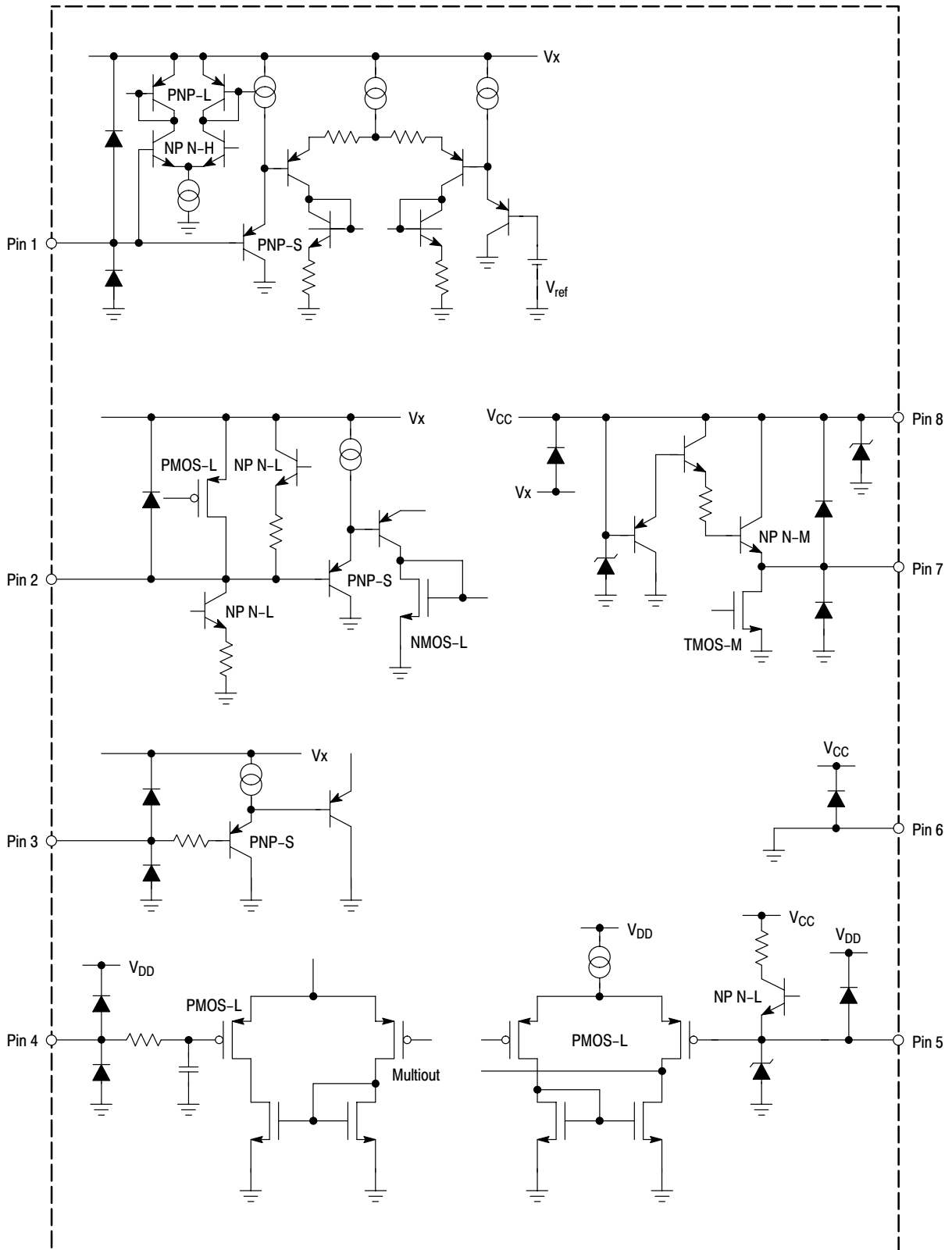

# MC33232

## SUGGESTED APPLICATION CIRCUIT

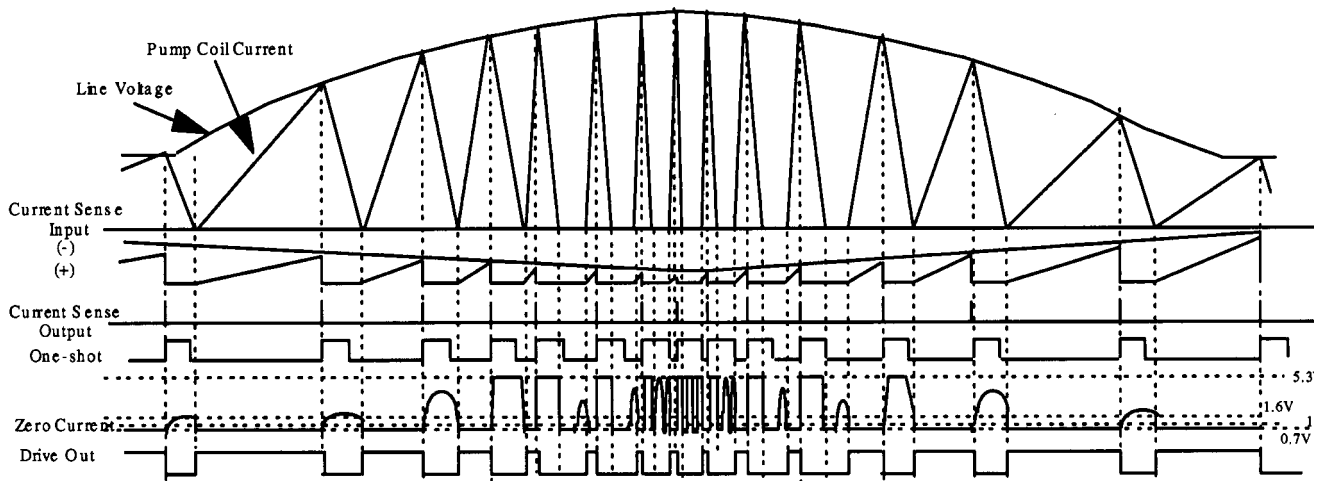
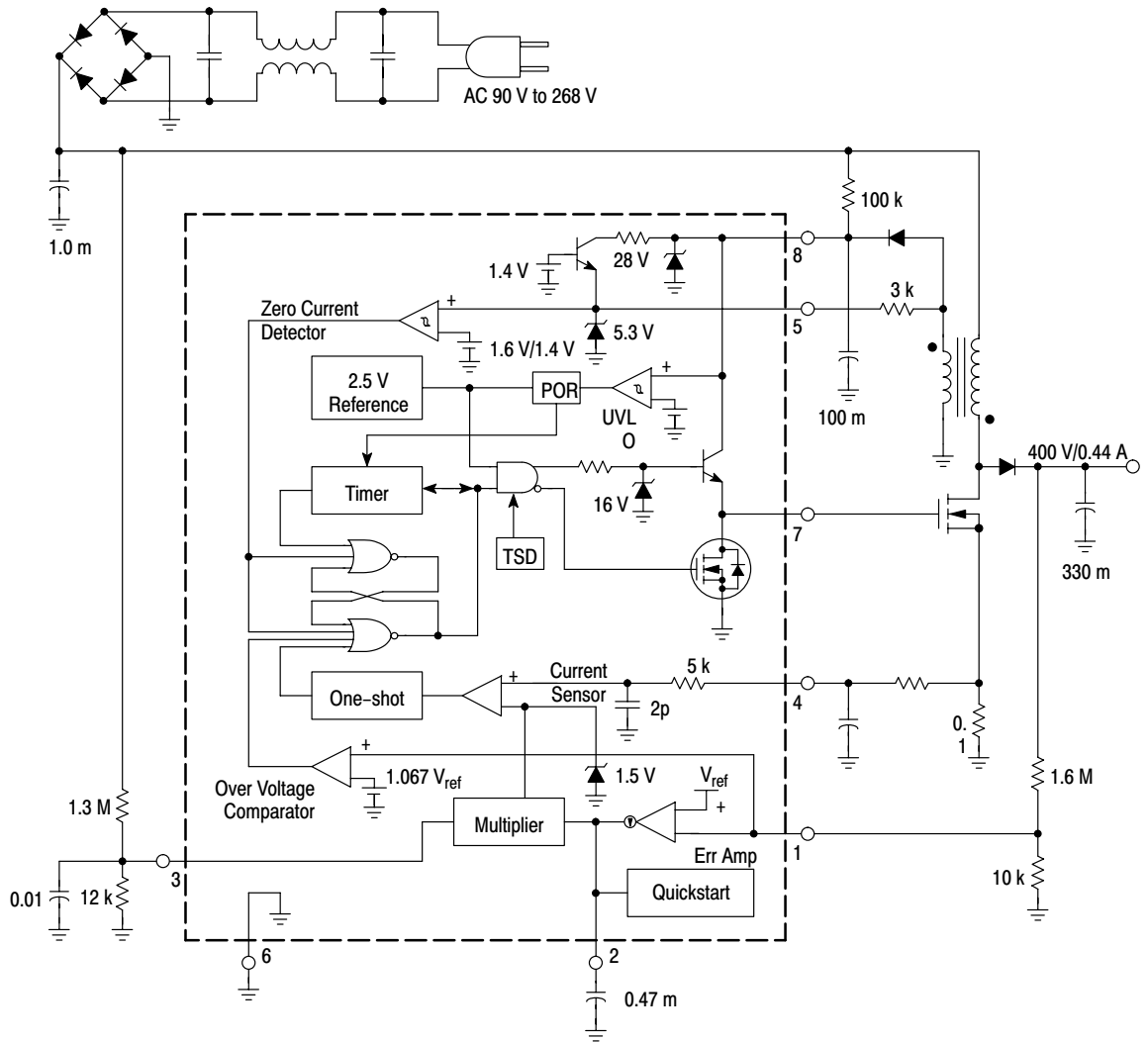



# MC33232

## PACKAGE DIMENSIONS

SOIC-8  
M SUFFIX  
CASE 751-07  
ISSUE AF

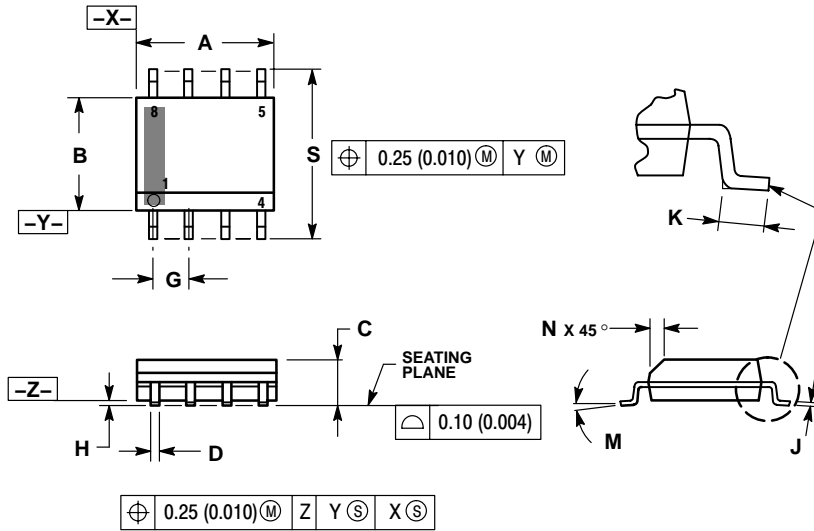

### NOTES:

1. DIMENSIONING AND TOLERANCING PER ANSI Y14.5M, 1982.
2. CONTROLLING DIMENSION: MILLIMETER.
3. DIMENSION A AND B DO NOT INCLUDE MOLD PROTRUSION.
4. MAXIMUM MOLD PROTRUSION 0.15 (0.006) PER SIDE.
5. DIMENSION D DOES NOT INCLUDE DAMBAR PROTRUSION. ALLOWABLE DAMBAR PROTRUSION SHALL BE 0.127 (0.005) TOTAL IN EXCESS OF THE D DIMENSION AT MAXIMUM MATERIAL CONDITION.
6. 751-01 THRU 751-06 ARE OBSOLETE. NEW STANDARD IS 751-07.

DIM	MILLIMETERS		INCHES	
	MIN	MAX	MIN	MAX
A	4.80	5.00	0.189	0.197
B	3.80	4.00	0.150	0.157
C	1.35	1.75	0.053	0.069
D	0.33	0.51	0.013	0.020
G	1.27 BSC		0.050 BSC	
H	0.10	0.25	0.004	0.010
J	0.19	0.25	0.007	0.010
K	0.40	1.27	0.016	0.050
M	0°	8°	0°	8°
N	0.25	0.50	0.010	0.020
S	5.80	6.20	0.228	0.244

### SOLDERING FOOTPRINT\*

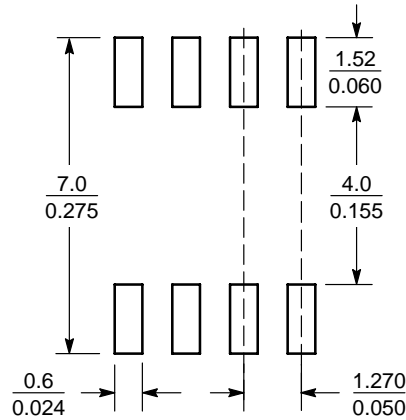

SCALE 6:1 (mm/inches)

\*For additional information on our Pb-Free strategy and soldering details, please download the ON Semiconductor Soldering and Mounting Techniques Reference Manual, SOLDERRM/D.

# MC33232

SMARTMOS is a registered trademark of Motorola, Inc.

**ON Semiconductor** and  are registered trademarks of Semiconductor Components Industries, LLC (SCILLC). SCILLC reserves the right to make changes without further notice to any products herein. SCILLC makes no warranty, representation or guarantee regarding the suitability of its products for any particular purpose, nor does SCILLC assume any liability arising out of the application or use of any product or circuit, and specifically disclaims any and all liability, including without limitation special, consequential or incidental damages. "Typical" parameters which may be provided in SCILLC data sheets and/or specifications can and do vary in different applications and actual performance may vary over time. All operating parameters, including "Typicals" must be validated for each customer application by customer's technical experts. SCILLC does not convey any license under its patent rights nor the rights of others. SCILLC products are not designed, intended, or authorized for use as components in systems intended for surgical implant into the body, or other applications intended to support or sustain life, or for any other application in which the failure of the SCILLC product could create a situation where personal injury or death may occur. Should Buyer purchase or use SCILLC products for any such unintended or unauthorized application, Buyer shall indemnify and hold SCILLC and its officers, employees, subsidiaries, affiliates, and distributors harmless against all claims, costs, damages, and expenses, and reasonable attorney fees arising out of, directly or indirectly, any claim of personal injury or death associated with such unintended or unauthorized use, even if such claim alleges that SCILLC was negligent regarding the design or manufacture of the part. SCILLC is an Equal Opportunity/Affirmative Action Employer. This literature is subject to all applicable copyright laws and is not for resale in any manner.

## PUBLICATION ORDERING INFORMATION

### LITERATURE FULFILLMENT:

Literature Distribution Center for ON Semiconductor  
P.O. Box 61312, Phoenix, Arizona 85082-1312 USA  
**Phone:** 480-829-7710 or 800-344-3860 Toll Free USA/Canada  
**Fax:** 480-829-7709 or 800-344-3867 Toll Free USA/Canada  
**Email:** [orderlit@onsemi.com](mailto:orderlit@onsemi.com)

**N. American Technical Support:** 800-282-9855 Toll Free  
USA/Canada

**Japan:** ON Semiconductor, Japan Customer Focus Center  
2-9-1 Kamimeguro, Meguro-ku, Tokyo, Japan 153-0051  
**Phone:** 81-3-5773-3850

**ON Semiconductor Website:** <http://onsemi.com>

**Order Literature:** <http://www.onsemi.com/litorder>

For additional information, please contact your  
local Sales Representative.