



# Constant-Current DC/DC LED Driver in ThinSOT

July 2001

## FEATURES

- Up to 80% Efficiency
- Inherently Matched LED Current
- Drives Five White LEDs from 2V
- Drives Six White LEDs from 2.7V
- Drives Eight White LEDs from 3V
- **Precise, Adjustable Control of LED Current**
- Disconnects LEDs In Shutdown
- 1.2MHz Fixed Frequency Switching
- Uses Tiny Ceramic Capacitors
- Uses Tiny 1mm-Tall Inductors
- Regulates Current Even When  $V_{IN} > V_{OUT}$
- Operates with  $V_{IN}$  as Low as 1V
- Low Profile (1mm) ThinSOT™ Package

## APPLICATIONS

- Cellular Telephones
- Handheld Computers
- Digital Cameras
- Portable MP3 Players
- Pagers

## DESCRIPTION

The LT<sup>®</sup>1932 is a fixed frequency step-up DC/DC converter designed to operate as a constant-current source. Because it directly regulates output current, the LT1932 is ideal for driving light emitting diodes (LEDs) whose light intensity is proportional to the current passing through them, not the voltage across their terminals.

With an input voltage range of 1V to 10V, the device works from a variety of input sources. The LT1932 accurately regulates LED current even when the input voltage is higher than the LED voltage, greatly simplifying battery-powered designs. A single external resistor sets LED current between 5mA and 40mA, which can then be easily adjusted using either a DC voltage or a pulse width modulated (PWM) signal. When the LT1932 is placed in shutdown, the LEDs are disconnected from the output, ensuring a quiescent current of under 1μA for the entire circuit. The device's 1.2MHz switching frequency permits the use of tiny, low profile chip inductors and capacitors to minimize footprint and cost in space-conscious portable applications.

LT, LTC and LT are registered trademarks of Linear Technology Corporation. ThinSOT is a trademark of Linear Technology Corporation.

## TYPICAL APPLICATION

Li-Ion Driver for Four White LEDs

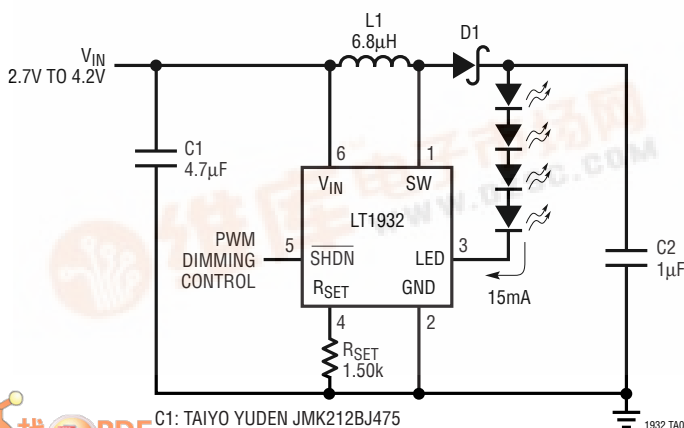

C1: TAIYO YUDEN JMK212BJ475  
C2: TAIYO YUDEN EMK212BJ105  
D1: ZETEX ZHCS400  
LT: SUMIDA CLQ4D106R8 OR PANASONIC ELJEA6R8

Efficiency

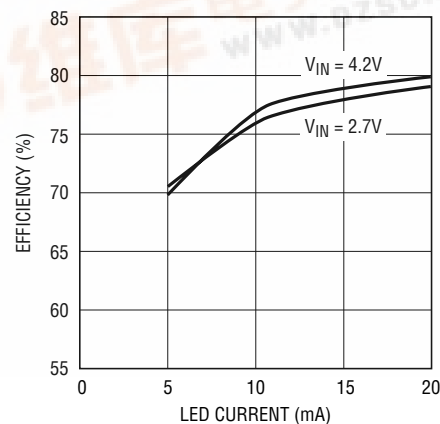

1932 TA02



# LT1932

## ABSOLUTE MAXIMUM RATINGS

(Note 1)

$V_{IN}$ Voltage .....	10V
$\overline{SHDN}$ Voltage .....	10V
SW Voltage .....	36V
LED Voltage .....	36V
$R_{SET}$ Voltage .....	1V
Junction Temperature .....	125°C
Operating Temperature Range (Note 2) ..	-40°C to 85°C
Storage Temperature Range .....	-65°C to 150°C
Lead Temperature (Soldering, 10 sec) .....	300°C

## PACKAGE/ORDER INFORMATION

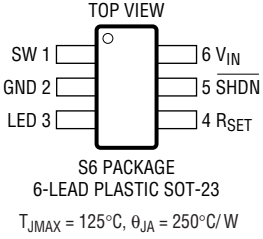
	ORDER PART NUMBER
	LT1932ES6
	S6 PART MARKING
	LTST

Consult LTC Marketing for parts specified with wider operating temperature ranges.

## ELECTRICAL CHARACTERISTICS

The ● denotes specifications that apply over the full operating temperature range, otherwise specifications are at  $T_A = 25^\circ\text{C}$ .  $V_{IN} = 1.2\text{V}$ ,  $V_{\overline{SHDN}} = 1.2\text{V}$ , unless otherwise noted.

PARAMETER	CONDITIONS	MIN	TYP	MAX	UNITS
Minimum Input Voltage				1	V
Quiescent Current	$V_{RSET} = 0.2\text{V}$ $V_{\overline{SHDN}} = 0\text{V}$		1.2 0.1	1.6 1.0	mA $\mu\text{A}$
$R_{SET}$ Pin Voltage	$R_{SET} = 1.50\text{k}$		100		mV
LED Pin Voltage	$R_{SET} = 1.50\text{k}$ , $V_{IN} < V_{OUT}$ (Figure 1)		120	180	mV
LED Pin Current	$R_{SET} = 562\Omega$ , $V_{IN} = 1.5\text{V}$ $R_{SET} = 750\Omega$ , $V_{IN} = 1.2\text{V}$ $R_{SET} = 1.50\text{k}$ , $V_{IN} = 1.2\text{V}$ $R_{SET} = 4.53\text{k}$ , $V_{IN} = 1.2\text{V}$	34 26 12.5	38 30 15	42 34 17.5	mA mA mA mA
LED Pin Current Temperature Coefficient	$I_{LED} = 15\text{mA}$		-0.02		$\text{mA}/^\circ\text{C}$
Switching Frequency	$V_{IN} = 1\text{V}$	0.8	1.2	1.6	MHz
Maximum Switch Duty Cycle		● 90	95		%
Switch Current Limit		400	550	780	mA
Switch $V_{CESAT}$	$I_{SW} = 300\text{mA}$		150	200	mV
$\overline{SHDN}$ Pin Current	$V_{\overline{SHDN}} = 0\text{V}$ $V_{\overline{SHDN}} = 2\text{V}$		0 15	0.1 30	$\mu\text{A}$ $\mu\text{A}$
Start-Up Threshold ( $\overline{SHDN}$ Pin)		0.85			V
Shutdown Threshold ( $\overline{SHDN}$ Pin)				0.25	V
Switch Leakage Current	Switch Off, $V_{SW} = 5\text{V}$		0.01	5	$\mu\text{A}$

**Note 1:** Absolute Maximum Ratings are those values beyond which the life of a device may be impaired.

**Note 2:** The LT1932E is guaranteed to meet specifications from 0°C to 70°C. Specifications over the -40°C to 85°C operating temperature range are assured by design, characterization and correlation with statistical process controls.

# TYPICAL PERFORMANCE CHARACTERISTICS

Switch Saturation Voltage ( $V_{CESAT}$ )

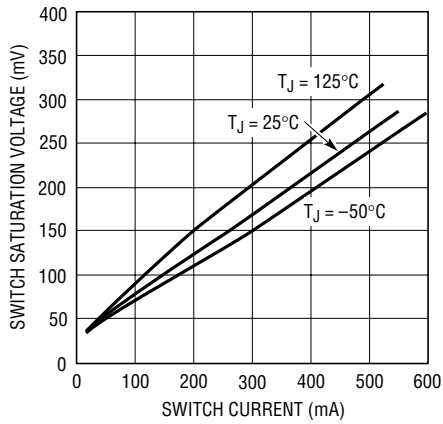

1932 G01

Switch Current Limit

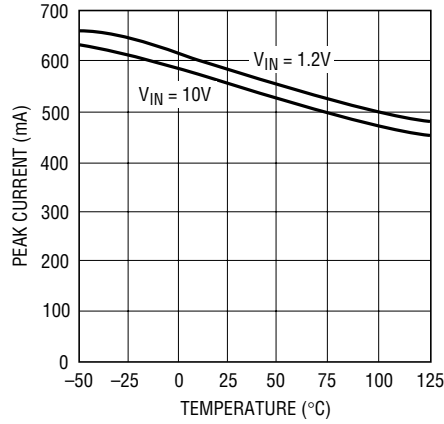

1932 G02

Switching Frequency

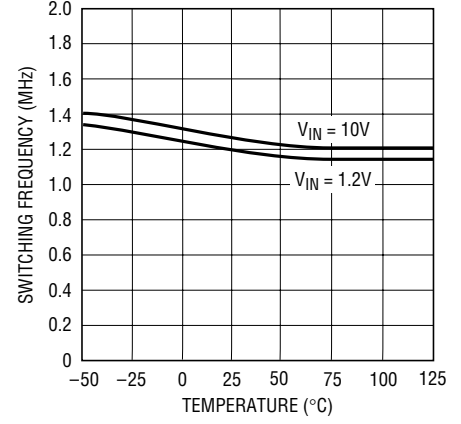

1932 G03

LED Pin Voltage

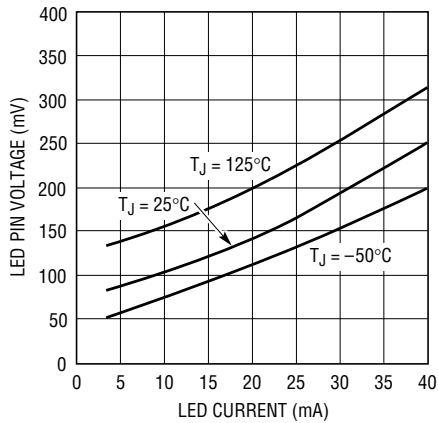

1932 G04

LED Current

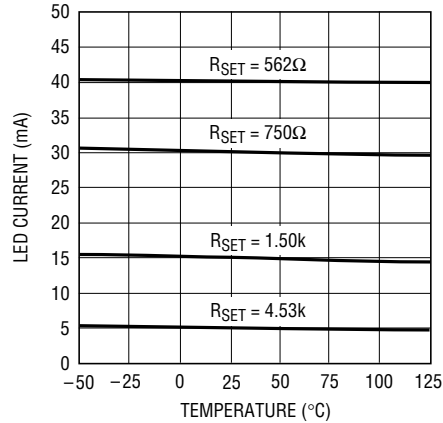

1932 G05

LED Current

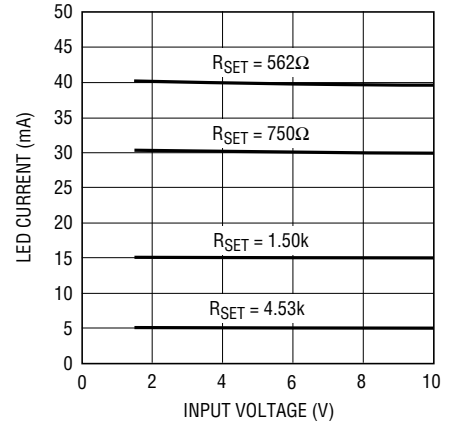

1932 G06

Quiescent Current

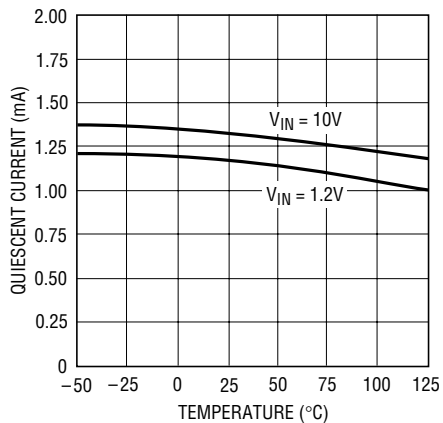

1932 G07

SHDN Pin Current

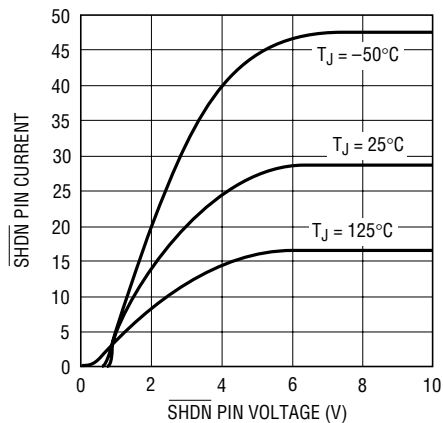

1932 G08

Switching Waveforms

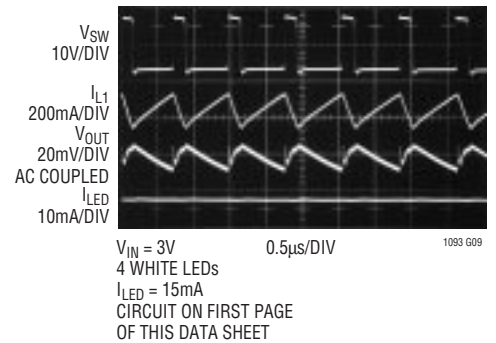

# LT1932

## PIN FUNCTIONS

**SW (Pin 1):** Switch Pin. This is the collector of the internal NPN power switch. Minimize the metal trace area connected to this pin to minimize EMI.

**GND (Pin 2):** Ground Pin. Tie this pin directly to local ground plane.

**LED (Pin 3):** LED Pin. This is the collector of the internal NPN LED switch. Connect the cathode of the bottom LED to this pin.

**R<sub>SET</sub> (Pin 4):** A resistor between this pin and ground programs the LED current (that flows into the LED pin). This pin is also used to provide LED dimming.

**SHDN (Pin 5):** Shutdown Pin. Tie this pin higher than 0.85V to turn on the LT1932; tie below 0.25V to turn it off.

**V<sub>IN</sub> (Pin 6):** Input Supply Pin. Bypass this pin with a capacitor to ground as close to the device as possible.

## BLOCK DIAGRAM

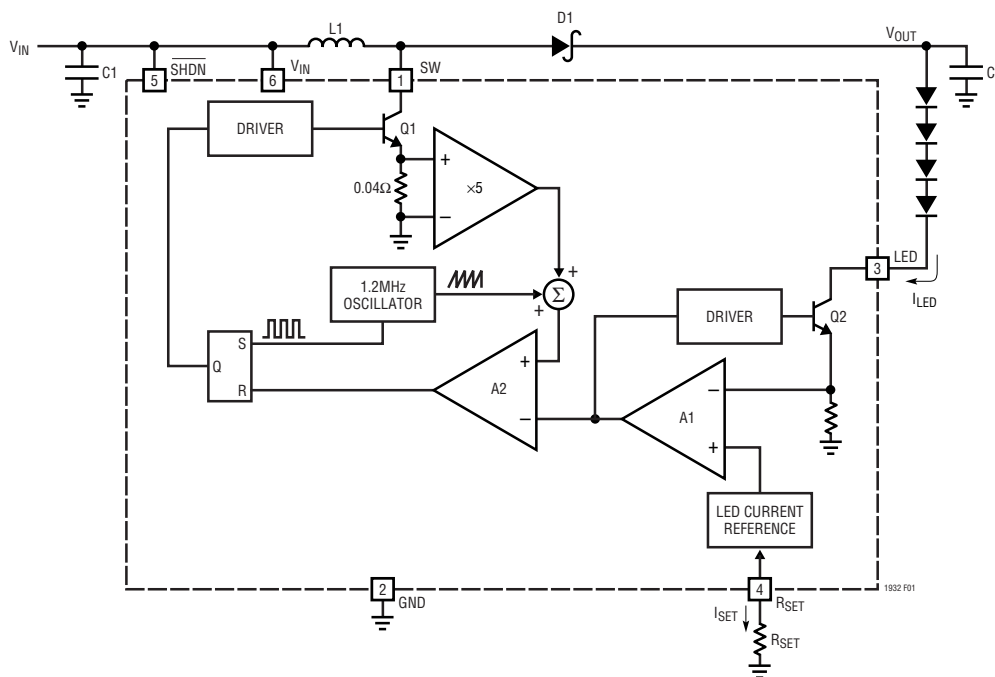

Figure 1. LT1932 Block Diagram

## OPERATION

The LT1932 uses a constant frequency, current mode control scheme to regulate the output current,  $I_{LED}$ . Operation can be best understood by referring to the block diagram in Figure 1. At the start of each oscillator cycle, the SR latch is set, turning on power switch Q1. The signal at the noninverting input of the PWM comparator A2 is proportional to the switch current, summed together with a portion of the oscillator ramp. When this signal reaches the level set by the output of error amplifier A1, comparator A2 resets the latch and turns off the

power switch. In this manner, A1 sets the correct peak current level to keep the LED current in regulation. If A1's output increases, more current is delivered to the output; if it decreases, less current is delivered. A1 senses the LED current in switch Q2 and compares it to the current reference, which is programmed using resistor  $R_{SET}$ . The  $R_{SET}$  pin is regulated to 100mV and the output current,  $I_{LED}$ , is regulated to  $225 \cdot I_{SET}$ . Pulling the  $R_{SET}$  pin higher than 100mV will pull down the output of A1, turning off power switch Q1 and LED switch Q2.

## APPLICATIONS INFORMATION

### Inductor Selection

Several inductors that work well with the LT1932 are listed in Table 1. Many different sizes and shapes are available. Consult each manufacturer for more detailed information and for their entire selection of related parts. As core losses at 1.2MHz are much lower for ferrite cores than for the cheaper powdered-iron ones, ferrite core inductors should be used to obtain the best efficiency. Choose an inductor that can handle at least 0.5A and ensure that the inductor has a low DCR (copper wire resistance) to minimize  $I^2R$  power losses. A 4.7 $\mu$ H or 6.8 $\mu$ H inductor will be a good choice for most LT1932 designs.

**Table 1. Recommended Inductors**

PART	L ( $\mu$ H)	MAX DCR (m $\Omega$ )	MAX HEIGHT (mm)	VENDOR
ELJEA4R7 ELJEA6R8	4.7 6.8	180 250	2.2 2.2	Panasonic (714) 373-7334 www.panasonic.com
LQH3C4R7M24 LQH3C100M24	4.7 10	260 300	2.2 2.2	Murata (814) 237-1431 www.murata.com
LB2016B4R7 LB2016B100	4.7 6.8	250 350	2.0 2.0	Taiyo Yuden (408) 573-4150 www.t-yuden.com
CMD4D06-4R7 CMD4D06-6R8 CLQ4D10-4R7 CLQ4D10-6R8	4.7 6.8 4.7 6.8	216 296 162 195	0.8 0.8 1.2 1.2	Sumida (847) 956-0666 www.sumida.com

### Inductor Efficiency Considerations

Many applications have thickness requirements that restrict component heights to 1mm or 2mm. There are 2mm tall inductors currently available that provide a low DCR and low core losses that help provide good overall efficiency. Inductors with a height of 1mm (and less) are becoming more common, and a few companies have introduced chip inductors that are not only thin, but have a very small footprint as well. While these smaller inductors will be a necessity in some designs, their smaller size gives higher DCR and core losses, resulting in lower efficiencies. Figure 2 shows efficiency for the Typical Application circuit on the front page of this data sheet, with several different inductors. The larger devices improve

efficiency by up to 12% over the smaller, thinner ones. Keep this in mind when choosing an inductor.

The value of inductance also plays an important role in the overall system efficiency. While a 1 $\mu$ H inductor will have a lower DCR and a higher current rating than the 6.8 $\mu$ H version of the same part, lower inductance will result in higher peak currents in the switch, inductor and diode. Efficiency will suffer if inductance is too small. Figure 3 shows the efficiency of the Typical Application on the front page of this data sheet, with several different values of the same type of inductor (Panasonic ELJEA). The smaller values give an efficiency 3% to 5% lower than the 6.8 $\mu$ H value.

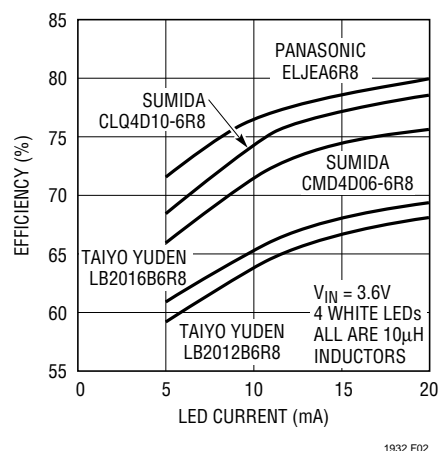

**Figure 2. Efficiency for Several Different Inductor Types**

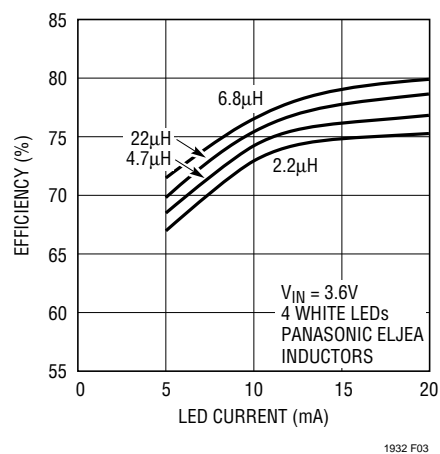

**Figure 3. Efficiency for Several Different Inductor Values**

## APPLICATIONS INFORMATION

### Capacitor Selection

Low ESR (equivalent series resistance) capacitors should be used at the output to minimize the output ripple voltage. Because they have an extremely low ESR and are available in very small packages, multilayer ceramic capacitors are an excellent choice. X5R and X7R type capacitors are preferred because they retain their capacitance over wider voltage and temperature ranges than other types such as Y5V or Z5U. A 1µF or 2.2µF output capacitor is sufficient for most applications. Always use a capacitor with a sufficient voltage rating. Ceramic capacitors do not need to be derated (do not buy a capacitor with a rating twice what your application needs). A 16V ceramic capacitor is good to more than 16V, unlike a 16V tantalum, which may be good to only 8V when used in certain applications. Low profile ceramic capacitors with a 1mm maximum thickness are available for designs having strict height requirements.

Ceramic capacitors also make a good choice for the input decoupling capacitor, which should be placed as close as possible to the LT1932. A 2.2µF or 4.7µF input capacitor is sufficient for most applications. Table 2 shows a list of several ceramic capacitor manufacturers. Consult the manufacturers for detailed information on their entire selection of ceramic parts.

**Table 2. Recommended Ceramic Capacitor Manufacturers**

VENDOR	PHONE	URL
Taiyo Yuden	(408) 573-4150	www.t-yuden.com
Murata	(814) 237-1431	www.murata.com
Kemet	(408) 986-0424	www.kemet.com

### Diode Selection

Schottky diodes, with their low forward voltage drop and fast switching speed, are the ideal choice for LT1932 applications. Table 3 shows several different Schottky diodes that work well with the LT1932. Make sure that the diode has a voltage rating greater than the output voltage. The diode conducts current only when the power switch is

turned off (typically less than one-third the time), so a 0.4A or 0.5A diode will be sufficient for most designs.

**Table 3. Recommended Schottky Diodes**

PART	VENDOR
MBR0520 MBR0530 MBR0540	ON Semiconductor (800) 282-9855 www.onsemi.com
ZHCS400 ZHCS500	Zetex (631) 543-7100 www.zetex.com

### Programming LED Current

The LED current is programmed with a single resistor connected to the R<sub>SET</sub> pin (see Figure 1). The R<sub>SET</sub> pin is internally regulated to 100mV, which sets the current flowing out of this pin, I<sub>SET</sub>, equal to 100mV/R<sub>SET</sub>. The LT1932 regulates the current into the LED pin, I<sub>LED</sub>, to 225 times the value of I<sub>SET</sub>. For the best accuracy, a 1% (or better) resistor value should be used. Table 4 shows several typical 1% R<sub>SET</sub> values. For other LED current values, use the following equation to choose R<sub>SET</sub>.

$$R_{SET} = 225 \cdot \left( \frac{0.1V}{I_{LED}} \right)$$

**Table 4. R<sub>SET</sub> Resistor Values**

I <sub>LED</sub> (mA)	R <sub>SET</sub> VALUE
40	562Ω
30	750Ω
20	1.13k
15	1.50k
10	2.26k
5	4.53k

Most white LEDs are driven at maximum currents of 15mA to 20mA. Some higher power designs will use two parallel strings of LEDs for greater light output, resulting in 30mA to 40mA (two strings of 15mA to 20mA) flowing into the LED pin.

## APPLICATIONS INFORMATION

### Open-Circuit Protection

For applications where the string of LEDs can be disconnected or could potentially become an open circuit, a zener diode can be added across the LEDs to protect the LT1932 (see Figure 4). If the device is turned on without the LEDs present, no current feedback signal is provided to the LED pin. The LT1932 will then switch at its maximum duty cycle, generating an output voltage 10 to 15 times greater than the input voltage. Without the zener, the SW pin could see more than 36V and exceed its maximum rating. The zener voltage should be larger than the maximum forward voltage of the LED string.

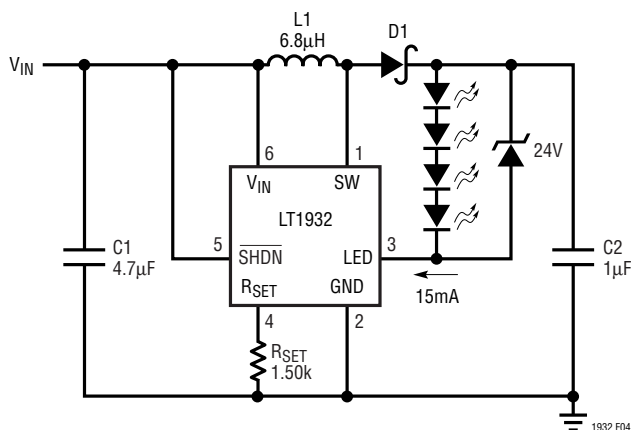

Figure 4. LED Driver with Open-Circuit Protection

### Dimming Using a PWM Signal

PWM brightness control provides the widest dimming range (greater than 20:1) by pulsing the LEDs on and off using the control signal. The LEDs operate at either zero or full current, but their average current changes with the PWM signal duty cycle. Typically, a 5kHz to 40kHz PWM signal is used. PWM dimming with the LT1932 can be accomplished two different ways (see Figure 6). The SHDN pin can be driven directly or a resistor can be added to drive the RSET pin.

If the SHDN pin is used, increasing the duty cycle will increase the LED brightness. Using this method, the LEDs can be dimmed and turned off completely using the same control signal. A 0% duty cycle signal will turn off the LT1932, reducing the total quiescent current to zero.

If the RSET pin is used, increasing the duty cycle will decrease the brightness. Using this method, the LEDs are dimmed using RSET and turned off completely using SHDN. If the RSET pin is used to provide PWM dimming, the approximate value of R<sub>PWM</sub> should be (where V<sub>MAX</sub> is the “high” value of the PWM signal):

$$R_{PWM} = R_{SET} \cdot \left( \frac{V_{MAX}}{0.15V} - 1 \right)$$

In addition to providing the widest dimming range, PWM brightness control also ensures the “purest” white LED color over the entire dimming range. The true color of a white LED changes with operating current, and is the “purest” white at a specific forward current, usually 15mA or 20mA. If the LED current is less than or more than this value, the emitted light becomes more blue. For color LCDs, this often results in a noticeable and undesirable blue tint to the display.

When a PWM control signal is used to drive the SHDN pin of the LT1932 (see Figure 6), the LEDs are turned off and on at the PWM frequency. The current through them alternates between full current and zero current, so the average current changes with duty cycle. This ensures that when the LEDs are on, they can be driven at the appropriate current to give the purest white light. Figure 5 shows the LED current when a 5kHz PWM dimming control signal is used with the LT1932. The LED current waveform cleanly tracks the PWM control signal with no delays, so the LED brightness varies linearly with the PWM duty cycle.

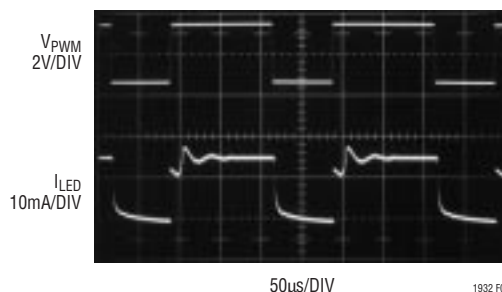

Figure 5. PWM Dimming Using the SHDN Pin

## APPLICATIONS INFORMATION

### Dimming Using a Filtered PWM Signal

While the direct PWM method provides the widest dimming range and the purest white light output, it causes the LT1932 to enter into Burst Mode™ operation. This operation may be undesirable for some systems, as it may reflect some noise to the input source at the PWM frequency. The solution is to filter the control signal by adding a 10k resistor and a 0.1µF capacitor as shown in Figure 6, converting the PWM to a DC level before it reaches the R<sub>SET</sub> pin. The 10k resistor minimizes the capacitance seen by the R<sub>SET</sub> pin.

### Dimming Using a Logic Signal

For applications that need to adjust the LED brightness in discrete steps, a logic signal can be used as shown in Figure 6. R<sub>MIN</sub> sets the minimum LED current value (when the NMOS is off):

$$R_{MIN} = 225 \cdot \left( \frac{0.1V}{I_{LED(MIN)}} \right)$$

R<sub>INCR</sub> sets how much the LED current is increased when the NMOS is turned on:

$$R_{INCR} = 225 \cdot \left( \frac{0.1V}{I_{LED(INCREASE)}} \right)$$

### Dimming Using a DC Voltage

For some applications, the preferred method of brightness control uses a variable DC voltage to adjust the LED current. As the DC voltage is increased, current flows through R<sub>ADJ</sub> into R<sub>SET</sub>, reducing the current flowing out of the R<sub>SET</sub> pin, thus reducing the LED current. Choose the R<sub>ADJ</sub> value as shown below where V<sub>MAX</sub> is the maximum DC control voltage, I<sub>LED(MAX)</sub> is the current programmed by R<sub>SET</sub>, and I<sub>LED(MIN)</sub> is the minimum value of I<sub>LED</sub> (when the DC control voltage is at V<sub>MAX</sub>).

$$R_{ADJ} = 225 \cdot \left( \frac{V_{MAX} - 0.1V}{I_{LED(MAX)} - I_{LED(MIN)}} \right)$$

### Regulating LED Current when V<sub>IN</sub> > V<sub>OUT</sub>

The LT1932 contains special circuitry that enables it to regulate the LED current even when the input voltage is higher than the output voltage. When V<sub>IN</sub> is less than V<sub>OUT</sub>, the internal NPN LED switch (transistor Q2 in Figure 1) is saturated to provide a lower power loss. When V<sub>IN</sub> is greater than V<sub>OUT</sub>, the NPN LED switch comes out of saturation to keep the LED current in regulation.

Burst Mode is a trademark of Linear Technology Corporation.

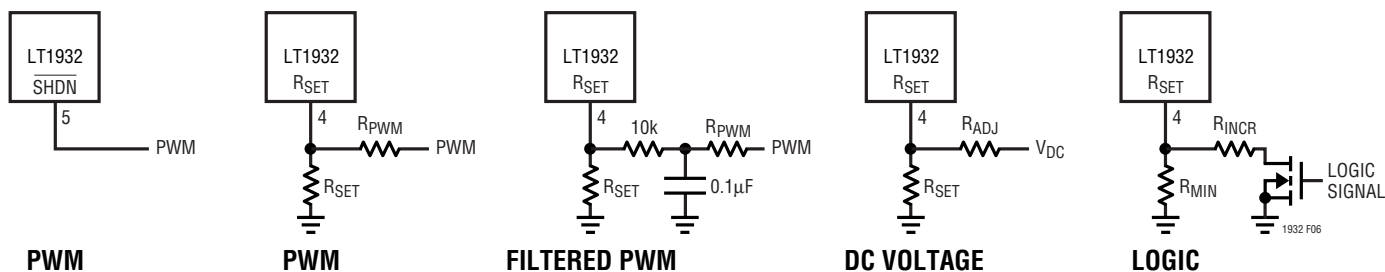

Figure 6. Five Methods of LED Dimming



## APPLICATIONS INFORMATION

### Board Layout Considerations

As with all switching regulators, careful attention must be paid to the PCB board layout and component placement. To maximize efficiency, switch rise and fall times are made as short as possible. To prevent radiation and high frequency resonance problems, proper layout of the high frequency switching path is essential. Minimize the length and area of all traces connected to the SW pin and always use a ground plane under the switching regulator to minimize interplane coupling. The signal path including the switch, output diode D1 and output capacitor C2, contains nanosecond rise and fall times and should be kept as short as possible. In addition, the ground connection for the R<sub>SET</sub> resistor should be tied directly to the GND pin and not be shared with any other component, ensuring a clean, noise-free connection. Recommended component placement is shown in Figure 7.

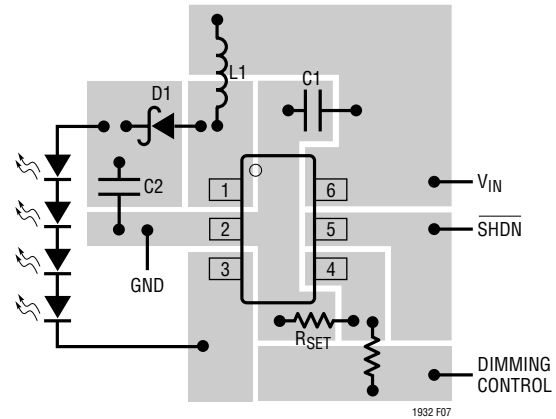
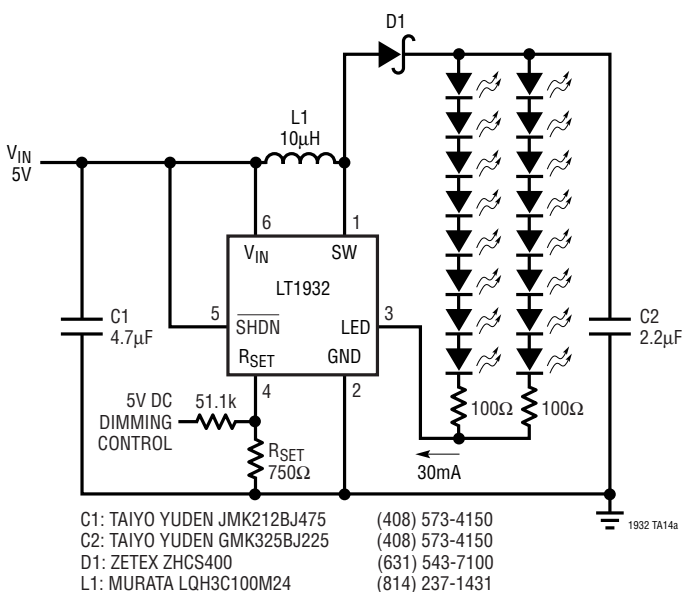

Figure 7. Recommended Component Placement

## TYPICAL APPLICATIONS

### 5V Driver for 16 White LEDs



### Efficiency

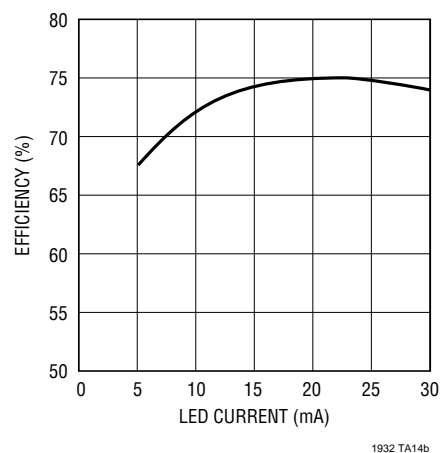

# LT1932

## TYPICAL APPLICATIONS

### Single Cell Driver for One White LED

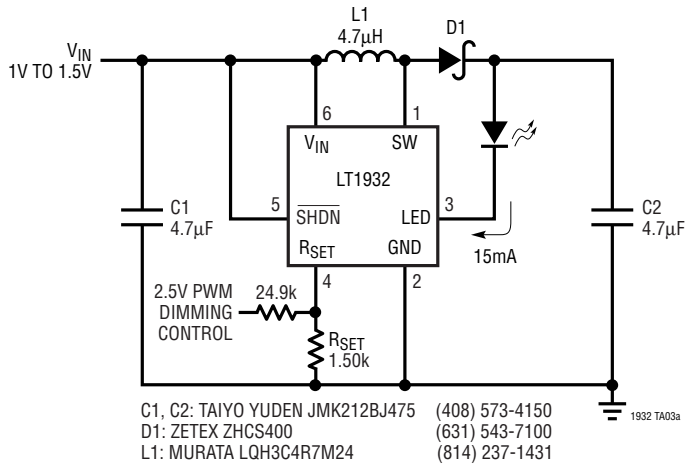

### Efficiency

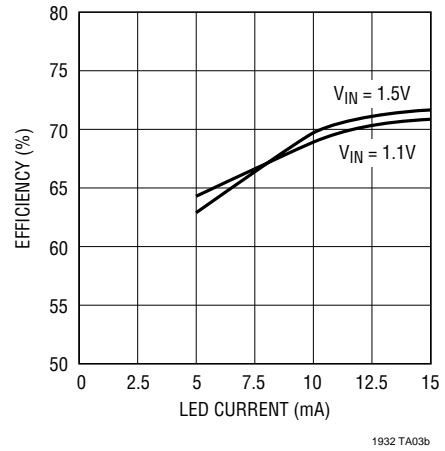

### Single Cell Driver for Two White LEDs

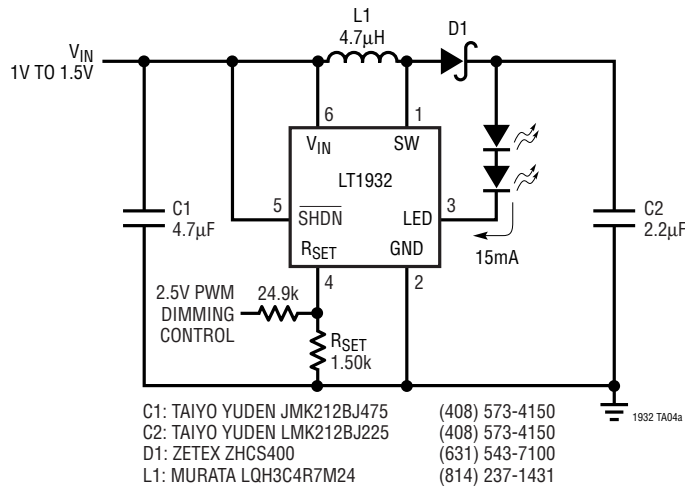

### Efficiency

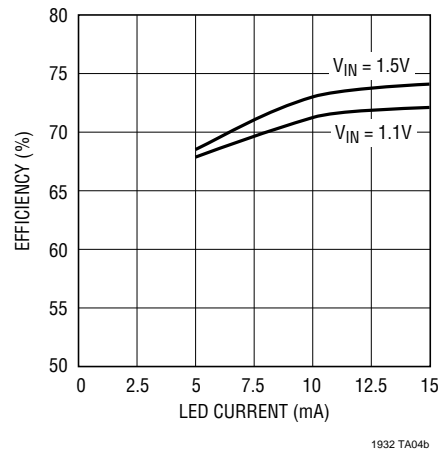

# TYPICAL APPLICATIONS

2-Cell Driver for Two White LEDs

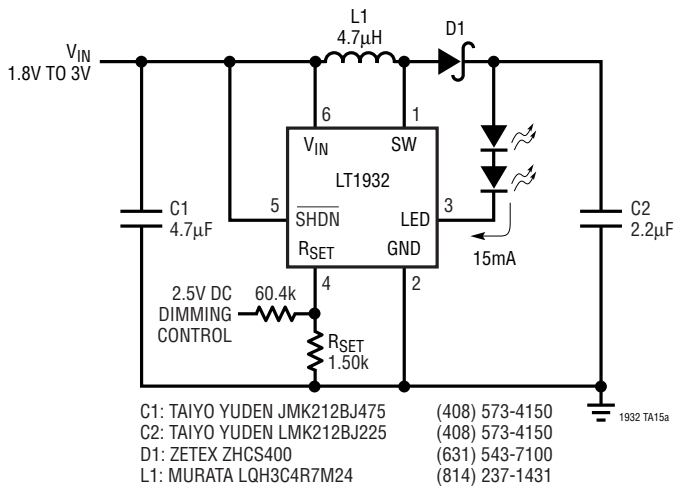

Efficiency

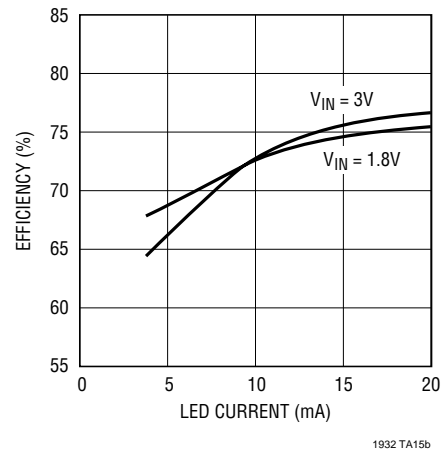

2-Cell Driver for Three White LEDs

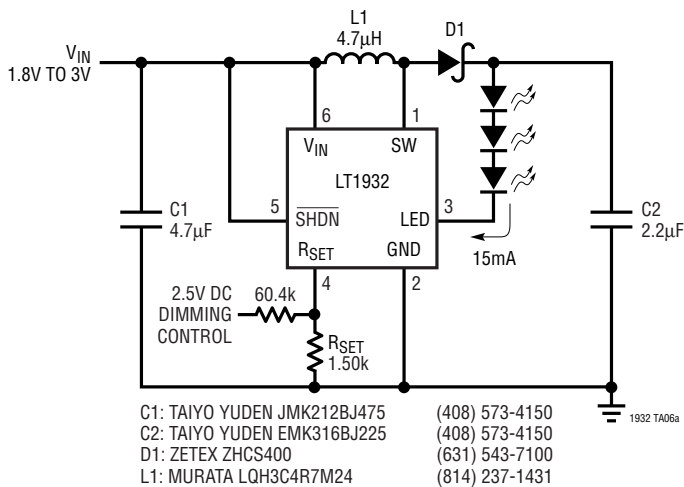

Efficiency

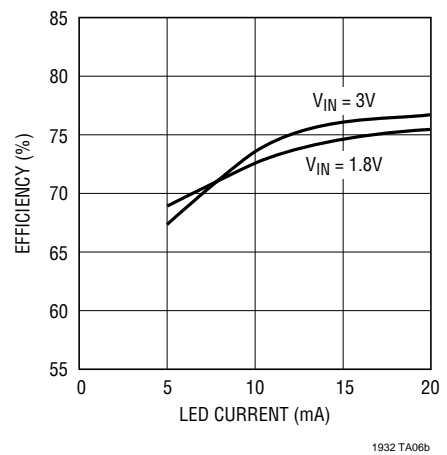

# LT1932

## TYPICAL APPLICATIONS

### 2-Cell Driver for Four White LEDs

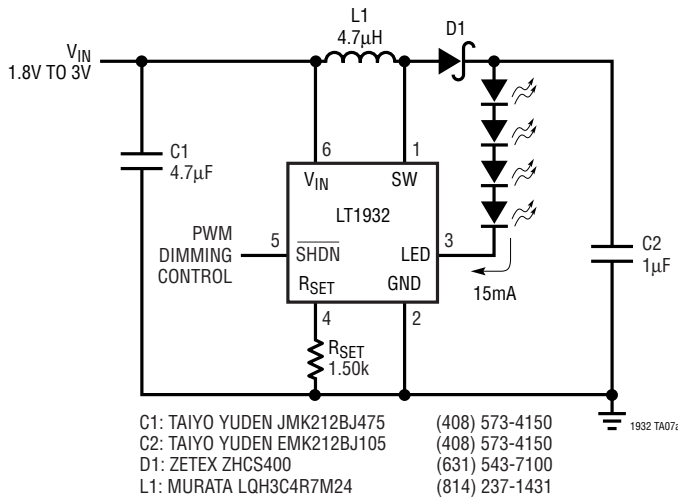

### Efficiency

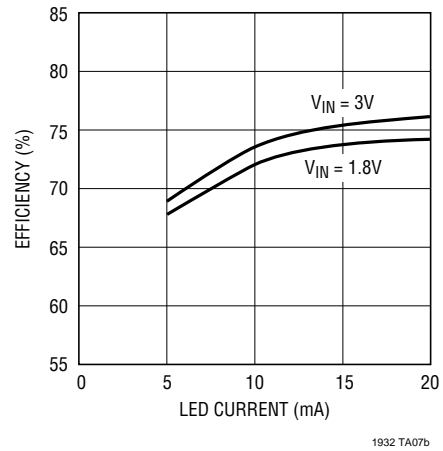

### 2-Cell Driver for Five White LEDs

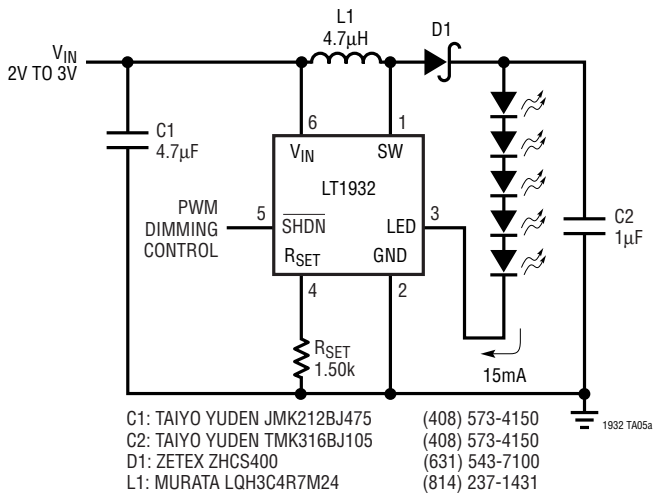

### Efficiency

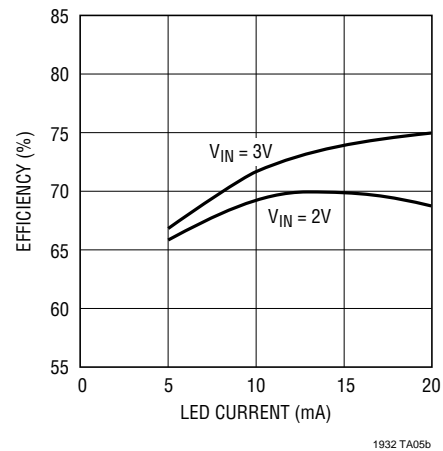

# TYPICAL APPLICATIONS

Li-Ion Driver for Two White LEDs

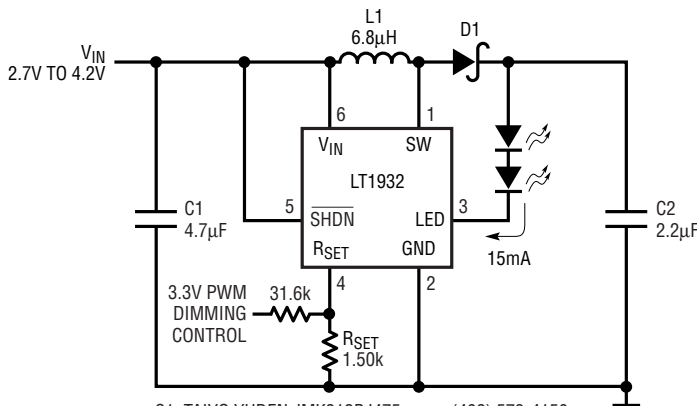

- |                             |                |
|-----------------------------|----------------|
| C1: TAIYO YUDEN JMK212BJ475 | (408) 573-4150 |
| C2: TAIYO YUDEN LMK212BJ225 | (408) 573-4150 |
| D1: ZETEX ZHCS400           | (631) 543-7100 |
| L1: PANASONIC ELJEA6R8      | (714) 373-7334 |

1932 TA08a

Efficiency

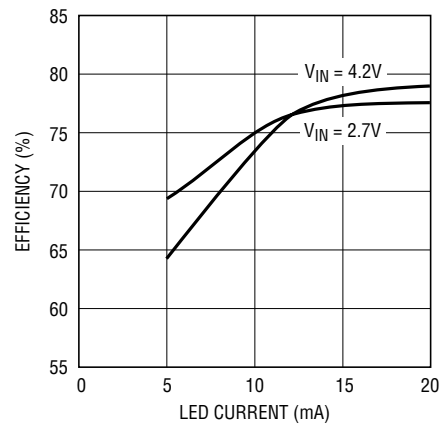

1932 TA08b

Li-Ion Driver for Three White LEDs

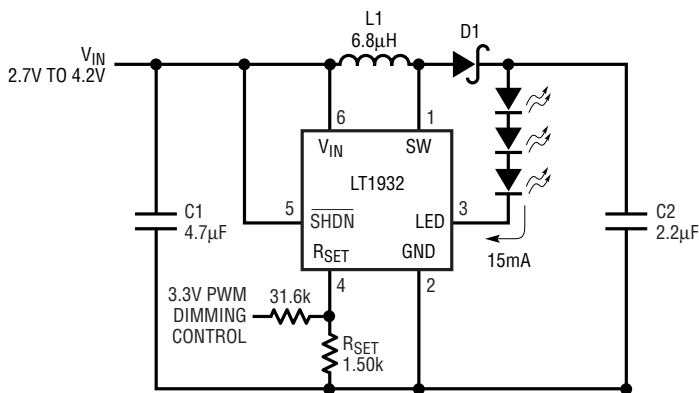

- |                             |                |
|-----------------------------|----------------|
| C1: TAIYO YUDEN JMK212BJ475 | (408) 573-4150 |
| C2: TAIYO YUDEN EMK316BJ225 | (408) 573-4150 |
| D1: ZETEX ZHCS400           | (631) 543-7100 |
| L1: PANASONIC ELJEA6R8      | (714) 373-7334 |

1932 TA09a

Efficiency

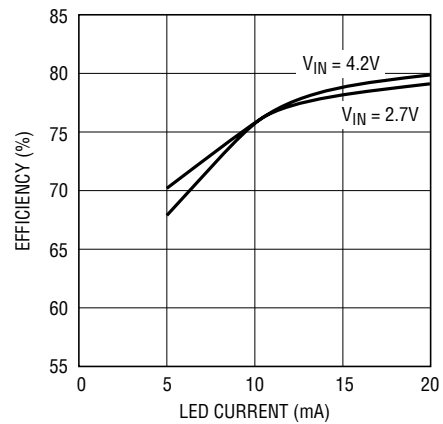

1932 TA09b

# LT1932

## TYPICAL APPLICATIONS

### Li-Ion Driver for Four White LEDs

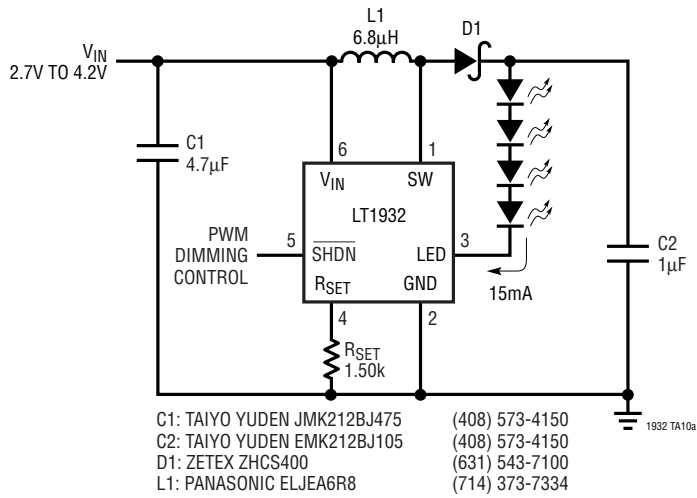

### Efficiency

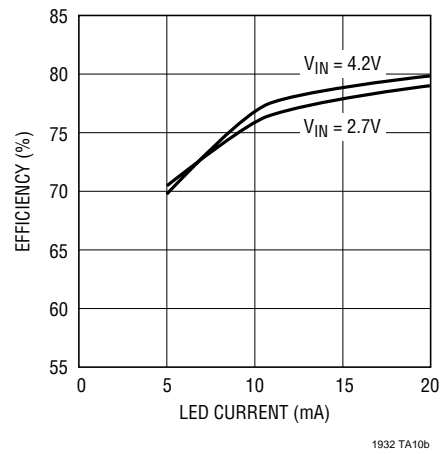

### Li-Ion Driver for Five White LEDs

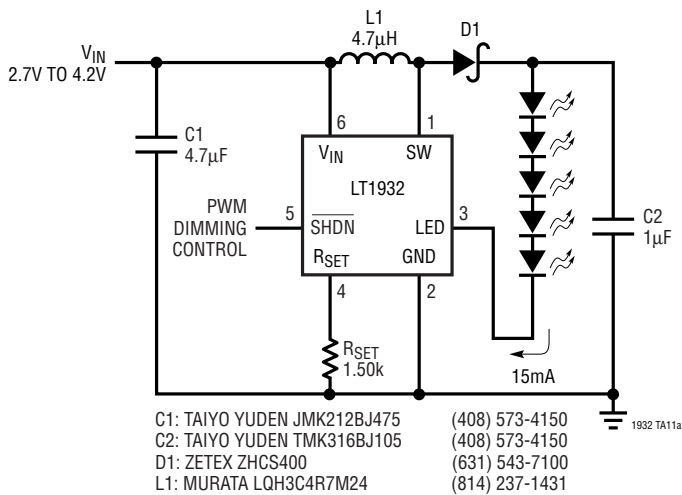

### Efficiency

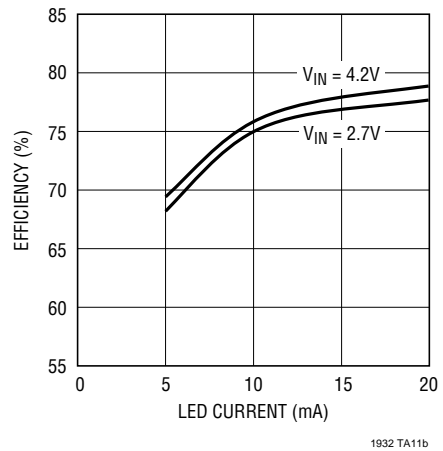

# TYPICAL APPLICATIONS

Li-Ion Driver for Eight White LEDs

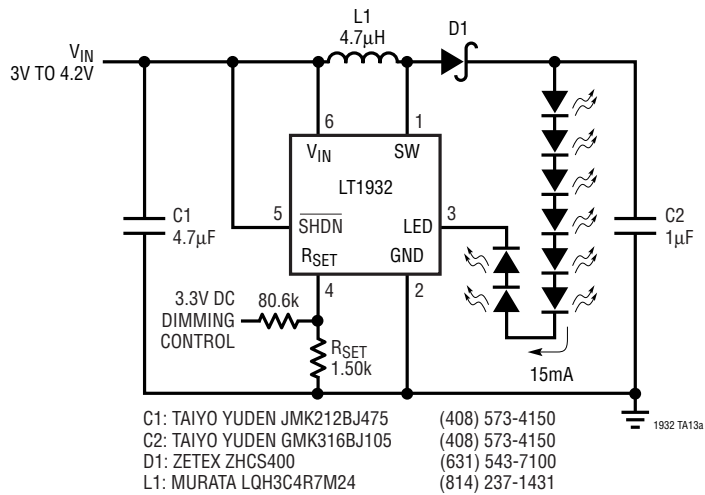

Efficiency

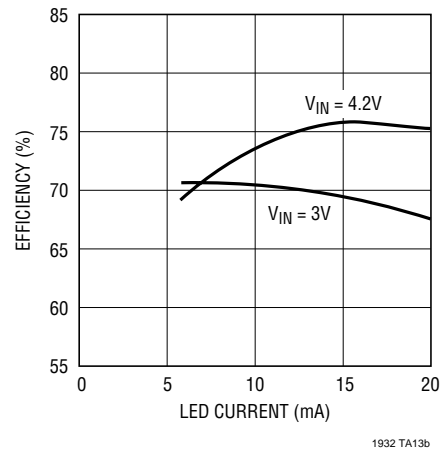

# PACKAGE DESCRIPTION

**S6 Package**  
**6-Lead Plastic SOT-23**  
 (LTC DWG # 05-08-1634)  
 (LTC DWG # 05-08-1636)

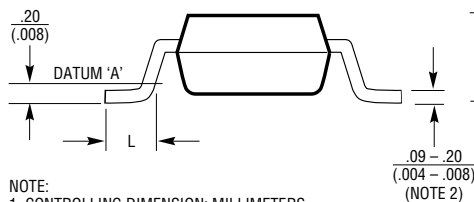

- NOTE:
1. CONTROLLING DIMENSION: MILLIMETERS
  2. DIMENSIONS ARE IN MILLIMETERS (INCHES)
  3. DRAWING NOT TO SCALE
  4. DIMENSIONS ARE INCLUSIVE OF PLATING
  5. DIMENSIONS ARE EXCLUSIVE OF MOLD FLASH AND METAL BURR
  6. MOLD FLASH SHALL NOT EXCEED .254mm
  7. PACKAGE EIAJ REFERENCE IS: SC-74A (EIAJ) FOR ORIGINAL JEDEL MO-193 FOR THIN

	SOT-23 (Original)	SOT-23 (ThinSOT)
A	.90 - 1.45 (.035 - .057)	1.00 MAX (.039 MAX)
A1	.00 - 0.15 (.00 - .006)	.01 - .10 (.0004 - .004)
A2	.90 - 1.30 (.035 - .051)	.80 - .90 (.031 - .035)
L	.35 - .55 (.014 - .021)	.30 - .50 REF (.012 - .019 REF)

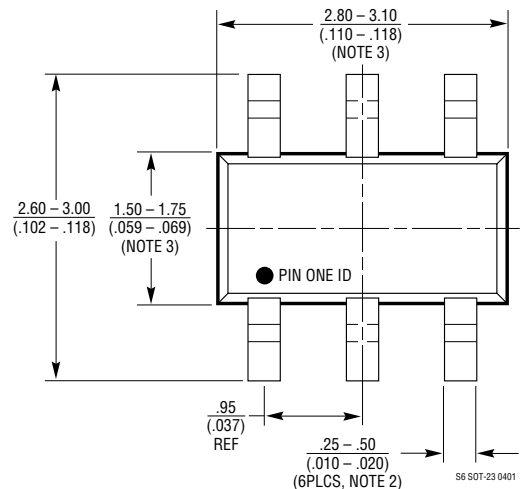

# LT1932

## TYPICAL APPLICATION

### Li-Ion Driver for Ten White LEDs

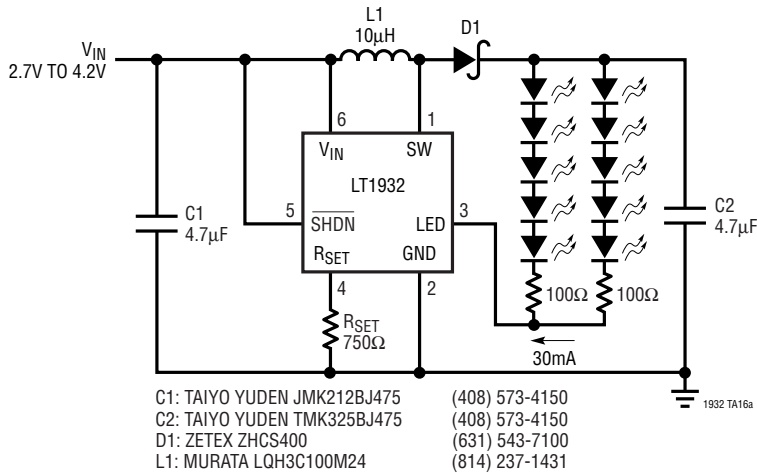

### Efficiency

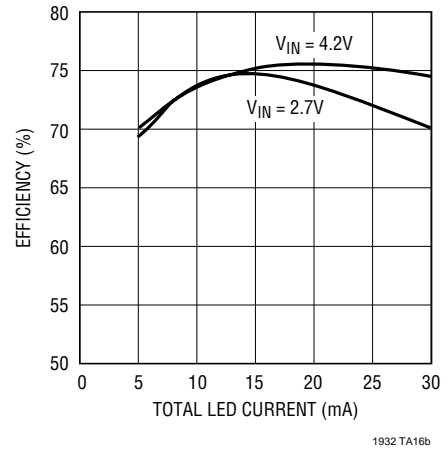

### Li-Ion Driver for Six White LEDs

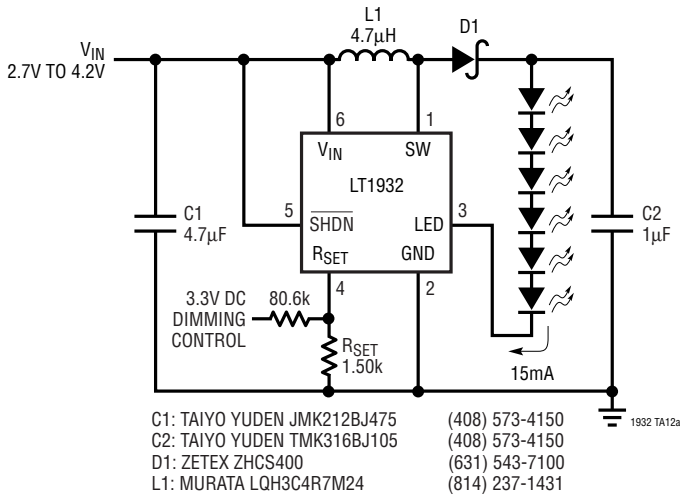

### Efficiency

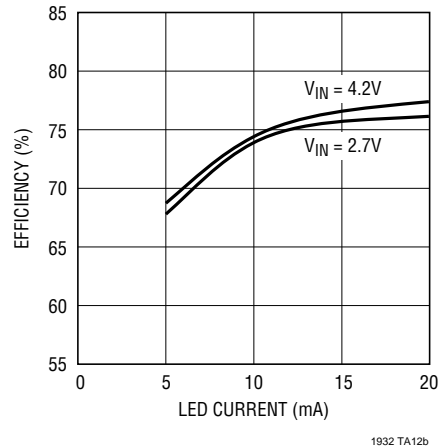

## RELATED PARTS

PART NUMBER	DESCRIPTION	COMMENTS
LT1615	Micropower DC/DC Converter in 5-Lead ThinSOT	20V at 12mA from 2.5V Input, ThinSOT Package
LT1617	Micropower Inverting DC/DC Converter in 5-Lead ThinSOT	-15V at 12mA from 2.5V Input, ThinSOT Package
LT1618	Constant-Current/Constant-Voltage DC/DC Converter	Drives 20 White LEDs from Li-Ion, MS10 Package
LTC1682	Doubler Charge Pump with Low Noise Linear Regulator	3.3V and 5V Outputs with 60µV <sub>RMS</sub> Noise, Up to 80mA Output
LT1930	1.4MHz Switching Regulator in 5-Lead ThinSOT	5V at 480mA from 3.3V Input, ThinSOT Package
LT1931	Inverting 1.2MHz Switching Regulator in 5-Lead ThinSOT	-5V at 350mA from 5V Input, ThinSOT Package
LTC3200	Low Noise Regulated Charge Pump	5V Output with Up to 100mA Output