

Eight Input Multiplexer with Control Register

DISTINCTIVE CHARACTERISTICS

- High speed eight-input multiplexer
- On-chip Multiplexer Select and Polarity Control Register
- Output polarity control for inverting or non-inverting output
- Three-state output for expansion
- Common register enable, asynchronous register clear
- AC parameters specified over operating temperature and power supply ranges

GENERAL DESCRIPTION

The Am2922 is an eight-input Multiplexer with Control Register. The device features high speed from clock to output and is intended for use in high speed computer control units or structured state machine designs.

The Am2922 contains an internal register which holds the A, B and C multiplexer select lines as well as the POL (Polarity) control bit. When the Register Enable input (RE) is LOW, new data is entered into the register on the LOW-to-HIGH transition of the clock. When RE is HIGH, the register retains its current data. An asynchronous clear input (CLR) is used to reset the register to a logic LOW level.

The A, B and C register outputs select one of eight multiplexer data inputs. A HIGH on the Polarity Control flip-

flop output causes a true (non-inverting) multiplexer output, and a LOW causes the output to be inverted. In a computer control unit, this allows testing of either true or complemented flag data at the microprogram sequencer test input.

An active LOW Multiplexer Enable input (\overline{ME}) allows the selected multiplexer input to be passed to the output. When \overline{ME} is HIGH, the output is determined only by the Polarity Control bit.

The Am2922 also features a three-state Output Enable control (\overline{OE}) for expansion. When \overline{OE} is LOW, the output is enabled. When \overline{OE} is HIGH, the output is in the high impedance state.

BLOCK DIAGRAM

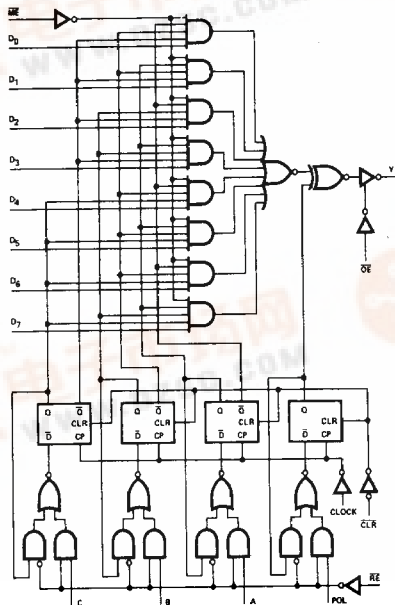

BD002410



CONNECTION DIAGRAM Top View

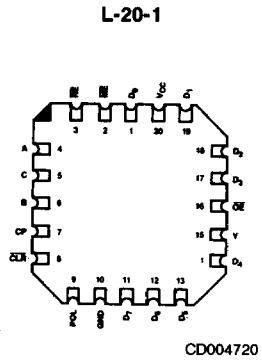
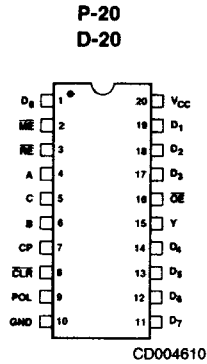

Note: Pin 1 is marked for orientation
F-20 pin configuration identical to D-20, P-20.

LOGIC SYMBOL

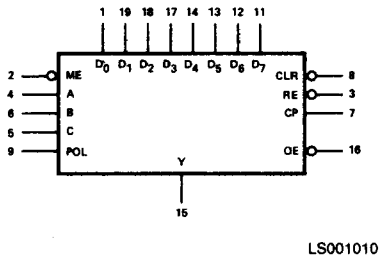

METALLIZATION AND PAD LAYOUT

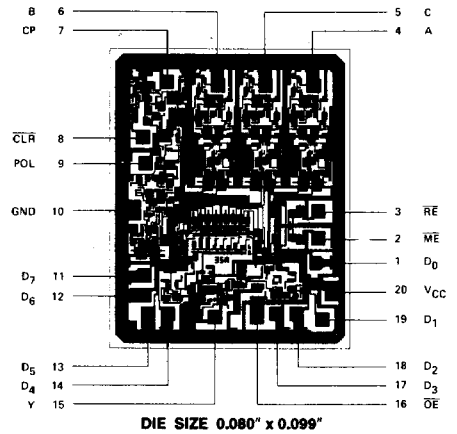

ORDERING INFORMATION

AMD products are available in several packages and operating ranges. The order number is formed by a combination of the following: Device number, speed option (if applicable), package type, operating range and screening option (if desired).

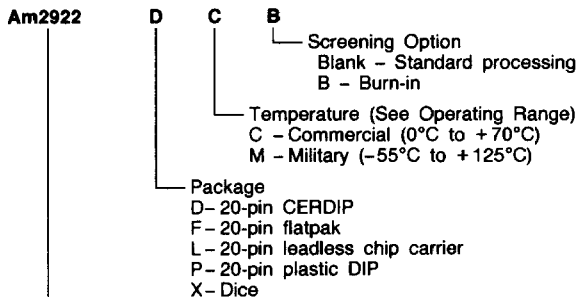

Device type
8-Input Multiplexer

Valid Combinations	
Am2922	PC DC, DCB, DM, DMB FM, FMB LC, LCB, LM, LMB XC, XM

Valid Combinations
Consult the AMD sales office in your area to determine if a device is currently available in the combination you wish.

PIN DESCRIPTION

Pin No.	Name	I/O	Description
4, 6, 5	A, B, C	I	Multiplexer Select Lines. One of eight multiplexer data inputs is selected by the A, B and C register outputs.
9	POL	I	Polarity Control Bit. A HIGH register output causes a true (non-inverted) output and a LOW causes the output to be inverted.
2	ME	I	Multiplexer Enable. When LOW, it enabled the 8-input multiplexer. When HIGH, the Y output is determined by only the Polarity Control bit.
3	RE	I	Register Enable. When LOW, the Multiplexer Select and Polarity Control Register is enabled for loading. When HIGH, the register holds its current data.
8	CLR	I	Clear. A LOW asynchronously resets the Multiplexer Select and Polarity Control Register.
	D ₁ -D ₈	I	Data Inputs to the 8-input multiplexer.
7	CP	I	Clock Pulse. When RE is LOW, the Multiplexer Select and Polarity Control Register changes state on the LOW-to-HIGH transition of CP.
16	OE	I	Output Enable. When LOW, the output is enabled. When HIGH, the output is in the high impedance state.
15	Y	O	The chip output.

FUNCTION TABLE

MODE	INPUTS							INTERNAL				INPUTS		OUTPUT
	C	B	A	POL	RE	CLR	CP	Q _C	Q _B	Q _A	Q _{POL}	ME	OE	Y
Clear	X ↓	X ↓	X ↓	X ↓	X ↓	L ↓	X ↓	L ↓	L ↓	L ↓	L ↓	H L X	L L H	H D ₀ Z
Reg. Disable	X	X	X	X	H	H	X	NC	NC	NC	NC	L	L	D ₇ /D ₁ (Note 1)
Select (Multiplex)	L L L L H H H H	L L H H L L H H	L H L L L L H H	L/H ↓	L ↓	H ↓	↑ ↓	L L L L H H H	L H H L L H H	L L H L L L H	L/H ↓	L ↓	L ↓	D ₀ /D ₀ D ₁ /D ₁ D ₂ /D ₂ D ₃ /D ₃ D ₄ /D ₄ D ₅ /D ₅ D ₆ /D ₆ D ₇ /D ₇
Multiplexer Disable	X ↓	X ↓	X ↓	X ↓	X ↓	H ↓	X ↓	X X	X X	X X	L H	H H	L L	H L
Tri-state Output Disable	↓	↓	↓	↓	↓	↓	↓	X	X	X	X	X	H	Z

NC = No Change
 X = Don't Care
 H = High
 L = Low
 ↑ = Low-to-High Transition
 Z = High-Impedance

Note 1: The output will follow the selected input, D_i, or its complement depending on the state of the POL flip-flop.

APPLICATIONS

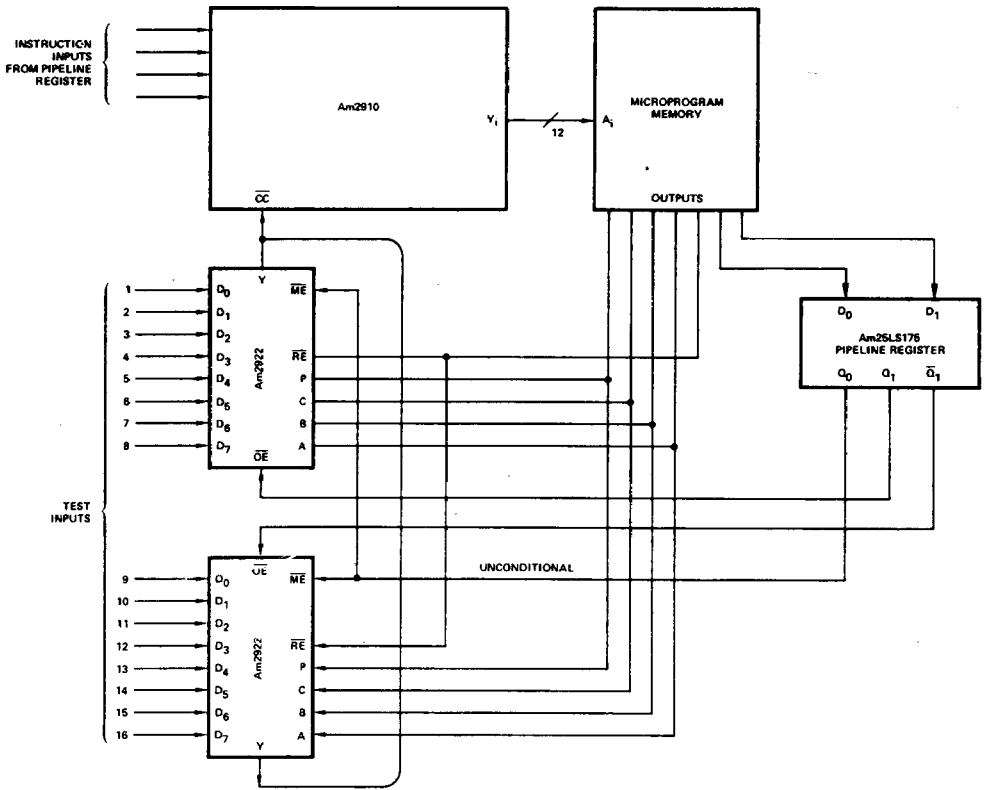

AF001840

A versatile one-of-sixteen Test Select with Polarity Control and Test Select Hold.

ABSOLUTE MAXIMUM RATINGS

Storage Temperature	-65°C to +150°C
(Ambient) Temperature Under Bias	-55°C to +125°C
Supply Voltage to Ground Potential	
Continuous	-0.5V to +7.0V
DC Voltage Applied to Outputs For	
High Output State	-0.5V to +V _{CC} max
DC Input Voltage	-0.5V to +5.5V
DC Output Current, into Outputs	30mA
DC Input Current	-30mA to +5.0mA

Stresses above those listed under ABSOLUTE MAXIMUM RATINGS may cause permanent device failure. Functionality at or above these limits is not implied. Exposure to absolute maximum ratings for extended periods may affect device reliability.

OPERATING RANGES

Commercial (C) Devices	
Temperature	0°C to +70°C
Supply Voltage	+4.75V to +5.25V
Military (M) Devices	
Temperature	-55°C to +125°C
Supply Voltage	+4.5V to +5.5V

Operating ranges define those limits over which the functionality of the device is guaranteed.

DC CHARACTERISTICS over operating range unless otherwise specified

Parameters	Description	Test Conditions (Note 2)	Min	Typ (Note 1)	Max	Units
V _{OH}	Output HIGH Voltage	V _{CC} = MIN V _{IN} = V _{IH} or V _{IL}	MIL, I _{OH} = -2.0mA COM'L, I _{OH} = -6.5mA	2.4 2.4	3.4 3.2	Volts
V _{OL}	Output LOW Voltage	V _{CC} = MIN V _{IN} = V _{IH} or V _{IL}	I _{OL} = 4.0mA I _{OL} = 8.0mA I _{OL} = 20mA		0.4 0.45 0.5	Volts
V _{IH}	Input HIGH Level	Guaranteed input logical HIGH voltage for all inputs		2.0		Volts
V _{IL}	Input LOW Level	Guaranteed input logical LOW voltage for all inputs	MIL COM'L	0.8	0.7	Volts
V _I	Input Clamp Voltage	V _{CC} = MIN, I _{IN} = -18mA			-1.5	Volts
I _{IL}	Input LOW Current	V _{CC} = MAX, V _{IN} = 0.4V	ME, OE, RE DN, A, B, C, POL, CP, CLR		-0.72 -2.0	mA
I _{IH}	Input HIGH Current	V _{CC} = MAX, V _{IN} = 2.7V	ME, OE, RE DN, A, B, C, POL, CP, CLR		40 50	μ
I _I	Input HIGH Current	V _{CC} = MAX, V _{IN} = 5.5V	ME, OE, RE DN, A, B, C, POL, CP, CLR		0.1 1.0	mA
I _{OZ}	Off-State (High-Impedance) Output Current	V _{CC} = MAX	V _O = 0.4V V _O = 2.4V		-50 50	μA
I _{SC}	Output Short Circuit Current (Note 3)	V _{CC} = MAX		-40	-100	mA
I _{CC}	Power Supply Current (Note 4)	V _{CC} = MAX		97	148	mA

- Notes: 1. Typical limits are at V_{CC} = 5.0V, 25°C ambient and maximum loading.
 2. For conditions shown as MIN or MAX, use the appropriate value specified under Operating Ranges for the applicable device type.
 3. Not more than one output should be shorted at a time. Duration of the short circuit test should not exceed one second.
 4. DN, A, B, C, POL, ME at Gnd. All other inputs and outputs open. Measured after a momentary ground then 4.5V applied to clock input.

SWITCHING CHARACTERISTICS ($T_A = +25^\circ\text{C}$, $V_{CC} = 5.0\text{V}$)

Parameters	Description	Test Conditions	Min	Typ	Max	Units	
t _{PLH}	Clock to Y POL - LOW	$C_L = 15\text{pF}$ $R_L = 2.0\text{k}\Omega$		21	32	ns	
t _{PHL}				19	29		
t _{PLH}	Clock to Y POL - HIGH			16	24	ns	
t _{PHL}				19	29		
t _{PLH}	D _n to Y			10	16	ns	
t _{PHL}				13	19		
t _{PLH}	CLR to Y			22	33	ns	
t _{PHL}				22	33		
t _{PLH}	ME to Y			12	18	ns	
t _{PHL}				12	18		
t _{ZL}	OE to Y		$C_L = 5.0\text{pF}$ $R_L = 2.0\text{k}\Omega$		8	14	ns
t _{ZH}					8	14	
t _{LZ}					10	17	
t _{HZ}					10	17	
t _s	A, B, C, POL	$C_L = 15\text{pF}$ $R_L = 2.0\text{k}\Omega$		10			ns
	CE			15			
t _s	CLR Recovery			5			ns
t _{pw}	Clock			10			ns
	Clear (LOW)		10				
t _h	A, B, C, POL, CE		0			ns	

SWITCHING CHARACTERISTICS over operating range unless otherwise specified*

Parameters	Description	Test Conditions	COMMERCIAL Am2922		MILITARY Am2922		Units	
			Min	Max	Min	Max		
t _{PLH}	Clock to Y POL - LOW	$C_L = 50\text{pF}$ $R_L = 2.0\text{k}\Omega$		40		47	ns	
t _{PHL}				34		38		
t _{PLH}	Clock to Y POL - HIGH			29		33	ns	
t _{PHL}				35		41		
t _{PLH}	D _n to Y			19		21	ns	
t _{PHL}				22		24		
t _{PLH}	CLR to Y			39		45	ns	
t _{PHL}				39		45		
t _{PLH}	ME to Y			22		26	ns	
t _{PHL}				19		20		
t _{ZL}	OE to Y		$C_L = 5.0\text{pF}$ $R_L = 2.0\text{k}\Omega$		19		24	ns
t _{ZH}					22		29	
t _{LZ}					24		30	
t _{HZ}					24		30	
t _s	A, B, C, POL	$C_L = 50\text{pF}$ $R_L = 2.0\text{k}\Omega$		11		12	ns	
	CE			18		20		
t _s	CLR Recovery			6		7	ns	
t _{pw}	Clock			11		12	ns	
	Clear (LOW)		11		12			
t _h	A, B, C, POL, CE		3		3	ns		

*Switching Characteristics' performance over the operating temperature range is guaranteed by testing defined in Group A, Subgroup 9.

LOW-POWER SCHOTTKY INPUT/OUTPUT CURRENT INTERFACE CONDITIONS

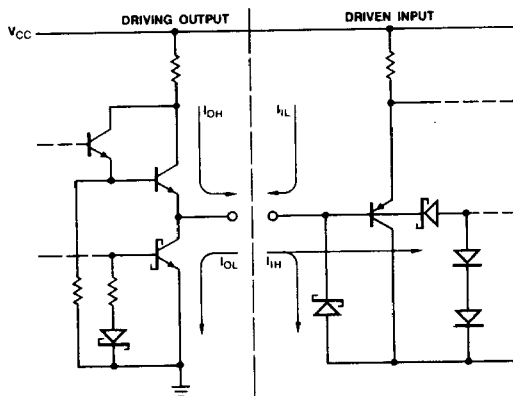

IC000381

Note: Actual current flow direction shown.

5

RELATED PRODUCTS

Part No.	Description
Am25LS2535	8-Input Multiplexer
Am2923	8-Input Multiplexer