

# TLC372, TLC372Q, TLC372Y LinCMOS™ DUAL DIFFERENTIAL COMPARATORS

SLCS114B – NOVEMBER 1983 – REVISED MARCH 1999

- **Single or Dual-Supply Operation**
- **Wide Range of Supply Voltages**  
2 V to 18 V
- **Very Low Supply Current Drain**  
150  $\mu$ A Typ at 5 V
- **Fast Response Time . . . 200 ns Typ for TTL-Level Input Step**
- **Built-in ESD Protection**
- **High Input Impedance . . .  $10^{12} \Omega$  Typ**
- **Extremely Low Input Bias Current**  
5 pA Typ
- **Ultrastable Low Input Offset Voltage**
- **Input Offset Voltage Change at Worst-Case Input Conditions Typically 0.23  $\mu$ V/Month, Including the First 30 Days**
- **Common-Mode Input Voltage Range Includes Ground**
- **Output Compatible With TTL, MOS, and CMOS**
- **Pin-Compatible With LM393**

## description

This device is fabricated using LinCMOS™ technology and consists of two independent voltage comparators, each designed to operate from a single power supply. Operation from dual supplies is also possible if the difference between the two supplies is 2 V to 18 V. Each device features extremely high input impedance (typically greater than  $10^{12} \Omega$ ), allowing direct interfacing with high-impedance sources. The outputs are n-channel open-drain configurations and can be connected to achieve positive-logic wired-AND relationships.

The TLC372 has internal electrostatic discharge (ESD) protection circuits and has been classified with a 1000-V ESD rating using human body model testing. However, care should be exercised in handling this device as exposure to ESD may result in a degradation of the device parametric performance.

The TLC372C is characterized for operation from 0°C to 70°C. The TLC372I is characterized for operation from –40°C to 85°C. The TLC372M is characterized for operation over the full military temperature range of –55°C to 125°C. The TLC372Q is characterized for operation from –40°C to 125°C.

TLC372C, TLC372I, TLC372M, TLC372Q  
D, P, OR PW PACKAGE  
TLC372M . . . JG PACKAGE  
(TOP VIEW)

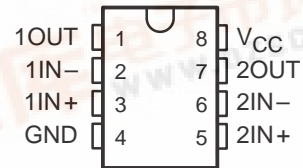

TLC372M . . . FK PACKAGE  
(TOP VIEW)

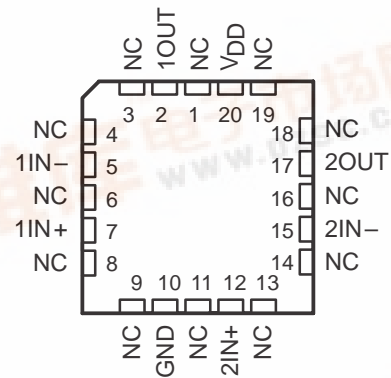

NC – No internal connection

## symbol (each comparator)

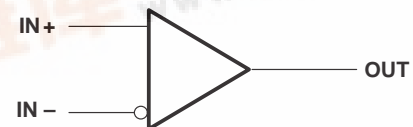

Please be aware that an important notice concerning availability, standard warranty, and use in critical applications of Texas Instruments semiconductor products and disclaimers thereto appears at the end of this data sheet.

LinCMOS is a trademark of Texas Instruments Incorporated.

PRODUCTION DATA information is current as of publication date. Products conform to specifications per the terms of Texas Instruments standard warranty. Production processing does not necessarily include testing of all parameters.

# TLC372, TLC372Q, TLC372Y LinCMOS™ DUAL DIFFERENTIAL COMPARATORS

SLCS114B – NOVEMBER 1983 – REVISED MARCH 1999

## equivalent schematic (each comparator)

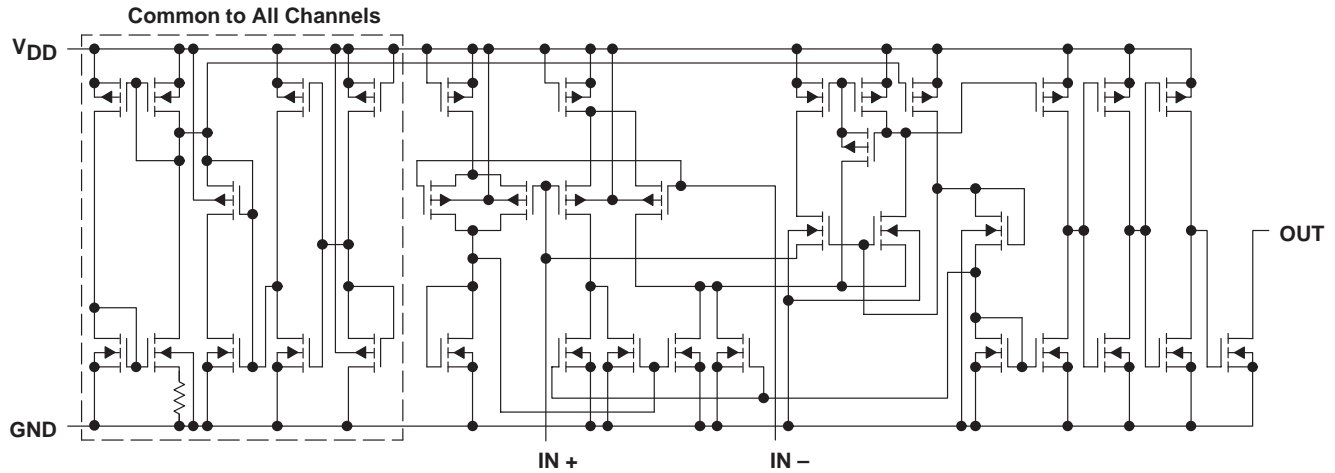

### AVAILABLE OPTIONS

T <sub>A</sub>	V <sub>IO</sub> max AT 25°C	PACKAGED DEVICES					CHIP FORM (Y)
		SMALL OUTLINE (D)	CHIP CARRIER (FK)	CERAMIC DIP (JG)	PLASTIC DIP (P)	TSSOP (PW)	
0°C to 70°C	5 mV	TLC372CD	—	—	TLC372CP	TLC372CPW	TLC372Y
-40°C to 85°C	5 mV	TLC372ID	—	—	TLC372IP	—	—
-55°C to 125°C	5 mV	TLC372MD	TLC372MFK	TLC372MJG	TLC372MP	—	—
-40°C to 125°C	5 mV	TLC372QD	—	—	TLC372QP	—	—

The D packages are available taped and reeled. Add R suffix to device type (e.g., TLC372CDR).

# TLC372, TLC372Q, TLC372Y LinCMOS™ DUAL DIFFERENTIAL COMPARATORS

SLCS114B – NOVEMBER 1983 – REVISED MARCH 1999

## TLC372Y chip information

These chips, when properly assembled, display characteristics similar to the TLC372C. Thermal compression or ultrasonic bonding can be used on the doped-aluminum bonding pads. Chips can be mounted with conductive epoxy or a gold-silicon preform.

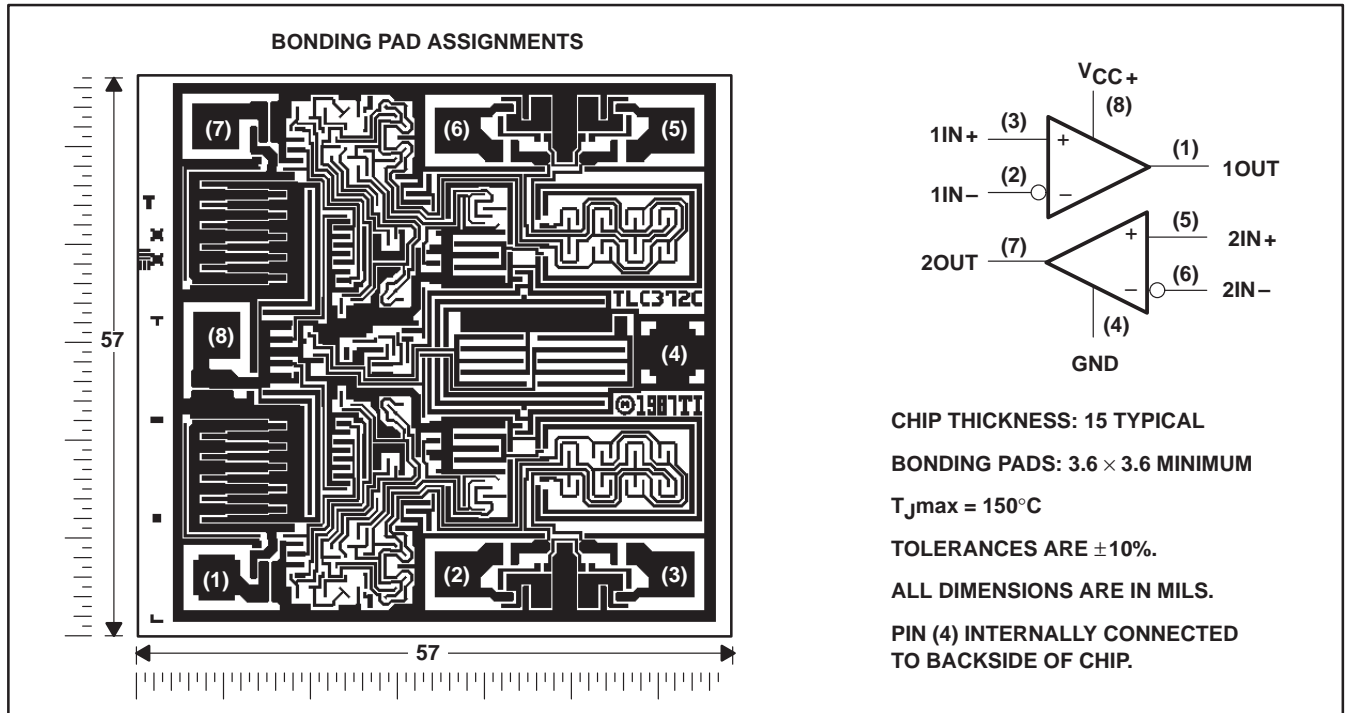

# TLC372, TLC372Q, TLC372Y LinCMOS™ DUAL DIFFERENTIAL COMPARATORS

SLCS114B – NOVEMBER 1983 – REVISED MARCH 1999

## absolute maximum ratings over operating free-air temperature range (unless otherwise noted)†

Supply voltage, $V_{DD}$ (see Note 1)	18 V
Differential input voltage, $V_{ID}$ (see Note 2)	$\pm 18$ V
Input voltage range, $V_I$	-0.3 V to 18 V
Output voltage, $V_O$	18 V
Input current, $I_I$	$\pm 5$ mA
Output current, $I_O$	20 mA
Duration of output short circuit to ground (see Note 3)	unlimited
Continuous total power dissipation	See Dissipation Rating Table
Operating free-air temperature range, $T_A$ : TLC372C	0°C to 70°C
TLC372I	-40°C to 85°C
TLC372M	-55°C to 125°C
TLC372Q	-40°C to 125°C
Storage temperature range	-65°C to 150°C
Case temperature for 60 seconds: FK package	260°C
Lead temperature 1,6 mm (1/16 inch) from case for 10 seconds: D, P, or PW package	260°C
Lead temperature 1,6 mm (1/16 inch) from case for 60 seconds: JG package	300°C

† Stresses beyond those listed under “absolute maximum ratings” may cause permanent damage to the device. These are stress ratings only, and functional operation of the device at these or any other conditions beyond those indicated under “recommended operating conditions” is not implied. Exposure to absolute-maximum-rated conditions for extended periods may affect device reliability.

- NOTES: 1. All voltage values except differential voltages are with respect to network ground.  
 2. Differential voltages are at  $IN+$  with respect to  $IN-$ .  
 3. Short circuits from outputs to  $V_{DD}$  can cause excessive heating and eventual device destruction.

DISSIPATION RATING TABLE

PACKAGE	$T_A \leq 25^\circ\text{C}$ POWER RATING	DERATING FACTOR	DERATE ABOVE $T_A$	$T_A = 70^\circ\text{C}$ POWER RATING	$T_A = 85^\circ\text{C}$ POWER RATING	$T_A = 125^\circ\text{C}$ POWER RATING
D	500 mW	5.8 mW/°C	64°C	464 mW	377 mW	145 mW
FK	500 mW	11.0 mW/°C	104°C	500 mW	500 mW	275 mW
JG	500 mW	8.4 mW/°C	90°C	500 mW	500 mW	210 mW
P	500 mW	8.0 mW/°C	87°C	500 mW	500 mW	200 mW
PW	525 mW	4.2 mW/°C	25°C	336 mW	N/A	N/A

## recommended operating conditions

	TLC372C		TLC372I		TLC372M		TLC372Q		UNIT
	MIN	MAX	MIN	MAX	MIN	MAX	MIN	MAX	
Supply voltage, $V_{DD}$	3	16	3	16	4	16	4	16	V
Common-mode input voltage, $V_{IC}$	$V_{DD} = 5$ V		0	3.5	0	3.5	0	3.5	V
	$V_{DD} = 10$ V		0	8.5	0	8.5	0	8.5	
Operating free-air temperature, $T_A$	0	70	-40	85	-55	125	-40	125	°C

# TLC372, TLC372Q, TLC372Y

## LinCMOS™ DUAL DIFFERENTIAL COMPARATORS

SLCS114B – NOVEMBER 1983 – REVISED MARCH 1999

### electrical characteristics at specified free-air temperature, $V_{DD} = 5\text{ V}$ (unless otherwise noted)

PARAMETER	TEST CONDITIONS	T <sub>A</sub> †	TLC372C			TLC372I			TLC372M, TLC372Q			UNIT
			MIN	TYP	MAX	MIN	TYP	MAX	MIN	TYP	MAX	
V <sub>IO</sub> Input offset voltage	V <sub>IC</sub> = V <sub>ICRmin</sub> , See Note 4	25°C	1	5	5	1	5	5	1	5	5	mV
			Full range			6.5	7	10				
I <sub>IO</sub> Input offset current		25°C	1			1			1		pA	
I <sub>IB</sub> Input bias current		25°C	0.3			1			5		10	nA
			MAX			0.6	2	20				
V <sub>ICR</sub> Common-mode input voltage range		25°C	0 to V <sub>DD</sub> -1			0 to V <sub>DD</sub> -1			0 to V <sub>DD</sub> -1		V	
			Full range			0 to V <sub>DD</sub> -1.5	0 to V <sub>DD</sub> -1.5					
I <sub>OH</sub> High-level output current	V <sub>ID</sub> = 1 V	25°C	0.1			0.1			0.1		nA	
			Full range			1	3					
V <sub>OL</sub> Low-level output voltage	V <sub>ID</sub> = -1 V, I <sub>OL</sub> = 4 mA	25°C	150	400	400	150	400	400	150	400	mV	
			Full range			700	700					
I <sub>OL</sub> Low-level output current	V <sub>ID</sub> = -1 V, V <sub>OL</sub> = 1.5 V	25°C	6	16	16	6	16	16	6	16	mA	
			Full range			300	300					
I <sub>DD</sub> Supply current (two comparators)	V <sub>ID</sub> = 1 V, No load	25°C	150	300	300	150	300	300	150	300	μA	
			Full range			400	400					

† All characteristics are measured with zero common-mode input voltage unless otherwise noted. Full range is 0°C to 70°C for TLC372C, -40°C to 85°C for TLC372I, and -55°C to 125°C for TLC372M and -40°C to 125°C for TLC372Q. IMPORTANT: See Parameter Measurement Information.

NOTE 4: The offset voltage limits given are the maximum values required to drive the output above 4 V or below 400 mV with a 10-kΩ resistor between the output and V<sub>DD</sub>. They can be verified by applying the limit value to the input and checking for the appropriate output state.

### switching characteristics, $V_{DD} = 5\text{ V}$ , T<sub>A</sub> = 25°C

PARAMETER	TEST CONDITIONS	MIN	TYP	MAX	UNIT
Response time	R <sub>L</sub> connected to 5 V through 5.1 kΩ, C <sub>L</sub> = 15 pF‡, See Note 5	100-mV input step with 5-mV overdrive			ns
		TTL-level input step			

‡ C<sub>L</sub> includes probe and jig capacitance.

NOTE 5: The response time specified is the interval between the input step function and the instant when the output crosses 1.4 V.

# TLC372, TLC372Q, TLC372Y

## LinCMOS™ DUAL DIFFERENTIAL COMPARATORS

SLCS114B – NOVEMBER 1983 – REVISED MARCH 1999

electrical characteristics at specified free-air temperature,  $V_{DD} = 5\text{ V}$ ,  $T_A = 25^\circ\text{C}$  (unless otherwise noted)

PARAMETER	TEST CONDITIONST	TLC372Y			UNIT
		MIN	TYP	MAX	
$V_{IO}$ Input offset voltage	$V_{IC} = V_{ICRmin}$ , See Note 4		1	5	mV
$I_{IO}$ Input offset current			1		pA
$I_{IB}$ Input bias current			5		pA
$V_{ICR}$ Common-mode input voltage range			0 to $V_{DD}-1$		V
$I_{OH}$ High-level output current	$V_{ID} = 1\text{ V}$ , $V_{OH} = 5\text{ V}$		0.1		nA
$V_{OL}$ Low-level output voltage	$V_{ID} = -1\text{ V}$ , $I_{OL} = 4\text{ mA}$		150	400	mV
$I_{OL}$ Low-level output current	$V_{ID} = -1\text{ V}$ , $V_{OL} = 1.5\text{ V}$	6	16		mA
$I_{DD}$ Supply current (two comparators)	$V_{ID} = 1\text{ V}$ , No load		150	300	$\mu\text{A}$

† All characteristics are measured with zero common-mode input voltage unless otherwise noted. IMPORTANT: See Parameter Measurement Information.

NOTE 4: The offset voltage limits given are the maximum values required to drive the output above 4 V or below 400 mV with a 10-k $\Omega$  resistor between the output and  $V_{DD}$ . They can be verified by applying the limit value to the input and checking for the appropriate output state.

### PARAMETER MEASUREMENT INFORMATION

The digital output stage of the TLC372 can be damaged if it is held in the linear region of the transfer curve. Conventional operational amplifier/comparator testing incorporates the use of a servo loop that is designed to force the device output to a level within this linear region. Since the servo-loop method of testing cannot be used, the following alternatives for measuring parameters such as input offset voltage, common-mode rejection, etc., are offered.

To verify that the input offset voltage falls within the limits specified, the limit value is applied to the input as shown in Figure 1(a). With the noninverting input positive with respect to the inverting input, the output should be high. With the input polarity reversed, the output should be low.

A similar test can be made to verify the input offset voltage at the common-mode extremes. The supply voltages can be slewed as shown in Figure 1(b) for the  $V_{ICR}$  test, rather than changing the input voltages, to provide greater accuracy.

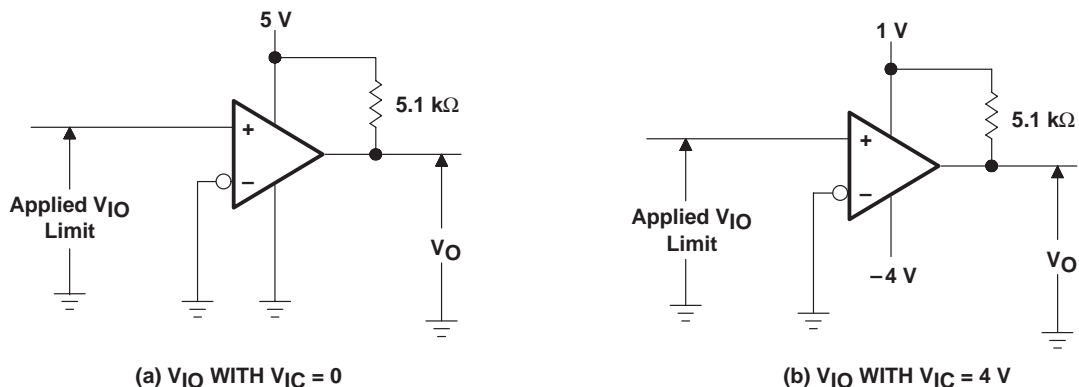

Figure 1. Method for Verifying That Input Offset Voltage is Within Specified Limits

PARAMETER MEASUREMENT INFORMATION

A close approximation of the input offset voltage can be obtained by using a binary search method to vary the differential input voltage while monitoring the output state. When the applied input voltage differential is equal, but opposite in polarity, to the input offset voltage, the output changes states.

Figure 2 illustrates a practical circuit for direct dc measurement of input offset voltage that does not bias the comparator into the linear region. The circuit consists of a switching-mode servo loop in which U1a generates a triangular waveform of approximately 20-mV amplitude. U1b acts as a buffer, with C2 and R4 removing any residual dc offset. The signal is then applied to the inverting input of the comparator under test, while the noninverting input is driven by the output of the integrator formed by U1c through the voltage divider formed by R9 and R10. The loop reaches a stable operating point when the output of the comparator under test has a duty cycle of exactly 50%, which can only occur when the incoming triangle wave is sliced symmetrically or when the voltage at the noninverting input exactly equals the input offset voltage.

Voltage divider R9 and R10 provides a step up of the input offset voltage by a factor of 100 to make measurement easier. The values of R5, R8, R9, and R10 can significantly influence the accuracy of the reading; therefore, it is suggested that their tolerance level be 1% or lower.

Measuring the extremely low values of input current requires isolation from all other sources of leakage current and compensation for the leakage of the test socket and board. With a good picoammeter, the socket and board leakage can be measured with no device in the socket. Subsequently, this open-socket leakage value can be subtracted from the measurement obtained with a device in the socket to obtain the actual input current of the device.

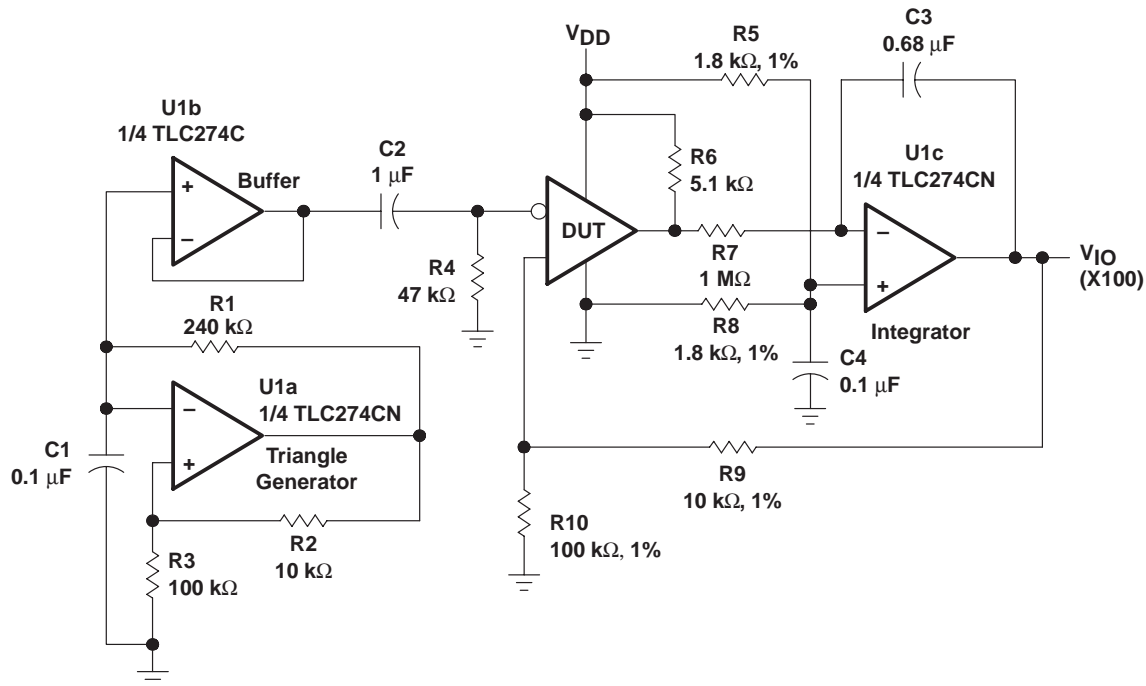

Figure 2. Circuit for Input Offset Voltage Measurement

# TLC372, TLC372Q, TLC372Y LinCMOS™ DUAL DIFFERENTIAL COMPARATORS

SLCS114B – NOVEMBER 1983 – REVISED MARCH 1999

## PARAMETER MEASUREMENT INFORMATION

Response time is defined as the interval between the application of an input step function and the instant when the output reaches 50% of its maximum value. Response time, low-to-high-level output, is measured from the leading edge of the input pulse, while response time, high-to-low-level output, is measured from the trailing edge of the input pulse. Response-time measurement at low input signal levels can be greatly affected by the input offset voltage. The offset voltage should be balanced by the adjustment at the inverting input as shown in Figure 3, so that the circuit is just at the transition point. Then a low signal, for example 105-mV or 5-mV overdrive, causes the output to change state.

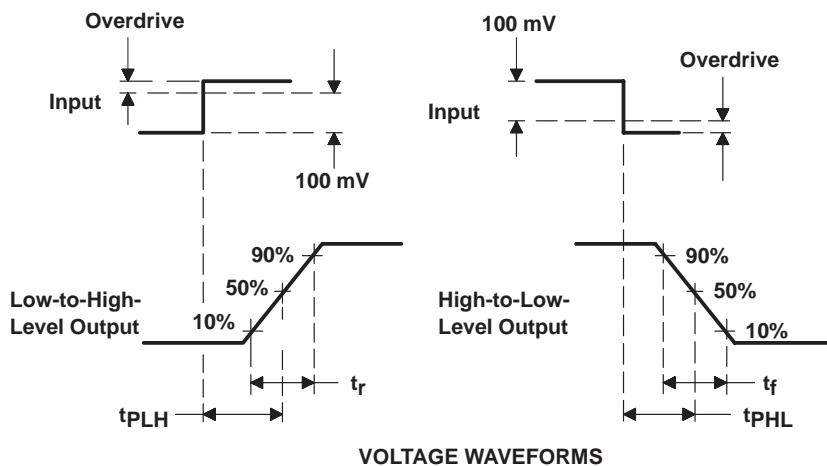
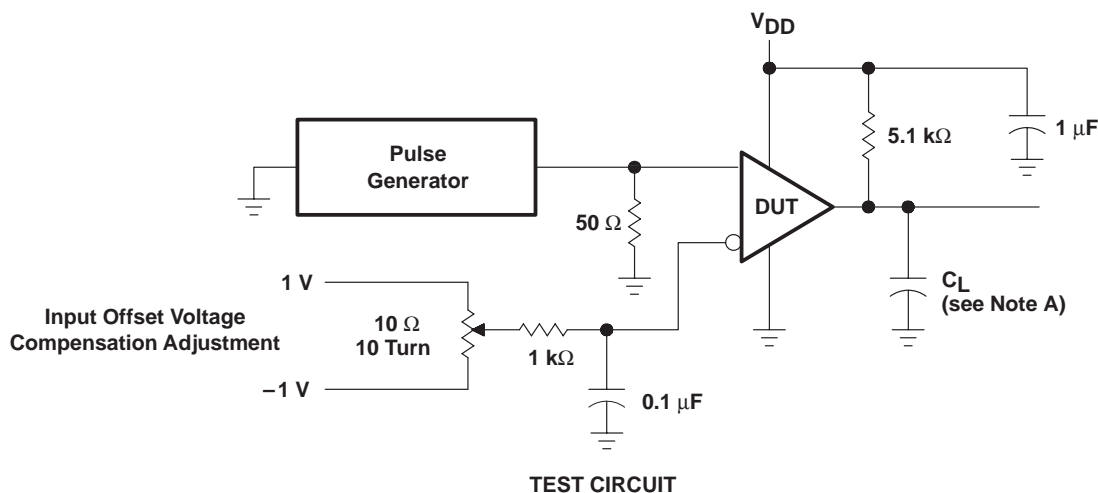

NOTE A:  $C_L$  includes probe and jig capacitance.

Figure 3. Response, Rise, and Fall Times Circuit and Voltage Waveforms



## PRINCIPLES OF OPERATION

### LinCMOS™ process

The LinCMOS™ process is a Linear polysilicon-gate complementary-MOS process. Primarily designed for single-supply applications, LinCMOS™ products facilitate the design of a wide range of high-performance analog functions, from operational amplifiers to complex mixed-mode converters.

While digital designers are experienced with CMOS, MOS technologies are relatively new for analog designers. This short guide is intended to answer the most frequently asked questions related to the quality and reliability of LinCMOS™ products. Further questions should be directed to the nearest TI field sales office.

### electrostatic discharge

CMOS circuits are prone to gate oxide breakdown when exposed to high voltages even if the exposure is only for very short periods of time. Electrostatic discharge (ESD) is one of the most common causes of damage to CMOS devices. It can occur when a device is handled without proper consideration for environmental electrostatic charges, e.g. during board assembly. If a circuit in which one amplifier from a dual operational amplifier is being used and the unused pins are left open, high voltages tends to develop. If there is no provision for ESD protection, these voltages may eventually punch through the gate oxide and cause the device to fail. To prevent voltage buildup, each pin is protected by internal circuitry.

Standard ESD-protection circuits safely shunt the ESD current by providing a mechanism whereby one or more transistors break down at voltages higher than the normal operating voltages but lower than the breakdown voltage of the input gate. This type of protection scheme is limited by leakage currents which flow through the shunting transistors during normal operation after an ESD voltage has occurred. Although these currents are small, on the order of tens of nanoamps, CMOS amplifiers are often specified to draw input currents as low as tens of picoamps.

To overcome this limitation, TI design engineers developed the patented ESD-protection circuit shown in Figure 4. This circuit can withstand several successive 1-kV ESD pulses, while reducing or eliminating leakage currents that may be drawn through the input pins. A more detailed discussion of the operation of TI's ESD-protection circuit is presented on the next page.

All input and output pins on LinCMOS and Advanced LinCMOS™ products have associated ESD-protection circuitry that undergoes qualification testing to withstand 1000 V discharged from a 100-pF capacitor through a 1500-Ω resistor (human body model) and 200 V from a 100-pF capacitor with no current-limiting resistor (charged device model). These tests simulate both operator and machine handling of devices during normal test and assembly operations.

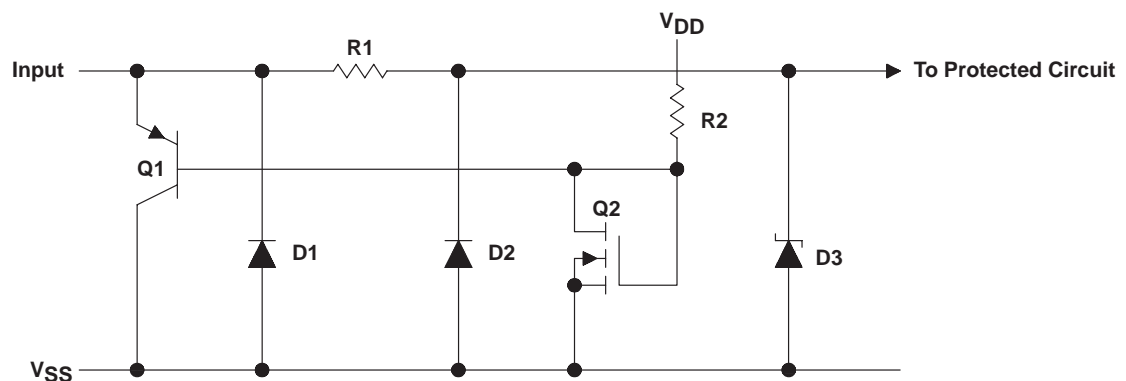

Figure 4. LinCMOS™ ESD-Protection Schematic

# TLC372, TLC372Q, TLC372Y

## LinCMOS™ DUAL DIFFERENTIAL COMPARATORS

SLCS114B – NOVEMBER 1983 – REVISED MARCH 1999

---

### PRINCIPLES OF OPERATION

#### input protection circuit operation

Texas Instruments patented protection circuitry allows for both positive-and negative-going ESD transients. These transients are characterized by extremely fast rise times and usually low energies, and can occur both when the device has all pins open and when it is installed in a circuit.

#### positive ESD transients

Initial positive charged energy is shunted through Q1 to  $V_{SS}$ . Q1 turns on when the voltage at the input rises above the voltage on the  $V_{DD}$  pin by a value equal to the  $V_{EB}$  of Q1. The base current increases through R2 with input current as Q1 saturates. The base current through R2 forces the voltage at the drain and gate of Q2 to exceed its threshold level ( $V_T \sim 22\text{ V to }26\text{ V}$ ) and turn Q2 on. The shunted input current through Q1 to  $V_{SS}$  is now shunted through the n-channel enhancement-type MOSFET Q2 to  $V_{SS}$ . If the voltage on the input pin continues to rise, the breakdown voltage of the zener diode D3 is exceeded, and all remaining energy is dissipated in R1 and D3. The breakdown voltage of D3 is designed to be 24 to 27 V, which is well below the gate oxide voltage of the circuit to be protected.

#### negative ESD transients

The negative charged ESD transients are shunted directly through D1. Additional energy is dissipated in R1 and D2 as D2 becomes forward biased. The voltage seen by the protected circuit is  $-0.3\text{ V to }-1\text{ V}$  (the forward voltage of D1 and D2).

#### circuit-design considerations

LinCMOS™ products are being used in actual circuit environments that have input voltages that exceed the recommended common-mode input voltage range and activate the input protection circuit. Even under normal operation, these conditions occur during circuit power up or power down, and in many cases, when the device is being used for a signal conditioning function. The input voltages can exceed  $V_{ICR}$  and not damage the device only if the inputs are current limited. The recommended current limit shown on most product data sheets is  $\pm 5\text{ mA}$ . Figures 5 and 6 show typical characteristics for input voltage versus input current.

Normal operation and correct output state can be expected even when the input voltage exceeds the positive supply voltage. Again, the input current should be externally limited even though internal positive current limiting is achieved in the input protection circuit by the action of Q1. When Q1 is on, it saturates and limits the current to approximately 5-mA collector current by design. When saturated, Q1 base current increases with input current. This base current is forced into the  $V_{DD}$  pin and into the device  $I_{DD}$  or the  $V_{DD}$  supply through R2 producing the current limiting effects shown in Figure 5. This internal limiting lasts only as long as the input voltage is below the  $V_T$  of Q2.

When the input voltage exceeds the negative supply voltage, normal operation is affected and output voltage states may not be correct. Also, the isolation between channels of multiple devices (duals and quads) can be severely affected. External current limiting must be used since this current is directly shunted by D1 and D2 and no internal limiting is achieved. If normal output voltage states are required, an external input voltage clamp is required (see Figure 7).

# TLC372, TLC372Q, TLC372Y LinCMOS™ DUAL DIFFERENTIAL COMPARATORS

SLCS114B – NOVEMBER 1983 – REVISED MARCH 1999

## PRINCIPLES OF OPERATION

circuit-design considerations (continued)

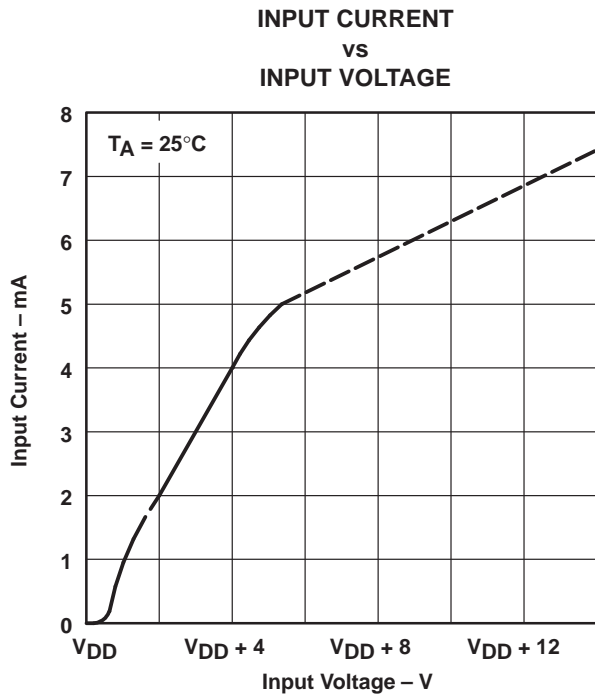

Figure 5

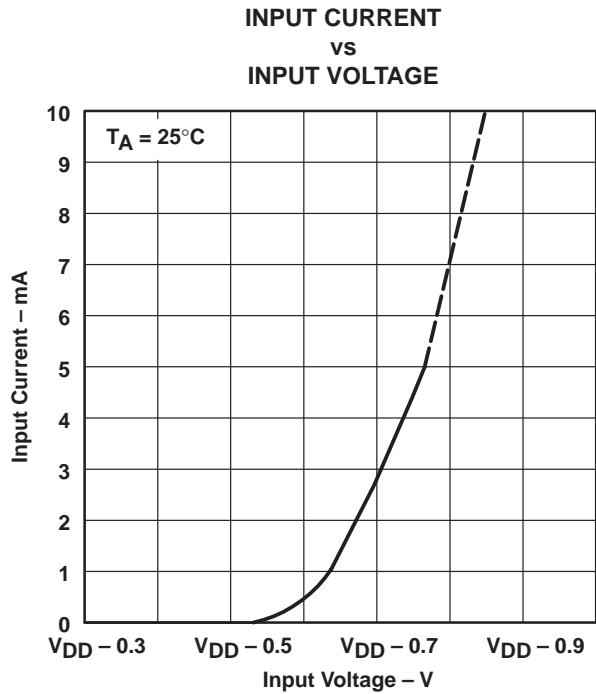
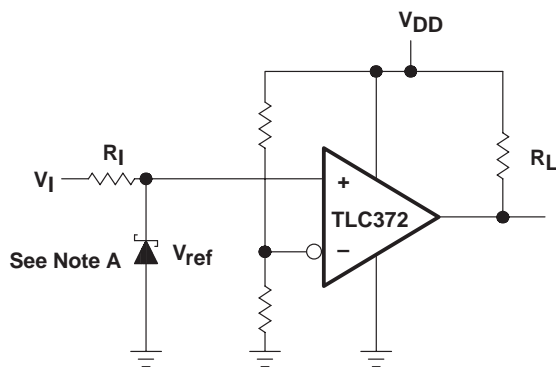

Figure 6



Positive Voltage Input Current Limit:

$$R_I = \frac{+V_I - V_{DD} - 0.3 \text{ V}}{5 \text{ mA}}$$

Negative Voltage Input Current Limit:

$$R_I = \frac{-V_I - V_{DD} - (-0.3 \text{ V})}{5 \text{ mA}}$$

NOTE A: If the correct output state is required when the negative input exceeds  $V_{SS}$ , a schottky clamp is required.

Figure 7. Typical Input Current-Limiting Configuration for a LinCMOS™ Comparator

## **IMPORTANT NOTICE**

Texas Instruments and its subsidiaries (TI) reserve the right to make changes to their products or to discontinue any product or service without notice, and advise customers to obtain the latest version of relevant information to verify, before placing orders, that information being relied on is current and complete. All products are sold subject to the terms and conditions of sale supplied at the time of order acknowledgement, including those pertaining to warranty, patent infringement, and limitation of liability.

TI warrants performance of its semiconductor products to the specifications applicable at the time of sale in accordance with TI's standard warranty. Testing and other quality control techniques are utilized to the extent TI deems necessary to support this warranty. Specific testing of all parameters of each device is not necessarily performed, except those mandated by government requirements.

CERTAIN APPLICATIONS USING SEMICONDUCTOR PRODUCTS MAY INVOLVE POTENTIAL RISKS OF DEATH, PERSONAL INJURY, OR SEVERE PROPERTY OR ENVIRONMENTAL DAMAGE ("CRITICAL APPLICATIONS"). TI SEMICONDUCTOR PRODUCTS ARE NOT DESIGNED, AUTHORIZED, OR WARRANTED TO BE SUITABLE FOR USE IN LIFE-SUPPORT DEVICES OR SYSTEMS OR OTHER CRITICAL APPLICATIONS. INCLUSION OF TI PRODUCTS IN SUCH APPLICATIONS IS UNDERSTOOD TO BE FULLY AT THE CUSTOMER'S RISK.

In order to minimize risks associated with the customer's applications, adequate design and operating safeguards must be provided by the customer to minimize inherent or procedural hazards.

TI assumes no liability for applications assistance or customer product design. TI does not warrant or represent that any license, either express or implied, is granted under any patent right, copyright, mask work right, or other intellectual property right of TI covering or relating to any combination, machine, or process in which such semiconductor products or services might be or are used. TI's publication of information regarding any third party's products or services does not constitute TI's approval, warranty or endorsement thereof.