

# SCRs

查询2N1870供应商

2N1870A-2N1874A, J 24小时加急出货

## 1.25 Amp, Planar

### FEATURES

- Available as Either "JAN" or Standard Types
- Operating D.C. Current Range: 5 to 1250mA
- Pulse Currents: to 30A
- Voltage Ratings: to 200V
- Maximum Trigger Current: 0.2mA
- Maximum Trigger Voltage: 0.8V
- All Leads Isolated from Case
- Maximum  $\theta_{J-C}$ : 20°C/W

### DESCRIPTION

These are premium PNP controlled switches intended for use in applications requiring a high degree of reliability assurance. The JAN types are specified under MIL-S-19500/198, and are included in MIL-STD-701 as recommended types for military usage.

This series is useful in a wide variety of applications including: safety, arming and detonating circuits; timing and programming circuits; protective and warning circuits; driving relays; driving indicator lamps, encoding and decoding circuits; replacing relays, thyatrons, and magamps; servo motor control; pulse generation; plus many others.

8

### ABSOLUTE MAXIMUM RATINGS

	2N1870A JAN2N1870A	2N1871A JAN2N1871A	2N1872A JAN2N1872A	2N1873A —	2N1874A JAN2N1874A
Repetitive Peak Off-State Voltage, $V_{DRM}$	30V	60V	100V	150V	200V
Repetitive Peak Reverse Voltage, $V_{RRM}$	30V	60V	100V	150V	200V
D.C. On-State Current, $I_T$					
100°C Ambient			250mA		
100°C Case			1.25A		
Repetitive Peak On-State Current, $I_{TRM}$			up to 30A		
Peak One Cycle Surge (Non-Rep.) On-State Current, $I_{TSM}$			15A		
Peak Gate Current, $I_{GM}$			250mA		
Average Gate Current, $I_{C(AV)}$			25mA		
Reverse Gate Voltage, $V_{GR}$			5V		
Thermal Resistance, Junction to Case, $R\theta_{J-C}$			20°C/W		
Operating and Storage Temperature Range			-65°C to +150°C		

### MECHANICAL SPECIFICATIONS

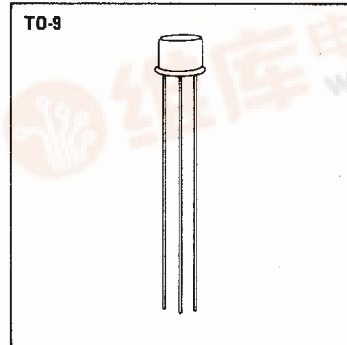
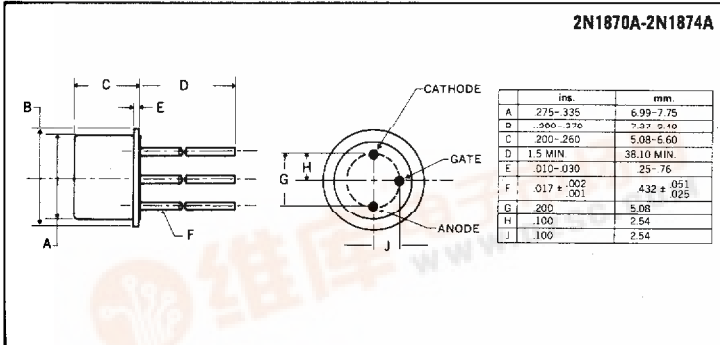

8-5

**Microsemi Corp.**  
Watertown  
The diode experts



**ELECTRICAL SPECIFICATIONS (at 25°C unless noted)†**

Test	Symbol	Min.	Typical	Max.	Units	Test Conditions
<b>Subgroup 1 (Visual and Mechanical)</b>						
<b>Subgroup 2 (25°C Tests)</b>						
Off-State Current	$I_{DRM}$	—	0.5	10	$\mu A$	$R_{GK} = 1K, V_{DRM} = + \text{Rating}$
Reverse Current	$I_{RRM}$	—	0.5	10	$\mu A$	$R_{GK} = 1K, V_{RRM} = - \text{Rating}$
Gate Trigger Voltage	$V_{GT}$	0.4	0.55	0.8	V	$R_{GS} = 100 \text{ ohms}, V_D = 5V$
Gate Trigger Current	$I_{GT}$	—	30	200	$\mu A$	$R_{GS} > 10K \text{ ohms}, V_D = 5V$
On-State Voltage	$V_{TM}$	—	1.8	2.5	V	$I_{TM} = 2A \text{ (pulse test)}$
Off-State Voltage — Critical of Rise	$dV_c/dt$	100	—	—	V/ $\mu S$	Specified test circuit
Reverse Gate Current	$I_{GR}$	—	0.5	10	$\mu A$	$V_{GRM} = 5V, \text{ anode open}$
Holding Current	$I_H$	0.3	—	5.0	mA	$I_G = -150\mu A, V_D = 5V$
<b>Subgroup 3 (125°C Tests)</b>						
High Temp. Off-State Current	$I_{DRM}$	—	15	100	$\mu A$	$R_{GK} = 1K, V_{DRM} = + \text{Rating}$
High Temp. Reverse Current	$I_{RRM}$	—	15	100	$\mu A$	$R_{GK} = 1K, V_{RRM} = - \text{Rating}$
High Temp. Gate Non-Trigger Voltage	$V_{GD}$	0.2	—	—	V	$R_{GS} = 100 \text{ ohms}, V_D = 5V$
High Temp. Holding Current	$I_H$	0.2	—	—	mA	$I_G = -150\mu A, V_D = 5V$
<b>Subgroup 4 (-65°C Tests)</b>						
Low Temp. Gate Trigger Voltage	$V_{GT}$	—	—	1.0	V	$R_{GK} = 100 \text{ ohms}, V_D = 5V$
Low Temp. Gate Trigger Current	$I_{GT}$	—	—	500	$\mu A$	$R_{GK} > 10K \text{ ohms}, V_D = 5V$
Low Temp. Holding Current	$I_H$	—	—	15	mA	$I_G = -150\mu A, V_{AA} = 5V$

†All values in this table are JEDEC registered.

Note: Voltage ratings apply over the full operating temperature range, provided the gate is connected to the cathode through a resistor, 1 K or smaller, or other adequate gate bias is used.

**Triggering and Bias Stabilization**

1. Gate Trigger Current

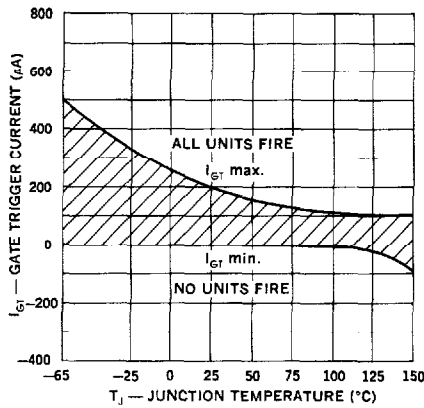

2. Gate Trigger Voltage

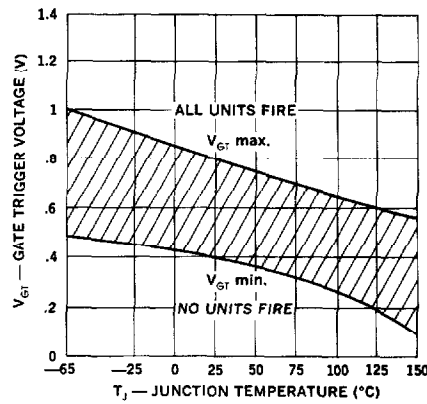

ELECTRICAL SPECIFICATIONS (at 25°C unless noted)†

Test	Symbol	Min.	Typical	Max.	Units	Test Conditions
<b>Subgroup 1 (Visual and Mechanical)</b>						
<b>Subgroup 2 (25°C Tests)</b>						
Off-State Current	$I_{DRM}$	—	0.5	10	$\mu A$	$R_{GK} = 1K, V_{DRM} = + \text{Rating}$
Reverse Current	$I_{RRM}$	—	0.5	10	$\mu A$	$R_{GK} = 1K, V_{RRM} = - \text{Rating}$
Gate Trigger Voltage	$V_{GT}$	0.4	0.55	0.8	V	$R_{GS} = 100 \text{ ohms}, V_D = 5V$
Gate Trigger Current	$I_{GT}$	—	30	200	$\mu A$	$R_{GS} > 10K \text{ ohms}, V_D = 5V$
On-State Voltage	$V_{TM}$	—	1.8	2.5	V	$I_{TM} = 2A \text{ (pulse test)}$
Off-State Voltage — Critical of Rise	$dv_c/dt$	100	—	—	V/ $\mu s$	Specified test circuit
Reverse Gate Current	$I_{CR}$	—	0.5	10	$\mu A$	$V_{GRM} = 5V, \text{ anode open}$
Holding Current	$I_H$	0.3	—	5.0	mA	$I_G = -150\mu A, V_D = 5V$
<b>Subgroup 3 (125°C Tests)</b>						
High Temp. Off-State Current	$I_{DRM}$	—	15	100	$\mu A$	$R_{GK} = 1K, V_{DRM} = + \text{Rating}$
High Temp. Reverse Current	$I_{RRM}$	—	15	100	$\mu A$	$R_{GK} = 1K, V_{RRM} = - \text{Rating}$
High Temp. Gate Non-Trigger Voltage	$V_{GD}$	0.2	—	—	V	$R_{GS} = 100 \text{ ohms}, V_D = 5V$
High Temp. Holding Current	$I_H$	0.2	—	—	mA	$I_G = -150\mu A, V_D = 5V$
<b>Subgroup 4 (-65°C Tests)</b>						
Low Temp. Gate Trigger Voltage	$V_{GT}$	—	—	1.0	V	$R_{GK} = 100 \text{ ohms}, V_D = 5V$
Low Temp. Gate Trigger Current	$I_{GT}$	—	—	500	$\mu A$	$R_{GK} > 10K \text{ ohms}, V_D = 5V$
Low Temp. Holding Current	$I_H$	—	—	15	mA	$I_G = -150\mu A, V_{AA} = 5V$

†All values in this table are JEDEC registered.

Note: Voltage ratings apply over the full operating temperature range, provided the gate is connected to the cathode through a resistor, 1 K or smaller, or other adequate gate bias is used.

Triggering and Bias Stabilization

1. Gate Trigger Current

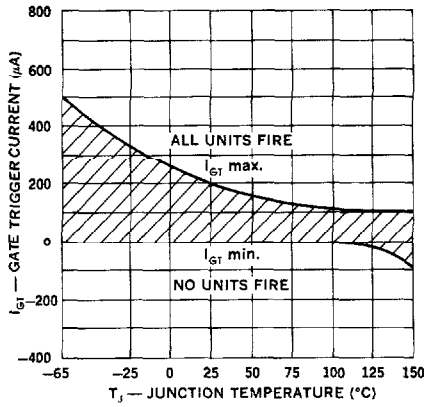

2. Gate Trigger Voltage

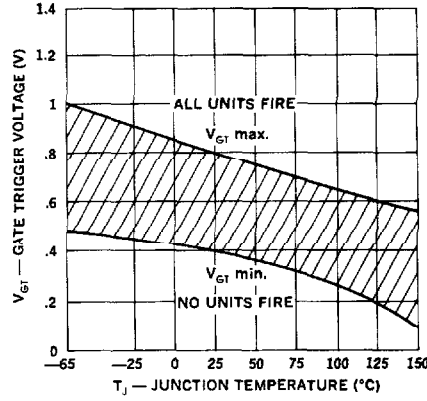

**Holding Current**

**1. Max. Holding Current (Current Bias)**

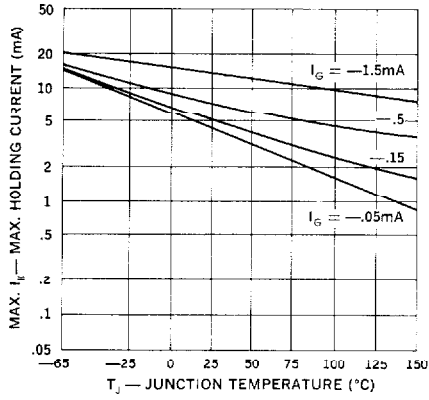

**2. Max. Holding Current (Resistor Bias)**

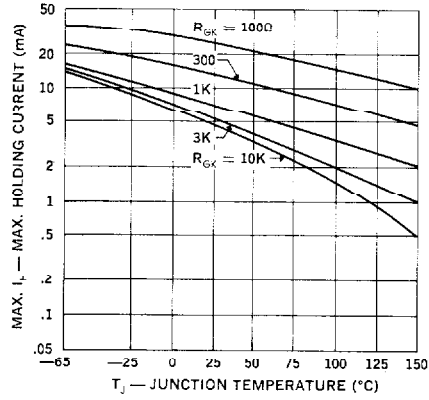

8

**3. Min. Holding Current (Current Bias)**

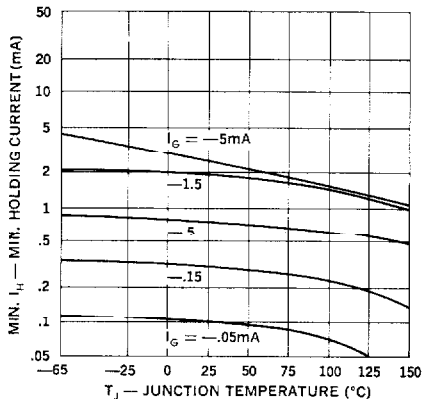

**4. Min. Holding Current (Resistor Bias)**

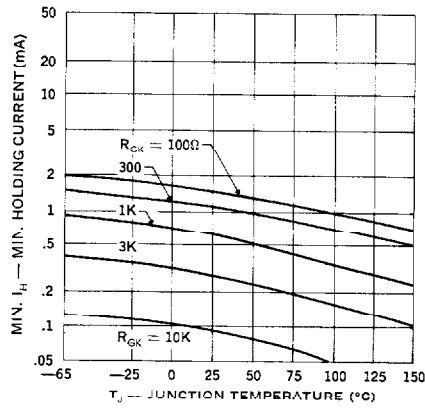

Current Ratings — Thermal Design

1. On-State Current vs. Voltage

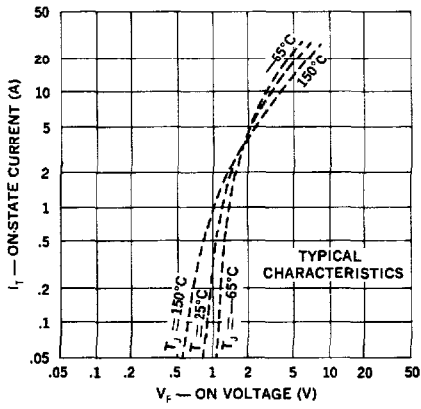

2. Peak Current vs. Case Temperature

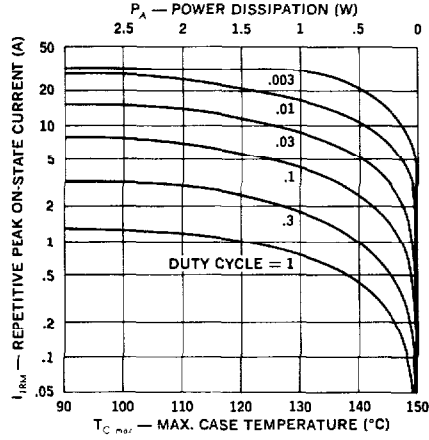

3. Peak Current vs. Ambient Temperature

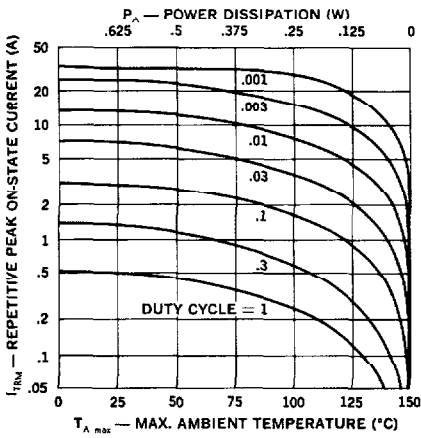

4. Surge Current vs. Time

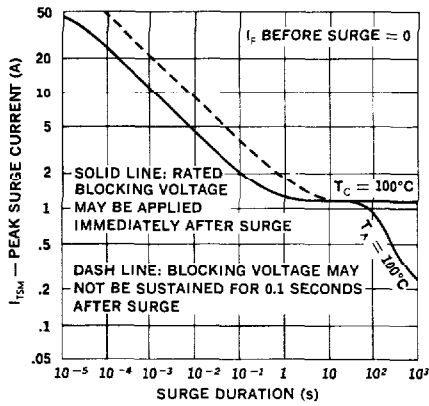

5. Average Current vs. Case Temperature

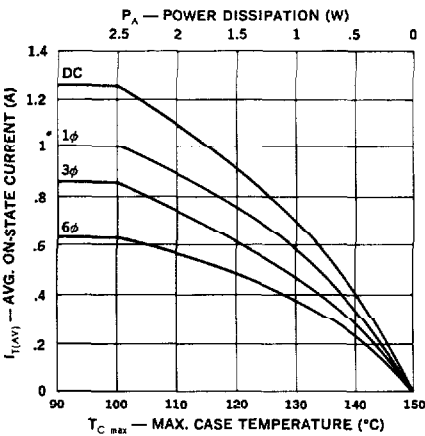

6. Average Current vs. Ambient Temperature

