

Power Transistors



2SB1252

Silicon PNP epitaxial planar type Darlington

For power amplification

Complementary to 2SD1892

Features

- Optimum for 35W HiFi output
- High forward current transfer ratio h_{FE} : 5000 to 30000
- Low collector to emitter saturation voltage $V_{CE(sat)}$: < 2.5V
- Full-pack package which can be installed to the heat sink with one screw

Absolute Maximum Ratings ($T_C=25^\circ C$)

Parameter	Symbol	Ratings	Unit
Collector to base voltage	V_{CBO}	-120	V
Collector to emitter voltage	V_{CEO}	-100	V
Emitter to base voltage	V_{EBO}	-5	V
Peak collector current	I_{CP}	-8	A
Collector current	I_C	-5	A
Collector power dissipation	P_C	$T_C=25^\circ C$	45
		$T_a=25^\circ C$	2
Junction temperature	T_j	150	$^\circ C$
Storage temperature	T_{stg}	-55 to +150	$^\circ C$

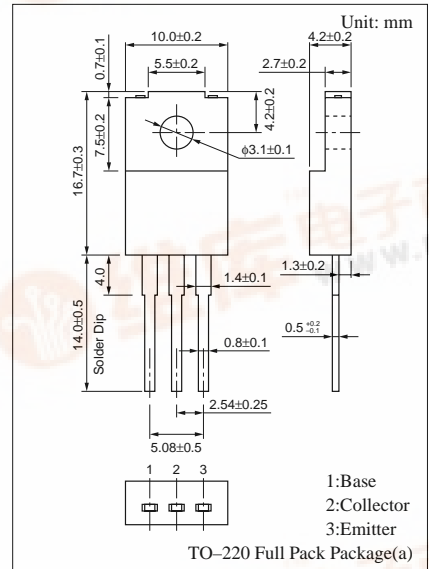

Internal Connection

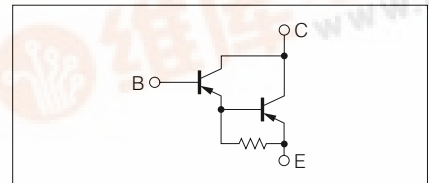

Electrical Characteristics ($T_C=25^\circ C$)

Parameter	Symbol	Conditions	min	typ	max	Unit
Collector cutoff current	I_{CBO}	$V_{CB} = -120V, I_E = 0$			-100	μA
	I_{CEO}	$V_{CE} = -100V, I_B = 0$			-100	μA
Emitter cutoff current	I_{EBO}	$V_{EB} = -5V, I_C = 0$			-100	μA
Collector to emitter voltage	V_{CEO}	$I_C = -30mA, I_B = 0$	-100			V
	h_{FE1}	$V_{CE} = -5V, I_C = -1A$	2000			
Forward current transfer ratio	h_{FE2}^*	$V_{CE} = -5V, I_C = -4A$	5000		30000	
	$V_{CE(sat)}$	$I_C = -4A, I_B = -4mA$			-2.5	V
Base to emitter saturation voltage	$V_{BE(sat)}$	$I_C = -4A, I_B = -4mA$			-3.0	V
Transition frequency	f_T	$V_{CE} = -10V, I_C = -0.5A, f = 1MHz$		20		MHz
Turn-on time	t_{on}	$I_C = -4A, I_{B1} = -4mA, I_{B2} = 4mA, V_{CC} = -50V$		1.0		μs
Storage time	t_{stg}			0.8		μs
Fall time	t_f			1.0		μs

h_{FE2} Rank classification

Rank	Q	P
h_{FE2}	5000 to 15000	8000 to 30000



$P_C - T_a$

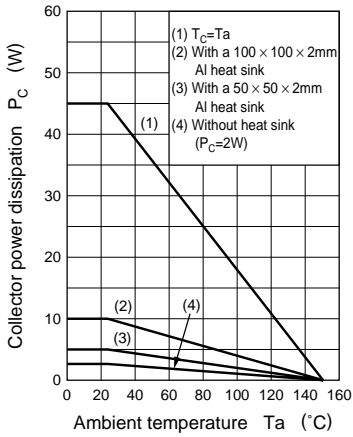

$I_C - V_{CE}$

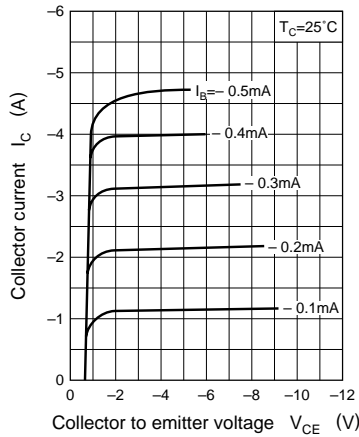

$V_{CE(sat)} - I_C$

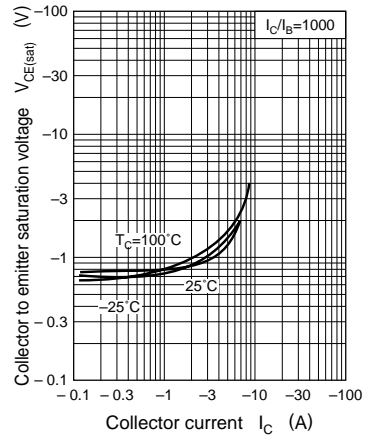

$V_{BE(sat)} - I_C$

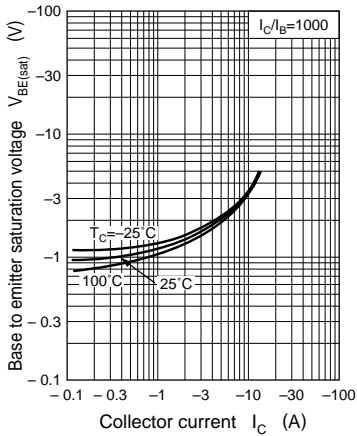

$h_{FE} - I_C$

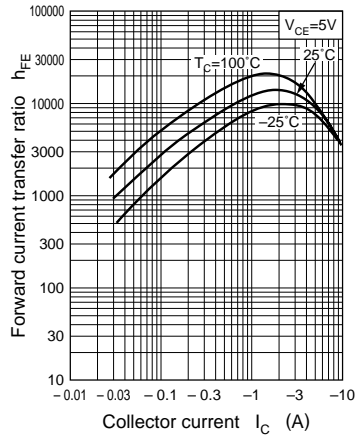

$C_{ob} - V_{CB}$

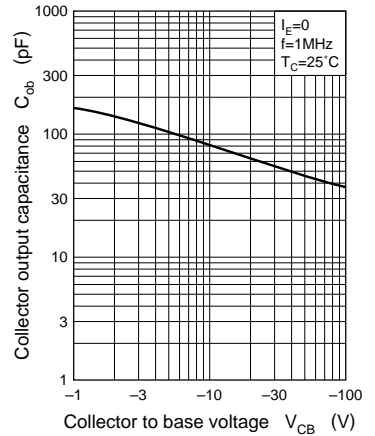

$t_{on}, t_{stg}, t_f - I_C$

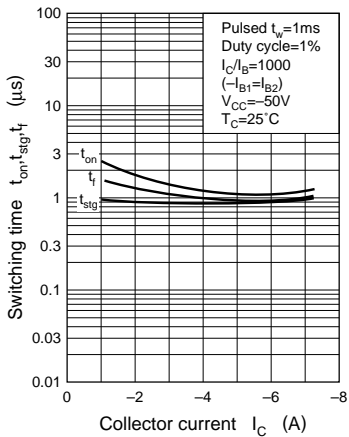

Area of safe operation (ASO)

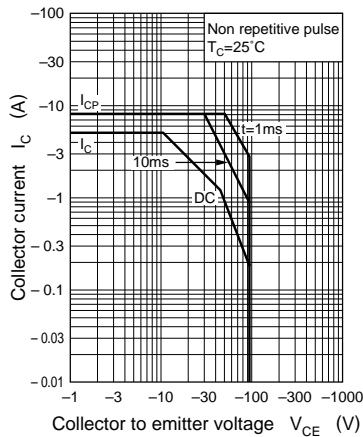

$$R_{th(t)} - t$$

