

2SC1317, 2SC1318

Silicon NPN epitaxial planer type

For low-frequency power amplification and driver amplification
Complementary to 2SA719 and 2SA720

■ Features

- Low collector to emitter saturation voltage $V_{CE(sat)}$
- Complementary pair with 2SA719 and 2SA720

■ Absolute Maximum Ratings $T_a = 25^\circ\text{C}$

Parameter	Symbol	Rating	Unit
Collector to base voltage	2SC1317	30	V
	2SC1318	60	
Collector to emitter voltage	2SC1317	25	V
	2SC1318	50	
Emitter to base voltage	V_{EBO}	7	V
Peak collector current	I_{CP}	1	A
Collector current	I_C	500	mA
Collector power dissipation	P_C	625	mW
Junction temperature	T_j	150	$^\circ\text{C}$
Storage temperature	T_{stg}	-55 to +150	$^\circ\text{C}$

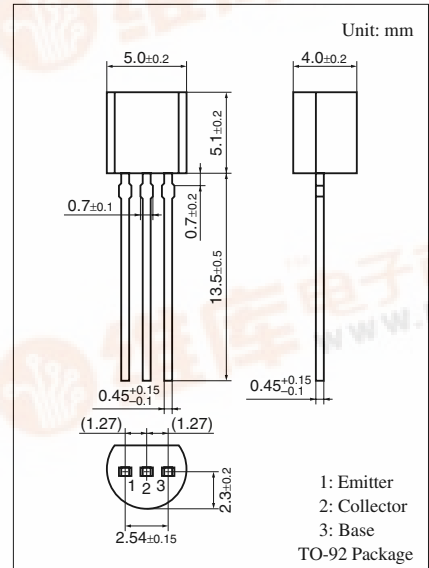

■ Electrical Characteristics $T_a = 25^\circ\text{C} \pm 3^\circ\text{C}$

Parameter	Symbol	Conditions	Min	Typ	Max	Unit
Collector cutoff current	I_{CBO}	$V_{CB} = 20\text{ V}, I_E = 0$			0.1	μA
Collector to base voltage	2SC1317	$I_C = 10\ \mu\text{A}, I_E = 0$	30			V
	2SC1318		60			
Collector to emitter voltage	2SC1317	$I_C = 10\ \text{mA}, I_B = 0$	25			V
	2SC1318		50			
Emitter to base voltage	V_{EBO}	$I_E = 10\ \mu\text{A}, I_C = 0$	7			V
Forward current transfer ratio *1	h_{FE1} *2	$V_{CE} = 10\ \text{V}, I_C = 150\ \text{mA}$	85		340	
	h_{FE2}	$V_{CE} = 10\ \text{V}, I_C = 500\ \text{mA}$	40			
Collector to emitter saturation voltage *1	$V_{CE(sat)}$	$I_C = 300\ \text{mA}, I_B = 30\ \text{mA}$		0.35	0.6	V
Base to emitter saturation voltage *1	$V_{BE(sat)}$	$I_C = 300\ \text{mA}, I_B = 30\ \text{mA}$		1.1	1.5	V
Transition frequency	f_T	$V_{CB} = 10\ \text{V}, I_E = -50\ \text{mA}, f = 200\ \text{MHz}$		200		MHz
Collector output capacitance	C_{ob}	$V_{CB} = 10\ \text{V}, I_E = 0, f = 1\ \text{MHz}$		6	15	pF

Note) *1: Pulse measurement

*2: Rank classification

Rank	Q	R	S
h_{FE1}	85 to 170	120 to 240	170 to 340



