

TOSHIBA FIELD EFFECT TRANSISTOR SILICON N CHANNEL JUNCTION TYPE

2SK118

GENERAL PURPOSE AND IMPEDANCE CONVERTER AND CONDENSER MICROPHONE APPLICATIONS

Unit in mm

- High Breakdown Voltage : $V_{GDS} = -50V$
- High Input Impedance : $I_{GSS} = -1nA$ (Max.) ($V_{GS} = -30V$)
- Low Noise : $NF = 0.5dB$ (Typ.)
($R_G = 100k\Omega$, $f = 120Hz$)
- Small Package

MAXIMUM RATINGS ($T_a = 25^\circ C$)

CHARACTERISTIC	SYMBOL	RATING	UNIT
Gate-Drain Voltage	V_{GDS}	-50	V
Gate Current	I_G	10	mA
Drain Power Dissipation	P_D	100	mW
Junction Temperature	T_j	125	$^\circ C$
Storage Temperature Range	T_{stg}	-55~125	$^\circ C$

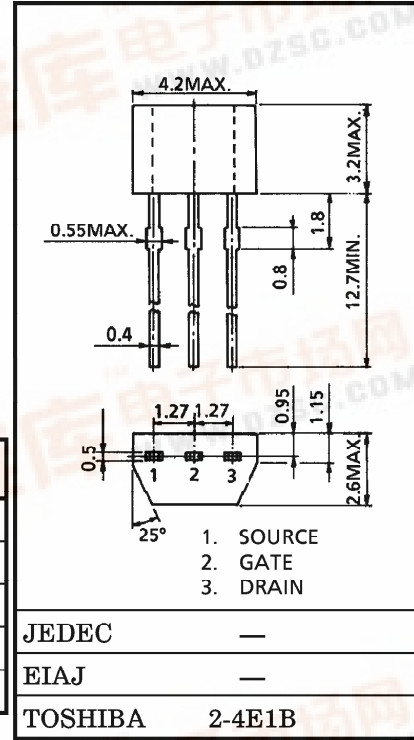

Weight : 0.13g (Typ.)

ELECTRICAL CHARACTERISTICS ($T_a = 25^\circ C$)

CHARACTERISTIC	SYMBOL	TEST CONDITION	MIN.	TYP.	MAX.	UNIT
Gate Cut-off Current	I_{GSS}	$V_{GS} = -30V$, $V_{DS} = 0$	—	—	-1.0	nA
Gate-Drain Breakdown Voltage	$V_{(BR)GDS}$	$V_{DS} = 0$, $I_G = -100\mu A$	-50	—	—	V
Drain Current	I_{DSS} (Note)	$V_{DS} = 10V$, $V_{GS} = 0$	0.3	—	6.5	mA
Gate-Source Cut-off Voltage	$V_{GS(OFF)}$	$V_{DS} = 10V$, $I_D = 0.1\mu A$	-0.4	—	-5.0	V
Forward Transfer Admittance	$ Y_{fs} $	$V_{DS} = 10V$, $V_{GS} = 0$, $f = 1kHz$	1.2	—	—	mS
Input Capacitance	C_{iss}	$V_{DS} = 10V$, $V_{GS} = 0$, $f = 1MHz$	—	8.2	—	pF
Reverse Transfer Capacitance	C_{rss}	$V_{GD} = -10V$, $I_D = 0$, $f = 1MHz$	—	2.6	—	pF
Noise Figure	NF	$V_{DS} = 15V$, $V_{GS} = 0$, $R_G = 100k\Omega$, $f = 120Hz$	—	0.5	5.0	dB

Note : I_{DSS} Classification R : 0.3~0.75mA, O : 0.6~1.4mA, Y : 1.2~3.0mA,
GR : 2.6~6.5mA

961001FAA2

TOSHIBA is continually working to improve the quality and the reliability of its products. Nevertheless, semiconductor devices in general can malfunction or fail due to their inherent electrical sensitivity and vulnerability to physical stress. It is the responsibility of the buyer, when utilizing TOSHIBA products, to observe standards of safety, and to avoid situations in which a malfunction or failure of a TOSHIBA product could cause loss of human life, bodily injury or damage to property. In developing your designs, please ensure that TOSHIBA products are used within specified operating ranges as set forth in the most recent products specifications. Also, please keep in mind the precautions and conditions set forth in the TOSHIBA Semiconductor Reliability Handbook.



