



2W005M THRU 2W10M

Single Phase 2.0 AMPS. Silicon Bridge Rectifiers

Features

- UL Recognized
- Surge overload ratings to 30 amperes peak
- Ideal for printed circuit board
- Reliable low cost construction technique results in inexpensive product
- High temperature soldering guaranteed: 250°C / 10 seconds / 0.375" (9.5mm) lead length at 5 lbs., (2.3 kg) tension

Mechanical Data

- Case: Molded plastic
- Lead: Solder plated
- Polarity: As marked
- Weight: 1.10 grams

Voltage Range
50 to 1000 Volts
Current
2.0 Amperes

WOB

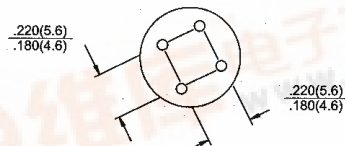
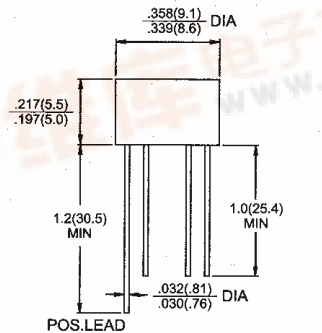

Dimensions in inches and (millimeters)

Maximum Ratings and Electrical Characteristics

Rating at 25°C ambient temperature unless otherwise specified.

Single phase, half wave, 60 Hz, resistive or inductive load.

For capacitive load, derate current by 20%

Symbol	2W005M	2W01M	2W02M	2W04M	2W06M	2W08M	2W10M	Units
Maximum Recurrent Peak Reverse Voltage	50	100	200	400	600	800	1000	V
Maximum RMS Voltage	35	70	140	280	420	560	700	V
Maximum DC Blocking Voltage	50	100	200	400	600	800	1000	V
Maximum Average Forward Rectified Current @ T _A = 50°C	2.0							A
Peak Forward Surge Current, 8.3 ms Single Half Sine-wave Superimposed on Rated Load (JEDEC method)	50							A
Maximum Instantaneous Forward Voltage @ 2.0A	1.1							V
Maximum DC Reverse Current @ T _A =25°C at Rated DC Blocking Voltage @ T _A =100°C	10 500							uA uA
Operating Temperature Range T _J	-55 to +125							°C
Storage Temperature Range T _{STG}	-55 to +150							°C

RATINGS AND CHARACTERISTIC CURVES (2W005M THRU 2W10M)

FIG.1- MAXIMUM NON-REPETITIVE FORWARD SURGE CURRENT PER BRIDGE ELEMENT

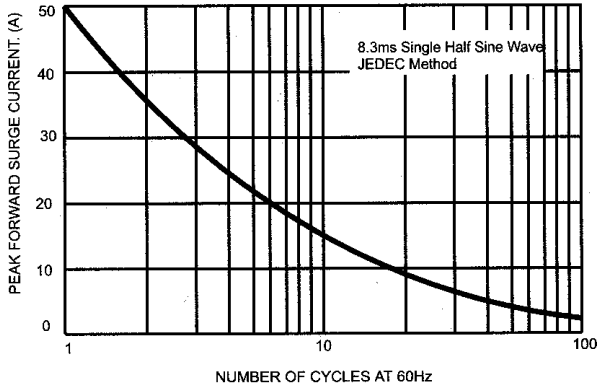

FIG.2- MAXIMUM CURRENT DERATING CURVE OUTPUT RECTIFIED CURRENT

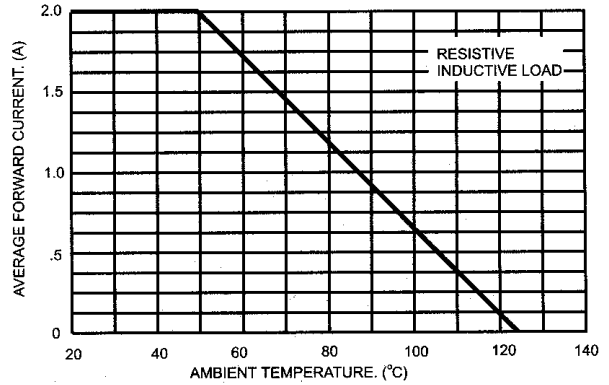

FIG.3- TYPICAL INSTANTANEOUS FORWARD CHARACTERISTICS PER BRIDGE ELEMENT

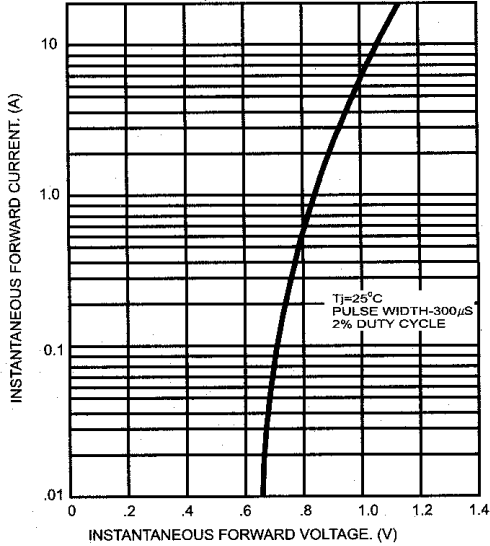

FIG.4- TYPICAL REVERSE CHARACTERISTICS PER BRIDGE ELEMENT

