

Bulletin PD-20768 rev. C 09/04

International IR Rectifier

30CTH02
30CTH02S
30CTH02-1
30CTH02FP

Hyperfast Rectifier

Features

- Hyperfast Recovery Time
- Low Forward Voltage Drop
- Low Leakage Current
- 175°C Operating Junction Temperature

$t_{rr} = 30\text{ns max.}$
 $I_{F(AV)} = 30\text{Amp}$
 $V_R = 200\text{V}$

Description/ Applications

International Rectifier's 200V series are the state of the art Hyperfast recovery rectifiers specifically designed with optimized performance of forward voltage drop and hyperfast recovery time.

The planar structure and the platinum doped life time control, guarantee the best overall performance, ruggedness and reliability characteristics.





These devices are intended for use in the output rectification stage of SMPS, UPS, DC-DC converters as well as free-wheeling diode in low voltage inverters and chopper motor drives.

Their extremely optimized stored charge and low recovery current minimize the switching losses and reduce over dissipation in the switching element and snubbers.

Absolute Maximum Ratings

Parameters	Max	Units
V_{RRM} Peak Repetitive Reverse Voltage	200	V
$I_{F(AV)}$ Average Rectified Forward Current @ $T_C = 159^\circ\text{C}$ Per Diode	15	A
@ $T_C = 125^\circ\text{C}$ (FULLPACK) Per Diode	30	
Per Device	30	
I_{FSM} Non Repetitive Peak Surge Current @ $T_J = 25^\circ\text{C}$	200	
T_J, T_{STG} Operating Junction and Storage Temperatures	- 65 to 175	$^\circ\text{C}$

Case Styles

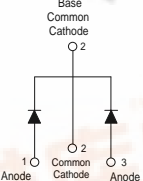
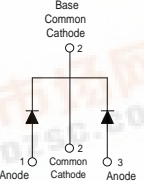
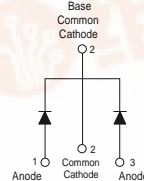
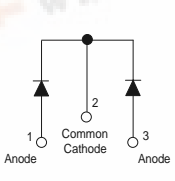
30CTH02	30CTH02S	30CTH02-1	30CTH02FP
			
<p>Base Common Cathode 2</p>  <p>1 Anode 2 Common 3 Anode</p> <p>TO-220AB</p>	<p>Base Common Cathode 2</p>  <p>1 Anode 2 Common 3 Anode</p> <p>D²PAK</p>	<p>Base Common Cathode 2</p>  <p>1 Anode 2 Common 3 Anode</p> <p>TO-262</p>	 <p>1 Anode 2 Common 3 Anode</p> <p>TO-220 FULLPACK</p>

Electrical Characteristics @ $T_J = 25^\circ\text{C}$ (unless otherwise specified)

Parameters	Min	Typ	Max	Units	Test Conditions
V_{BR}, V_r Breakdown Voltage, Blocking Voltage	200	-	-	V	$I_R = 100\mu\text{A}$
V_F Forward Voltage	-	0.92	1.05	V	$I_F = 15\text{A}, T_J = 25^\circ\text{C}$
	-	0.78	0.85	V	$I_F = 15\text{A}, T_J = 125^\circ\text{C}$
I_R Reverse Leakage Current	-	-	10	μA	$V_R = V_R$ Rated
	-	5	300	μA	$T_J = 125^\circ\text{C}, V_R = V_R$ Rated
C_T Junction Capacitance	-	57	-	pF	$V_R = 200\text{V}$
L_S Series Inductance	-	8	-	nH	Measured lead to lead 5mm from package body

Dynamic Recovery Characteristics @ $T_C = 25^\circ\text{C}$ (unless otherwise specified)

Parameters	Min	Typ	Max	Units	Test Conditions
t_{rr} Reverse Recovery Time	-	-	35	ns	$I_F = 1\text{A}, di_F/dt = 50\text{A}/\mu\text{s}, V_R = 30\text{V}$
	-	-	30		$I_F = 1\text{A}, di_F/dt = 100\text{A}/\mu\text{s}, V_R = 30\text{V}$
	-	26	-	A	$T_J = 25^\circ\text{C}$
	-	40	-		$T_J = 125^\circ\text{C}$
I_{RRM} Peak Recovery Current	-	2.8	-	A	$T_J = 25^\circ\text{C}$
	-	6.0	-		$T_J = 125^\circ\text{C}$
Q_{rr} Reverse Recovery Charge	-	37	-	nC	$T_J = 25^\circ\text{C}$
	-	120	-		$T_J = 125^\circ\text{C}$

Thermal - Mechanical Characteristics

Parameters	Min	Typ	Max	Units
T_J Max. Junction Temperature Range	-	-	175	$^\circ\text{C}$
T_{Stg} Max. Storage Temperature Range	- 65	-	175	
R_{thJC} ① Thermal Resistance, Per Diode	-	-	1.1	$^\circ\text{C}/\text{W}$
	Junction to Case Fullpack (Per Diode)	-	-	
Device Marking	30CTH02			Case Style TO-220
	30CTH02S			Case Style D ² Pak
	30CTH02-1			Case Style TO-262
	30CTH02FP			Case Style Fullpack

① Mounting Surface, Flat, Smooth and Greased

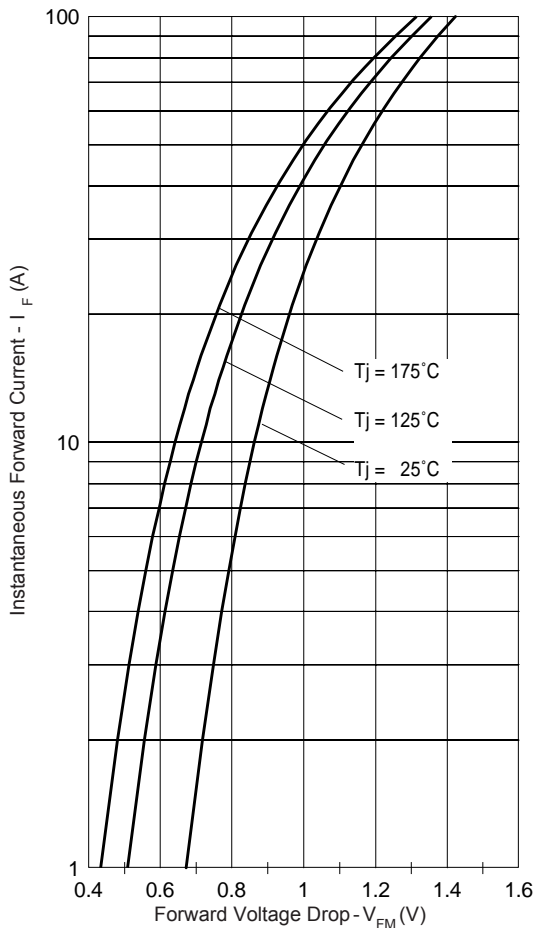

Fig. 1 - Typical Forward Voltage Drop Characteristics

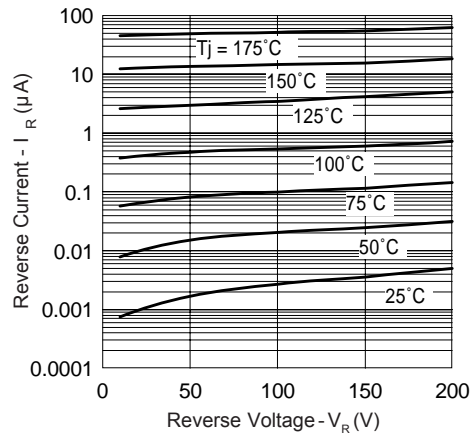

Fig. 2 - Typical Values of Reverse Current Vs. Reverse Voltage

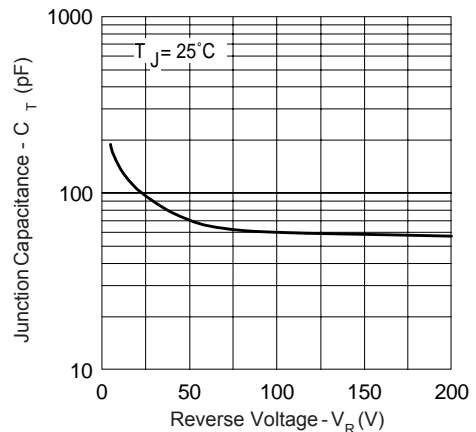

Fig. 3 - Typical Junction Capacitance Vs. Reverse Voltage

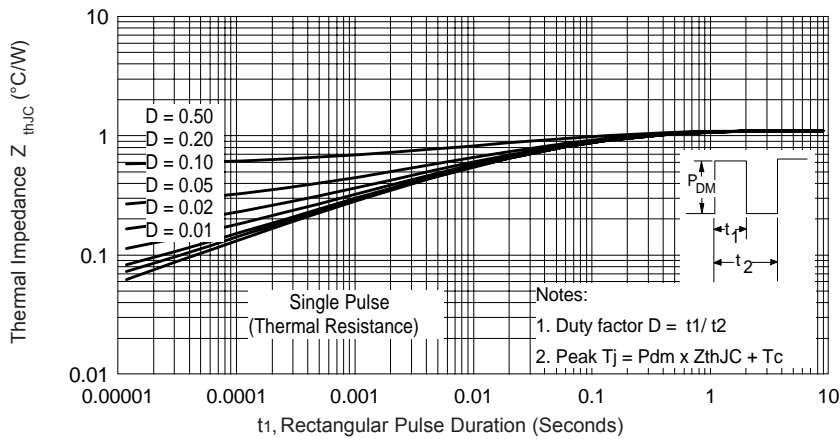

Fig. 4 - Max. Thermal Impedance Z_{thJC} Characteristics

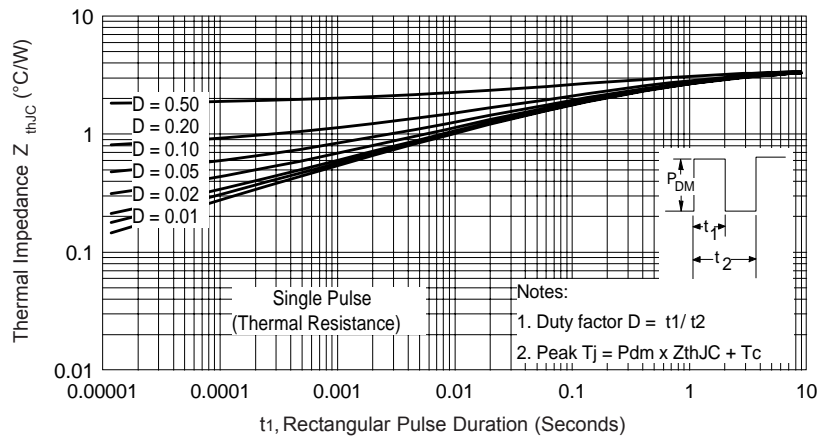

Fig. 5 - Max. Thermal Impedance Z_{thJC} Characteristics (FULLPACK)

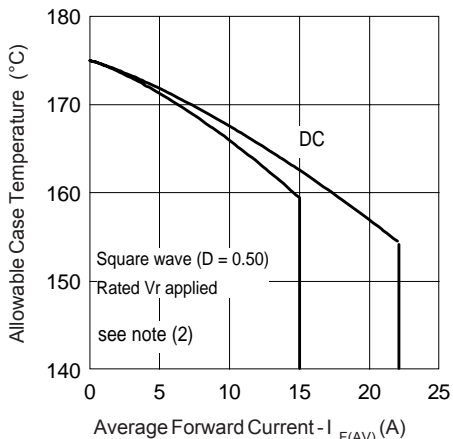

Fig. 6 - Max. Allowable Case Temperature Vs. Average Forward Current

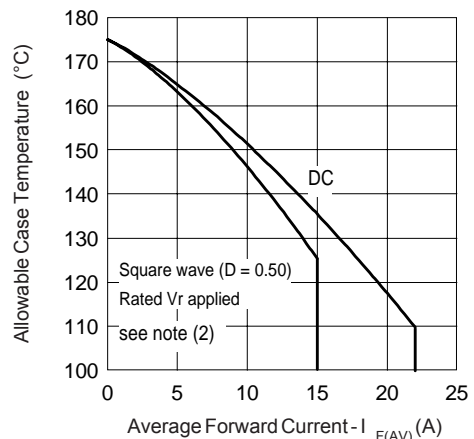

Fig. 7 - Max. Allowable Case Temperature Vs. Average Forward Current (FULLPACK)

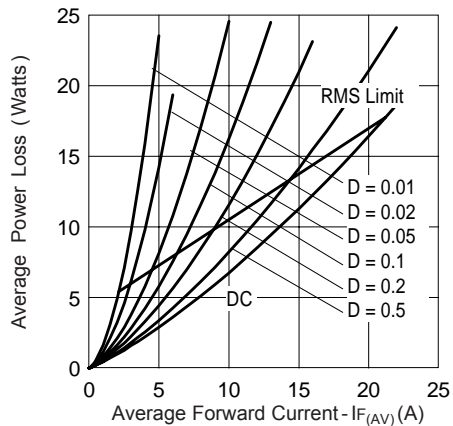

Fig. 8 - Forward Power Loss Characteristics

(2) Formula used: $T_c = T_J - (P_d + P_{d_{REV}}) \times R_{thJC}$;
 $P_d = \text{Forward Power Loss} = I_{F(AV)} \times V_{FM} @ (I_{F(AV)}/D)$
 (see Fig. 8);
 $P_{d_{REV}} = \text{Inverse Power Loss} = V_{R1} \times I_R (1-D)$;
 $I_R @ V_{R1} = \text{rated } V_R$

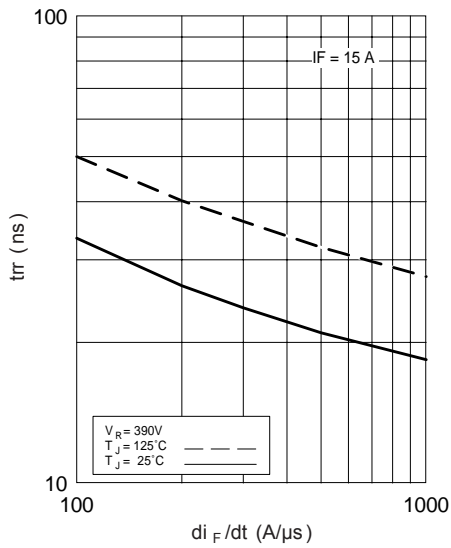

Fig. 9 - Typical Reverse Recovery vs. di_F/dt

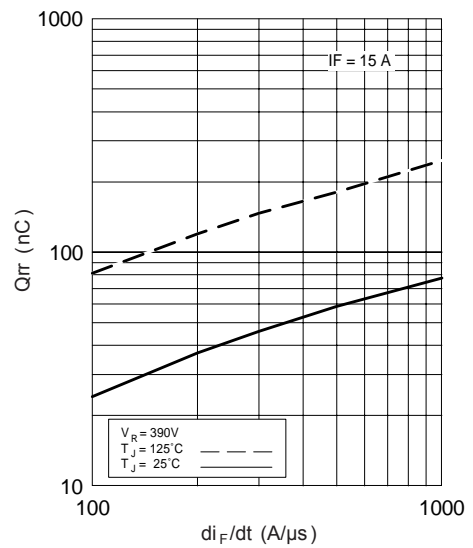

Fig. 10 - Typical Stored Charge vs. di_F/dt

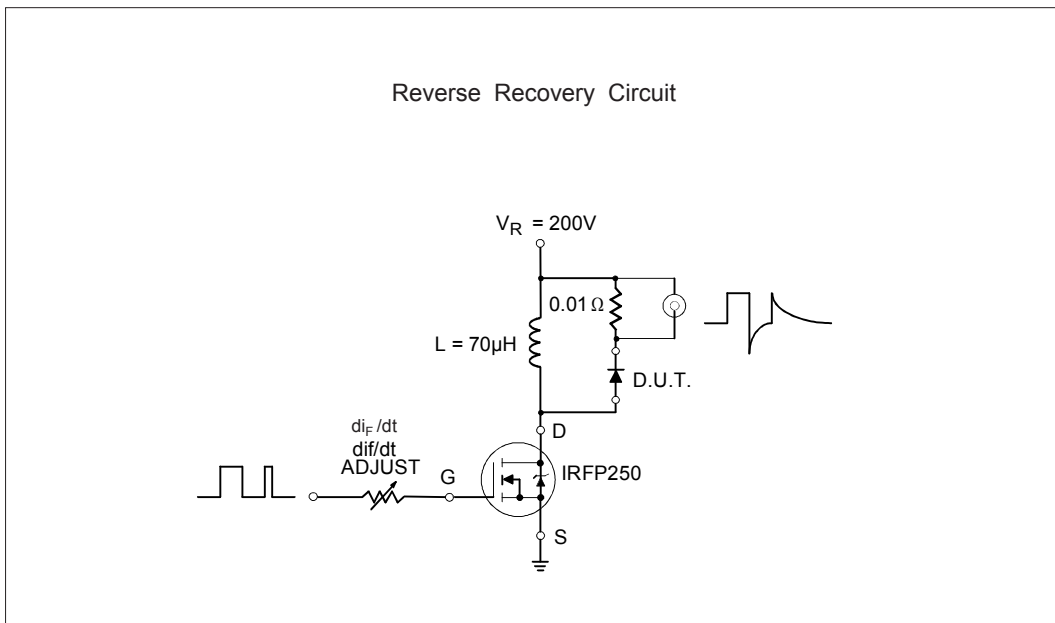

Fig. 11 - Reverse Recovery Parameter Test Circuit

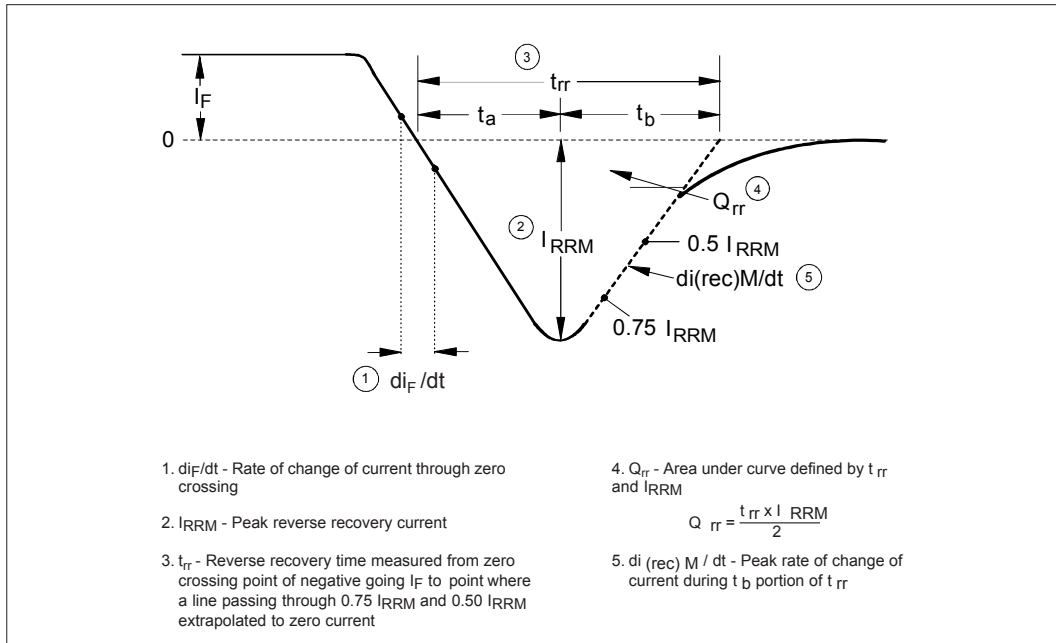
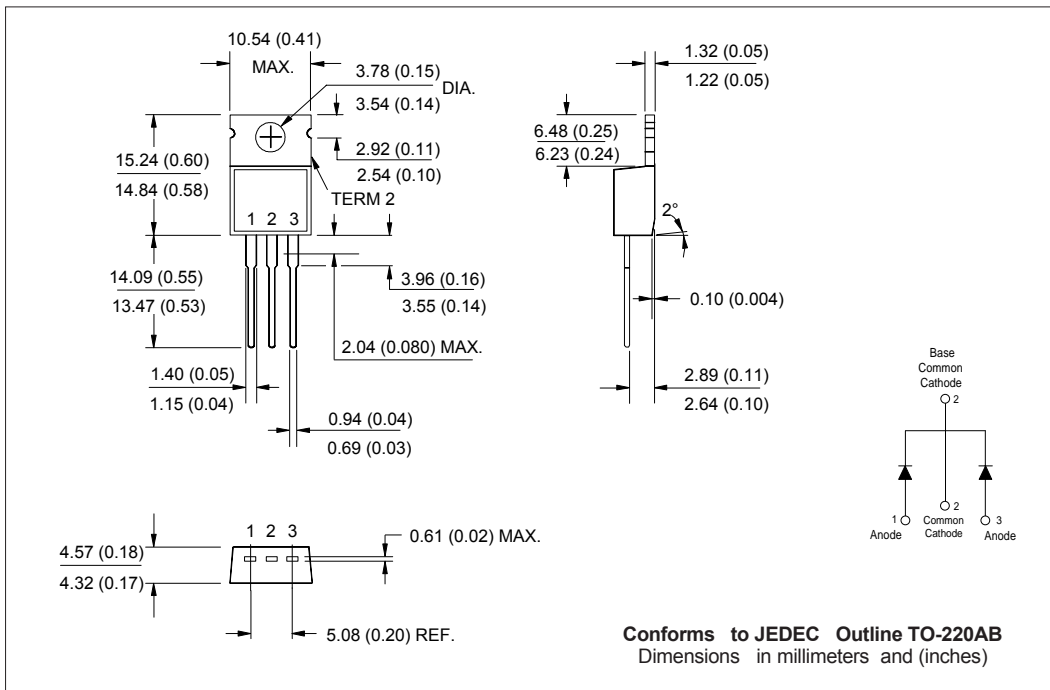
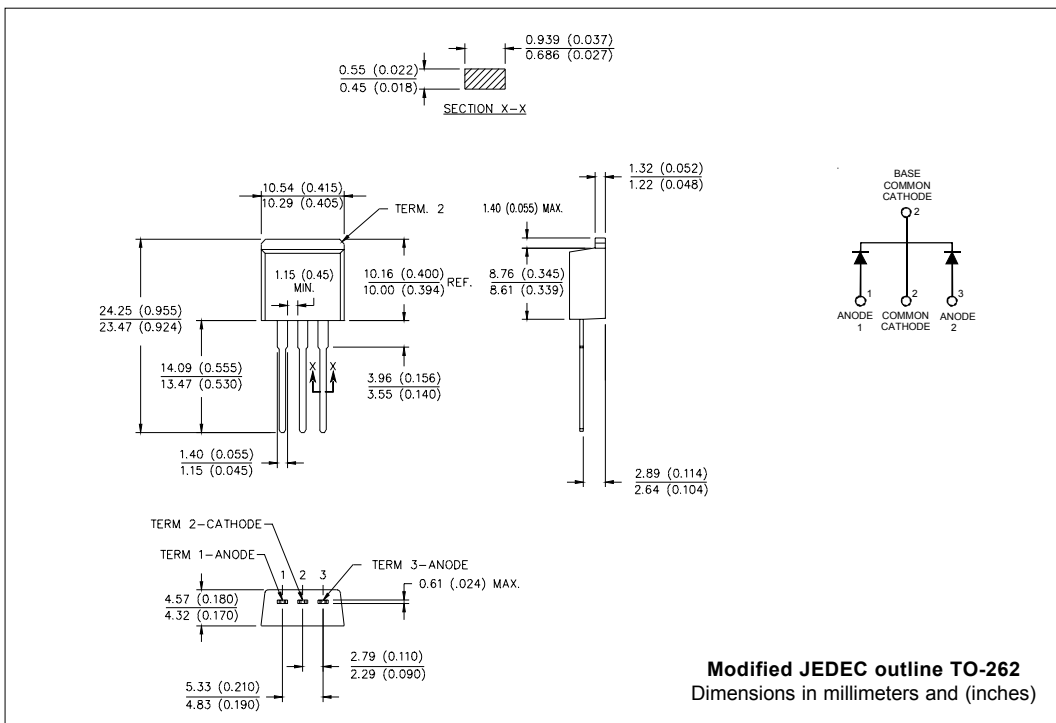
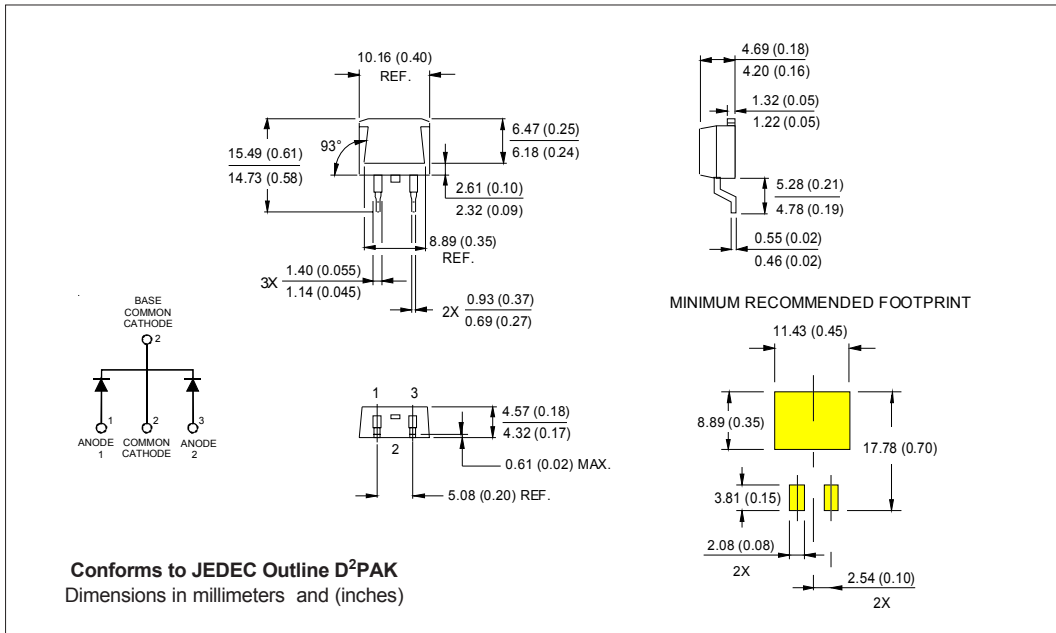

Fig. 13 - Reverse Recovery Waveform and Definitions

Outline Table



Outline Table



Outline Table

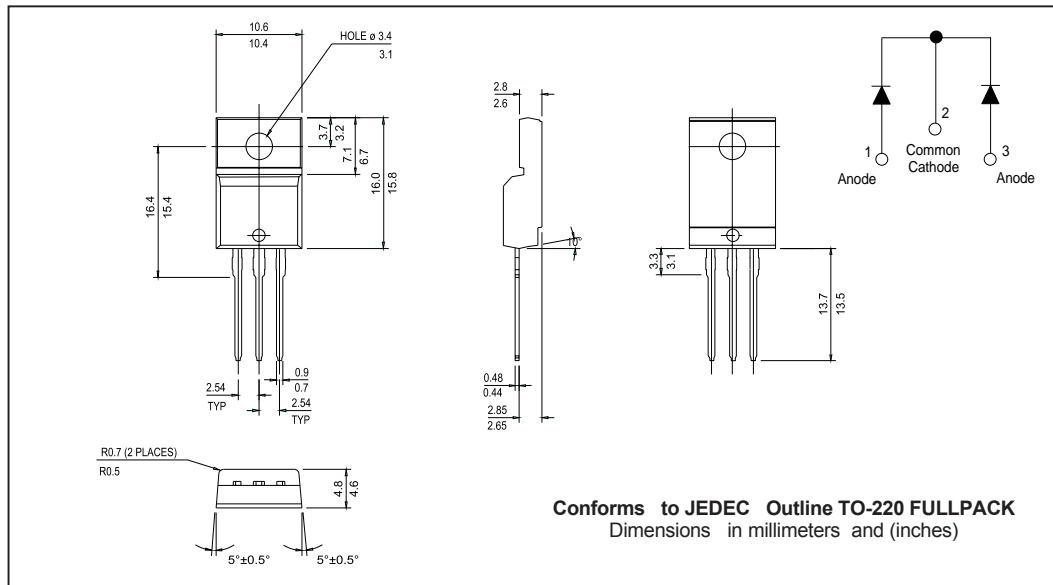

Tape & Reel Information

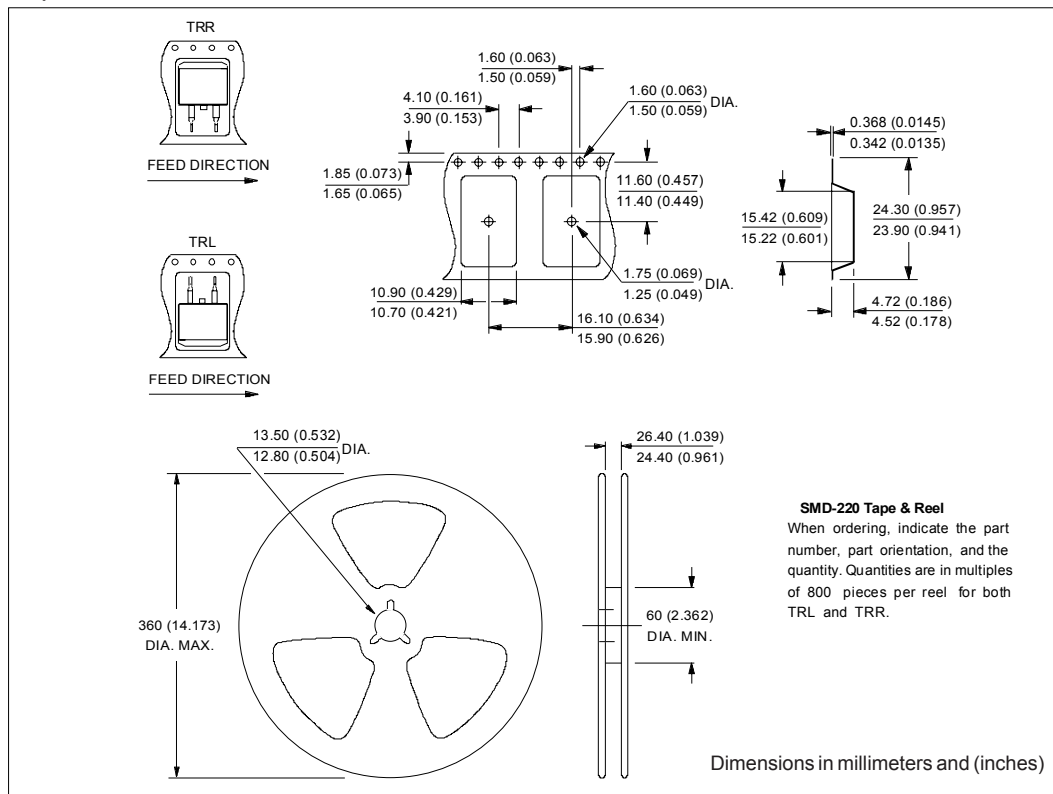

Part Marking Information

<p>EXAMPLE: THIS IS A 32CTH02 LOT CODE 1789 ASSEMBLED ON WW 19, 2000 IN THE ASSEMBLY LINE "C"</p>	<p>INTERNATIONAL RECTIFIER LOGO</p> <p>ASSEMBLY LOT CODE</p> <p>PART NUMBER</p> <p>DATE CODE YEAR 0 = 2000 WEEK 19 LINE C</p>
<p>TO-220AB</p>	
<p>EXAMPLE: THIS IS A 32CTH02S LOT CODE 8024 ASSEMBLED ON WW 02, 2000 IN THE ASSEMBLY LINE "L"</p>	<p>INTERNATIONAL RECTIFIER LOGO</p> <p>ASSEMBLY LOT CODE</p> <p>PART NUMBER</p> <p>DATE CODE YEAR 0 = 2000 WEEK 02 LINE L</p>
<p>D²PAK</p>	
<p>EXAMPLE: THIS IS A 32CTH02-1 LOT CODE 1789 ASSEMBLED ON WW 19, 1999 IN THE ASSEMBLY LINE "C"</p>	<p>INTERNATIONAL RECTIFIER LOGO</p> <p>ASSEMBLY LOT CODE</p> <p>PART NUMBER</p> <p>DATE CODE YEAR 9 = 1999 WEEK 19 LINE C</p>
<p>TO-262</p>	
<p>EXAMPLE: THIS IS A 32CTH02FP LOT CODE 1789 ASSEMBLED ON WW 19, 2000 IN THE ASSEMBLY LINE "C"</p>	<p>INTERNATIONAL RECTIFIER LOGO</p> <p>ASSEMBLY LOT CODE</p> <p>PART NUMBER</p> <p>DATE CODE YEAR 0 = 2000 WEEK 19 LINE C</p>
<p>FULLPACK</p>	

Ordering Information Table

Device Code	30	C	T	H	02	-1	TRL
	①	②	③	④	⑤	⑥	⑦
1	-	Current Rating (30 = 30A)					
2	-	C = Common Cathode					
3	-	T = TO-220					
4	-	H = HyperFast Recovery					
5	-	Voltage Rating (02 = 200V)					
6	-	None = TO-220AB					
		S = D ² Pak					
		-1 = TO-262 Option					
		FP = TO-220 FULLPACK					
7		None = Tube (50 pieces)					
		TRL = Tape & Reel (Left Oriented - for D ² Pak only)					
		TRR = Tape & Reel (Right Oriented - for D ² Pak only)					

Data and specifications subject to change without notice.
This product has been designed and qualified for Industrial Level.
Qualification Standards can be found on IR's Web site.