

# 3185 THRU 3189

## HALL-EFFECT LATCHES FOR HIGH-TEMPERATURE OPERATION

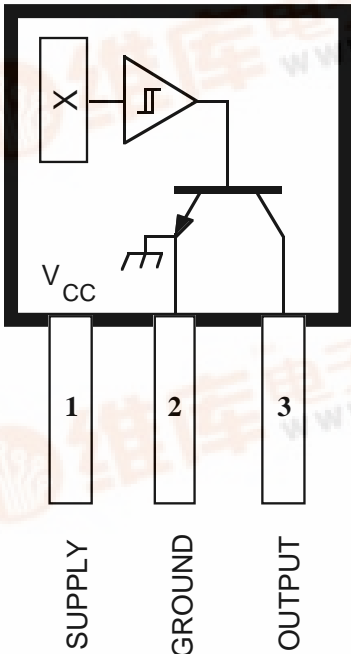

Dwg. PH-003A

Pinning is shown viewed from branded side.

### ABSOLUTE MAXIMUM RATINGS at $T_A = +25^\circ\text{C}$

Supply Voltage, $V_{CC}$ .....	30 V
Reverse Battery Voltage, $V_{RCC}$ .....	-30 V
Magnetic Flux Density, B .....	Unlimited
Output OFF Voltage, $V_{OUT}$ .....	30 V
Reverse Output Voltage, $V_{OUT}$ .....	-0.5 V
Continuous Output Current, $I_{OUT}$ .....	25 mA
Operating Temperature Range, $T_A$	
Suffix 'E-' .....	-40°C to +85°C
Suffix 'L-' .....	-40°C to +150°C
Storage Temperature Range,	
$T_S$ .....	-65°C to +170°C

These Hall-effect latches are extremely temperature-stable and stress-resistant sensors especially suited for operation over extended temperature ranges to +150°C. Superior high-temperature performance is made possible through a novel Schmitt trigger circuit that maintains operate and release point symmetry by compensating for temperature changes in the Hall element. Additionally, internal compensation provides magnetic switch points that become more sensitive with temperature, hence offsetting the usual degradation of the magnetic field with temperature. The symmetry capability makes these devices ideal for use in pulse-counting applications where duty cycle is an important parameter. The four basic devices (3185, 3187, 3188, and 3189) are identical except for magnetic switch points.

Each device includes on a single silicon chip a voltage regulator, quadratic Hall-voltage generator, temperature compensation circuit, signal amplifier, Schmitt trigger, and a buffered open-collector output to sink up to 25 mA. The on-board regulator permits operation with supply voltages of 3.8 to 24 volts.

The first character of the part number suffix determines the device operating temperature range. Suffix 'E-' is for -40°C to +85°C, and suffix 'L-' is for -40°C to +150°C. Three package styles provide a magnetically optimized package for most applications. Suffix '-LT' is a miniature SOT89/TO-243AA transistor package for surface-mount applications; suffix '-UA' is a three-lead ultra-mini-SIP.

### FEATURES

- Symmetrical Switch Points
- Superior Temperature Stability
- Operation From Unregulated Supply
- Open-Collector 25 mA Output
- Reverse Battery Protection
- Activate With Small, Commercially Available Permanent Magnets
- Solid-State Reliability
- Small Size
- Resistant to Physical Stress

Always order by complete part number: the prefix 'A' + the basic four-digit part number + a suffix to indicate operating temperature range + a suffix to indicate package style, e.g., **A3185ELT**.



# 3185 THRU 3189 HALL-EFFECT LATCHES FOR HIGH-TEMPERATURE OPERATION

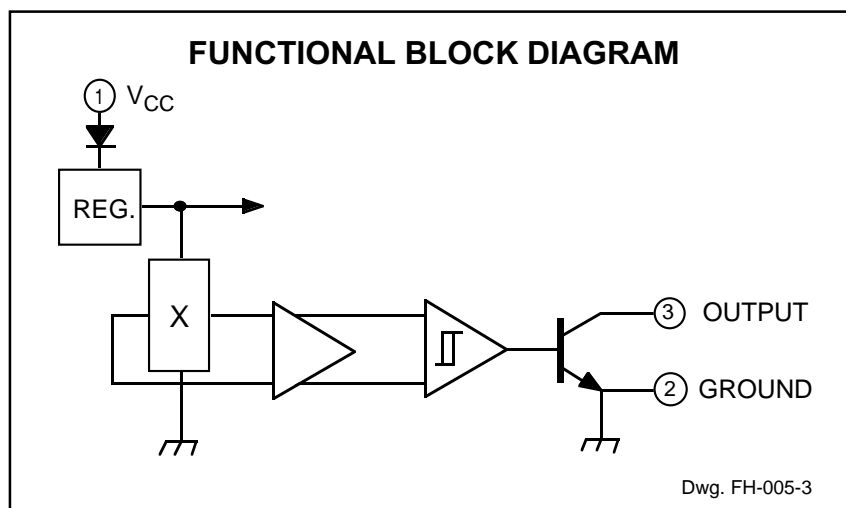

## ELECTRICAL CHARACTERISTICS over operating temperature range, at $V_{CC} = 12\text{ V}$ .

Characteristic	Symbol	Test Conditions	Limits			
			Min.	Typ.	Max.	Units
Supply Voltage	$V_{CC}$	Operating	3.8	—	24	V
Output Saturation Voltage	$V_{OUT(SAT)}$	$I_{OUT} = 20\text{ mA}$ , $B > B_{OP}$	—	175	400	mV
Output Leakage Current	$I_{OFF}$	$V_{OUT} = 24\text{ V}$ , $B < B_{RP}$	—	0.05	5.0	$\mu\text{A}$
Supply Current	$I_{CC}$	$B < B_{RP}$ (Output OFF)	—	4.75	8.0	mA
		$B > B_{OP}$ (Output ON)	—	5.7	—	mA
Output Rise Time	$t_r$	$R_L = 820\ \Omega$ , $C_L = 20\text{ pF}$	—	100	—	ns
Output Fall Time	$t_f$	$R_L = 820\ \Omega$ , $C_L = 20\text{ pF}$	—	100	—	ns

## MAGNETIC CHARACTERISTICS in gauss over operating supply voltage range.

Characteristic	Part Numbers*							
	A3185		A3187		A3188		A3189	
	Min.	Max.	Min.	Max.	Min.	Max.	Min.	Max.
$B_{OP}$ at $T_A = 25^\circ\text{C}$	170	270	50	150	100	180	50	230
over operating temp. range	140	300	50	175	80	200	50	250
$B_{RP}$ at $T_A = 25^\circ\text{C}$	-270	-170	-150	-50	-180	-100	-230	-50
over operating temp. range	-300	-140	-175	-50	-200	-80	-250	-50
$B_{hys}$ at $T_A = 25^\circ\text{C}$	340	540	100	300	200	360	100	460
over operating temp. range	280	600	100	350	160	400	100	500

NOTES:  $B_{OP}$  = operate point (output turns ON);  $B_{RP}$  = release point (output turns OFF);  $B_{hys}$  = hysteresis ( $B_{OP} - B_{RP}$ ).

As used here, negative flux densities are defined as less than zero (algebraic convention).

\*Complete part number includes a suffix to identify operating temperature range (E or L) and package type (LT or UA).

# 3185 THRU 3189 HALL-EFFECT LATCHES FOR HIGH-TEMPERATURE OPERATION

## TYPICAL OPERATING CHARACTERISTICS

**A3185\* SWITCH POINTS**

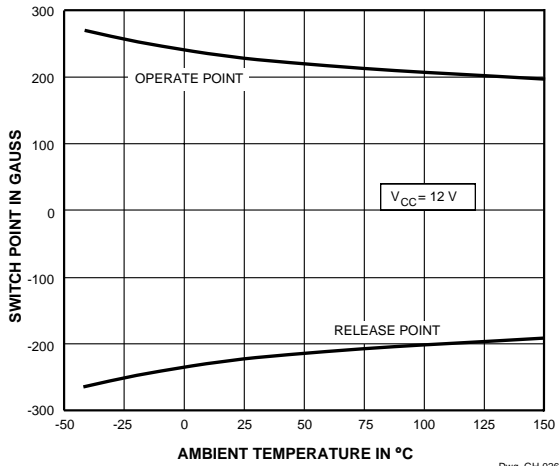

Dwg. GH-026

**A3187\* SWITCH POINTS**

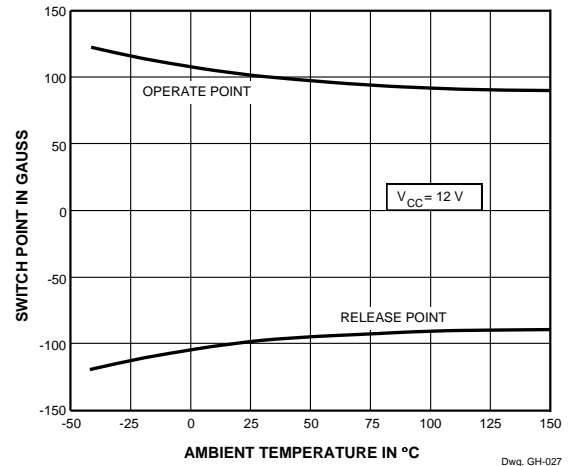

Dwg. GH-027

**OUTPUT SATURATION VOLTAGE**

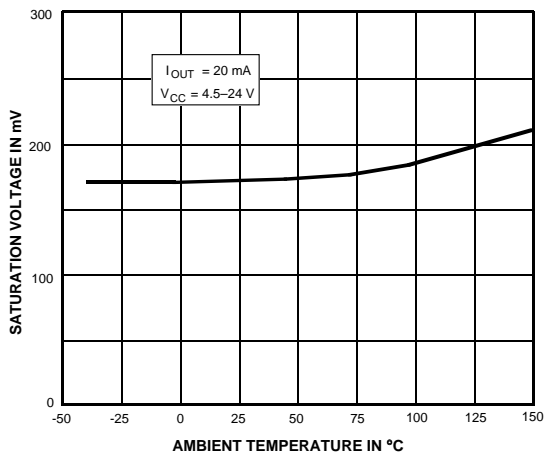

Dwg. GH-029

**SUPPLY CURRENT**

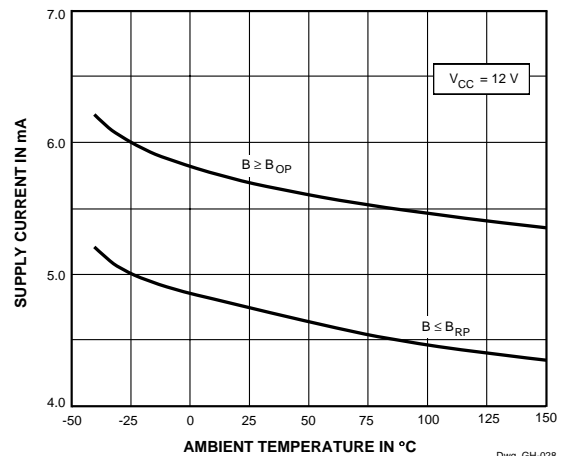

Dwg. GH-028

**SUPPLY CURRENT**

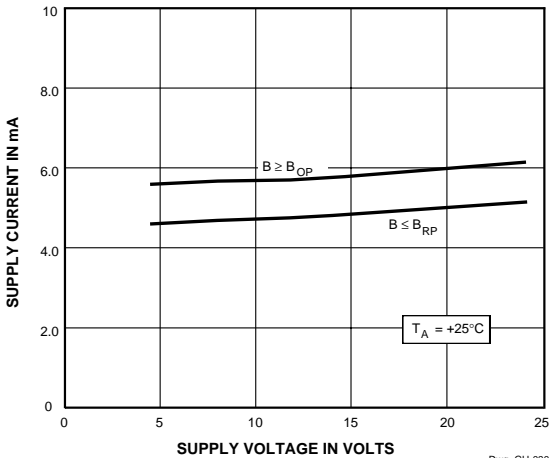

Dwg. GH-030

**OPERATE POINT**

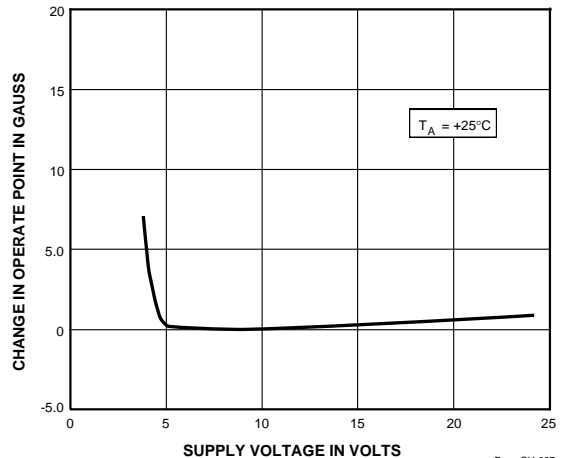

Dwg. GH-031

\* Complete part number includes a suffix denoting operating temperature range (E or L) and package type (LT or UA).

# 3185 THRU 3189 HALL-EFFECT LATCHES FOR HIGH-TEMPERATURE OPERATION

## SENSOR LOCATIONS

( $\pm 0.005$ " [0.13 mm] die placement)

### Package Designators "LT"

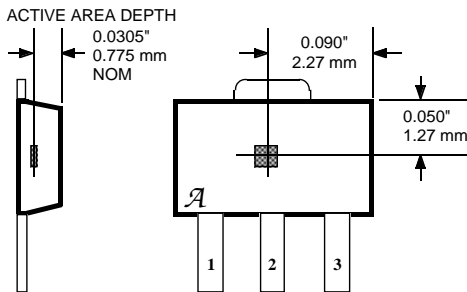

Dwg. MH-008-4C

### Package Designators "UA"

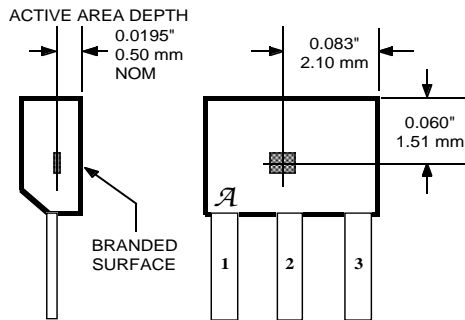

Dwg. MH-011-4C

Although sensor location is accurate to three sigma for a particular design, product improvements may result in small changes to sensor location.

## OPERATION

In operation, the output transistor is OFF until the strength of the magnetic field perpendicular to the surface of the chip exceeds the threshold or operate point ( $B_{OP}$ ). When the field strength exceeds  $B_{OP}$ , the output transistor switches ON and is capable of sinking 25 mA of current.

The output transistor switches OFF when magnetic field reversal results in a magnetic flux density below the OFF threshold ( $B_{RP}$ ). This is illustrated in the transfer characteristics graph (A3187\* shown).

Note that the device latches; that is, a south pole of sufficient strength will turn the device ON. Removal of the south pole will leave the device ON. The presence of a north pole of sufficient strength is required to turn the device OFF. Powering up in the absence of a magnetic field (less than  $B_{OP}$  and higher than  $B_{RP}$ ) will allow an indeterminate output state. The correct state is warranted after the first excursion beyond  $B_{OP}$  or  $B_{RP}$ .

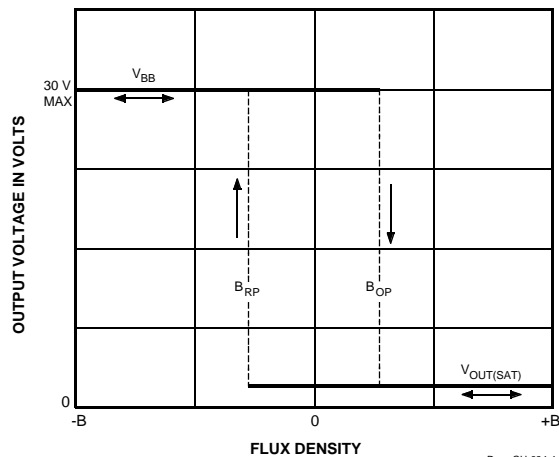

Dwg. GH-034-4

The simplest form of magnet that will operate these devices is a ring magnet, as shown below. Other methods of operation are possible.

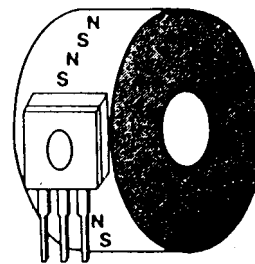

Dwg. A-11,899

## APPLICATIONS INFORMATION

Extensive applications information on magnets and Hall-effect sensors is also available in the *Allegro Integrated and Discrete Semiconductors Data Book* or *Application Note 27701*.

# 3185 THRU 3189 HALL-EFFECT LATCHES FOR HIGH-TEMPERATURE OPERATION

## PACKAGE DESIGNATOR 'LT' (SOT89/TO-243AA)

**Dimensions in Inches**  
(for reference only)

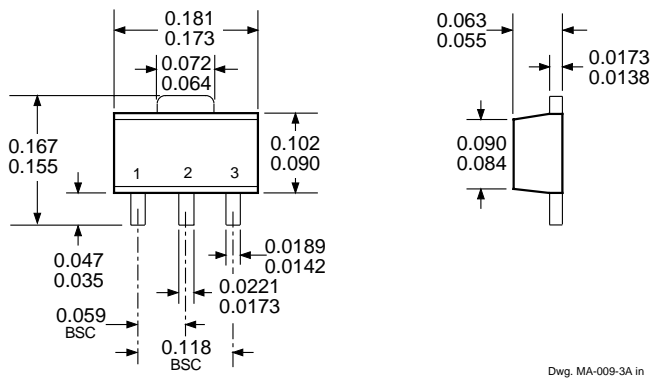

**Dimensions in Millimeters**  
(controlling dimensions)

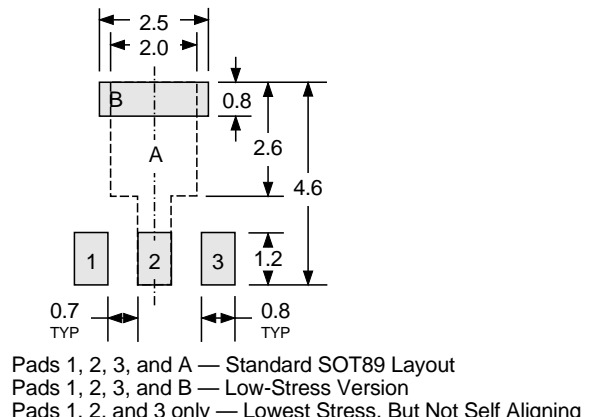
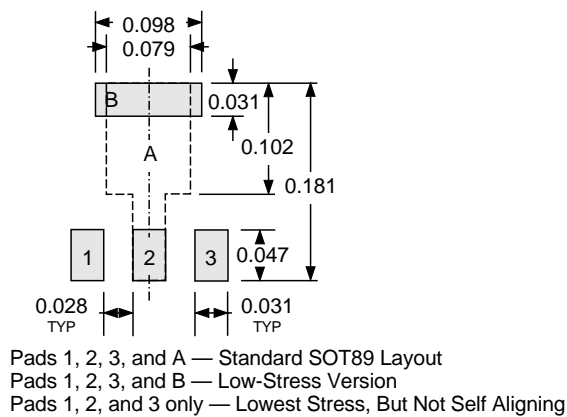
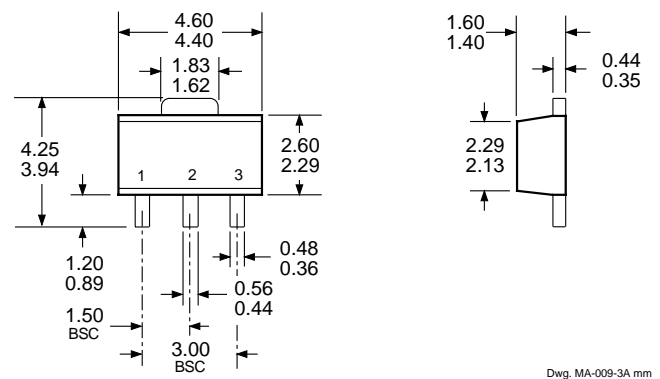

- NOTES:
1. Exact body and lead configuration at vendor's option within limits shown.
  2. Supplied in bulk pack (500 pieces per bag) or add "TR" to part number for tape and reel.
  3. Only low-temperature ( $\leq 240^{\circ}\text{C}$ ) reflow-soldering techniques are recommended for SOT89 devices.

# 3185 THRU 3189 HALL-EFFECT LATCHES FOR HIGH-TEMPERATURE OPERATION

## PACKAGE DESIGNATOR 'UA'

Dimensions in Inches  
(controlling dimensions)

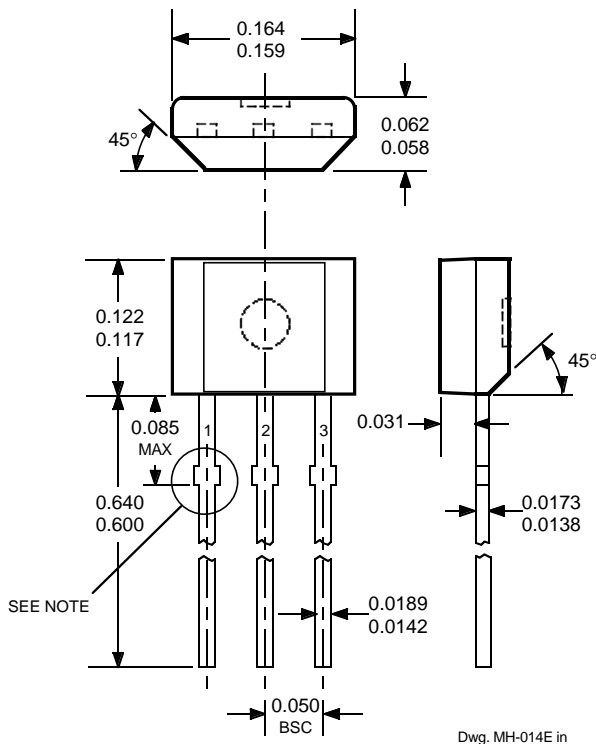

Dimensions in Millimeters  
(for reference only)

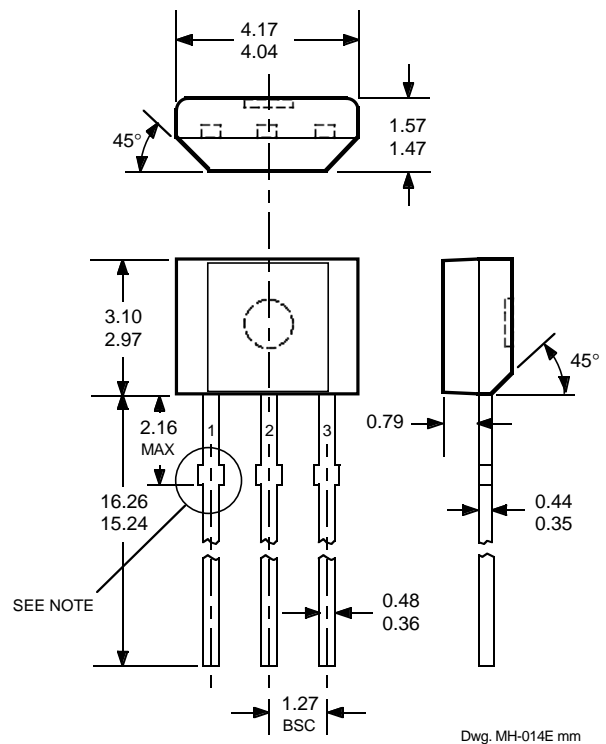

- NOTES:
1. Tolerances on package height and width represent allowable mold offsets. Dimensions given are measured at the widest point (parting line).
  2. Exact body and lead configuration at vendor's option within limits shown.
  3. Height does not include mold gate flash.
  4. Recommended minimum PWB hole diameter to clear transition area is 0.035" (0.89 mm).
  5. Where no tolerance is specified, dimension is nominal.
  6. Supplied in bulk pack (500 pieces per bag).

## Radial Lead Form (order A318xxUA-LC)

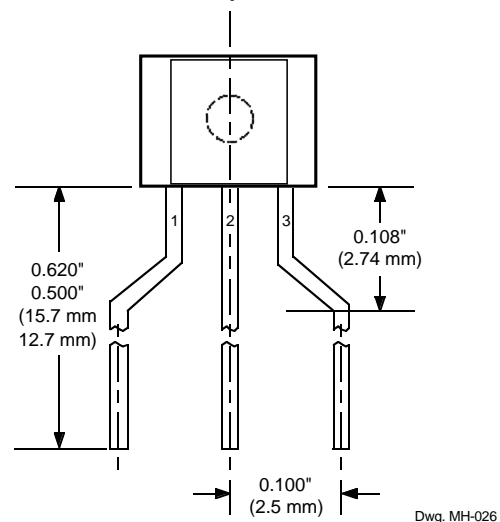

NOTE: Lead-form dimensions are the nominals produced on the forming equipment. No dimensional tolerance is implied or guaranteed for bulk packaging (500 pieces per bag).

**3185 THRU 3189**  
**HALL-EFFECT LATCHES**  
**FOR HIGH-TEMPERATURE**  
**OPERATION**

*The products described herein are manufactured under one or more of the following U.S. patents: 5,045,920; 5,264,783; 5,442,283; 5,389,889; 5,581,179; 5,517,112; 5,619,137; 5,621,319; 5,650,719; 5,686,894; 5,694,038; 5,729,130; 5,917,320; and other patents pending.*

*Allegro MicroSystems, Inc. reserves the right to make, from time to time, such departures from the detail specifications as may be required to permit improvements in the performance, reliability, or manufacturability of its products. Before placing an order, the user is cautioned to verify that the information being relied upon is current.*

*Allegro products are not authorized for use as critical components in life-support appliances, devices, or systems without express written approval.*

*The information included herein is believed to be accurate and reliable. However, Allegro MicroSystems, Inc. assumes no responsibility for its use; nor for any infringements of patents or other rights of third parties that may result from its use.*

---

**3185 THRU 3189**  
**HALL-EFFECT LATCHES**  
**FOR HIGH-TEMPERATURE**  
**OPERATION**

**HALL-EFFECT SENSORS**

LATCHING HALL-EFFECT DIGITAL SWITCHES						
Partial Part Number	Operate Point (G) Over Oper. Voltage	Release Point (G) & Temp. Range	Hysteresis (G) Range	Oper. Temp.	Packages	Replaces and Comments
UGN3175	15 to 180	-180 to -15	>80 (Typ 180)	S	LT, UA	
UGN3177	25 to 150	-150 to -25	>50 (Typ 180)	S	LT, UA	
A3185x	140 to 300	-300 to -140	280 to 600	E/L	LT, UA	
A3187x	50 to 175	-175 to -50	100 to 350	E/L	LT, UA	3077, 3175, 3177
A3188x	80 to 200	-200 to -80	160 to 400	E/L	LT, UA	
A3189x	50 to 250	-250 to -50	100 to 500	E/L	LT, UA	3075, 3076
A3280x	5 to 40	-40 to -5	10 to 80	E/L	LH, LT, UA	chopper stabilized
A3281x	15 to 90	-90 to -15	30 to 180	E/L	LH, LT, UA	chopper stabilized
A3283x	100 to 180	-180 to -100	<400 (Typ 300)	E/L	LH, LT, UA	chopper stabilized
"PROTECTED" LATCHING HALL-EFFECT DIGITAL SWITCHES						
Partial Part Number	Operate Point (G) Over Oper. Voltage	Release Point (G) & Temp. Range	Hysteresis (G) Range	Oper. Temp.	Packages	Comments
A3195x	40 to 200	-200 to -40	>110 (Typ 220)	E, L	U, LT	active pulldown
A3197x	40 to 200	-200 to -40	>110 (Typ 230)	E, L	U, LT	open-collector output

Notes: 1) Typical data is at  $T_A = +25^\circ\text{C}$  and nominal operating voltage.

2) "x" = Operating Temperature Range [suffix letter or (prefix)]: S (UGN) =  $-20^\circ\text{C}$  to  $+85^\circ\text{C}$ , E =  $-40^\circ\text{C}$  to  $+85^\circ\text{C}$ , J =  $-40^\circ\text{C}$  to  $+115^\circ\text{C}$ , K (UGS) =  $-40^\circ\text{C}$  to  $+125^\circ\text{C}$ , L (UGL) =  $-40^\circ\text{C}$  to  $+150^\circ\text{C}$ .