

N-CHANNEL SILICON POWER MOS-FET

Features

- High speed switching
- Low on-resistance
- No secondary breakdown
- Low driving power
- Avalanche-proof

Applications

- Switching regulators
- UPS (Uninterruptible Power Supply)
- DC-DC converters

Maximum ratings and characteristic Absolute maximum ratings

(Tc=25°C unless otherwise specified)

Item	Symbol	Rating	Unit
Drain-source voltage	V _{DS}	900	V
Continuous drain current	I _D	±10	A
Pulsed drain current	I _{D(puls)}	±40	A
Gate-source voltage	V _{GS}	±30	V
Repetitive or non-repetitive	IAR *2	10	A
Maximum Avalanche Energy	EAV *1	648	mJ
Max. power dissipation	P _D	310	W
Operating and storage temperature range	T _{ch} T _{stg}	+150 -55 to +150	°C

*1 L=11.9mH, V_{CC}=90V *2 T_{ch}≤150°C

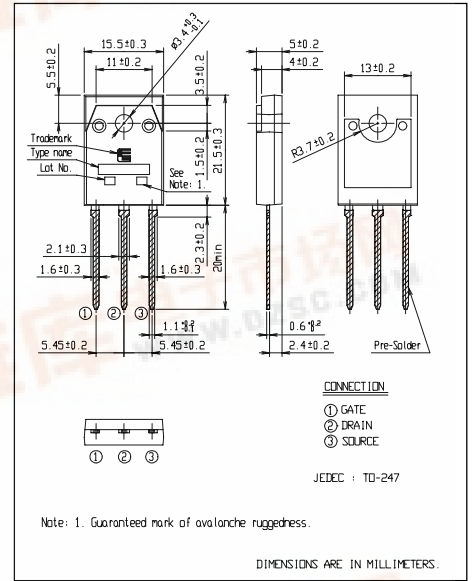

Equivalent circuit schematic

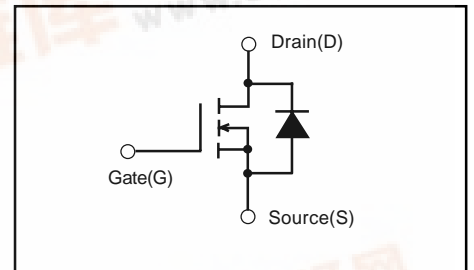

Electrical characteristics (Tc =25°C unless otherwise specified)

Item	Symbol	Test Conditions	Min.	Typ.	Max.	Units
Drain-source breakdown voltage	V _{(BR)DSS}	I _D =1mA V _{GS} =0V	900			V
Gate threshold voltage	V _{GS(th)}	I _D =1mA V _{DS} =V _{GS}	2.5	3.0	3.5	V
Zero gate voltage drain current	I _{DSS}	V _{DS} =900V V _{GS} =0V	T _{ch} =25°C	10	500	μA
			T _{ch} =125°C	0.2	1.0	mA
Gate-source leakage current	I _{GSS}	V _{GS} =±30V V _{DS} =0V		10	100	nA
Drain-source on-state resistance	R _{DS(on)}	I _D =5A V _{GS} =10V		0.92	1.2	Ω
Forward transconductance	g _{fs}	I _D =5A V _{DS} =25V	3.5	7		S
Input capacitance	C _{iss}	V _{DS} =25V		2200	3300	pF
Output capacitance	C _{oss}	V _{GS} =0V		240	360	pF
Reverse transfer capacitance	C _{rss}	f=1MHz		115	173	pF
Turn-on time t _{on}	t _{d(on)} t _r	V _{CC} =600V I _D =10A V _{GS} =10V		28	42	ns
				70	105	
Turn-off time t _{off}	t _{d(off)} t _f	R _{GS} =10Ω		220	330	ns
				90	135	
Total gate charge	Q _G	V _{CC} =450V		120	180	nC
Gate-Source charge	Q _{GS}	I _D =10A		36	54	nC
Gate-Drain charge	Q _{GD}	V _{GS} =10V		40	60	nC
Avalanche capability	I _{AV}	L=11.9mH T _{ch} =25°C	10			A
Diode forward on-voltage	V _{SD}	I _F =2I _{DR} V _{GS} =0V T _{ch} =25°C		1.00	1.50	V
Reverse recovery time	t _{rr}	I _F =I _{DR} V _{GS} =0V		1.8		μs
Reverse recovery charge	Q _{rr}	-dI _F /dt=100A/μs T _{ch} =25°C		21.0		μC

Thermal characteristics

Item	Symbol	Test Conditions	Min.	Typ.	Max.	Units
Thermal resistance	R _{th(ch-c)}	channel to case			0.403	°C/W
	R _{th(ch-a)}	channel to ambient			50.0	°C/W



Characteristics

