

High Speed Fiber Optic LED Driver

GENERAL DESCRIPTION

The ML6633 is a high speed fiber optic LED driver suited for networking applications up to 200 Mbps. The part is capable of driving up to 82mA of current through a fiber optic LED from an ECL level input signal. Its efficient output stage provides a high current that can be programmed for accurate absolute output level which insures precise launch power.

The LED driver's output stage provides a fast well matched rise and fall time through a unique differential output stage.

The ML6633 high speed fiber optic LED driver is implemented in BiCMOS process and is available in an 8-pin SOIC package.

FEATURES

- Data rates up to 200Mbps
- Current driven output for accurate launch power
- Programmable output current from 20mA to 82mA
- High Efficiency Output Stage
- Low EMI/RFI Noise
- ECL inputs
- Industrial temperature version available
- May be used with ML6622 quantizer

APPLICATIONS

- FDDI
- Fast Ethernet, 100BASE-FX
- ATM (SONET), 155Mbps
- Proprietary high-speed fiber optic data links

BLOCK DIAGRAM

*Some Packages Are Obsolete

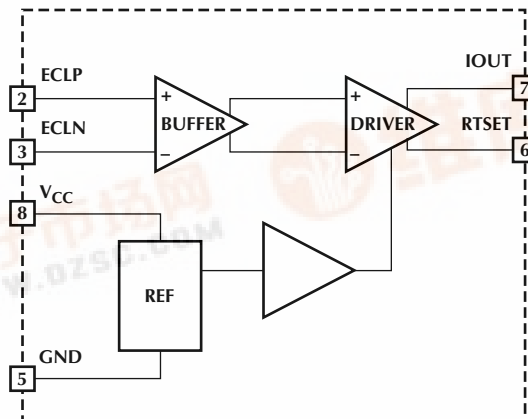

ML6633

PIN CONNECTION

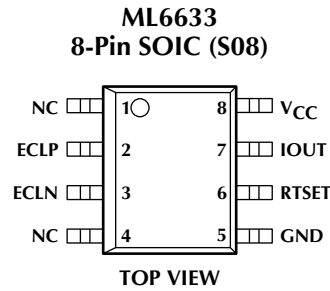

PIN DESCRIPTION

PIN	NAME	DESCRIPTION	PIN	NAME	DESCRIPTION
1	NC	No Connect	6	RTSET	Output current programming pin. Connect a resistor of value $2/I_{LED}$ from this pin to ground to set the high LED output current
2	ECLP	Positive ECL data input controls signal to the LED	7	IOOUT	Fiber optic LED drive pin. Connect the LED between this pin and V_{CC}
3	ECLN	Negative ECL data input	8	V_{CC}	5V power supply
4	NC	No Connect			
5	GND	Negative power supply ground			

ABSOLUTE MAXIMUM RATINGS

Absolute maximum ratings are those values beyond which the device could be permanently damaged. Absolute maximum ratings are stress ratings only and functional device operation is not implied.

V_{CC} GND -0.3V to 6V
 Input Pin Voltages GND -0.3V to V_{CC} +0.3V
 LED Output Current (IOUT) 82mA
 Peak DC Output Current (IOUT) 82mA

Storage Temperature -65°C to +150°C
 Lead Temperature (Soldering 10 sec) 260°C
 Thermal Resistance (θ_{JA}) 160°C/W

OPERATING CONDITIONS

Temperature Range
 ML6633CS 0°C to 70°C
 ML6633IS -40°C to 85°C

ELECTRICAL CHARACTERISTICS

Unless otherwise specified, $V_{CC} = 5V \pm 5\%$, $RTSET = 26.1\Omega \pm 1\%$, $T_A =$ Operating Temperature Range, (Note 1)

SYMBOL	PARAMETER	CONDITIONS	MIN	TYP	MAX	UNITS
I_{CC}	Supply Current				$40 + I_{OUT}$	mA
I_{LEDH}	LED Current Accuracy (IOUT) High	C Suffix	70	75	82	mA
		I Suffix	65	75	82	mA
I_{LEDL}	Low				0.1	mA
t_R	Rise Time (IOUT)				2	ns
t_F	Fall Time (IOUT)				2	ns
t_{PLH}	Propagation Delay (IOUT)	Low to High			10	ns
		High to Low			10	ns
t_{PWD}	Pulse Width Distortion (IOUT)				0.5	ns
I_{ECL}	ECL Input Current				20	μA

Note 1: Limits are guaranteed by 100% testing, sampling, or correlation with worst-case test conditions.

ML6633

FUNCTIONAL DESCRIPTION

The ML6633 accepts ECL input signals and generates a high speed, high accuracy output current which is independent of supply voltage variations. The output current is programmable up to 82mA.

The ECL input stage is a standard NPN differential pair with a common mode range of between 1V and 4.5V with a +5V supply. With this common mode range it is possible to convert the ECL inputs into TTL. If the ECLN input is biased up to the TTL switching level, the ECLP pin can be driven by a TTL or CMOS output. Figure 1b shows a circuit implementing this technique. This circuit may degrade pulse width distortion and should be checked for acceptable performance in this configuration.

Output current to the LED is set by connecting the appropriate resistance from RTSET to ground. The high level output voltage at RTSET will be 2.0V. The current in the external resistor will be equal to the current through the LED. The output current with RTSET set to 26.1Ω will be:

$$I_{LED(HIGH)} = \frac{2V}{RTSET} \quad (1)$$

$$I_{LED(HIGH)} = \frac{2V}{26.1\Omega} = 75mA$$

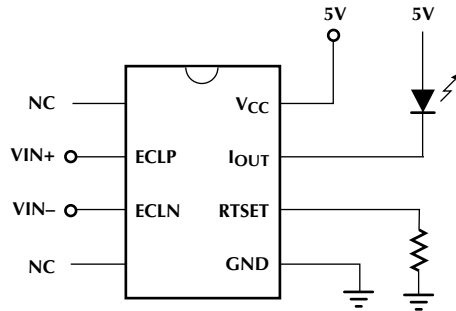

a) $I_{OUT} = 75mA$

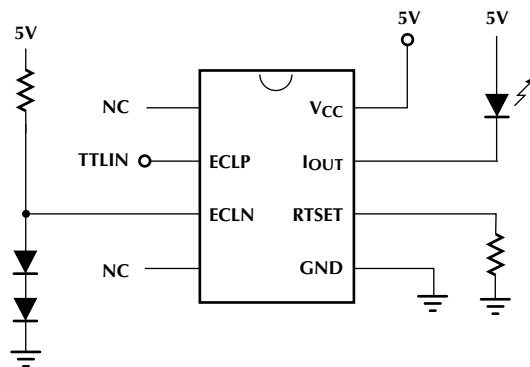

b) ECL-to-TTL Conversion

Figure 1. Typical Applications

ML6633

PHYSICAL DIMENSIONS inches (millimeters)

Package: S08
8-Pin SOIC

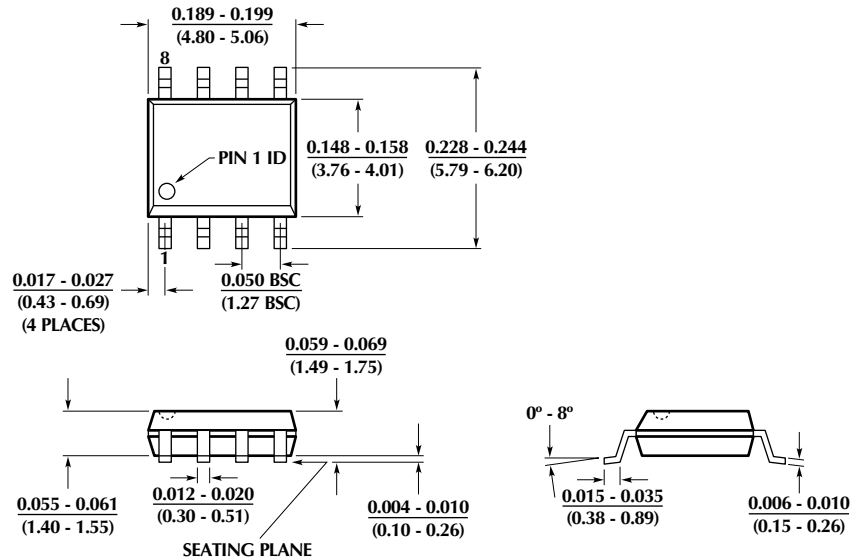

ORDERING INFORMATION

PART NUMBER	TEMPERATURE RANGE	PACKAGE
ML6633CS	0°C to 70°C	8-Pin SOIC (S08)
ML6633IS	-40°C to 85°C	8-Pin SOIC (S08) (Obolsete)

© Micro Linear 1998. Micro Linear is a registered trademark of Micro Linear Corporation. All other trademarks are the property of their respective owners.

Products described herein may be covered by one or more of the following U.S. patents: 4,897,611; 4,964,026; 5,027,116; 5,281,862; 5,283,483; 5,418,502; 5,508,570; 5,510,727; 5,523,940; 5,546,017; 5,559,470; 5,565,761; 5,592,128; 5,594,376; 5,652,479; 5,661,427; 5,663,874; 5,672,959; 5,689,167; 5,714,897; 5,717,798; 5,742,151; 5,747,977; 5,754,012; 5,757,174; 5,767,653; 5,777,514. Japan: 2,598,946; 2,619,299; 2,704,176. Other patents are pending.

Micro Linear reserves the right to make changes to any product herein to improve reliability, function or design. Micro Linear does not assume any liability arising out of the application or use of any product described herein, neither does it convey any license under its patent right nor the rights of others. The circuits contained in this data sheet are offered as possible applications only. Micro Linear makes no warranties or representations as to whether the illustrated circuits infringe any intellectual property rights of others, and will accept no responsibility or liability for use of any application herein. The customer is urged to consult with appropriate legal counsel before deciding on a particular application.

2092 Concourse Drive
San Jose, CA 95131
Tel: (408) 433-5200
Fax: (408) 432-0295
www.microlinear.com