

SANYO	No.1948B	2SC3775
		NPN Epitaxial Planar Silicon Transistor UHF Low-Noise Amp, Wide-Band Amp Applications

Applications

- . UHF low-noise amplifiers, wide-band amplifiers

Features

- . Small noise figure: NF=1.5dB typ(f=0.9GHz).
- . High power gain: MAG=14dB typ(f=0.9GHz).
- . High cutoff frequency: $f_T=5.0\text{GHz}$ typ.

Absolute Maximum Ratings at Ta=25°C

			unit
Collector to Base Voltage	V_{CB0}	20	V
Collector to Emitter Voltage	V_{CEO}	12	V
Emitter to Base Voltage	V_{EBO}	3	V
Collector Current	I_C	100	mA
Base Current	I_B	30	mA
Collector Dissipation	P_C	250	mW
Junction Temperature	T_J	150	°C
Storage Temperature	T_{stg}	-55 to +150	°C

Electrical Characteristics at Ta=25°C

		min	typ	max	unit
Collector Cutoff Current	I_{CB0} $V_{CB}=12V, I_E=0$			1.0	μA
Emitter Cutoff Current	I_{EBO} $V_{EB}=2V, I_C=0$			10	μA
DC Current Gain	h_{FE} $V_{CE}=10V, I_C=20mA$	40*		200*	
Gain-Bandwidth Product	f_T $V_{CE}=10V, I_C=20mA$		5.0		GHz
Output Capacitance	c_{ob} $V_{CB}=10V, f=1MHz$		0.9		pF
Reverse Transfer Capacitance	c_{re} $V_{CB}=10V, f=1MHz$		0.6		pF
Forward Transfer Gain	$ S_{21e} ^2$ $V_{CE}=10V, I_C=20mA, f=0.9GHz$	8.5	10		dB
Maximum Available Power Gain	MAG $V_{CE}=10V, I_C=20mA, f=0.9GHz$		14		dB
Noise Figure	NF $V_{CE}=10V, I_C=5mA, f=0.9GHz$	1.5	3.0		dB

See specified Test Circuit.

*: The 2SC3775 is classified by 20mA h_{FE} as follows:

40	2	80	60	3	120	100	4	200
----	---	----	----	---	-----	-----	---	-----

(Note) Marking :0Y
 h_{FE} rank :2,3,4

Package Dimensions 2018A

(unit:mm)

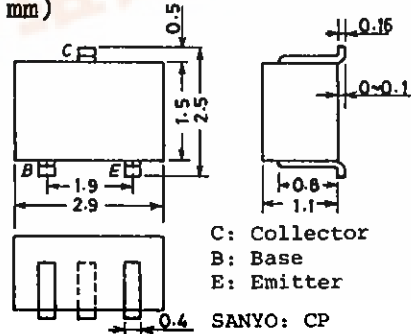

NF Test Circuit

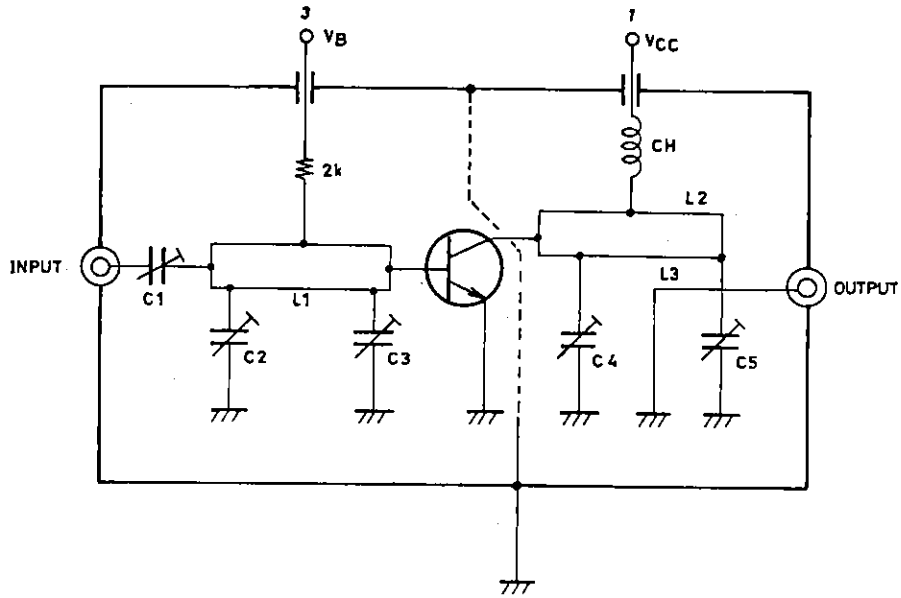
Unit (Resistance : Ω)

900MHz	
C1	~5 pF
C2	~10 pF
C3	~10 pF
C4	~10 pF
C5	~10 pF
L1	W \div 1.5mm, l \div 25mm strip line
L2	W \div 4mm, l \div 25mm strip line
L3	0.5 ϕ , l \div 40mm
CH	2t+bead core

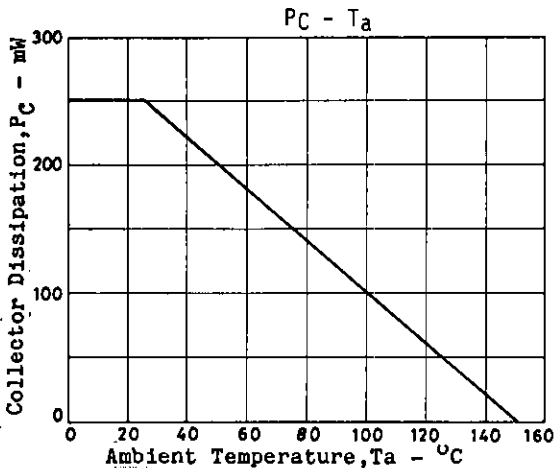
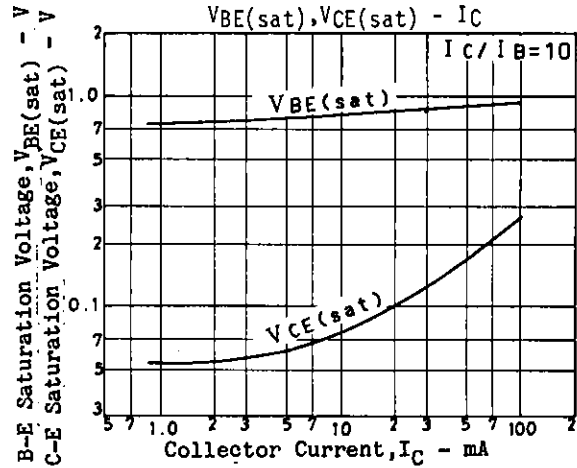
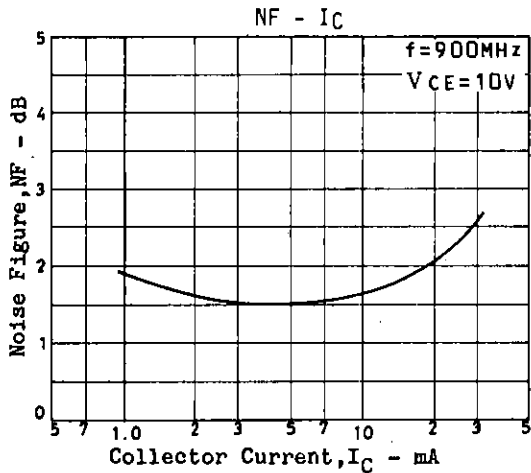
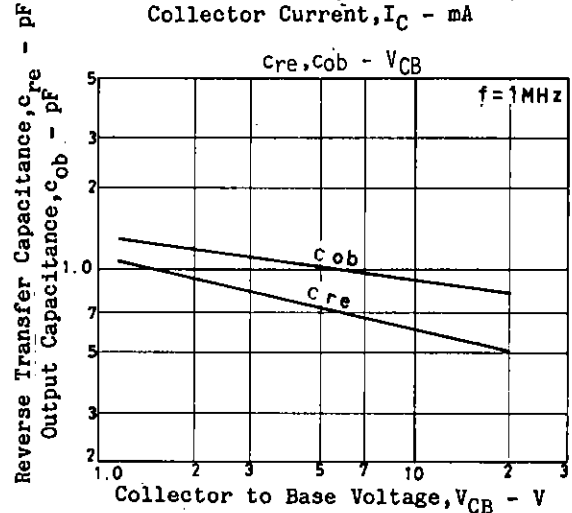
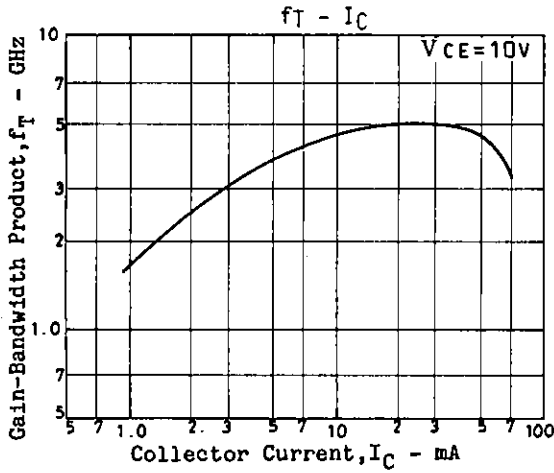
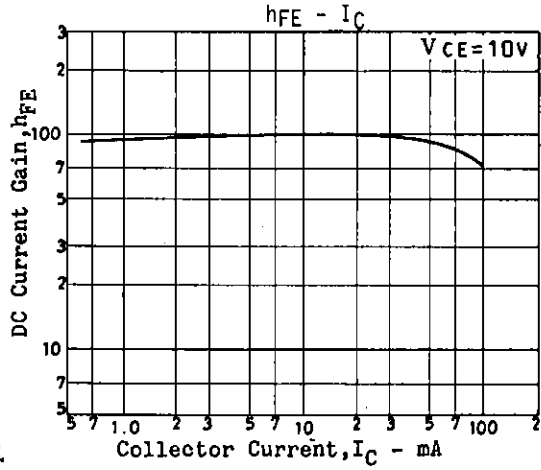
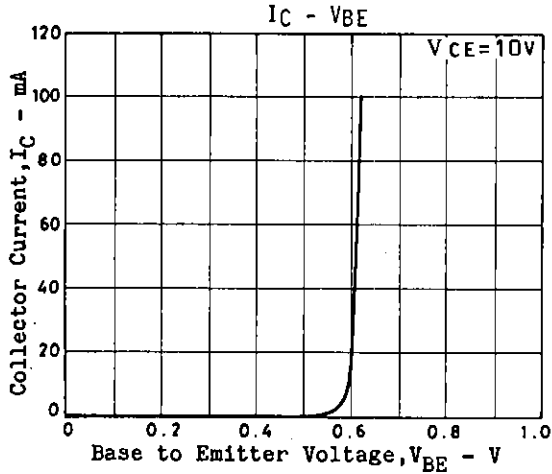

S11e : V_{CE}=10V
f=200MHz step

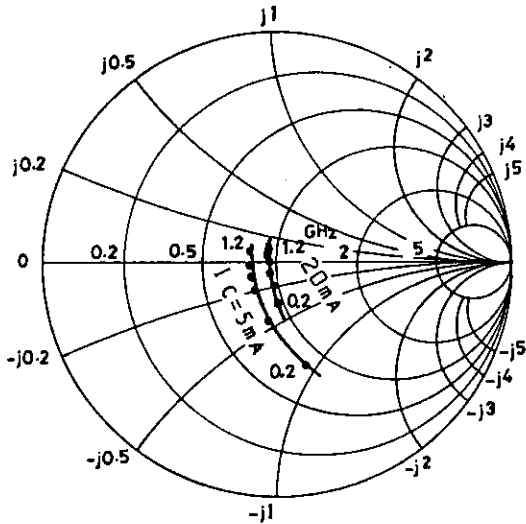

S12e : V_{CE}=10V
f=200MHz step

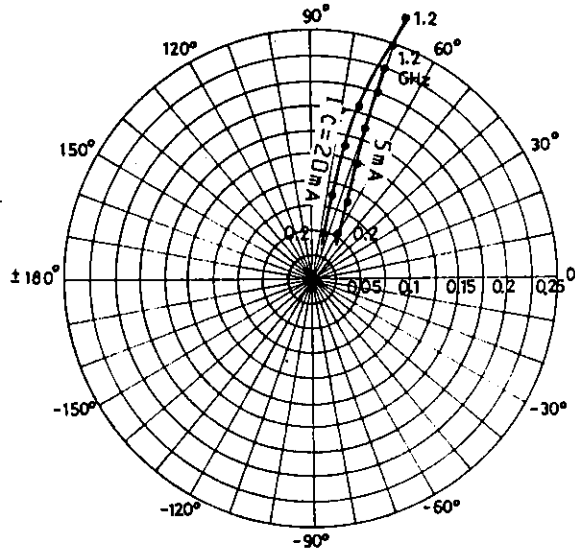

S21e : V_{CE}=10V
f=200MHz step

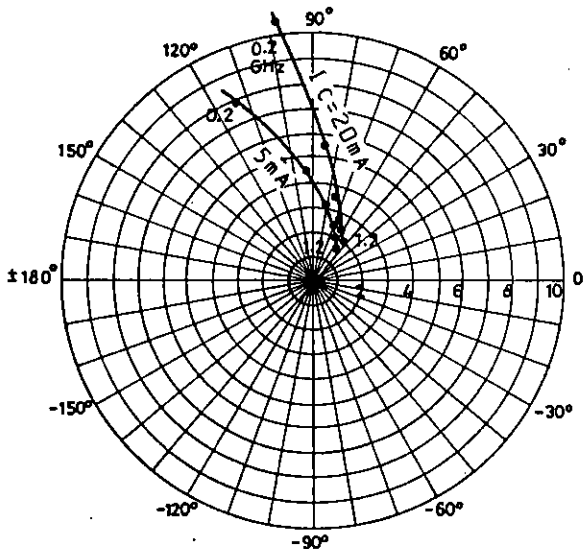

S22e : V_{CE}=10V
f=200MHz step

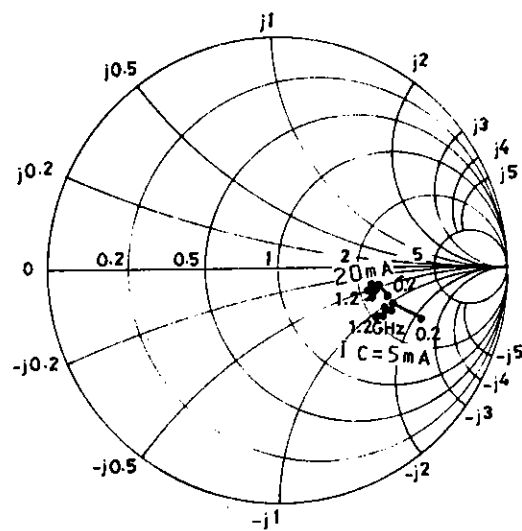

■ No products described or contained herein are intended for use in surgical implants, life-support systems, aerospace equipment, nuclear power control systems, vehicles, disaster/crime-prevention equipment and the like, the failure of which may directly or indirectly cause injury, death or property loss.

■ Anyone purchasing any products described or contained herein for an above-mentioned use shall:

- ① Accept full responsibility and indemnify and defend SANYO ELECTRIC CO., LTD., its affiliates, subsidiaries and distributors and all their officers and employees, jointly and severally, against any and all claims and litigation and all damages, cost and expenses associated with such use;
- ② Not impose any responsibility for any fault or negligence which may be cited in any such claim or litigation on SANYO ELECTRIC CO., LTD., its affiliates, subsidiaries and distributors or any of their officers and employees jointly or severally.

■ Information (including circuit diagrams and circuit parameters) herein is for example only; it is not guaranteed for volume production. SANYO believes information herein is accurate and reliable, but no guarantees are made or implied regarding its use or any infringements of intellectual property rights or other rights of third parties.