

MOS INTEGRATED CIRCUIT

μ PD75238

4 BIT SINGLE-CHIP MICROCOMPUTER

The μ PD75238 is a single-chip microcomputer which contains a CPU capable of 1-, 4-, and 8-bit data processing, ROM, RAM, and I/O ports. In addition, it contains a fluorescent display tube (FIP²) controller/driver, A/D converter, clock timer, timer/pulse generator capable of 14-bit PWM output, serial interface, and vectored interrupt function.

In comparison with the μ PD75217, the μ PD75238 has larger ROM and RAM capacity and has been enhanced in such peripheral facilities as the display function of the FIP controller/driver, I/O ports, A/D converter, serial interface.

The μ PD75238 finds best use in such applications as timer/tuner of VCRs from advanced type to common type, configuration of one-chip system control microcomputer, advanced CD player, advanced microwave ovens, etc.

With the μ PD75238, the μ PD75P238, which is a PROM product, and various development tools including IE-75001-R and assemblers are available. They can be used for evaluation during system development and small-volume production.

FEATURES

- Mass-storage built-in ROM and RAM
 - Program memory (ROM): 32K \times 8
 - Data memory (RAM) : 1K \times 4
- I/O port: 64 lines (excluding pins dedicated to FIP)
- Minimum instruction execution time: 0.67 μ s (at 6.0 MHz)
- Instruction execution time specification function to allow a wide range of operating voltages
- Programmable FIP controller/driver contained
 - Number of segments: 9 to 24 segments
 - Number of digits : 9 to 16 digits
- 8-bit A/D converter: 8 channels
- Enhanced timer/counter function: 5 channels
- 8-bit serial interface: 2 channels
- Application-oriented interrupt functions
- PROM version device: μ PD75P238

ORDERING INFORMATION

Part number	Package	Quality grade
μ PD75238GJ-xxx-5BG	94-pin plastic QFP (20 \times 20 mm)	Standard

Please refer to "Quality Grade on NEC Semiconductor Devices" (Document number IEI-1209) published by NEC Corporation to know the specification of quality grade on the devices and its recommended applications.



FUNCTIONS

Item	Function
On-chip memory	ROM: 32640 × 8 bits, RAM: 1024 × 4 bits
I/O lines (Excluding pins dedicated to FIP)	64 lines { <ul style="list-style-type: none"> • Input : 16 lines • I/O : 24 lines • Output: 24 lines
Instruction cycle	<ul style="list-style-type: none"> • 0.67 μs/1.33 μs/2.67 μs/10.7 μs (at 6.0 MHz) • 0.95 μs/1.91 μs/3.82 μs/15.3 μs (at 4.19 MHz) • 122 μs (at 32.768 kHz)
Fluorescent display tube (FIP) controller/driver	<ul style="list-style-type: none"> • Number of segments : 9 to 24 segments • Number of digits : 9 to 16 digits • Dimmer function : 8 levels • Pull-down resistors provided by mask option • Key scan interrupt generator
Timer/counter	5 channels { <ul style="list-style-type: none"> • Basic interval timer : Usable as watchdog timer • Timer/event counter • Clock timer : With buzzer output function • Timer/pulse generator: With 14-bit PWM output function • Event counter
Serial interface	2 channels { <ul style="list-style-type: none"> • SBI or 3-wire mode • 3-wire mode
Interrupt	<ul style="list-style-type: none"> • Allows multiple hardware interrupts. • External interrupts: 3 { <ul style="list-style-type: none"> • Detection of both edges • Detection edge programmable (with noise elimination) • Detection edge programmable • External test input: 1 { <ul style="list-style-type: none"> • Rising edge detection • Internal interrupts : 5 { <ul style="list-style-type: none"> • Timer/pulse generator • Timer/event counter • Basic interval timer • Serial interface #0 • For key scanning • Internal test inputs: 2 { <ul style="list-style-type: none"> • Clock timer • Serial interface #1
System clock oscillator	<ul style="list-style-type: none"> • Main system clock: 6.0 MHz, 4.19 MHz • Subsystem clock : 32.768 kHz, standard
Mask option	<ul style="list-style-type: none"> • High-voltage port: Pull-down resistor or open-drain output • Ports 4 and 5 : Pull-up resistor • Port 7 : Pull-down resistor
Operating temperature	-40 to +85 °C
Operating voltage	2.7 to 6.0 V (Data held in standby mode: 2.0 to 6.0 V)
Package	94-pin plastic QFP (20 × 20 mm)

PIN CONFIGURATION

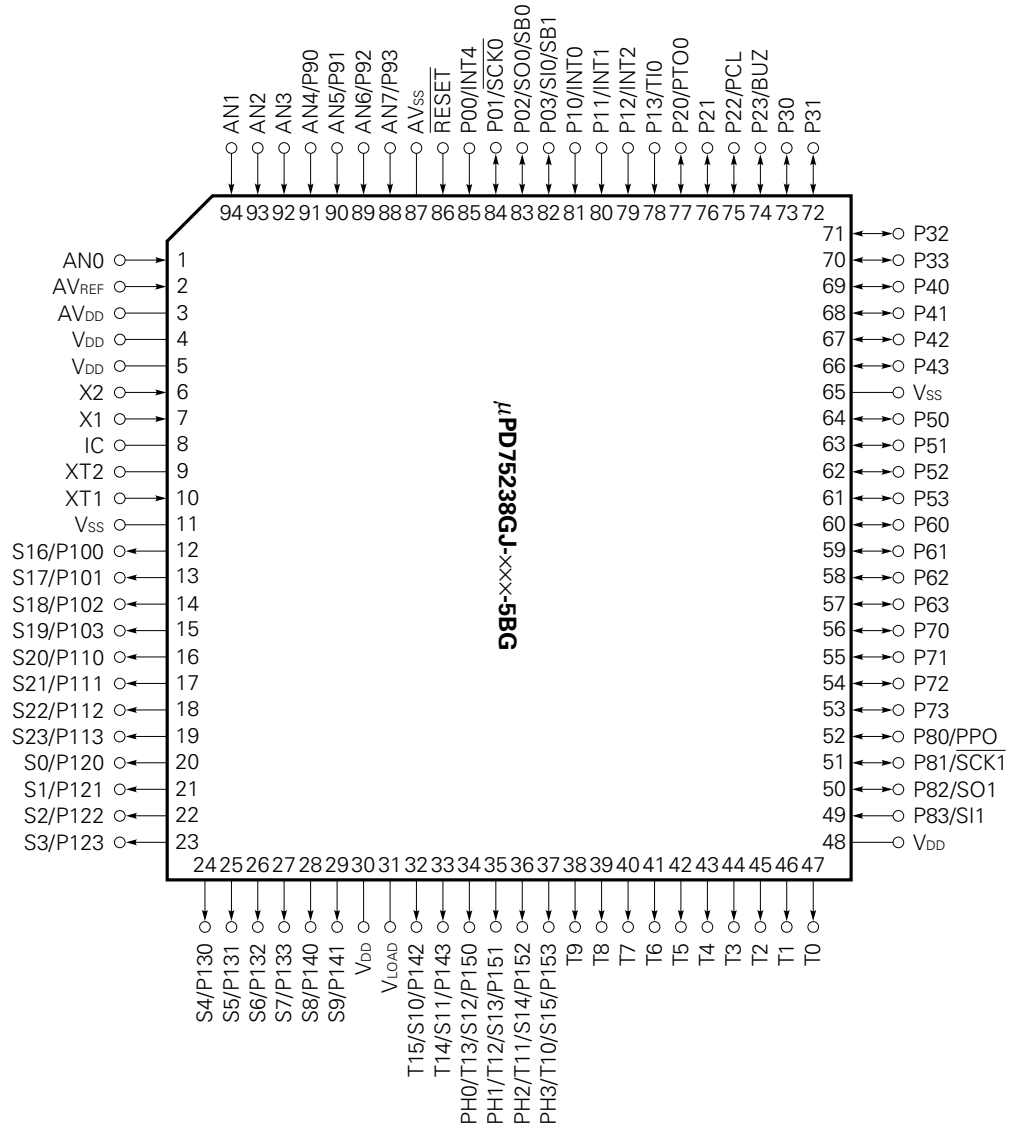

Caution Be sure to supply power to the AVDD, VDD, VSS, and AVSS pins (pins 3, 4, 5, 11, 30, 48, 65, and 87).

Remark IC: Internally connected pin (to be grounded)

BLOCK DIAGRAM

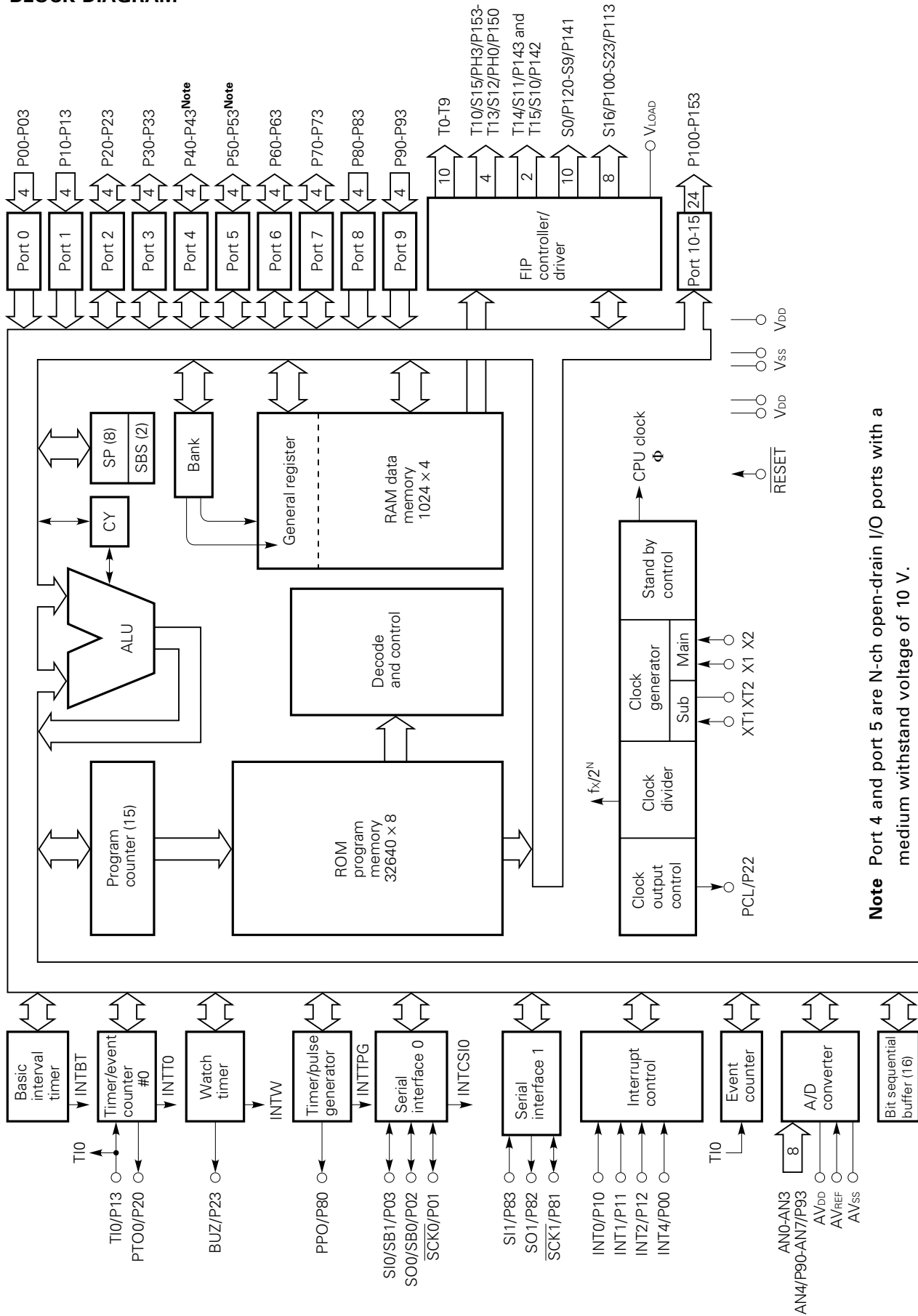

Note Port 4 and port 5 are N-ch open-drain I/O ports with a medium withstand voltage of 10 V.

CONTENTS

1. PIN FUNCTIONS	7
1.1 PORT PINS	7
1.2 NON-PORT PINS	9
1.3 PIN INPUT/OUTPUT CIRCUITS	11
1.4 CONNECTION OF UNUSED μPD75238 PINS	15
2. ARCHITECTURE AND MEMORY MAP OF THE μPD75238	16
2.1 DATA MEMORY BANK CONFIGURATION AND ADDRESSING MODES	16
2.2 GENERAL REGISTER BANK CONFIGURATION	19
2.3 MEMORY-MAPPED I/O	22
3. INTERNAL CPU FUNCTIONS	27
3.1 PROGRAM COUNTER (PC)	27
3.2 PROGRAM MEMORY (ROM)	27
3.3 DATA MEMORY (RAM)	29
3.4 GENERAL REGISTERS	31
3.5 ACCUMULATORS	32
3.6 STACK POINTER (SP) AND STACK BANK SELECT REGISTER (SBS)	32
3.7 PROGRAM STATUS WORD (PSW)	35
3.8 BANK SELECT REGISTER (BS)	39
4. PERIPHERAL HARDWARE FUNCTIONS	40
4.1 DIGITAL I/O PORTS	40
4.2 CLOCK GENERATOR	49
4.3 CLOCK OUTPUT CIRCUIT	58
4.4 BASIC INTERVAL TIMER	61
4.5 TIMER/EVENT COUNTER	63
4.6 CLOCK TIMER	69
4.7 TIMER/PULSE GENERATOR	71
4.8 EVENT COUNTER	77
4.9 SERIAL INTERFACE	79
4.10 A/D CONVERTER	113
4.11 BIT SEQUENTIAL BUFFER	119
4.12 FIP CONTROLLER/DRIVER	119
5. INTERRUPT FUNCTION	131
5.1 CONFIGURATION OF THE INTERRUPT CONTROL CIRCUIT	131
5.2 HARDWARE OF THE INTERRUPT CONTROL CIRCUIT	133
5.3 INTERRUPT SEQUENCE	138
5.4 MULTIPLE INTERRUPT PROCESSING CONTROL	139
5.5 VECTOR ADDRESS SHARE INTERRUPT PROCESSING	141

6.	STANDBY FUNCTION	142
6.1	SETTING OF STANDBY MODES AND OPERATION STATUSES	142
6.2	RELEASE OF THE STANDBY MODES	144
6.3	OPERATION AFTER A STANDBY MODE IS RELEASED	146
7.	RESET FUNCTION	147
8.	INSTRUCTION SET	150
8.1	μPD75238 INSTRUCTIONS	150
8.2	INSTRUCTION SET AND ITS OPERATION	153
8.3	INSTRUCTION CODES OF EACH INSTRUCTION	162
9.	SPECIFICATION OF MASK OPTIONS	168
10.	APPLICATION BLOCK DIAGRAM	169
11.	ELECTRICAL CHARACTERISTICS	170
★	12. CHARACTERISTIC CURVES (FOR REFERENCE)	181
13.	PACKAGE DIMENSIONS	183
14.	RECOMMENDED SOLDERING CONDITIONS	184
APPENDIX A	μPD75238 SERIES PRODUCT FUNCTION LIST	185
APPENDIX B	DEVELOPMENT TOOLS	186

1. PIN FUNCTIONS

1.1 PORT PINS (1/2)

Pin name	I/O	Also used as	Function	8-bit I/O	When reset	I/O ^{Note 1} circuit type
P00	I	INT4	4-bit input port (port 0). For P01 to P03, pull-up resistors can be provided by software in units of 3 bits.	×	Input	Ⓟ
P01		$\overline{\text{SCK0}}$				Ⓢ - A
P02		SO0/SB0				Ⓢ - B
P03		SI0/SB1				M - C
P10	I	INT0	4-bit input port (port 1). Pull-up resistors can be provided by software in units of 4 bits.	×	Input	Ⓟ - C
P11		INT1				
P12		INT2				
P13		TI0				
P20	I/O	PTO0	4-bit I/O port (port 2). Pull-up resistors can be provided by software in units of 4 bits.	×	Input	E - B
P21		–				
P22		PCL				
P23		BUZ				
P30 ^{Note 2}	I/O	–	Programmable 4-bit I/O port (port 3). Input/output can be specified bit by bit. Pull-up resistors can be provided by software in units of 4 bits.	×	Input	E - C
P31 ^{Note 2}		–				
P32 ^{Note 2}		–				
P33 ^{Note 2}		–				
P40-P43 ^{Note 2}	I/O	–	N-ch open-drain 4-bit I/O port (port 4). A pull-up resistor can be provided bit by bit (mask option). Withstand voltage is 10 V in open-drain mode.	○	High level (when a pull-up resistor is provided) or high impedance	M
P50-P53 ^{Note 2}						
P60	I/O	–	Programmable 4-bit I/O port (port 6). Input/output can be specified bit by bit. Pull-up resistors can be provided by software in units of 4 bits.	○	Input	E - C
P61		–				
P62		–				
P63		–				
P70	I/O	–	4-bit I/O port (port 7). A pull-down resistor can be provided bit by bit (mask option).		V _{ss} level (when a pull-down resistor is provided) or high impedance	V
P71		–				
P72		–				
P73		–				

- Notes** 1. The circuits enclosed in circles have a Schmitt-triggered input.
 2. An LED can be driven directly.

1.1 PORT PINS (2/2)

Pin name	I/O	Also used as	Function	8-bit I/O	When reset	I/O Note circuit type
P80	I/O	PPO	4-bit input port (port 8).	×	Input	A
P81	I/O	SCK1				Ⓣ
P82	I/O	SO1				E
P83	I	SI1				ⓑ
P90	I	AN4	4-bit input port (port 9)	×	Input	Y - A
P91		AN5				
P92		AN6				
P93		AN7				
P100	O	S16	P-ch open-drain, 4-bit high-voltage output port. Pull-down resistors can be provided (mask option).	○	V _{LOAD} level (when pull-down resistor to V _{LOAD} is provided), V _{SS} level (when pull-down resistor to V _{SS} is provided), or high-impedance	I - F
P101		S17				
P102		S18				
P103		S19				
P110	O	S20	P-ch open-drain, 4-bit high-voltage output port. Pull-down resistors can be provided (mask option).	○	V _{LOAD} level (when pull-down resistor to V _{LOAD} is provided) or high-impedance	I - C
P111		S21				
P112		S22				
P113		S23				
P120	O	S0	P-ch open-drain, 4-bit high-voltage output port. Pull-down resistors can be provided (mask option).	○	V _{LOAD} level (when pull-down resistor to V _{LOAD} is provided) or high-impedance	I - C
P121		S1				
P122		S2				
P123		S3				
P130	O	S4	P-ch open-drain, 4-bit high-voltage output port. Pull-down resistors can be provided (mask option).	○	V _{LOAD} level (when pull-down resistor to V _{LOAD} is provided) or high-impedance	I - C
P131		S5				
P132		S6				
P133		S7				
P140	O	S8	P-ch open-drain, 4-bit high-voltage output port. Pull-down resistors can be provided (mask option). P142 and P143 can drive LED directly.	○	V _{LOAD} level (when pull-down resistor to V _{LOAD} is provided) or high-impedance	I - C
P141		S9				
P142		S10/T15				
P143		S11/T14				
P150	O	S12/T13/PH0	P-ch open-drain, 4-bit high-voltage output port. Pull-down resistors can be provided (mask option). LED can be driven directly.	○	V _{LOAD} level (when pull-down resistor to V _{LOAD} is provided) or high-impedance	I - C
P151		S13/T12/PH1				
P152		S14/T11/PH2				
P153		S15/T10/PH3				
PH0	O	S12/T13/P150	P-ch open-drain, 4-bit high-voltage output port. Pull-down resistors can be provided (mask option).	×	V _{LOAD} level (when pull-down resistor to V _{LOAD} is provided) or high-impedance	I - C
PH1		S13/T12/P151				
PH2		S14/T11/P152				
PH3		S15/T10/P153				

Note The circuits enclosed in circles have a Schmitt-triggered input.

1.2 NON-PORT PINS (1/2)

Pin name	I/O	Also used as	Function		When reset	I/O circuit type	
T0-T9	O	–	Output pins for FIP controller/driver. Allows pull-down resistor to be provided (mask option).	High-voltage, large-current output for digit output	V _{LOAD} level (when pull-down resistor to V _{LOAD} is provided) or high-impedance	I - C	
T10/S15-T13/S12		PH3/P153-PH0/P150		High-voltage, large-current output usable for digit/segment output as well. Any unused pins can be used for port H. Usable for port 15 in static mode.			
T14/S11		P143		High-voltage, large-current output usable for digit/segment output as well. Usable for port 14 in static mode.			
T15/S10		P142		High-voltage, large-current output usable for digit/segment output as well. Usable for port 14 in static mode.			
S0-S3		P120-P123		High-voltage output for segment output. Usable for port 12 to port 14 in static mode.			
S4-S7		P130-P133					
S8		P140					
S9		P141					
S16-S19		P100-P103					High-voltage output for segment output. Usable for port 10 and port 11 in static mode.
S20-S23		P110-P113		V _{LOAD} level (when pull-down resistor to V _{LOAD} is provided), V _{SS} level (when pull-down resistor to V _{SS} is provided), or high-impedance			

1.2 NON-PORT PINS (2/2)

Pin name	I/O	Also used as	Function	When reset	I/O ^{Note} circuit type
TI0	I	P13	External event pulse input for timer/event counter #0 and event counter #1.	-	ⓑ - C
PTO0	O	P20	Timer/event counter output	Input	E - B
PCL	O	P22	Clock output	Input	E - B
BUZ	O	P23	Fixed frequency output (for buzzer or system clock trimming)	Input	E - B
$\overline{\text{SCK0}}$	I/O	P01	Serial clock I/O	Input	ⓕ - A
SO0/SB0	I/O	P02	Serial data output or serial bus I/O	Input	ⓕ - B
SI0/SB1	I/O	P03	Serial data input or serial bus I/O	Input	M - C
INT4	I	P00	Edge detection vectored interrupt input (Either a rising or falling edge is detected.)	-	ⓑ
INT0	I	P10	Edge detection vectored interrupt input (The edge to be detected is selectable.)	Synchronous	ⓑ - C
INT1		P11		Asynchronous	
INT2	I	P12	Edge detection testable input (An rising edge is detected.)	-	ⓑ - C
$\overline{\text{SCK1}}$	I/O	P81	Serial clock I/O	Input	ⓕ
SO1	O	P82	Serial data output	Input	E
SI1	I	P83	Serial data input	Input	ⓑ
AN0-AN3	I	-	Analog input to A/D converter	-	Y
AN4-AN7		P90-P93			Y - A
AV _{DD}	-	-	Power supply for A/D converter	-	-
AV _{REF}	I	-	A/D converter reference voltage input	-	Z
AV _{SS}	-	-	A/D converter reference GND	-	-
X1, X2	I	-	Connection to a crystal/ceramic resonator for main system clock generation. When external clock is used, it is input to X1, and its inverted signal is input to X2.	-	-
XT1	I	-	Connection to a crystal resonator for subsystem clock generation. When external clock is used, it is input to XT1, and XT2 is left open.	-	-
XT2	-				
$\overline{\text{RESET}}$	I	-	System reset input	-	ⓑ
PPO	O	P80	Timer/pulse generator pulse output	Input	-
V _{DD} (3 pins)	-	-	Positive power supply	-	-
V _{SS} (2 pins)	-	-	GND potential	-	-
V _{LOAD}	-	-	Pull-down resistor connection for the FIP controller/driver, or power supply	-	-

Note The circuits enclosed in circles have a Schmitt-triggered input.

1.3 PIN INPUT/OUTPUT CIRCUITS (1/4)

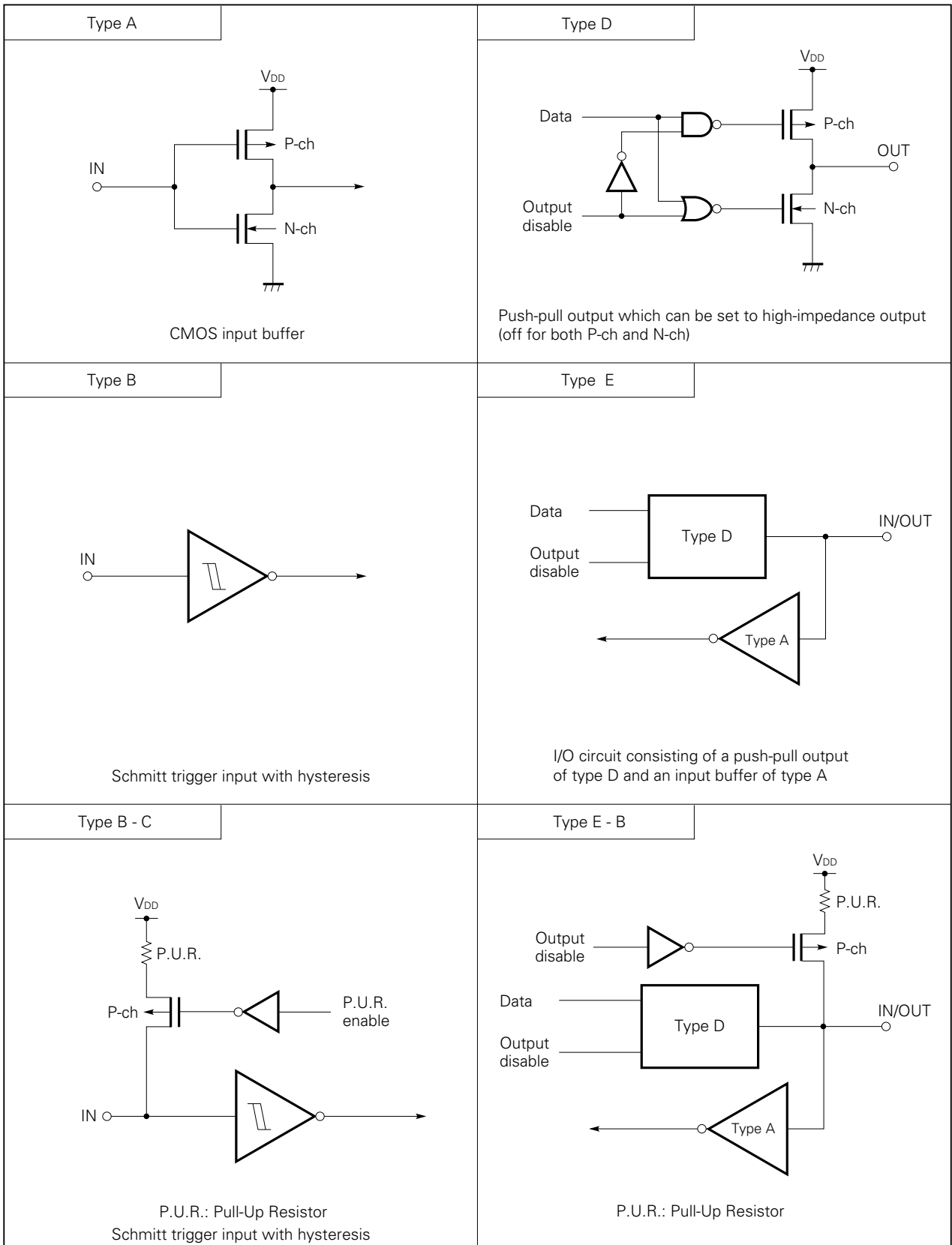

1.3 PIN INPUT/OUTPUT CIRCUITS (2/4)

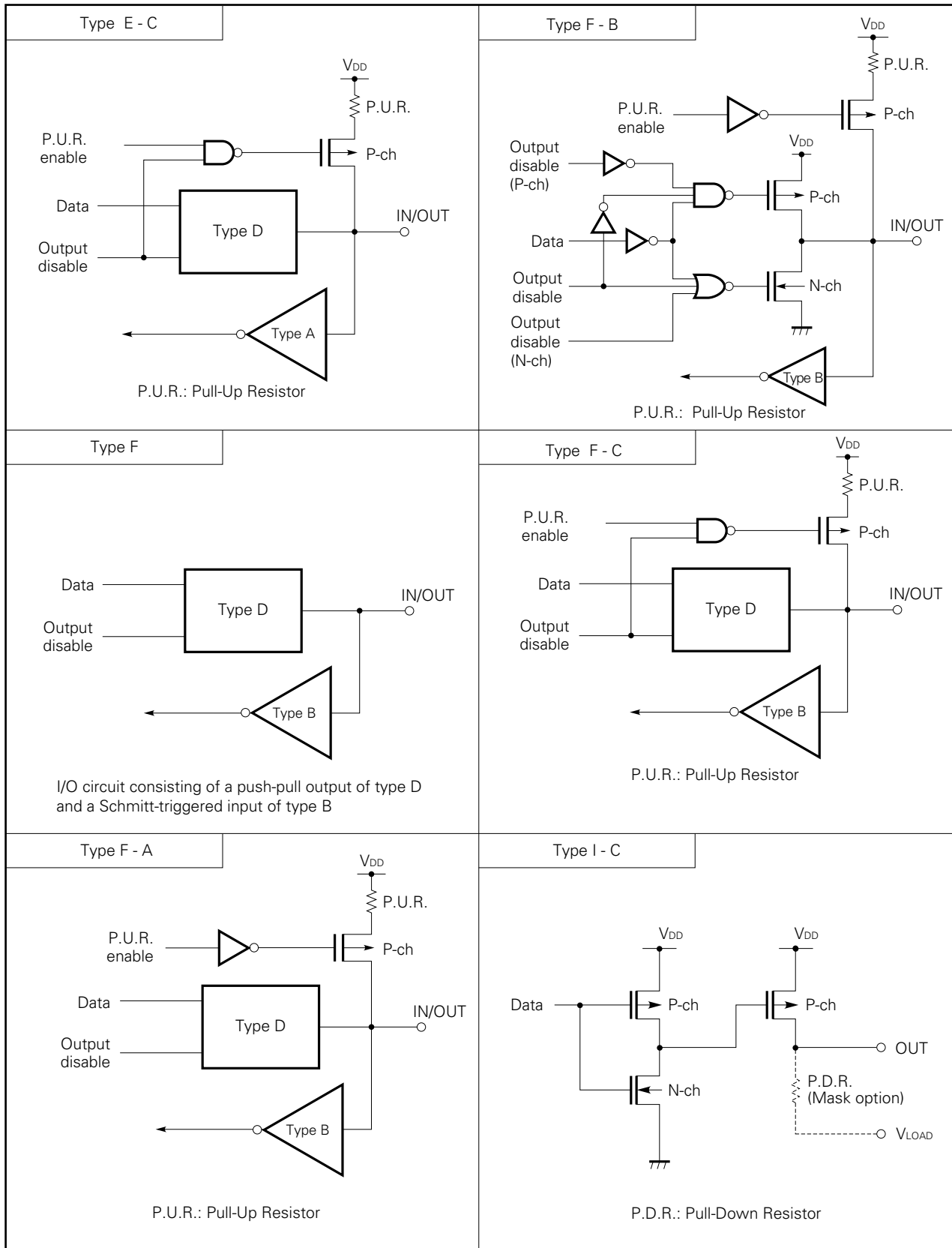

1.3 PIN INPUT/OUTPUT CIRCUITS (3/4)

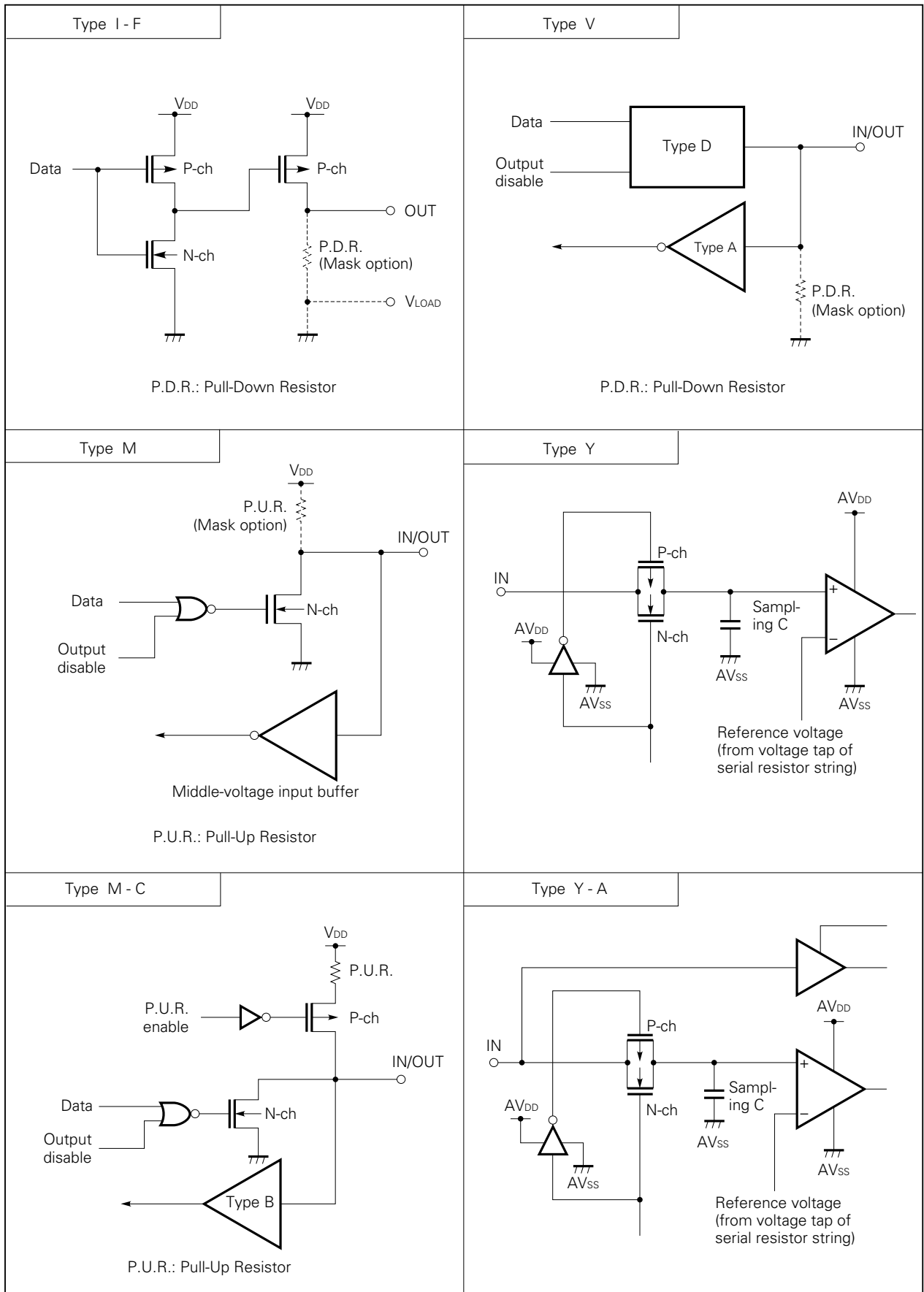

1.3 PIN INPUT/OUTPUT CIRCUITS (4/4)

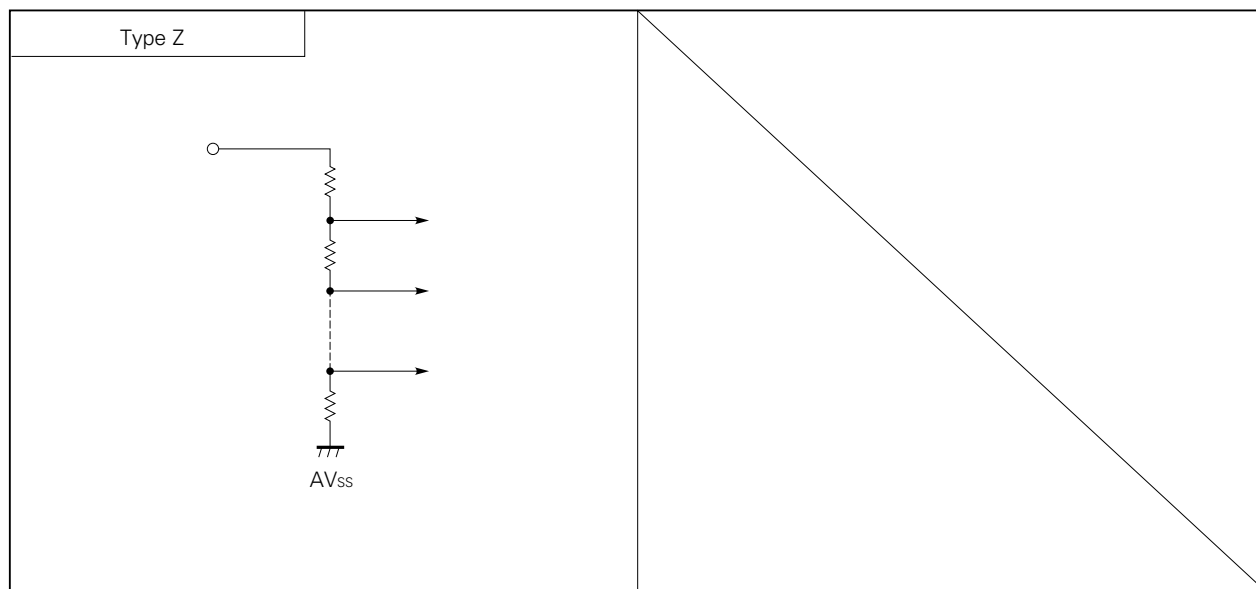

1.4 CONNECTION OF UNUSED μPD75238 PINS

Pin name	Recommended connection
P00/INT4	To be connected to V _{SS}
P01/SCK0	To be connected to V _{SS} or V _{DD}
P02/SO0/SB0	
P03/SI1/SB1	
P10/INT0-P12/INT2	
P13/TI0	To be connected to V _{SS}
P20/PTO0	Input state : To be connected to V _{SS} or V _{DD} Output state: To be left open
P21	
P22/PCL	
P23/BUZ	
P30-P33	
P40-P43	
P50-P53	
P60-P63	
P70-P73	
P80/PPO	
P81/SCK1	
P82/SO1	
P83/SI1	
P90/AN4-P93/AN7	
P100/S16-P103/S19	To be left open
P110/S20-P113/S23	
P120-P123	
P130-P133	
P140-P143	
P150-P153	
AN0-AN3	To be connected to V _{SS}
AV _{REF}	
AV _{DD}	To be connected to V _{DD}
AV _{SS}	To be connected to V _{SS}
XT1	To be connected to V _{SS} or V _{DD}
XT2	To be left open
V _{LOAD}	To be connected to V _{SS}

2. ARCHITECTURE AND MEMORY MAP OF THE μPD75238

The μPD75238 has three architectural features:

- (a) Data memory bank configuration
- (b) General register bank configuration
- (c) Memory-mapped I/O

Each of these features is explained below.

2.1 DATA MEMORY BANK CONFIGURATION AND ADDRESSING MODES











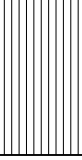

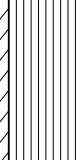

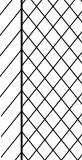









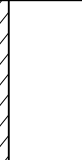



As shown in Fig. 2-1, the data memory space of the μPD75238 contains a static RAM (928 words × 4 bits) at addresses 000H to 19FH and 200H to 3FFH, a display data memory (96 words × 4 bits) at addresses 1A0H to 1FFH, and peripheral hardware (such as I/O ports and timers) at addresses F80H to FFFH. To address a 12-bit address in this data memory space, the μPD75238 uses such a memory bank configuration that the low-order eight bits are specified with an instruction directly or indirectly, and the high-order four bits are used to specify a memory bank (MB).

To specify a memory bank (MB), a memory bank enable flag (MBE) and memory bank select register (MBS) are contained, allowing the addressing indicated in Fig. 2-1 and Table 2-1. (The MBS is a register used to select a memory bank, and can be set to 0, 1, 2, 3, or 15. The MBE is a flag used to determine whether a memory bank selected using the MBS register is to be enabled. The MBE is automatically saved or restored at the time of interrupt processing or subroutine processing, so that it can be freely set in interrupt processing and subroutine processing.)

In addressing data memory space, the MBE is usually set to 1 (MBE = 1), and the static RAM in the memory bank specified by the MBS is operated. However, the MBE = 0 mode or the MBE = 1 mode can be selected for each step of program processing for more efficient programming.

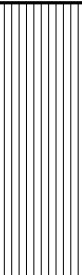
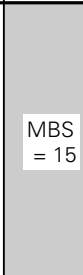
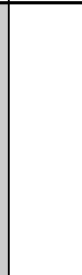
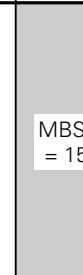
	Applicable program processing
MBE = 0 mode	<ul style="list-style-type: none"> • Interrupt processing • Processing that repeats internal hardware and static RAM operations • Subroutine processing
MBE = 1 mode	<ul style="list-style-type: none"> • Usual program processing

Fig. 2-1 Data Memory Organization and Addressing Range of Each Addressing Mode

Addressing mode	mem mem.bit		@HL @H + mem.bit		@DE @DL	Stack addressing	fmem.bit	pmem.@L
	MBE = 0	MBE = 1	MBE = 0	MBE = 1	-	-	-	-
000H								
01FH								
020H								
07FH								
0FFH								
100H								
19FH								
1A0H								
1FFH								
200H								
2FFH								
300H								
3FFH								
Not contained								
F80H								
FC0H								
FFFH								
Peripheral hardware area (memory bank 15)								
FFFH								
FFFH								

Remark — : Don't care

Table 2-1 Addressing Modes

Addressing mode	Representation format	Specified address
1-bit direct addressing	mem.bit	Bit specified by bit at the address specified by MB and mem. In this case: When MBE = 0 and mem = 00H-7FH, MB = 0 When MBE = 0 and mem = 80H-FFH, MB = 15 When MBE = 1, MB = MBS
4-bit direct addressing	mem	Address specified by MB and mem. In this case: When MBE = 0 and mem = 00H-7FH, MB = 0 When MBE = 0 and mem = 80H-FFH, MB = 15 When MBE = 1, MB = MBS
8-bit direct addressing		Address specified by MB and mem (mem: even address). In this case: When MBE = 0 and mem = 00H-7FH, MB = 0 When MBE = 0 and mem = 80H-FFH, MB = 15 When MBE = 1, MB = MBS
4-bit register indirect addressing	@HL	Address specified by MB and HL. In this case, MB = MBE• MBS
	@HL+ @HL-	Address specified by MB and HL. In this case, MB = MBE• MBS. HL+ automatically increments the L register after addressing. HL- automatically decrements the L register after addressing.
	@DE	Address specified by DE in memory bank 0
	@DL	Address specified by DL in memory bank 0
8-bit register indirect addressing	@HL	Address specified by MB and HL. In this case, MB = MBE• MBS. Bit 0 of the L register is ignored.
Bit manipulation addressing	fmem.bit	Bit specified by bit at the address specified by fmem. In this case: fmem = FB0H-FBFH (interrupt-related hardware) fmem = FF0H-FFFH (I/O port)
	pmem.@L	Bit specified by the low-order 2 bits of the L register at the address specified by the high-order 10 bits of pmem and the high-order 2 bits of the L register. In this case, pmem = FC0H-FFFH
	@H+mem.bit	Bit specified by bit at the address specified by MB, H, and the low-order 4 bits of mem. In this case, MB = MBE• MBS
Stack addressing	-	Address specified by SP in memory bank 0, 1, 2, and 3 selected by SBS

As summarized in Table 2-1, the μPD75238 allows both direct and indirect addressing in data memory manipulation for 1-bit data, 4-bit data, and 8-bit data, so that very efficient and simple programming can be performed.

2.2 GENERAL REGISTER BANK CONFIGURATION

The μPD75238 contains four register banks, each consisting of eight general registers: X, A, B, C, D, E, H, and L. These registers are mapped to addresses 00H to 1FH in memory bank 0 of the data memory. (See Fig. 2-2.) To specify a general register bank, a register bank enable flag (RBE) and a register bank select register (RBS) are contained. The RBS is a register used to select a register bank, and the RBE is a flag used to determine whether a register bank selected using the RBS is to be enabled. The register bank (RB) enabled at instruction execution is determined as $RB = RBE \cdot RBS$

As indicated in Table 2-2, the μPD75238 enables the user to create programs in a very efficient manner by selecting a register bank from the four register banks, depending on whether the processing is normal processing or interrupt processing. (The RBE is automatically saved and set at the time of interrupt processing, and is automatically restored upon completion of interrupt processing.)

Table 2-2 Recommended Use of Register Banks with Normal Routines and Interrupt Routines

Normal processing	Use register banks 2 and 3 with RBE = 1.
Single interrupt processing	Use register bank 0 with RBE = 0.
Dual interrupt processing	Use register bank 1 with RBE = 1. (In this case, the RBS needs to be saved and restored.)
Multiple (triple or more) interrupt processing	Save and restore the registers with PUSH or POP.

The general registers allow transfers, comparisons, arithmetic/logical operations, and increments and decrements not only on a 4-bit basis, but also on an 8-bit basis with the XA, HL, DE, and BC register pairs. In this case, the register pairs of the register bank that has the inverted value of bit 0 of a register bank specified by $RBE \cdot RBS$ can be specified as XA', HL', DE', and BC', thus providing eight 8-bit registers. (See Fig. 2-3.)

Fig. 2-2 General Register Configuration (4-Bit Processing)

X	01H	A	00H	Register bank 0 (RBE•RBS = 0)
H	03H	L	02H	
D	05H	E	04H	
B	07H	C	06H	
X	09H	A	08H	Register bank 1 (RBE•RBS = 1)
H	0BH	L	0AH	
D	0DH	E	0CH	
B	0FH	C	0EH	
X	11H	A	10H	Register bank 2 (RBE•RBS = 2)
H	13H	L	12H	
D	15H	E	14H	
B	17H	C	16H	
X	19H	A	18H	Register bank 3 (RBE•RBS = 3)
H	1BH	L	1AH	
D	1DH	E	1CH	
B	1FH	C	1EH	

Fig. 2-3 General Register Configuration (8-Bit Processing)

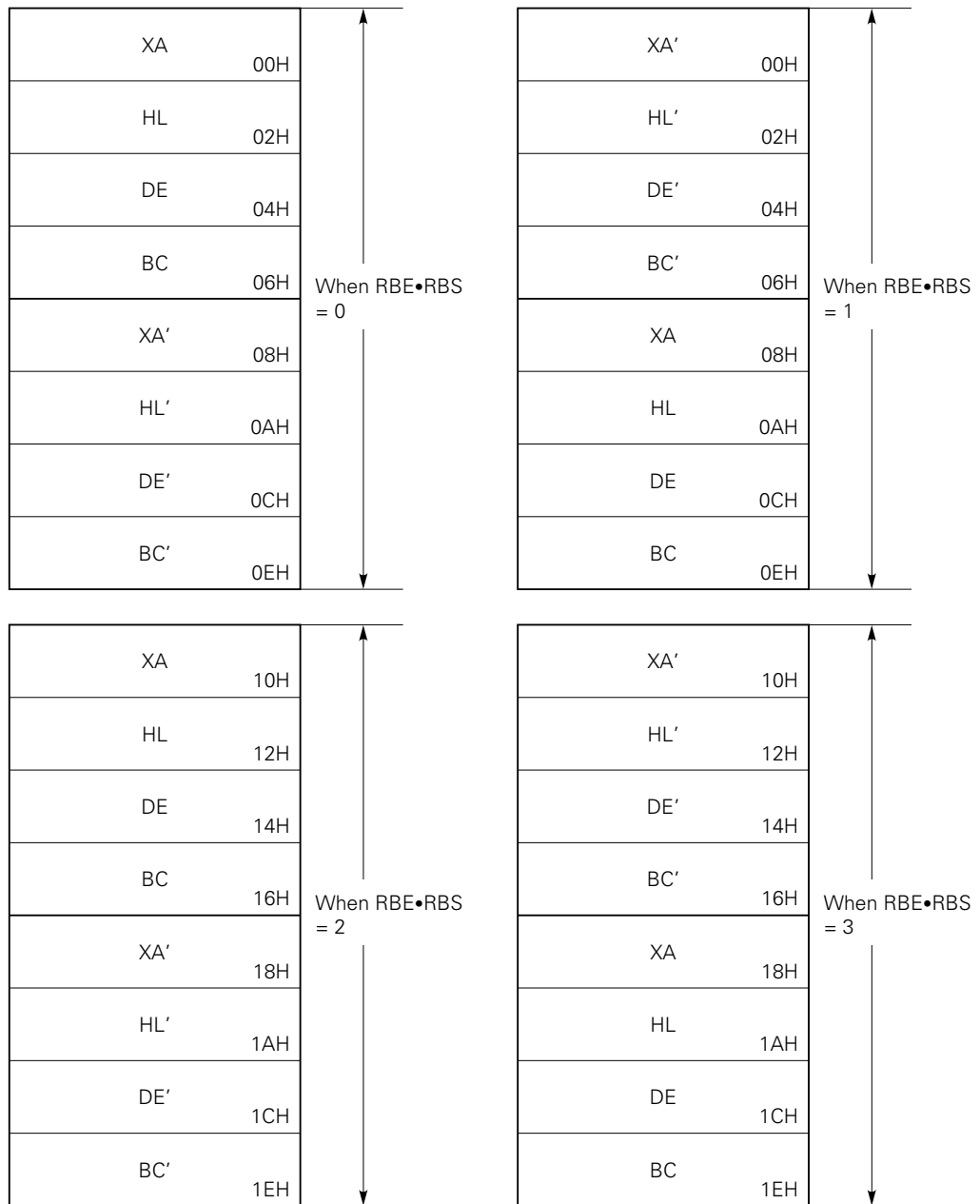

2.3 MEMORY-MAPPED I/O

The μPD75238 employs memory-mapped I/O, which maps peripheral hardware such as timers and I/O ports to addresses F80H to FFFH in the data memory space as shown in Fig. 2-1. This means that there is no particular instruction to control peripheral hardware, but all peripheral hardware is controlled using memory manipulation instructions. (Some mnemonics for hardware control are available to make programs readable.)

To manipulate peripheral hardware, the addressing modes listed in Table 2-3 can be used.

The display data memory, key scan registers, and port H mapped to addresses 1A0H to 1FFH are to be manipulated by specifying memory bank 1.

Table 2-3 Addressing Modes Applicable to Peripheral Hardware Mapped to Addresses F80H to FFFH

	Applicable addressing mode	Applicable hardware
Bit manipulation	Direct addressing mode specifying mem.bit with MBE = 0 or (MBE = 1, MBS = 15)	All hardware allowing bit manipulation
	Direct addressing mode specifying fmem.bit regardless of MBE and MBS setting	IST0, IST1, MBE, RBE, IExxx, IRQxxx, PORTn.0-3
	Indirect addressing mode specifying pmem.@L regardless of MBE and MBS setting	PORTn.
4-bit manipulation	Direct addressing mode specifying mem with MBE = 0 or (MBE = 1, MBS = 15)	All hardware allowing 4-bit manipulation
	Register indirect addressing mode specifying @HL with (MBE = 1, MBS = 15)	
8-bit manipulation	Direct addressing mode specifying mem (even address) with MBE = 0 or (MBE = 1, MBS = 15)	All hardware allowing 8-bit manipulation addressing
	Register indirect addressing mode specifying @HL (with the L register containing an even number) with (MBE = 1, MBS = 15)	

Table 2-4 summarizes the I/O map of the μPD75238.

The items in Table 2-4 have the following meanings:

- Symbol: Name representing the address of incorporated hardware, which can be coded in the operand field of an instruction
- R/W : Indicates whether the hardware allows read/write operation.
 R/W: Both read and write operations possible
 R : Read only
 W : Write only
- Number of manipulatable bits:
 Indicates the number of bits that can be processed in hardware manipulation
- Bit manipulation addressing:
 Bit manipulation addressing applicable in hardware bit manipulation

Table 2-4 μPD75238 I/O Map (1/4)

Address	Hardware name (symbol)				R/W	Number of manipulatable bits			Bit manipulation addressing	Remarks
	b3	b2	b1	b0		1 bit	4 bits	8 bits		
F80H	Stack pointer (SP)				R/W	-	-	○		Bit 0 is always set to 0.
F82H	Resister bank select register (RBS)				R>Note 1	-	○	○		Note 2
F83H	Memory bank select register (MBS)					-	○			
F84H	Stack bank select register (SBS)				R/W	-	○	-		Bits 2 and 3 are always set to 0.
F85H	Basic interval timer mode register (BTM)				W	Δ	○	-	mem.bit	Only bit 3 allows bit manipulation.
F86H	Basic interval timer (BT)				R	-	-	○		
F88H	Display mode register (DSPM)				W	-	○	-		
F89H	Dimmer select register (DIMS)				W	-	○	-		
F8AH	KSF	Digit select register (DIGS)			R/W	Δ	○	-	mem.bit	Only bit 3 allows a bit test.
F90H	Timer pulse generator mode register (TPGM)				W	Δ	Δ	○	mem.bit	Only bit 3 allows bit manipulation.
F94H	Timer pulse generator modulo register L (MODL)				R/W	-	-	○		
F96H	Timer pulse generator modulo register H (MODH)				R/W	-	-	○		
F98H	Clock mode register (WM)				W	-	-	○		
FA0H	Timer/event counter 0 mode register (TM0)				W	Δ	-	○		Only bit 3 allows bit manipulation.
FA2H	TOE0				W	○	-	-		
FA4H	Timer/event counter 0 count register (T0)				R	-	-	○		
FA6H	Timer/event counter 0 modulo register (TMOD0)				W	-	-	○		
FA8H	Event counter mode register (TM1)				W	Δ	-	○		Only bit 3 allows bit manipulation.
FABH	Gate control register (GATEC)				W	-	○	-		
FACH	Count register (T1)				R	-	-	○		

- Notes 1.** For the SEL instruction, these registers are both readable and writable.
2. Can be operated separately as the RBS and MBS during 4-bit manipulation.
 Can also be operated as the BS during 8-bit manipulation.

★

Table 2-4 μPD75238 I/O Map (2/4)

Address	Hardware name (symbol)				R/W	Number of manipulatable bits			Bit manipulation addressing	Remarks
	b3	b2	b1	b0		1 bit	4 bits	8 bits		
FB0H	IST1	IST0	MBE	RBE	R/W	○	○	○	fmem.bit	
	Program status word (PSW)					-	-			
★ FB2H	Interrupt priority select register (IPS)				W	○	○	-		
FB3H	Processor clock control register (PCC)				W	○	○			
FB4H	INT0 mode register (IM0)				W	-	○	-		Bit 2 is always set to 0.
FB5H	INT1 mode register (IM1)				W	-	○			Bits 1, 2, and 3 are always set to 0.
★ FB7H	System clock control register (SCC)				W	○	-	-		Only bits 0 and 3 allow bit manipulation.
FB8H	IE4	IRQ4	IEBT	IRQBT	R/W	○	○	-	fmem.bit	
FB9H	/	/	/	EOT	R/W	○	○			
FBAH	/	/	IEW	IRQW	R/W	○	○	-		
FBBH	IEKS	IRQKS	IETPG	IRQTPG	R/W	○	○			
FBCH	/	IRQT1	IET0	IRQT0	R/W	○	○	-		
FBDH	/	/	IECSI0	IRQCSI0	R/W	○	○			
FBEH	IE1	IRQ1	IE0	IRQ0	R/W	○	○	-		
FBFH	/	/	IE2	IRQ2	R/W	○	○			
FC0H	Bit sequential buffer 0 (BSB0)				R/W	○	○	○		
FC1H	Bit sequential buffer 1 (BSB1)				R/W	○	○			
FC2H	Bit sequential buffer 2 (BSB2)				R/W	○	○	○		
FC3H	Bit sequential buffer 3 (BSB3)				R/W	○	○			
FC8H	/	/	CSIM11	CSIM10	W	-	-	○		
★ FC9H	CSIE1	/	/	/	W	○	-			
FCCH	Serial I/O shift register 1 (SIO1)				R/W	-	-	○		

Table 2-4 μPD75238 I/O Map (3/4)

Address	Hardware name (symbol)				R/W	Number of manipulatable bits			Bit manipulation addressing	Remarks
	b3	b2	b1	b0		1 bit	4 bits	8 bits		
FD0H	Clock output mode register (CLOM)				W	-	○	-		
FD4H	Static mode register B (STATB)				W	-	-	○		
FD6H	Static mode register A (STATA)				W	-	-	○		
FD8H	SOC	EOC			R/W	Δ	-	○		ADM is write only during 8-bit manipulation. ★
	A/D conversion mode register (ADM)					-	-			
FDAH	SA register (SA)				R	-	-	○		
FDCH	Pull-up resistor specification register group A (POGA)				W	-	-	○		
FE0H	Serial operation mode register (CSIM0)				W	-	-	○	mem.bit	CSIM0 is write only during 8-bit manipulation.
	CSIE0	COI	WUP		R/W	○	○			
FE2H	CMDD	RELD	CMDT	RELT	R/W	○	-	-	mem.bit	
	SBI control register (SBIC)									
	BSYE	ACKD	ACKE	ACKT						
FE4H	Serial I/O shift register 0 (SIO0)				R/W	-	-	○		
FE6H	Slave address register (SVA)				W	-	-	○		
FE8H	PM33	PM32	PM31	PM30	W	-	-	○		
	Port mode register group A (PMGA)									
	PM63	PM62	PM61	PM60						
FECH	-	PM2	-	-	W	-	-	○		
	Port mode register group B (PMGB)									
	PM7	-	PM5	PM4						

Table 2-4 μPD75238 I/O Map (4/4)

Address	Hardware name (symbol)				R/W	Number of manipulatable bits			Bit manipulation addressing	Remarks
	b3	b2	b1	b0		1 bit	4 bits	8 bits		
FF0H	Port 0 (PORT0)				R	○	○	-	fmem.bit pmem.@L	
FF1H	Port 1 (PORT1)				R	○	○			
FF2H	Port 2 (PORT2)				R/W	○	○	-		
FF3H	Port 3 (PORT3)				R/W	○	○			
FF4H	Port 4 (PORT4)				R/W	○	○	○		
FF5H	Port 5 (PORT5)				R/W	○	○			
FF6H	Port 6 (PORT6)				R/W	○	○	○		
FF7H	Port 7 (PORT7)				R/W	○	○			
FF8H	Port 8 (PORT8)				R	○	○	-		
FF9H	Port 9 (PORT9)				R	○	○			
FFAH	Port 10 (PORT10)				W	○	○	○		
FFBH	Port 11 (PORT11)				W	○	○			
FFCH	Port 12 (PORT12)				W	○	○	○		
FFDH	Port 13 (PORT13)				W	○	○			
FFEH	Port 14 (PORT14)				W	○	○	○		
FFFH	Port 15 (PORT15)				W	○	○			
1A0H+4n	Display data memory: S16-S23 (n = 0 to 15)				R/W	○	○	○	mem.bit	
1A1H+4n					R/W	○	○			
1BEH	Key scan register (KS2)				R/W	○	○	○		
1BFH					R/W	○	○			
1C0H+4n	Display data memory: S0-S7 (n = 0 to 15)				R/W	○	○	○		
1C1H+4n					R/W	○	○			
1C2H+4n	Display data memory: S8-S15 (n = 0 to 15)				R/W	○	○	○		
1C3H+4n					R/W	○	○			
1FCH	Key scan register (KS0)				R/W	○	○	○		
1FDH					R/W	○	○			
1FEH	Key scan register (KS1)				R/W	○	○	○		
1FFH	Port H (PORTH)				R/W	○	○	○		

3. INTERNAL CPU FUNCTIONS

3.1 PROGRAM COUNTER (PC): 15 BITS

The program counter is a 15-bit binary counter for holding program memory address information.

Fig. 3-1 Program Counter Format

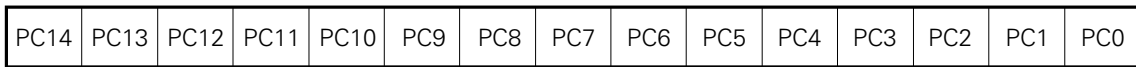

Note that the reset start address must be set within a space of 16K bytes (0000H to 3FFFH). This is because a $\overline{\text{RESET}}$ input sets the low-order six bits of program memory address 0000H in PC13 to PC8, and the contents of address 0001H in PC7 to PC0 for initialization.

3.2 PROGRAM MEMORY (ROM): 32640 WORDS × 8 BITS

The program memory is a mask-programmable ROM with a configuration of 32640 words×8 bits for storing programs, table data, and so forth.

Program memory is addressed by the program counter. Table data can be referenced using the table reference instruction (MOVT).

Fig. 3-2 shows the allowable branch address ranges for the branch instructions and subroutine call instructions. The whole-space branch instruction (BRA !addr1) and the whole-space call instruction (CALLA !addr1) allow a direct branch throughout the whole space 0000H to 7F7FH. The relative branch instruction (BR \$addr) allows a branch to addresses (PC - 15 to PC - 1 and PC + 2 to PC + 16) regardless of block boundaries.

The program memory is located at addresses 0000H to 7F7FH containing the following specially assigned addresses. (All areas excluding 0000H and 0001H can be used as normal program memory.)

- 0000H to 0001H
Vector table for holding the RBE and MBE setting values and program start address at the time of a $\overline{\text{RESET}}$ input. A reset start can be performed at an arbitrary address within a 16K-byte space (0000H to 3FFFH).
- 0002H to 000FH
Vector address table for holding the RBE and MBE setting values and program start address at the time of each vectored interrupt occurrence. Interrupt processing can be started at an arbitrary address within a 16K-byte space (0000H to 3FFFH).
- 0020H to 007FH
Table area referenced by the GETI instruction **Note**

Note The GETI instruction can represent an arbitrary 2-byte or 3-byte instruction or two 1-byte instructions in 1 byte, thus reducing the number of program bytes. (See **Section 8.1.**)

Fig. 3-2 Program Memory Map

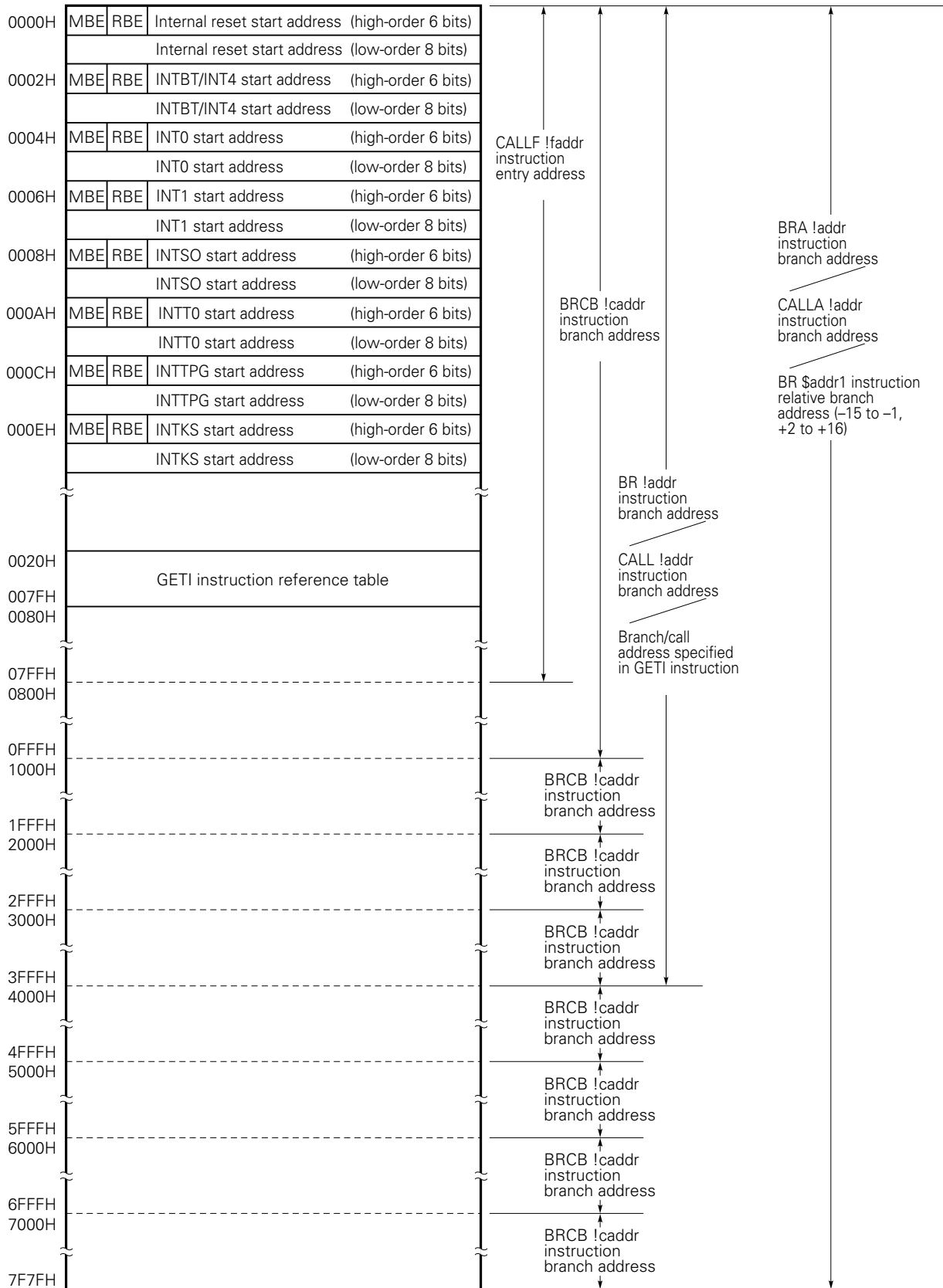

Caution The start address of an interrupt vector shown above consists of 14 bits. So, the start address must be set within a 16K-byte space (0000H to 3FFFH).

Remark In addition to the above, the BR PCDE and BR PCXA instructions can cause a branch to an address with only the low-order 8 bits of the PC changed.

3.3 DATA MEMORY (RAM)

The data memory consists of a static RAM and peripheral hardware.

The static RAM consists of an area of 768 words × 4 bits in memory banks 0, 2, and 3, an area of 160 words × 4 bits in memory bank 1, and an area of 96 words × 4 bits in memory bank 1, which is used also as display data memory. The RAM is used for storing processing data, and is also used as stack memory for subroutine and interrupt execution.

To particular memory addresses, general registers, display data memory, and peripheral hardware (various registers) are mapped. Data in these areas are manipulated using general register manipulation instructions and memory manipulation instructions (See Fig. 2-1).

As a stack area, all addresses in memory banks 0, 1, 2, and 3 (000H to 3FFH) can be used.

The data memory has a configuration of 4 bits per address, but allows 8-bit memory manipulation instructions to be used for 8-bit oriented manipulation, and also allows bit manipulation instructions to be used for bit-by-bit manipulation. Even addresses are to be specified for 8-bit manipulation instructions.

Fig. 3-4 shows the organization of the display data memory area (1A0H to 1FFH).

Fig. 3-3 Data Memory Map

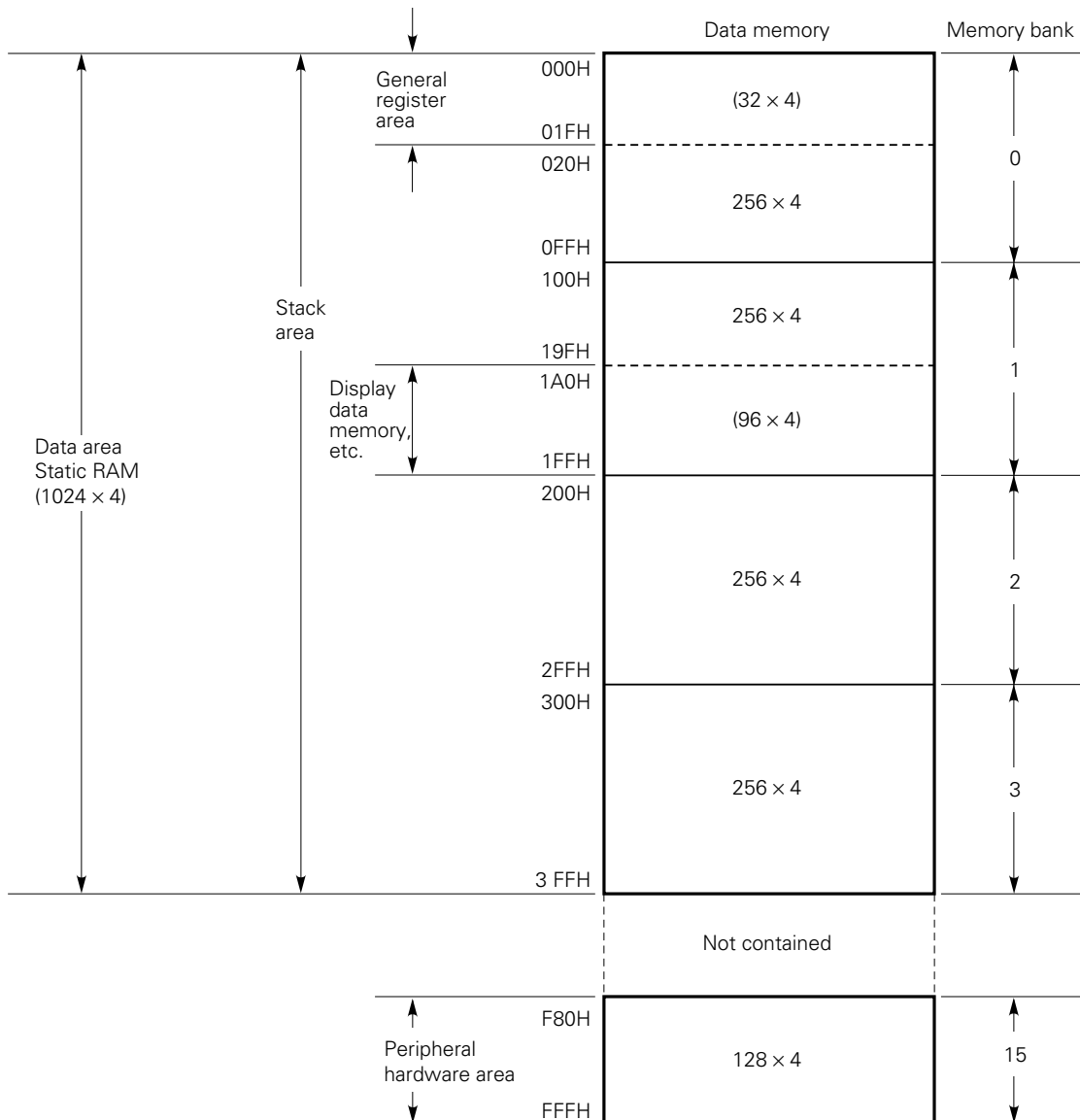

Fig. 3-4 Display Data Memory Configuration

		1 A 1 H	1 A 0 H	1 C 3 H	1 C 2 H	1 C 1 H	1 C 0 H
		1 A 3 H	1 A 2 H	1 C 7 H	1 C 6 H	1 C 5 H	1 C 4 H
		1 A 5 H	1 A 4 H	1 C B H	1 C A H	1 C 9 H	1 C 8 H
		1 A 7 H	1 A 6 H	1 C F H	1 C E H	1 C D H	1 C C H
		1 A 9 H	1 A 8 H	1 D 3 H	1 D 2 H	1 D 1 H	1 D 0 H
		1 A B H	1 A A H	1 D 7 H	1 D 6 H	1 D 5 H	1 D 4 H
		1 A D H	1 A C H	1 D B H	1 D A H	1 D 9 H	1 D 8 H
		1 A F H	1 A E H	1 D F H	1 D E H	1 D D H	1 D C H
		1 B 1 H	1 B 0 H	1 E 3 H	1 E 2 H	1 E 1 H	1 E 0 H
		1 B 3 H	1 B 2 H	1 E 7 H	1 E 6 H	1 E 5 H	1 E 4 H
		1 B 5 H	1 B 4 H	1 E B H	1 E A H	1 E 9 H	1 E 8 H
		1 B 7 H	1 B 6 H	1 E F H	1 E E H	1 E D H	1 E C H
		1 B 9 H	1 B 8 H	1 F 3 H	1 F 2 H	1 F 1 H	1 F 0 H
		1 B B H	1 B A H	1 F 7 H	1 F 6 H	1 F 5 H	1 F 4 H
		1 B D H	1 B C H	1 F B H	1 F A H	1 F 9 H	1 F 8 H
		1 B F H	1 B E H(KS2)	1 F F H(PORTH)	1 F E H(KS1)	1 F D H	1 F C H(KS0)
Number of manipulatable bits	1 bit	○	○	○	○	○	○
	4 bits	○	○	○	○	○	○
	8 bits	○		○		○	

Remarks 1. KS0, KS1, and KS2 are key scan registers.

2. PORTH is the high-voltage, high-current output port, and is also used for digit output.

3.4 GENERAL REGISTERS: 8 × 4 BITS × 4 BANKS

The general registers are mapped to particular addresses in data memory. Four banks of registers are provided, with each bank consisting of eight 4-bit registers (B, C, D, E, H, L, X, A).

The register bank (RB) to be enabled at the time of instruction execution is determined by $RB = RBE \cdot RBS$: (RBS = 0 to 3)

Each general register allows 4-bit manipulation. In addition, BC, DE, HL, or XA serves as a register pair for 8-bit manipulation. DL also makes a register pair as well as DE and HL; these three register pairs can be used as data pointers.

A general register area can be addressed and accessed as normal RAM, regardless of whether it is used as a register.

Fig. 3-5 General Register Format

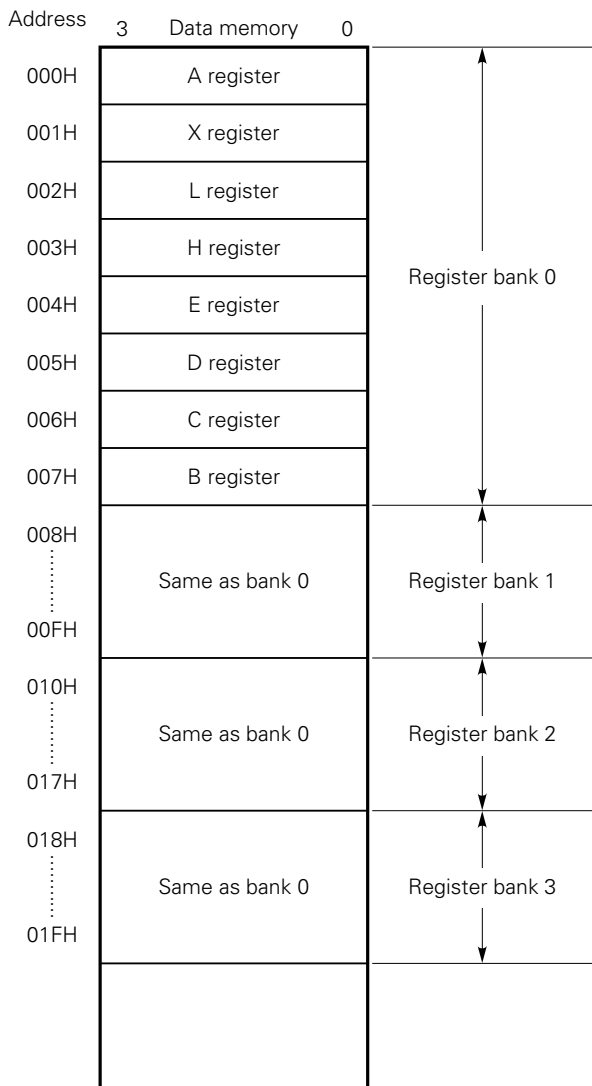
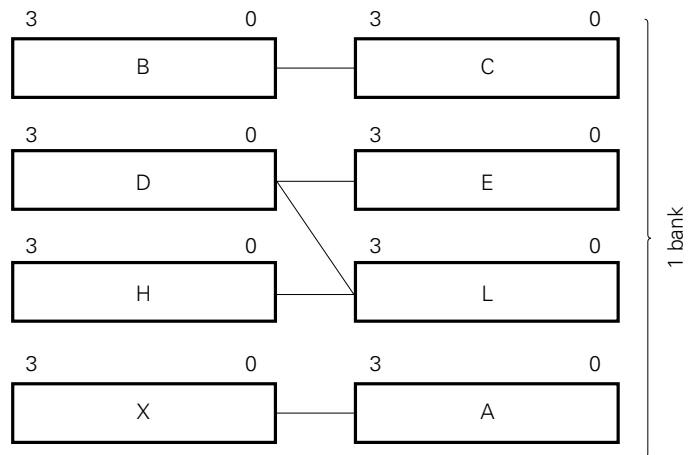

Fig. 3-6 Register Pair Format



3.5 ACCUMULATORS

In the μPD75238, the A register and the XA register pair function as accumulators. The A register is mainly used for 4-bit data processing instructions, and the XA register pair is mainly used for 8-bit data processing instructions.

For a bit manipulation instruction, the carry flag (CY) functions as a bit accumulator.

Fig. 3-7 Accumulators

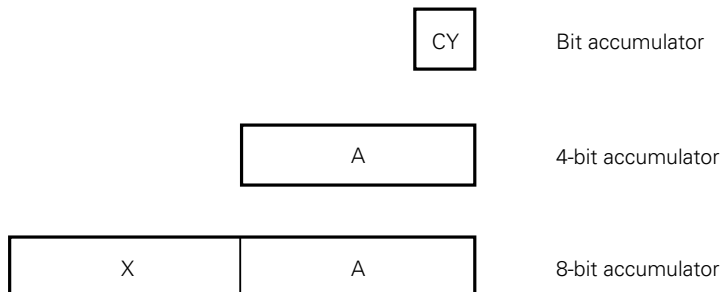

3.6 STACK POINTER (SP) AND STACK BANK SELECT REGISTER (SBS)

The μPD75238 uses static RAM as stack memory (LIFO scheme), and the 8-bit register holding the start address of the stack area is the stack pointer (SP).

The stack area is located at addresses 000H to 3FFH in memory banks 0, 1, 2, and 3. Either of the memory banks is selected according to the value of the 4-bit SBS.

The SP is decremented before a write (save) operation to stack memory, and is incremented after a read (restoration) operation from stack memory. The SBS is set with a 4-bit memory manipulation instruction. Note that the high-order two bits are always set to 00.

Fig. 3-9 and 3-10 show data saved to and restored from stack memory in these stack operations.

To place the stack area at a given location, the SP can be initialized with an 8-bit memory manipulation instruction, and the SBS can be initialized with a 4-bit memory manipulation instruction. Both can be read from as well.

Table 3-1 Stack Area to Be Selected by the SBS

SBS		Stack area
SBS1	SBS2	
0	0	Memory bank 0
0	1	Memory bank 1
1	0	Memory bank 2
1	1	Memory bank 3

When the SP is initialized to 00H, a stack operation starts at the high-order address (nFFH) of memory bank n: n = 0, 1, 2, or 3) specified with the SBS.

A stack area must be within the memory bank specified with the SBS. If a stack operation exceeds address n00H, the operation returns to address nFFH of the same bank. Stacking beyond memory bank boundaries is enabled only by resetting the SBS.

A RESET signal occurrence causes the contents of the SP and the SBS to be undefined, so that the SP must always be initialized to a desired value at the start of the program.

Fig. 3-8 Stack Bank Select Register Format

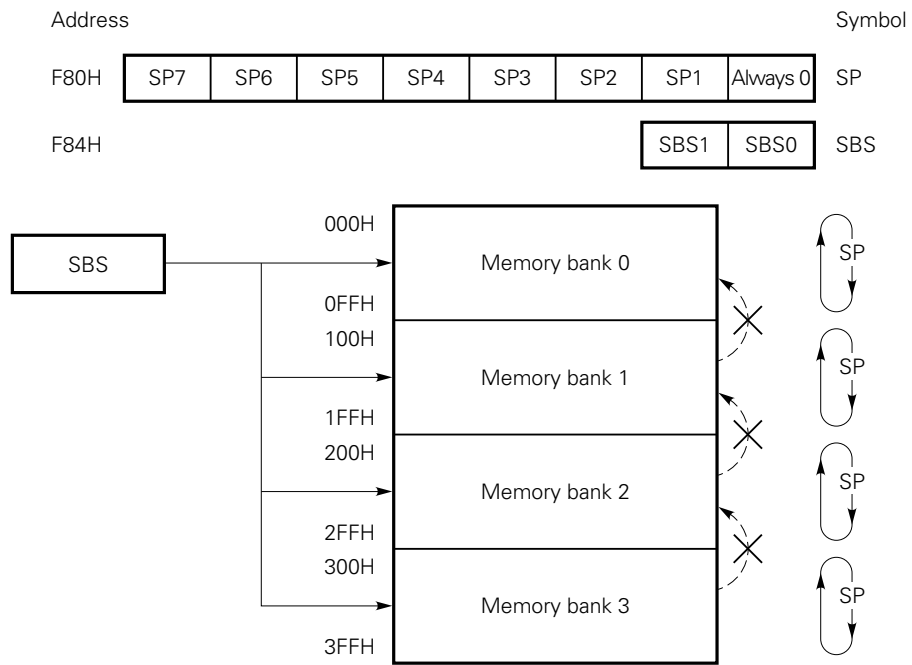

Fig. 3-9 Data Saved to Stack Memory

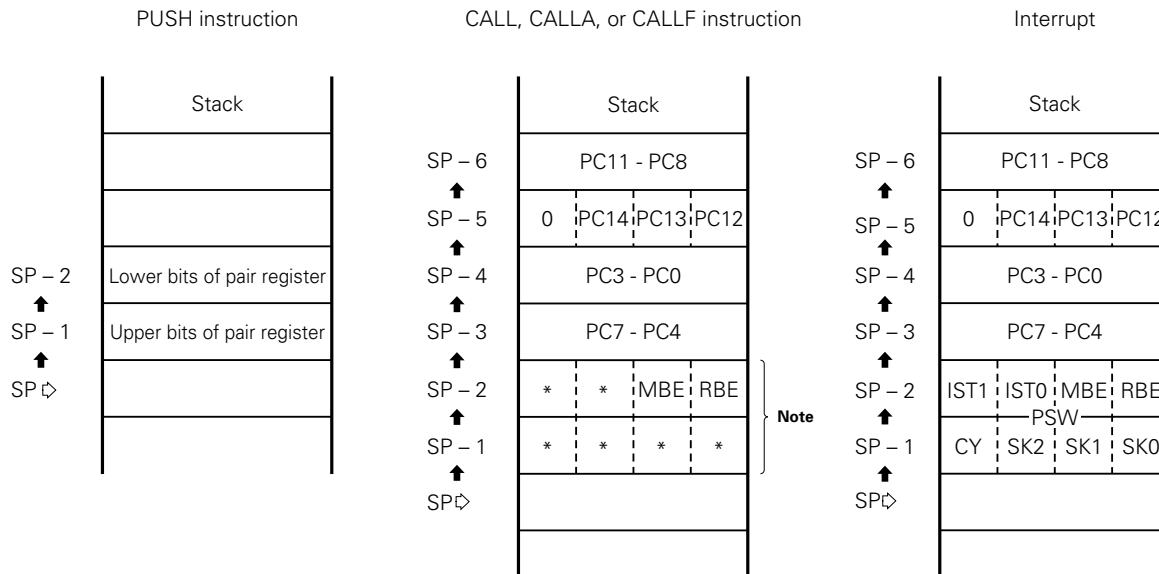
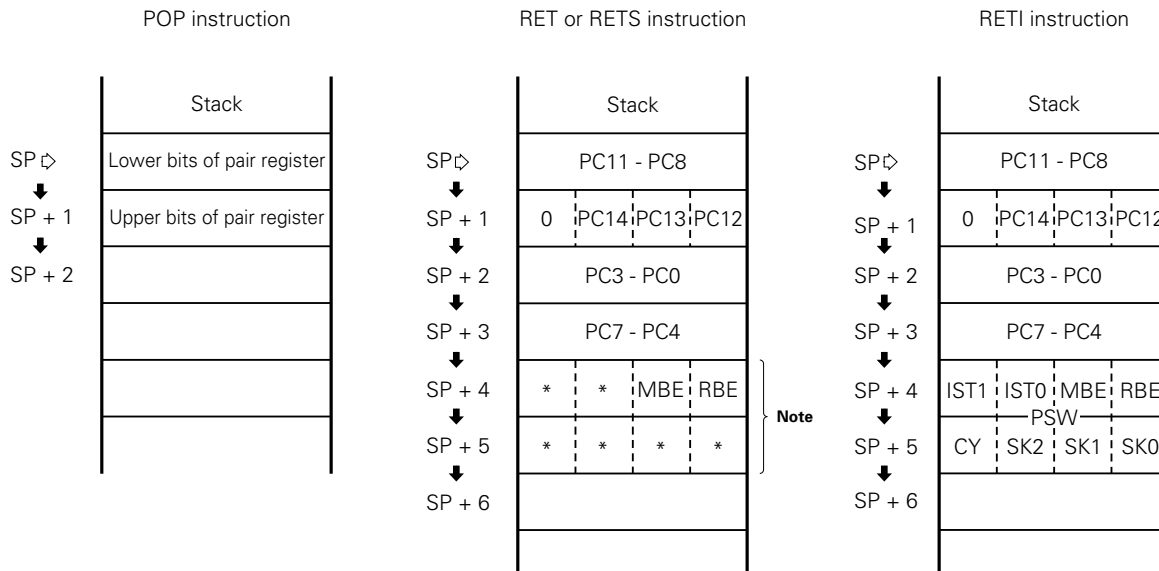

Fig. 3-10 Data Restored from Stack Memory



Note A PSW other than the MBE or RBE is not saved/restored.

Remark Data marked with * is undefined.

3.7 PROGRAM STATUS WORD (PSW): 8 BITS

The program status word (PSW) consists of various flags closely associated with processor operations.

The PSW is mapped to addresses FB0H and FB1H in the data memory space. The four bits at address FB0H can be manipulated with a memory manipulation instruction. Address FB1H cannot be manipulated with a normal data memory manipulation instruction.

Fig. 3-11 Program Status Word Format

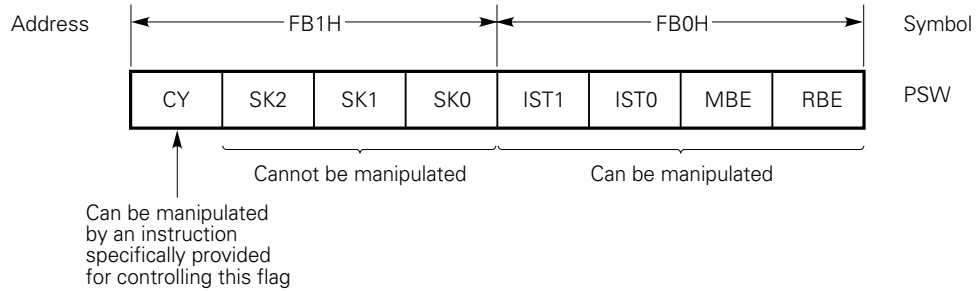

Table 3-2 PSW Flags Saved/Restored in Stack Operation

		Saved/restored flag
Save	When CALL, CALLA, or CALLF instruction is executed	MBE and RBE are saved.
	When hardware interrupt occurs	All PSW bits are saved.
Restore	When RET or RETS instruction is executed	MBE and RBE are restored.
	When RETI is executed	All PSW bits are restored.

(1) Carry flag (CY)

The carry flag is a 1-bit flag used to store overflow or underflow occurrence information when an arithmetic operation with a carry (ADDC, SUBC) is executed.

The carry flag also has the function of a bit accumulator, and therefore can be used to store the result of a Boolean operation performed on the CY and bit at a specified data memory bit address.

The carry flag is manipulated using special instructions, independently of the other PSW bits.

A $\overline{\text{RESET}}$ signal occurrence causes the carry flag to be undefined.

Table 3-3 Carry Flag Manipulation Instructions

	Instruction (mnemonic)	Carry flag operation/processing
Instruction dedicated to carry flag manipulation	SET1 CY CLR1 CY NOT1 CY SKT CY	Sets CY to 1. Clears CY to 0. Inverts the contents of CY. Skips if CY is set to 1.
Bit transfer instruction	MOV1 mem*.bit CY MOV1 CY,mem*.bit	Transfers the contents of CY to a specified bit. Transfers the contents of a specified bit to CY.
Bit Boolean instruction	AND1 CY,mem*.bit OR1 CY,mem*.bit XOR1 CY,mem*.bit	ANDs, ORs, or XORs CY with the contents of a specified bit, then sets the result in CY.
Interrupt handling	Interrupt execution	Saves CY and all other PSW bits to stack memory in parallel.
	RETI	Restores CY together with the other PSW bits from stack memory.

Remark mem*.bit represents the following three addressing modes:

- fmem.bit
- pmem.@L
- @H+mem.bit

(2) Skip flags (SK2, SK1, SK0)

The skip flags are used to store skip status, and are automatically set or reset when the CPU executes an instruction.

The user cannot directly manipulate these flags as operands.

(3) Interrupt status flag (IST1, IST0)

The interrupt status flag is a 2-bit flag used to store the status of processing being performed. (For detailed information, see **Table 5-3**.)

Table 3-4 Information Indicated by the Interrupt Status Flag

IST1	IST0	Status of processing being performed	Processing and interrupt control
0	0	Status 0	Normal program processing is being performed. Any interrupts are acceptable.
0	1	Status 1	A lower- or higher-priority interrupt is being serviced. Higher-priority interrupts are acceptable.
1	0	Status 2	A higher-priority interrupt is being serviced. No interrupts are acceptable.
1	1	—	Not to be set

The interrupt priority control circuit (see **Fig. 5-1**) checks this flag to control multiple interrupts. The contents of the IST1 and IST0 are saved as part of the PSW to stack memory if an interrupt is accepted, then are automatically set to a one-step higher status. The RETI instruction restores the contents present before an interrupt occurs.

The interrupt status flag can be manipulated using a memory manipulation instruction, and the status of processing being performed can be changed by program control.

Caution The user must always disable interrupts with the DI instruction before manipulating this flag, and must enable interrupts with the EI instruction after manipulating this flag.

(4) Memory bank enable flag (MBE)

The memory bank enable flag is a 1-bit flag used to specify the address information generation mode for the high-order four bits of a 12-bit data memory address.

When the MBE is set to 1, the data memory address space is expanded, allowing all data memory space to be addressed.

When the MBE is reset to 0, the data memory address space is fixed, regardless of MBS setting. (See **Fig. 2-1.**)

A $\overline{\text{RESET}}$ input automatically initializes the MBE by setting the MBE to the content of bit 7 at program memory address 0.

In vectored interrupt processing, the MBE is automatically set to the content of bit 7 in the vector address table for servicing the interrupt.

Usually, the MBE is set to 0 in interrupt processing, and static RAM in memory bank 0 is used.

(5) Register bank enable flag (RBE)

The register bank enable flag is a 1-bit flag used to determine whether to expand the general register bank configuration.

When the RBE is set to 1, a set of general registers can be selected from register banks 0 to 3, depending on the setting of the register bank select register (RBS).

When the RBE is reset to 0, register bank 0 is always selected as general registers, regardless of the setting of the RBS.

A $\overline{\text{RESET}}$ input automatically initializes the RBE by setting the RBE to the content of bit 6 at program memory address 0.

When a vectored interrupt occurs, the RBE is automatically set to the content of bit 6 in the vector address table for servicing the interrupt. Usually, the RBE is set to 0 in interrupt processing. Register bank 0 is used for 4-bit processing, and register banks 0 and 1 are used for 8-bit processing.

3.8 BANK SELECT REGISTER (BS)

The bank select register consists of a register bank select register (RBS) and memory bank select register (MBS), which specify a register bank and memory bank to be used, respectively.

The RBS and MBS are set using the SEL RBn instruction and SEL MBn instruction, respectively.

The contents of BS can be saved to or restored from a stack area eight bits at a time by using the PUSH BS/POP BS instruction.

Fig. 3-12 Bank Select Register Format

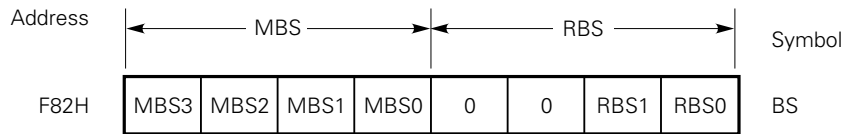

(1) Memory bank select register (MBS)

The memory bank select register is a 4-bit register used to store the high-order four bits of a 12-bit data memory address. The contents of this register specify a memory bank to be accessed. Memory banks 0, 1, 2, 3, and 15 can be specified.

The MBS is set with the SEL MBn instruction (n = 0, 1, 2, 3, 15)

Fig. 2-1 shows the range of addressing using MBE and MBS settings.

A RESET input initializes the MBS to 0.

(2) Register bank select register (RBS)

The register bank select register specifies a register bank to be used as general registers; a register bank can be selected from register banks 0 to 3.

The RBS is set with the SEL RBn instruction (n = 0 to 3).

A RESET input initializes the RBS to 0.

Table 3-5 Register Bank to Be Selected with the RBE and RBS

RBE	RBS				Register bank
	3	2	1	0	
0	0	0	×	×	Bank 0 is always selected.
1	0	0	0	0	Bank 0 is selected.
			0	1	Bank 1 is selected.
			1	0	Bank 2 is selected.
			1	1	Bank 3 is selected.

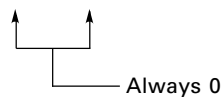

Remark ×: Don't care

4. PERIPHERAL HARDWARE FUNCTIONS

4.1 DIGITAL I/O PORTS

The μPD75238 employs memory-mapped I/O, enabling all I/O ports to be mapped to data memory space.

Fig. 4-1 Data Memory Address Assigned to Digital Port

Address	3	2	1	0	Symbol
FF0H	P03	P02	P01	P00	PORT 0
FF1H	P13	P12	P11	P10	PORT 1
FF2H	P23	P22	P21	P20	PORT 2
FF3H	P33	P32	P31	P30	PORT 3
FF4H	P43	P42	P41	P40	PORT 4
FF5H	P53	P52	P51	P50	PORT 5
FF6H	P63	P62	P61	P60	PORT 6
FF7H	P73	P72	P71	P70	PORT 7
FF8H	P83	P82	P81	P80	PORT 8
FF9H	P93	P92	P91	P90	PORT 9
FFAH	P103	P102	P101	P100	PORT 10
FFBH	P113	P112	P111	P110	PORT 11
FFCH	P123	P122	P121	P120	PORT 12
FFDH	P133	P132	P131	P130	PORT 13
FFEH	P143	P142	P141	P140	PORT 14
FFFH	P153	P152	P151	P150	PORT 15

(1) Configurations of digital I/O ports

Fig. 4-2 to Fig. 4-11 show the configurations of the ports.

(2) I/O mode setting

The I/O mode of each I/O port is set by the port mode register as shown in Fig. 4-12.

Each port functions as an input port when the corresponding bit of the port mode register is set to 0, and functions as an output port when the same corresponding bit is set to 1.

An 8-bit memory manipulation instruction is used to set port mode register group A or B.

A RESET input clears all bits of each port mode register to 0. This means that the output buffers are set off, and all ports are placed in the input mode.

(3) Operation of digital I/O ports

When an instruction is executed, the operation of the port and pins depends on the I/O mode setting, as listed in Table 4-1.

Table 4-1 I/O Port Operations by I/O Instructions

	Input mode (corresponding bit in the mode register is 0) [Output buffer is off]	Output mode (corresponding bit in the mode register is 1) [Output buffer is on]
When a 1-bit test instruction, 1-bit input instruction, or 4-/8-bit input instruction is executed	Receives data on certain pins.	Receives the contents of the output latch.
When a 4-/8-bit output instruction is executed	Transfers data in the accumulator to the output latch.	Outputs data in the accumulator to output pins.
When a 1-bit output instruction ^{Note} is executed	The contents of the output latch are undefined.	Changes the output pin state according to the instruction.

Note Instructions such as SET1/CLR1/MOV1 PORTn.bit, CY

Fig. 4-2 Configuration of Ports 0, 1, and 8

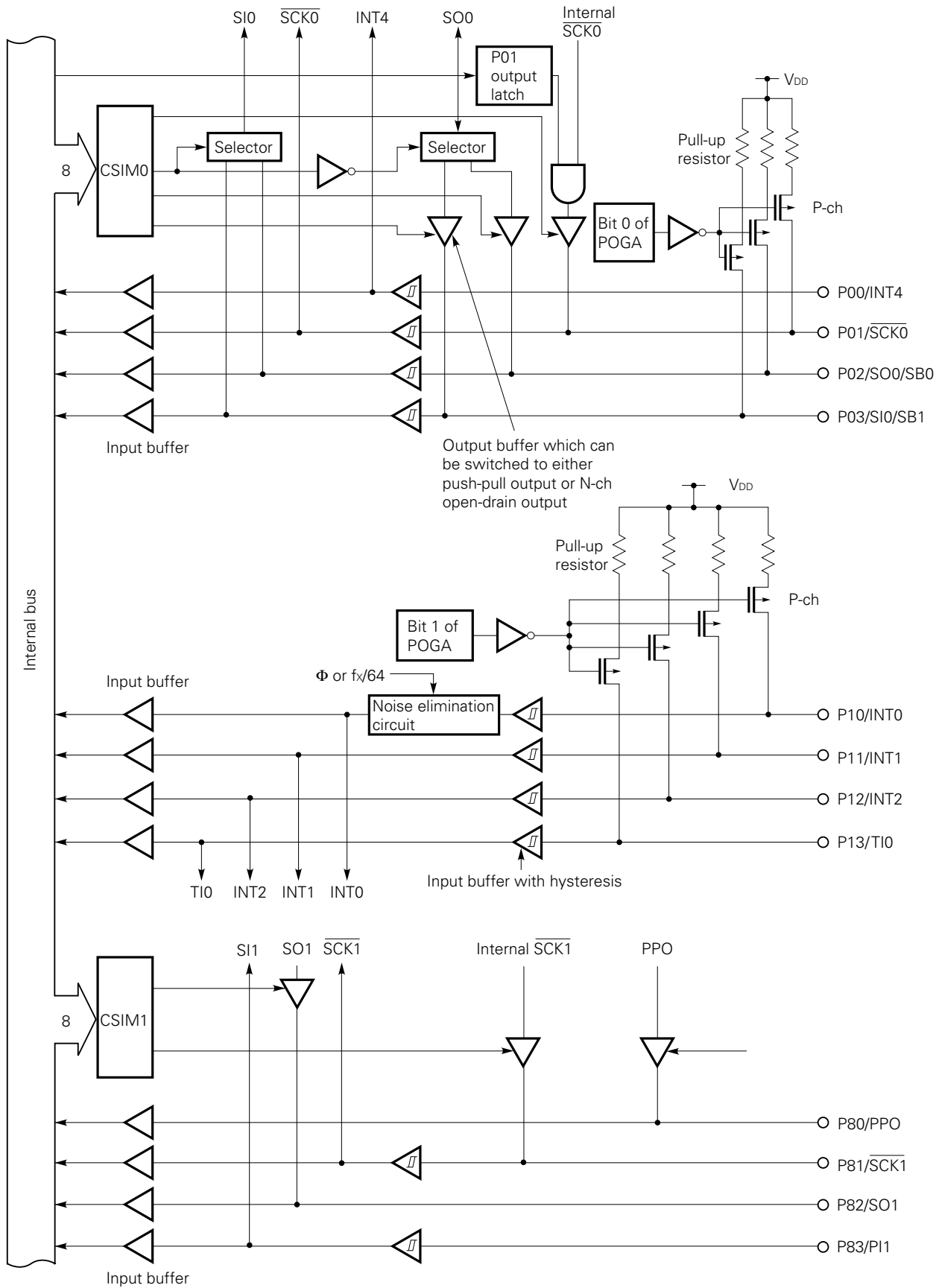

Fig. 4-3 Configuration of Ports 3n and 6n (n = 0 to 3)

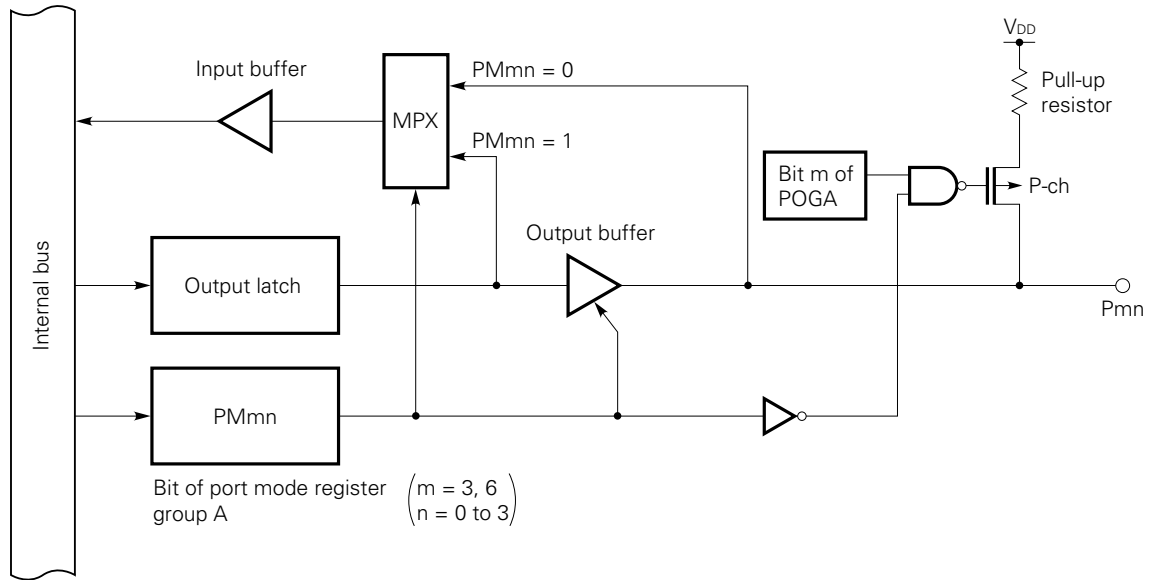

Fig. 4-4 Configuration of Port 2

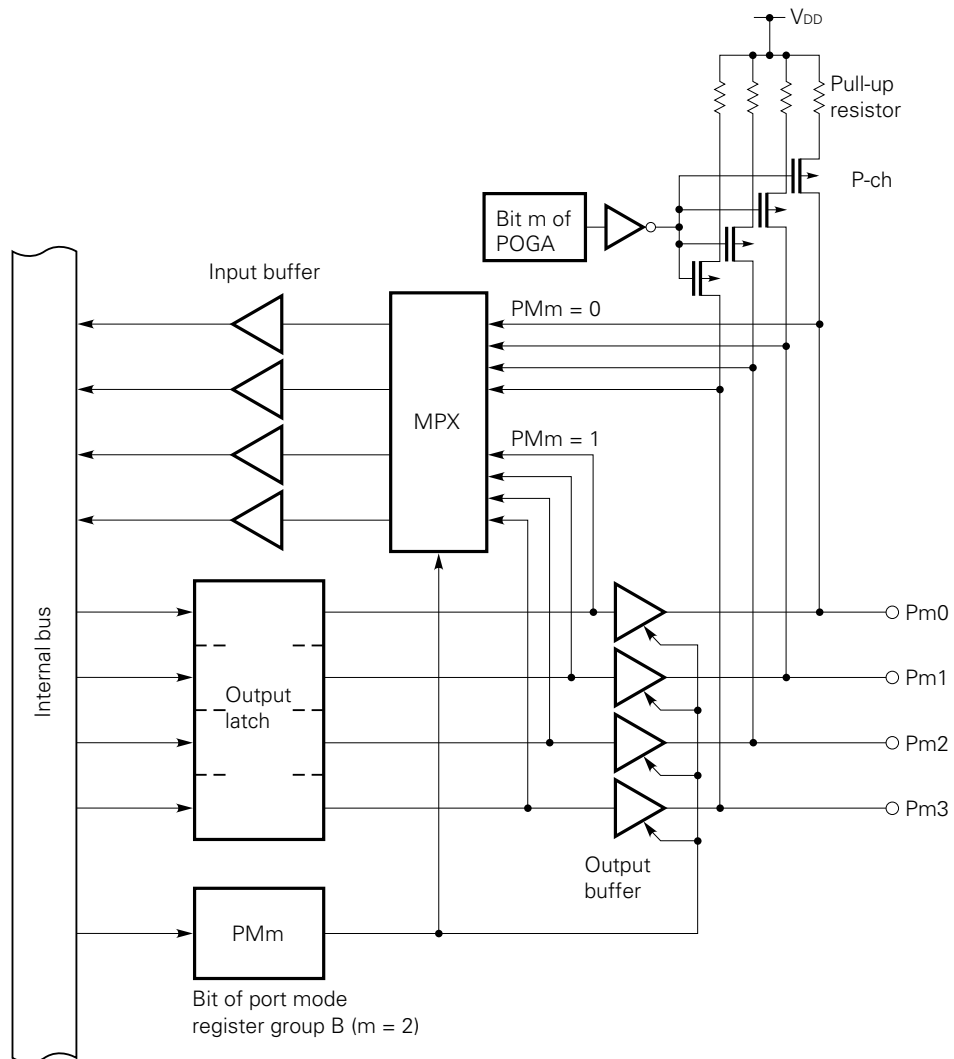

Fig. 4-5 Configuration of Ports 4 and 5

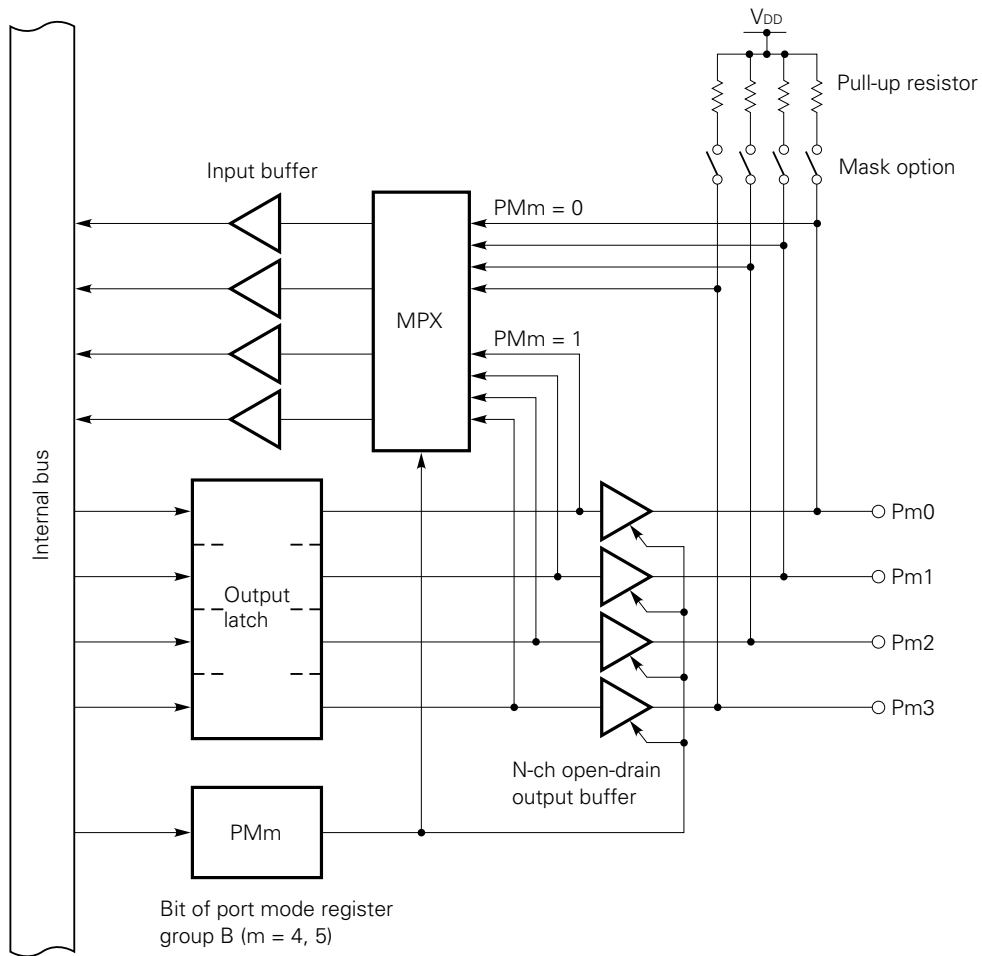

Fig. 4-6 Configuration of Port 7

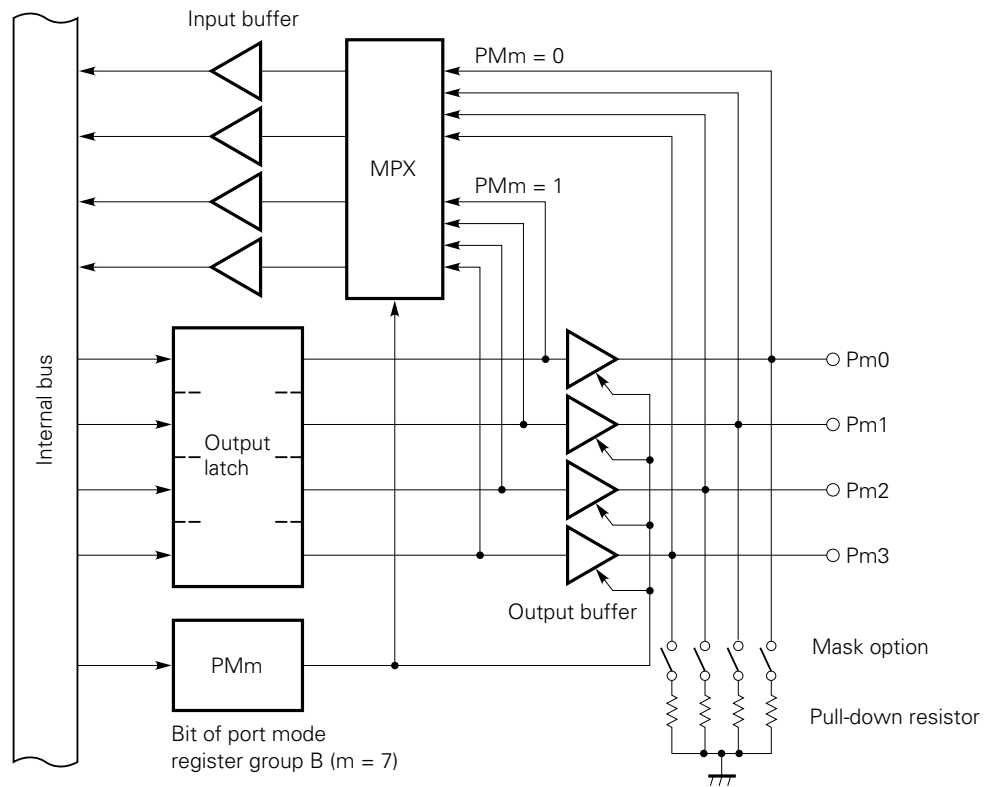

Fig. 4-7 Configuration of Port 9

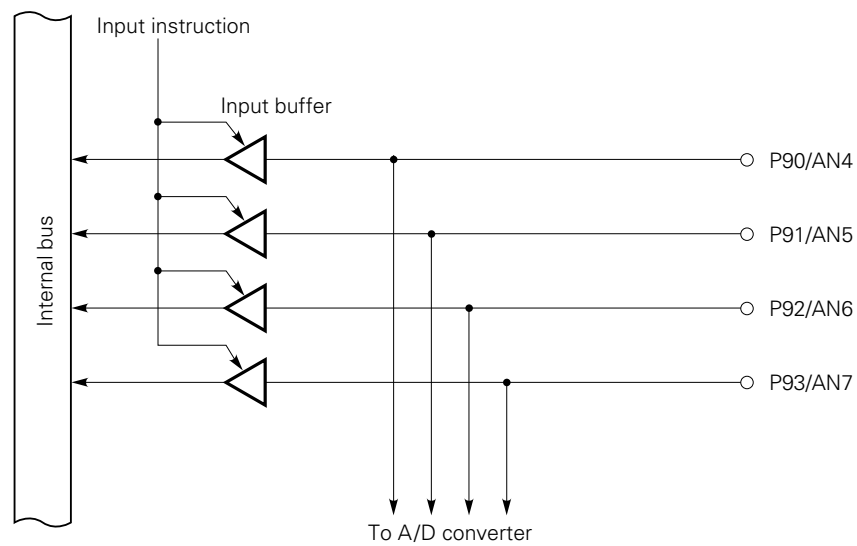
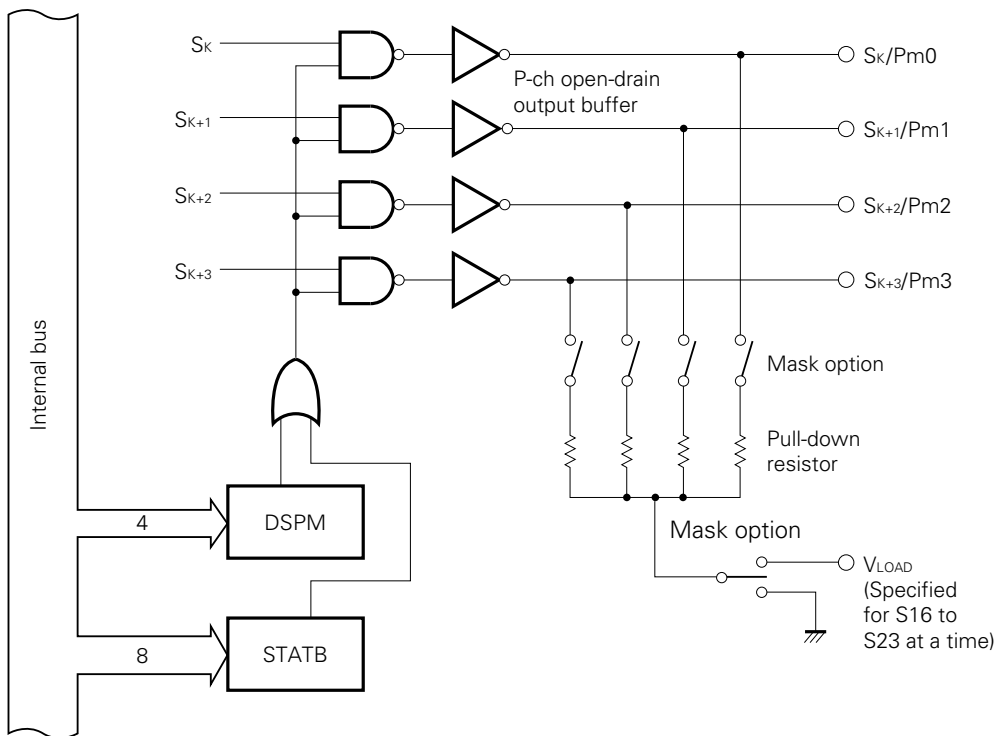
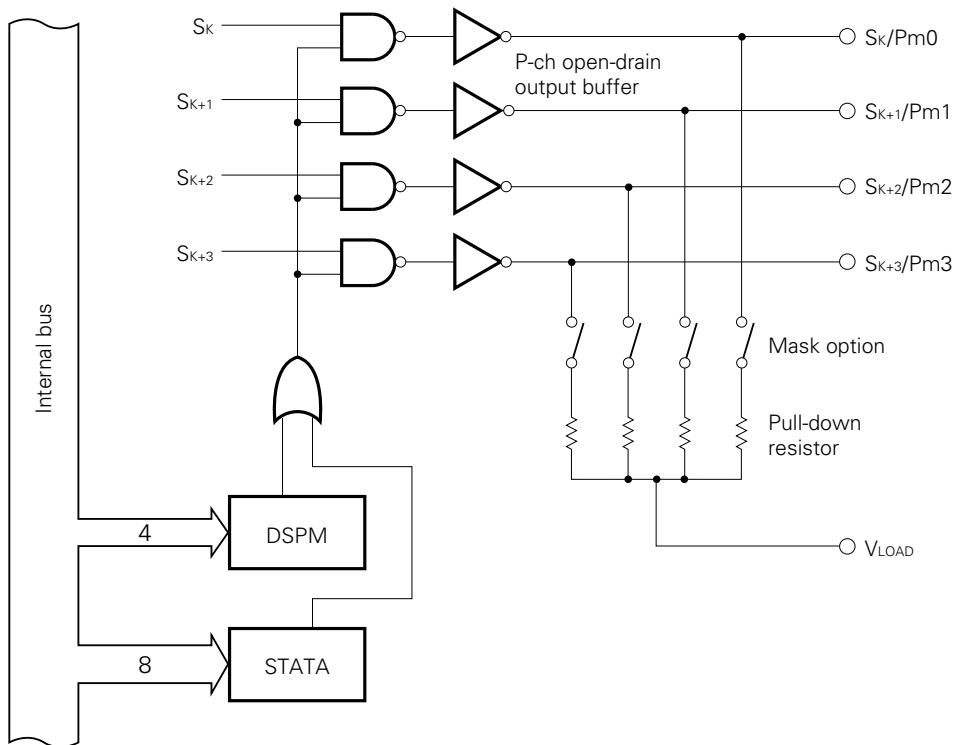

Fig. 4-8 Configuration of Ports 10 and 11



- Remarks 1. Port 10: $K = 16, m = 10$
- 2. Port 11: $K = 20, m = 11$

Fig. 4-9 Configuration of Ports 12 and 13



- Remarks 1. Port 12: $K = 0, m = 12$
- 2. Port 13: $K = 4, m = 13$

Fig. 4-10 Configuration of Port 14

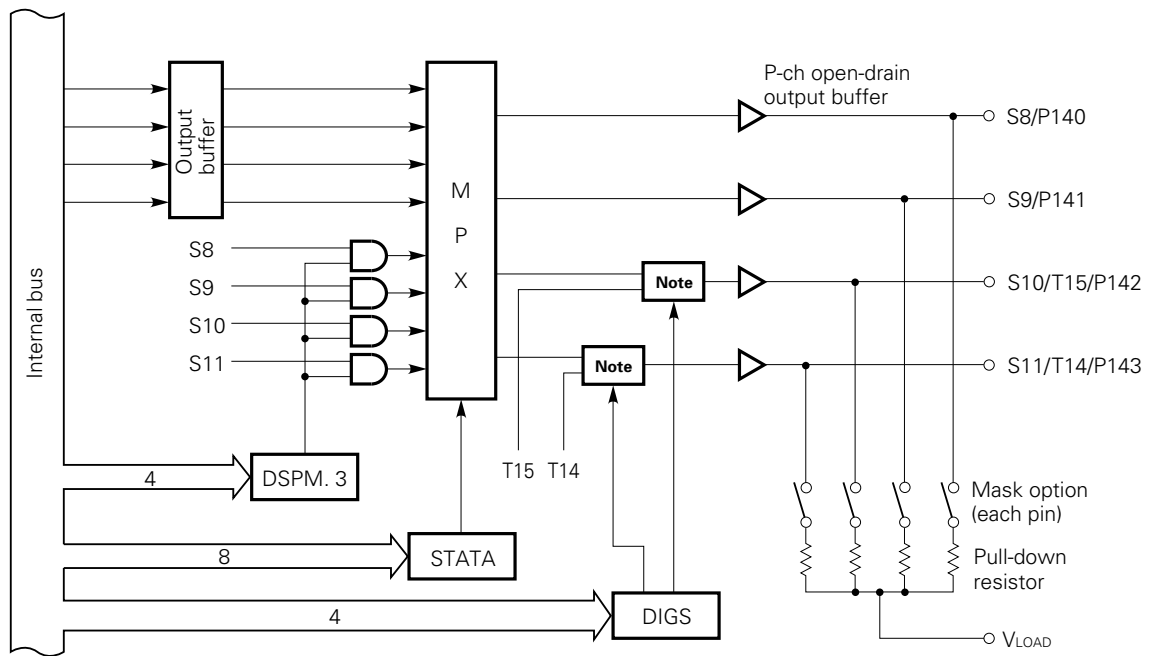

Note Selector

Fig. 4-11 Configuration of Ports 15 and H

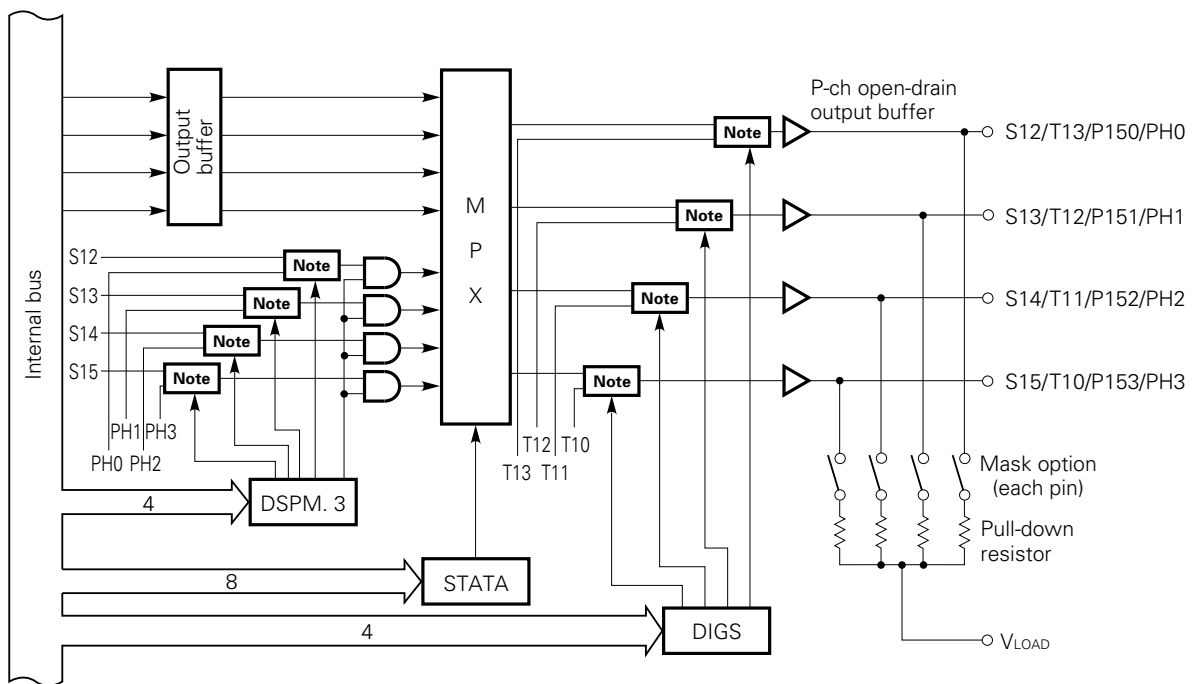

Note Selector

Fig. 4-12 Formats of the Port Mode Registers

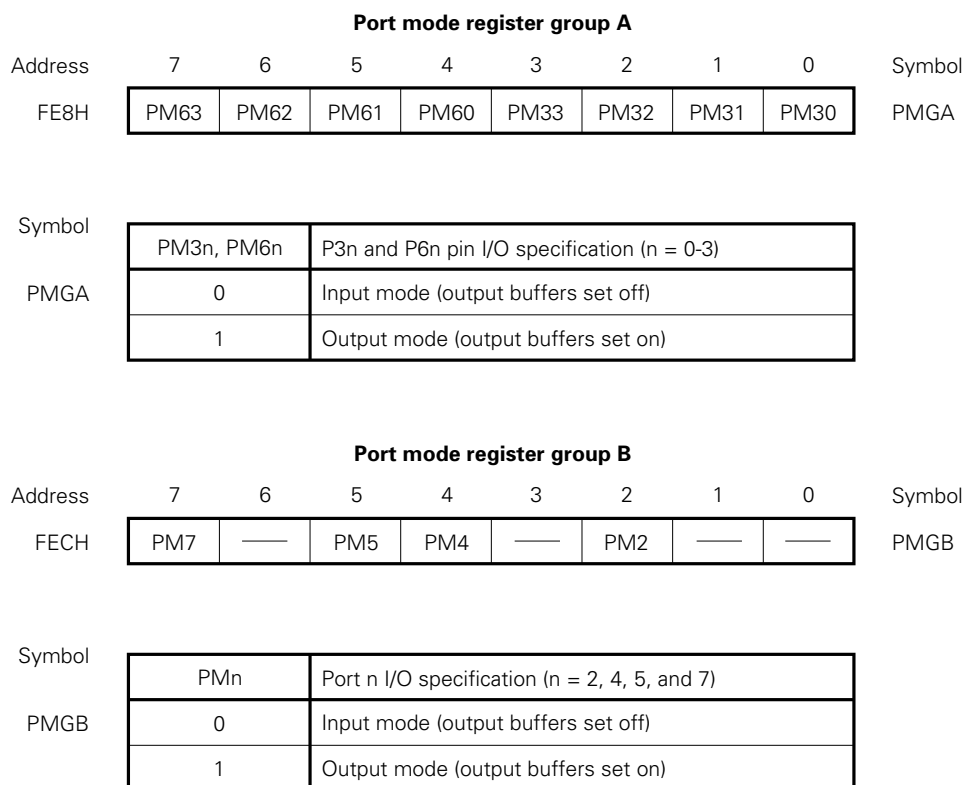

Remark —: Don't care

(4) Pull-up resistor register group A (POGA)

Pull-up resistor register group A is a register to specify an internal pull-up resistor to each port pin of ports 0 to 3 and port 6 (excluding P00). Fig. 4-13 shows the format of this register.

When a pull-up resistor is to be contained, set 1 to an associated bit, and when a pull-up resistor is not to be contained, set 0.

Fig. 4-13 Format of the Register Group A Specifying the Use of Pull-Up Resistors

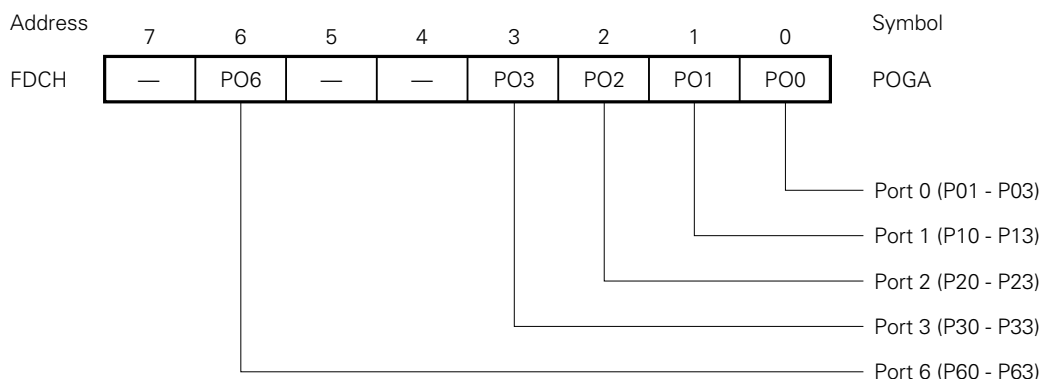

Caution For mask option, ports 4 and 5 can contain pull-up resistors, and port 7 and ports 10 to 15 can contain pull-down resistors bit by bit.

Remark —: Don't care

4.2 CLOCK GENERATOR

(1) Configuration of the clock generator

The clock generator supplies various clock signals to the CPU and peripheral hardware. Fig. 4-14 shows the configuration of the clock generator.

Fig. 4-14 Block Diagram of the Clock Generator

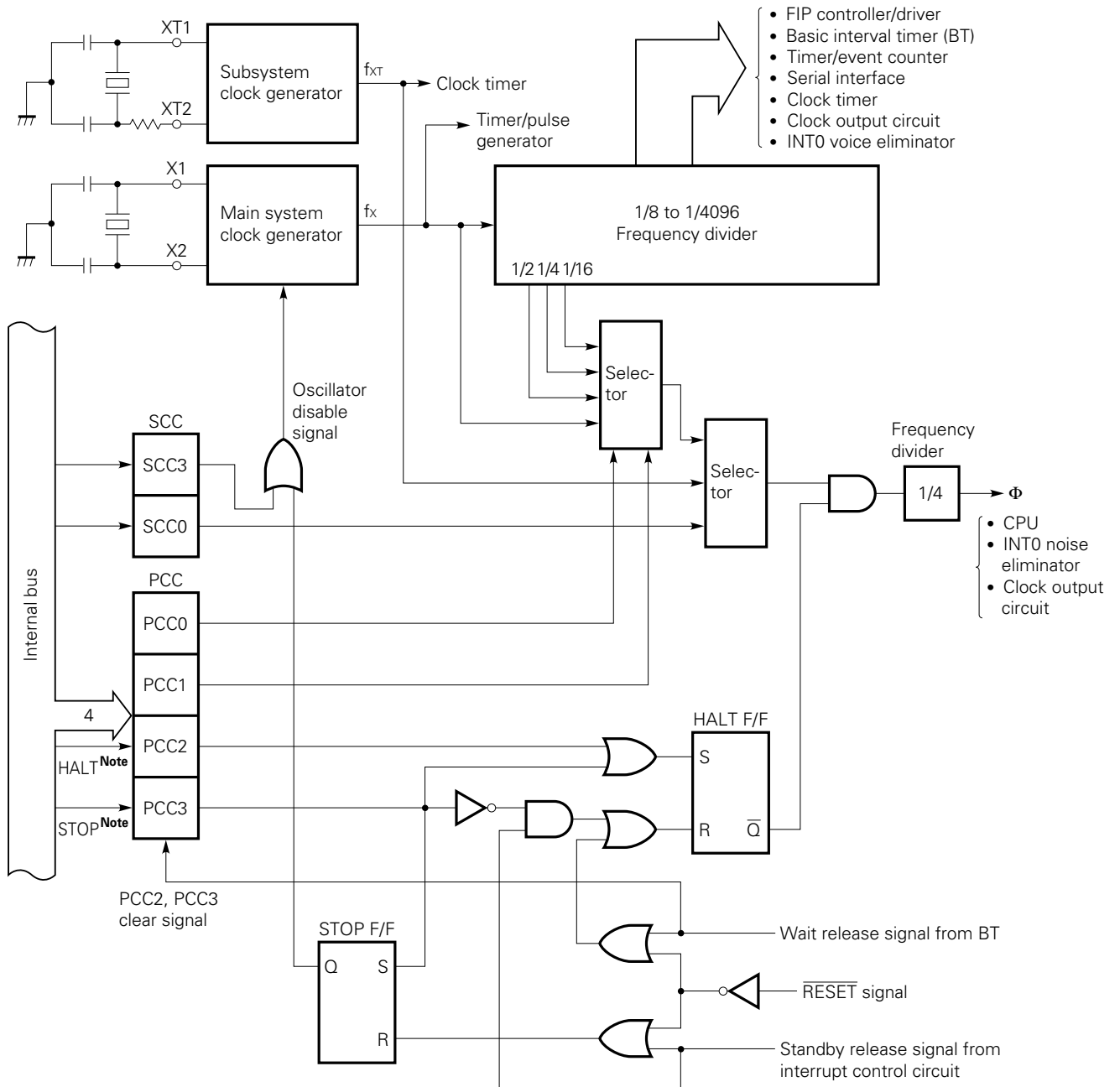

Note Instruction execution

Remarks 1. f_X : Main system clock frequency

2. f_{XT}: Subsystem clock frequency

3. Φ = CPU clock

4. PCC: Processor clock control register

5. SCC: System clock control register

6. One clock cycle (t_{CV}) of the CPU clock (Φ) is equal to one machine cycle of an instruction. See

Chapter 11 for details of t_{CV}.

(2) Functions of the clock generator

The clock generator generates the clock signals listed below, and controls the standby mode and other CPU operation modes.

- Main system clock: f_x
- Subsystem clock: f_{XT}
- CPU clock: Φ
- Clocks for peripheral hardware

The operation of the clock generator is determined by the processor clock control register (PCC) and system clock control register (SCC). The clock generator functions and operates as described below.

- (a) A $\overline{\text{RESET}}$ input selects the lowest-speed mode ($10.7 \mu\text{s}$ at 6.0 MHz)^{Note 1} for the main system clock. (PCC = 0, SCC = 0)
- (b) When the main system clock is selected, the PCC can be set to select one of four CPU clocks ($0.67 \mu\text{s}$, $1.33 \mu\text{s}$, $2.67 \mu\text{s}$, and $10.7 \mu\text{s}$ at 6.0 MHz)^{Note 2}.
- (c) When the main system clock is selected, the two standby modes, STOP mode and HALT mode, are available.
- (d) The SCC can be set to select the subsystem clock for very low-speed, low-current operation ($122 \mu\text{s}$ at 32.768 kHz).
- (e) When the subsystem clock is selected, main system clock generation can be stopped with the SCC. In addition, the HALT mode can be used, but the STOP mode cannot be used. (Subsystem clock generation cannot be stopped.)
- (f) Clocks for peripheral hardware are produced by dividing the main system clock signal. Only to the watch timer, the subsystem clock can be directly supplied to continue the clock function.
- (g) When the subsystem clock is selected, the watch timer can operate normally, but other hardware cannot be used because they operate with the main system clock.

Notes 1. $15.3 \mu\text{s}$ at 4.19 MHz

2. $0.95 \mu\text{s}$, $1.91 \mu\text{s}$, $3.82 \mu\text{s}$, $15.3 \mu\text{s}$ at 4.19 MHz

(3) Processor clock control register (PCC)

The PCC is a 4-bit register for selecting CPU clock Φ with the low-order two bits and for selecting a CPU operation mode with the high-order two bits. (See **Fig. 4-15**.)

When bit 3 or bit 2 is set to 1, the standby mode is set. When this is released by the standby release signal, these bits are automatically cleared to return to the normal operation mode. (See **Chapter 6** for detailed information.)

A 4-bit memory manipulation instruction is used to set the low-order two bits of the PCC. (The high-order two bits are set to 0.)

Bit 3 and bit 2 are set to 1 using the STOP instruction and HALT instruction, respectively.

The STOP instruction and HALT instruction can be executed regardless of MBE setting.

A CPU clock can be selected only when the main system clock is used for operation. When the subsystem clock is selected for operation, the low-order two bits of the PCC are invalidated, and $f_{XT}/4$ is automatically set. The STOP instruction can be executed only when the main system clock is used for operation.

The generation of a $\overline{\text{RESET}}$ signal clears the PCC to 0.

Fig. 4-15 Format of the Processor Clock Control Register

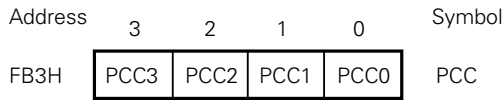

CPU clock selection bit

(Operation with $f_x = 6.0$ MHz)

		SCC = 0 () indicates $f_x = 6.0$ MHz		SCC = 1 () indicates $f_{XT} = 32.768$ kHz	
		CPU clock frequency	1 machine cycle	CPU clock frequency	1 machine cycle
0	0	$\Phi = f_x/64$ (93.7 kHz)	10.7 μs	$\Phi = f_{XT}/4$ (8.192 kHz)	122 μs
0	1	$\Phi = f_x/16$ (375 kHz)	2.67 μs	Not to be set	
1	0	$\Phi = f_x/8$ (750 kHz)	1.33 μs	$\Phi = f_{XT}/4$ (8.192 kHz)	122 μs
1	1	$\Phi = f_x/4$ (1.5 MHz)	0.67 μs		

(Operation with $f_x = 4.19$ MHz)

		SCC = 0 () indicates $f_x = 4.19$ MHz		SCC = 1 () indicates $f_{XT} = 32.768$ kHz	
		CPU clock frequency	1 machine cycle	CPU clock frequency	1 machine cycle
0	0	$\Phi = f_x/64$ (65.5 kHz)	15.3 μs	$\Phi = f_{XT}/4$ (8.192 kHz)	122 μs
0	1	$\Phi = f_x/16$ (262 kHz)	3.82 μs	Not to be set	
1	0	$\Phi = f_x/8$ (524 kHz)	1.91 μs	$\Phi = f_{XT}/4$ (8.192 kHz)	122 μs
1	1	$\Phi = f_x/4$ (1.05 MHz)	0.95 μs		

- Remarks** 1. f_x : Output frequency from the main syem clock oscillator
 2. f_{XT} : Output frequency from the subsyem clock oscillator

CPU operation mode control bits

0	0	Normal operation mode
0	1	HALT mode
1	0	STOP mode
1	1	Not to be set

(4) System clock control register (SCC)

The SCC is a 4-bit register for selecting CPU clock Φ with the least significant bit and for controlling the termination of main system clock generation with the most significant bit. (See Fig. 4-16.)

SCC.0 and SCC.3 are located at the same data memory address, but both bits cannot be changed at the same time. Accordingly, SCC.0 and SCC.3 are set using bit manipulation instructions. SCC.0 and SCC.3 can be manipulated regardless of MBE setting.

Main system clock generation can be terminated by setting SCC.3 only when the subsystem clock is used for operation. The STOP instruction must be used for generation termination when the main system clock is used for operation.

A $\overline{\text{RESET}}$ input clears the SCC to 0.

Fig. 4-16 Format of the System Clock Control Register

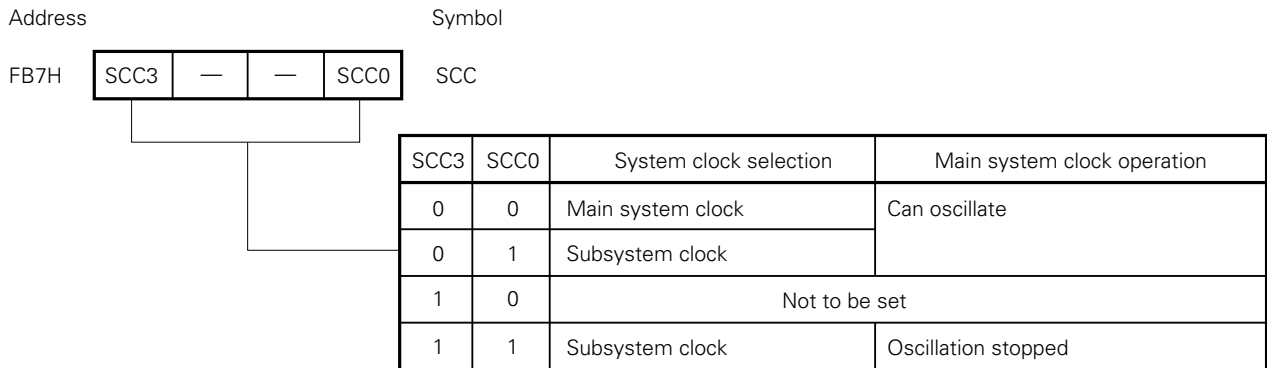

- Cautions**
- 1. A time period of up to $1/f_{XT}$ is needed to change the system clock. This means that to terminate main system clock generation, SCC.3 must be set when the machine cycles indicated in Table 4-2 or more have elapsed after the clock is switched from the main system clock to the subsystem clock.**
 - 2. When the main system clock is used for operation, setting SCC.3 to stop clock generation does not enter the normal STOP mode.**
 - 3. When SCC.3 is set to 1, the X1 input pin is connected to V_{SS} (GND electric potential) to prevent leakage in the crystal oscillator. When an external clock is used as the main system clock, never set SCC.3 to 1.**
 - 4. When the four bits of PCC are set to 0001B ($\Phi = f_x/16$), do not set SCC.0 to 1. Before switching the main system clock to the subsystem clock, be sure to manipulate the PCC bits so other than 0001B is set. When the system operates on the subsystem clock, the PCC bits must also be other than 0001B.**

(5) System clock oscillator

The main system clock oscillator operates with a crystal (6.0 MHz standard) or ceramic resonator connected to the X1 and X2 pins.

An external clock can also be input.

Fig. 4-17 External Circuitry for the Main System Clock Oscillator

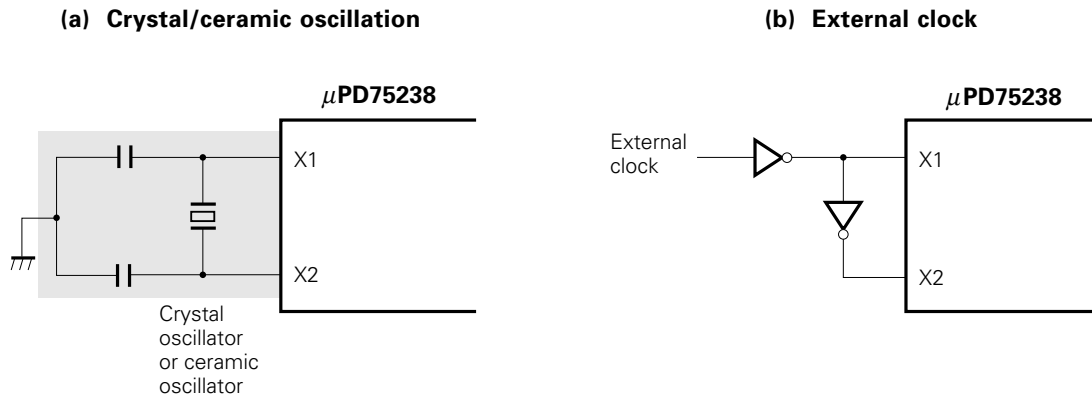

Caution When an external clock is used, the STOP mode cannot be set. This is because the X1 pin is connected to V_{SS} in the STOP mode.

The subsystem clock oscillator operates with a crystal resonator (32.768 kHz standard) connected to the XT1 and XT2 pins.

An external clock can also be input.

Fig. 4-18 External Circuitry for the Subsystem Clock Oscillator

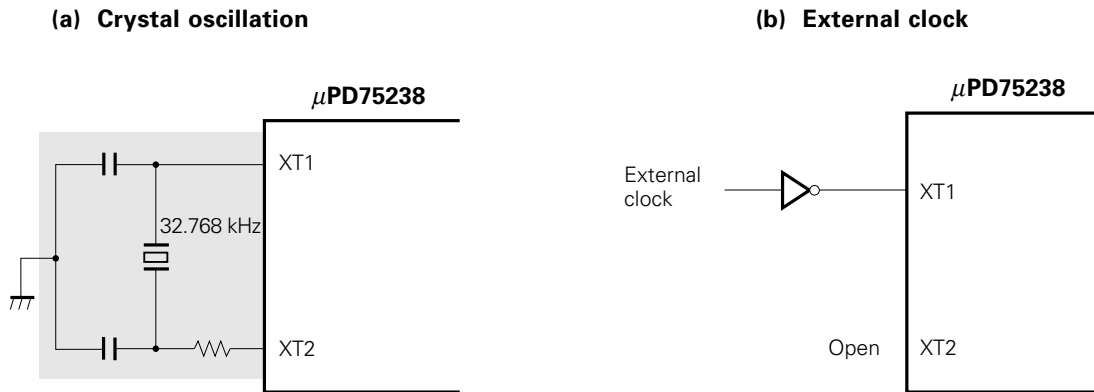

Caution When the main system clock or subsystem clock oscillator is used, conform to the following guidelines when wiring at the shaded portions of Fig. 4-17 and 4-18 to eliminate the influence of the wiring capacity.

- The wiring must be as short as possible.
- Other signal lines must not run in these areas. Any line carrying a high fluctuating current must be kept away as far as possible.
- The grounding point of the capacitor of the oscillator must have the same potential as that of V_{ss}. It must not be grounded to ground patterns carrying a large current.
- No signal must be taken from the oscillator.

When the subsystem clock is used, pay special attention to its wiring; the subsystem clock oscillator has low amplification to minimize current consumption and is more likely to malfunction due to noise than the main system clock oscillator.

(6) Time required to change the system clock and CPU clock

The system clock and CPU clock can be changed by using the least significant bit of the SCC and the low-order two bits of the PCC. This switching is not performed immediately after the contents of the registers are rewritten, but the system operates with the previous clock for some machine cycles. Accordingly, after this time period, the STOP instruction must be executed or SCC.3 must be set to 1 to terminate main system clock generation.

Table 4-2 Maximum Time Required to Change the System Clock and CPU Clock

Setting before switching			Setting after switching														
SCC	PCC	PCC	SCC0	PCC1	PCC0	SCC0	PCC1	PCC0	SCC0	PCC1	PCC0	SCC0	PCC1	PCC0	SCC0	PCC1	PCC0
0	1	0	0	0	0	0	0	1	0	1	0	0	1	1	1	×	×
0	0	0	/			1 machine cycle			1 machine cycle			1 machine cycle			f _x / 64f _{xT} machine cycles (3 machine cycles)		
	0	1				4 machine cycles			4 machine cycles			4 machine cycles			Not to be set		
	1	0				8 machine cycles			8 machine cycles			8 machine cycles			f _x / 8f _{xT} machine cycles (23 machine cycles)		
	1	1				16 machine cycles			16 machine cycles			16 machine cycles			f _x / 4f _{xT} machine cycles (46 machine cycles)		
1	×	×	1 machine cycle			Not to be set			1 machine cycle			1 machine cycle			/		

- Remarks**
1. CPU clock Φ is supplied to the CPU in the μPD75238. The reciprocal of this frequency is a minimum instruction time (defined as one machine cycle in this manual).
 2. Time enclosed in parentheses is required when f_x = 6.0 MHz and f_{xT} = 32.768 kHz.

Caution When the four bits of PCC are set to 0001B (Φ = f_x / 16), do not set SCC.0 to 1. Before switching the main system clock to the subsystem clock, be sure to manipulate the PCC bits so other than 0001B is set. When the system operates on the subsystem clock, the PCC bits must also be other than 0001B.

(7) Procedure for changing the system clock and CPU clock

The procedure for changing the system clock and CPU clock is explained using Fig. 4-19.

Fig. 4-19 Changing the System Clock and CPU Clock

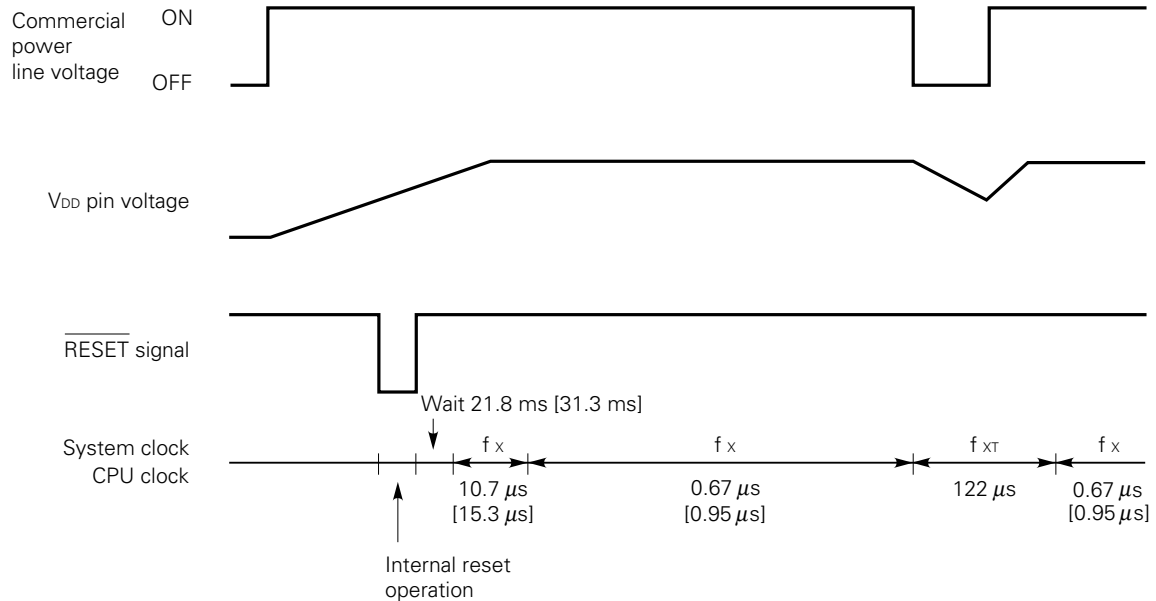

Remark The values not enclosed in square brackets are for $f_x = 6.0$ MHz and $f_{XT} = 32.768$ kHz; the values enclosed in square brackets for $f_x = 4.19$ MHz.

- ① A $\overline{\text{RESET}}$ input starts CPU operation at the lowest speed of the main system clock ($10.7 \mu s$ at 6.0 MHz)^{Note 1} after a wait time (21.8 ms at 6.0 MHz)^{Note 2} for stable oscillation.
- ② The PCC is rewritten for highest-speed operation after a time elapse which is sufficient for the voltage on the V_{DD} pin to be high enough for highest-speed operation.
- ③ The removal of commercial power is detected using, for example, an interrupt input (INT4 is useful), then SCC.0 is set to operate with the subsystem clock. (In this case, the start of subsystem clock generation must be confirmed beforehand.) After a time (32 machine cycles) required to switch to the subsystem clock elapses, SCC.3 is set to terminate main system clock generation.
- ④ After detecting the input of commercial power by using an interrupt, SCC.3 is cleared to start main system clock generation. After a time required for stable generation, SCC.0 is cleared to operate at highest speed.

Notes 1. 15.3 μs at 4.19 MHz

2. 31.3 ms at 4.19 MHz

4.3 CLOCK OUTPUT CIRCUIT

(1) Configuration of the clock output circuit

Fig. 4-20 shows the configuration of the clock output circuit.

(2) Functions of the clock output circuit

The clock output circuit outputs a clock pulse signal on the P22/PCL pin for remote control or for supplying clock pulses to a peripheral LSI device.

The procedure for outputting a clock pulse signal is as follows:

- (a) Select a clock output frequency, and disable clock output.
- (b) Write a 0 in the P22 output latch.
- (c) Set the output mode for port 2.
- (d) Enable clock output.

Fig. 4-20 Configuration of the Clock Output Circuit

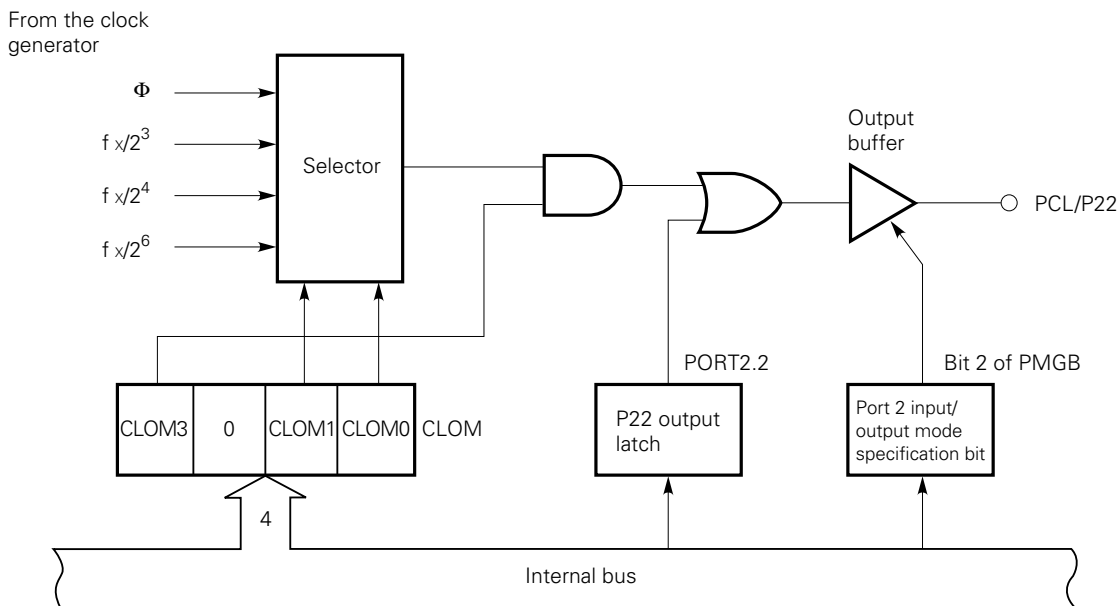

Remark The clock output circuit is designed so that pulses with short widths do not appear in enabling or disabling clock output.

(3) Clock output mode register (CLOM)

The CLOM is a 4-bit register to control clock output.

The CLOM is set with a 4-bit memory manipulation instruction. No read operation is allowed on this register.

Example CPU clock Φ is output on the PCL/P22 pin.

```
SEL MB15 ; Or CLR1 MBE
MOV A, #1000B
MOV CLOM, A
```

A RESET input clears the CLOM to 0, disabling clock output.

Fig. 4-21 Format of the Clock Output Mode Register

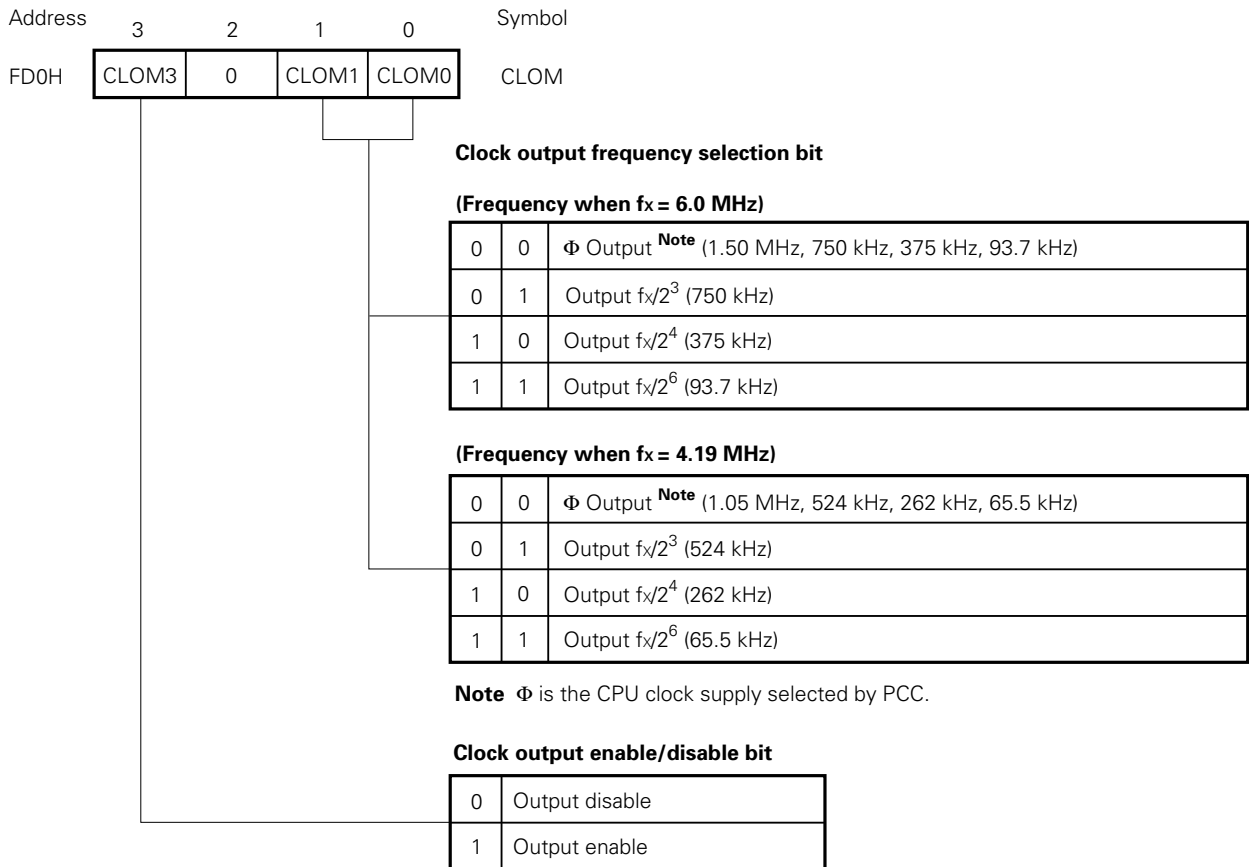

Caution Be sure to write a 0 in bit 2 of the CLOM.

(4) Application to remote control output

The clock output function of the μPD75238 is applicable to remote control output. The frequency of the carrier for remote control output is selected by the clock frequency select bit of the clock output mode register. Pulse output is enabled or disabled by controlling the clock output enable/disable bit by software. The clock output circuit is designed so that pulses with short widths do not appear in enabling or disabling clock output.

Fig. 4-22 Application to Remote Control Output

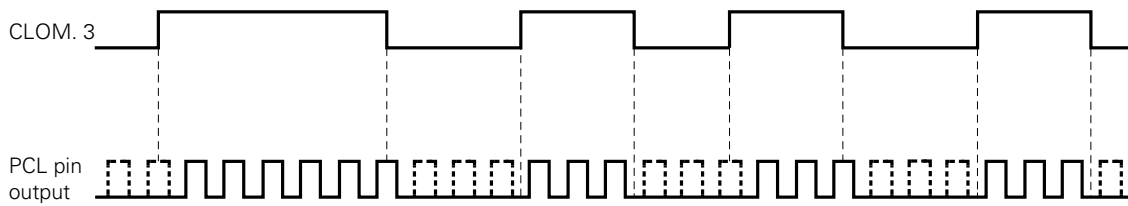

4.4 BASIC INTERVAL TIMER

(1) Configuration of the basic interval timer

Fig. 4-23 shows the configuration of the basic interval timer.

(2) Basic interval timer functions

The basic interval timer provides the following four functions:

- (a) Reference time generation (four time intervals)
- (b) Application of watchdog timer for detecting program crashes
- (c) Selection of a wait time for releasing the standby mode, and counting
- (d) Reading the count value

Fig. 4-23 Configuration of the Basic Interval Timer

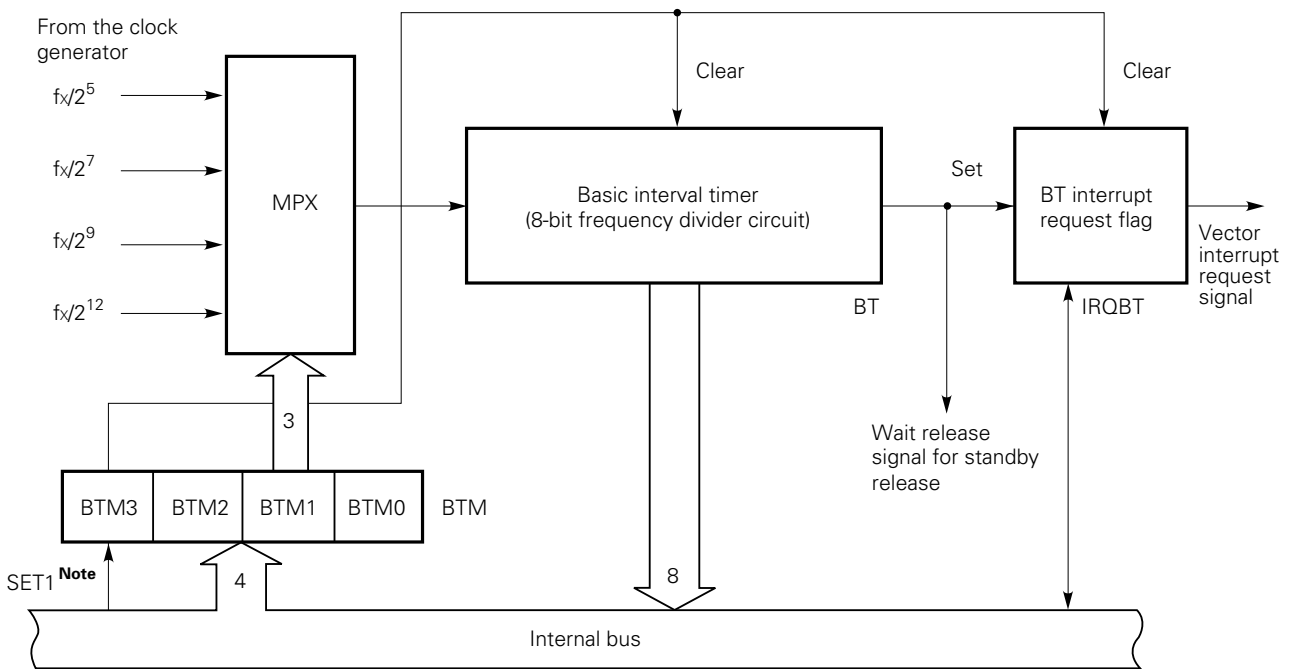

Note Instruction execution

(3) Basic interval timer mode register (BTM)

BTM is a 4-bit register that controls operation of the basic interval timer.

The BTM contents are set by using a 4-bit memory manipulation instruction.

Bit 3 can be independently set using a bit manipulation instruction.

When bit 3 is set to 1, the contents of the basic interval timer are cleared, and the basic interval timer interrupt request flag (IROBT) is also cleared (to start the basic interval timer).

A RESET input clears the contents to 0, and the longest interrupt request signal generation interval time is set.

Fig. 4-24 Format of the Basic Interval Timer Mode Register

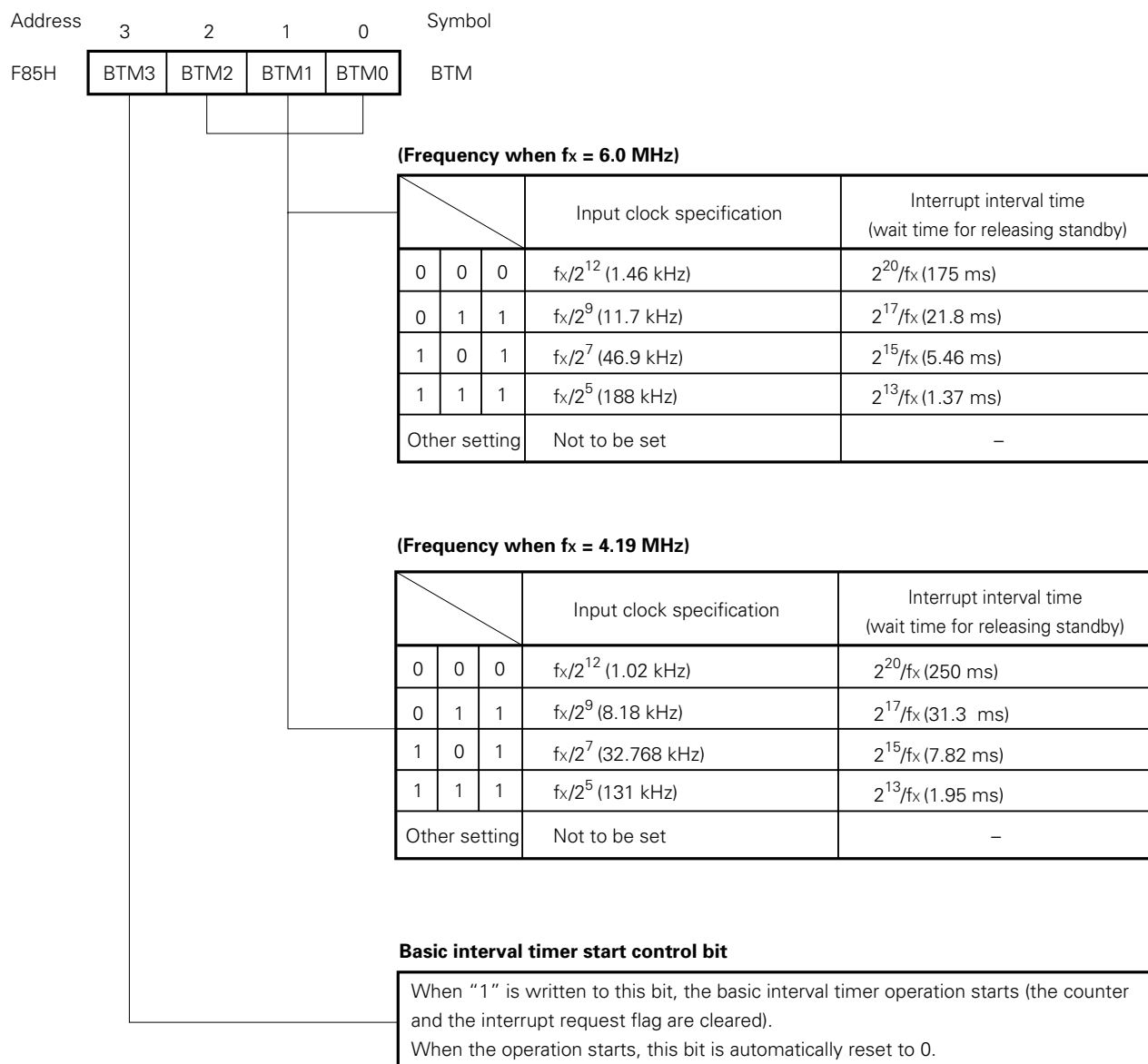

(4) Operation of the basic interval timer

The basic interval timer (BT) is always incremented by the clock supplied from the clock generator, and when it overflows, the interrupt request flag (IRQBT) is set. The count operation of BT cannot be stopped. One of four interrupt generation intervals can be selected by setting BTM. (See Fig. 4-24.)

The basic interval timer and the interrupt request flag can be cleared by setting bit 3 of BTM to 1 (instruction for starting as an interval timer).

The count status can be read by using an 8-bit manipulation instruction. No data can be loaded to the timer.

Caution When reading the count value of the basic interval timer, execute a read instruction twice so that unstable data which has been counted will not be read. If the two read values are reasonable, use the second one as the result. If the two read values are far apart, retry from the beginning.

To allow the system clock to stabilize after releasing the STOP mode, a wait function is available which stops the operation of the CPU until the basic interval timer overflows.

The wait time after a $\overline{\text{RESET}}$ input is fixed. On the other hand, a wait time can be selected by setting BTM when releasing the STOP mode with an interrupt occurrence. In this case, the wait times are the same as the interval times shown in Fig. 4-24.

BTM must be set before the STOP mode is set. (For details, see Chapter 6.)

4.5 TIMER/EVENT COUNTER**(1) Functions of the timer/event counter**

The timer/event counter has the following functions.

- (a) Programmable interval timer operation
- (b) Output of a square wave at a given frequency to the PTO0 pin
- (c) Event counter operation
- (d) Frequency divider operation that divides TIO pin input by N and outputs the result to the PTO0 pin
- (e) Supply of serial shift clock signal to a serial interface circuit
- (f) Function of reading the state of counting

Fig. 4-25 Block Diagram of the Timer/Event Counter

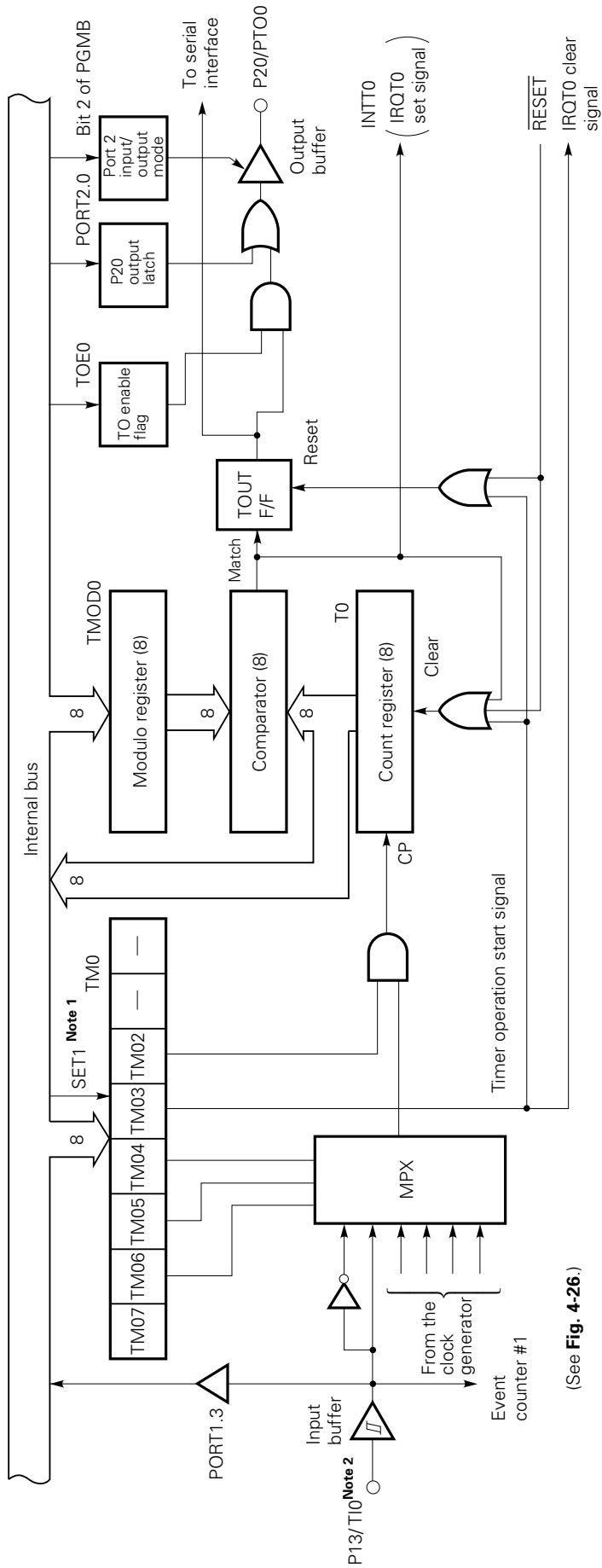

(See Fig. 4-26.)

- Notes**
1. Instruction execution
 2. The P13/T10 pin is an external event pulse input pin shared between timer/event counter and event counter.

(2) Timer/event counter mode register (TM0) and timer/event counter output enable flag (TOE0)

The timer/event counter mode register (TM0) is an 8-bit register for controlling the timer/event counter. It is set by an 8-bit memory manipulation instruction.

Fig. 4-27 shows the format of the timer/event counter mode register.

Bit 3 is the timer start bit, and can be set independently of the other bits. Bit 3 is automatically reset to 0 when the timer starts operation.

A $\overline{\text{RESET}}$ input clears all the bits of the TM0 to 0.

The timer/event counter output enable flag (TOE0) enables or disables output of the timer out F/F (TOUT F/F) status to the PTO0 pin.

Fig. 4-26 shows the format of the timer/event counter output enable flag.

The timer out F/F (TOUT F/F) can be inverted by a match signal sent out from the comparator. The timer out F/F is reset when an instruction sets bit 3 of the TM0.

A $\overline{\text{RESET}}$ input clears the TOE0 and TOUT F/F to 0.

Fig. 4-26 Format of the Timer/Event Counter Output Enable Flag

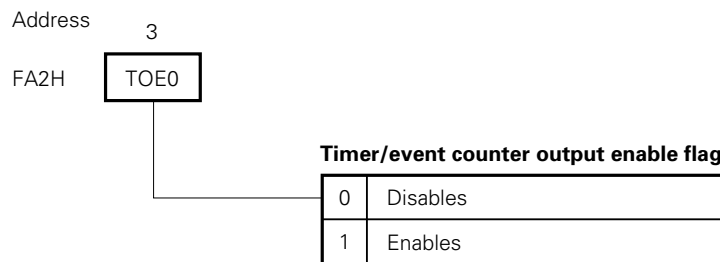
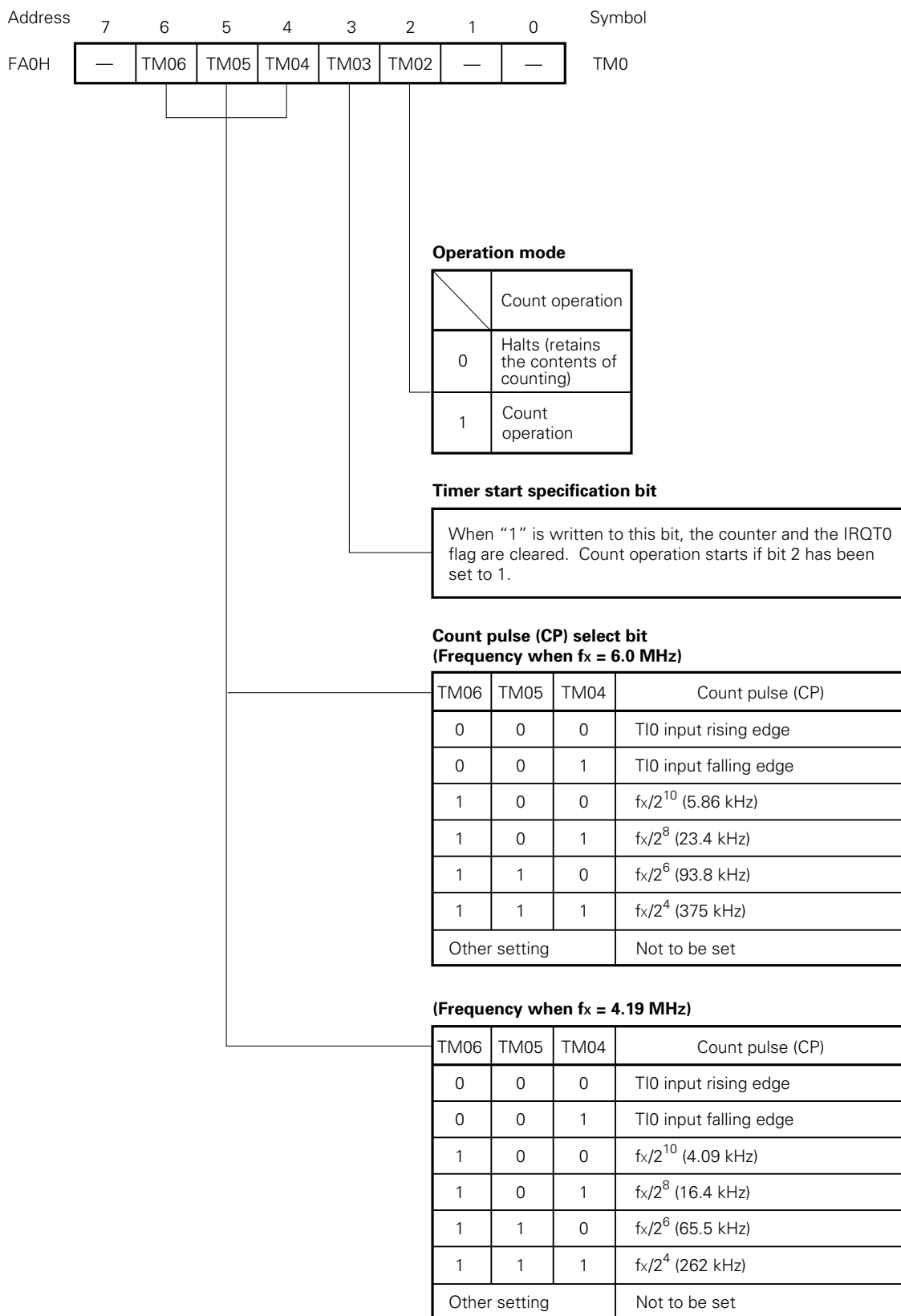

Fig. 4-27 Format of the Timer/Event Counter Mode Register



(3) Operation mode of the timer/event counter

The timer/event counter operates in the count operation disable mode or in the count operation mode, depending on the setting of the mode register.

The following operations are possible, regardless of the setting of the mode register:

- (i) P13/TI0 pin signal input and test
- (ii) Output of the timer out F/F status to the PTO0
- (iii) Setting of the modulo register (TMOD0)
- (iv) Reading from the count register (T0)
- (v) Setting, clearing, and testing of the interrupt request flag (IRQT0)

(a) Count operation disable mode

This mode is set when bit 2 of TM0 is set to 0. In this mode, count operation is not performed because count pulse (CP) supply to the count register is stopped.

(b) Count operation mode

This mode is set when bit 2 of TM0 is set to 1. In this mode, a count pulse signal selected with bits 4 to 6 is supplied to the count register for count operation as shown in Fig. 4-28.

Timer operation is usually started in the following steps:

- ① A count value is set in the modulo register (TMOD0).
- ② An operation mode, count clock, and start instruction are set in the mode register (TM0).

An 8-bit data transfer instruction is used to set the modulo register.

Fig. 4-28 Operation in the Count Operation Mode

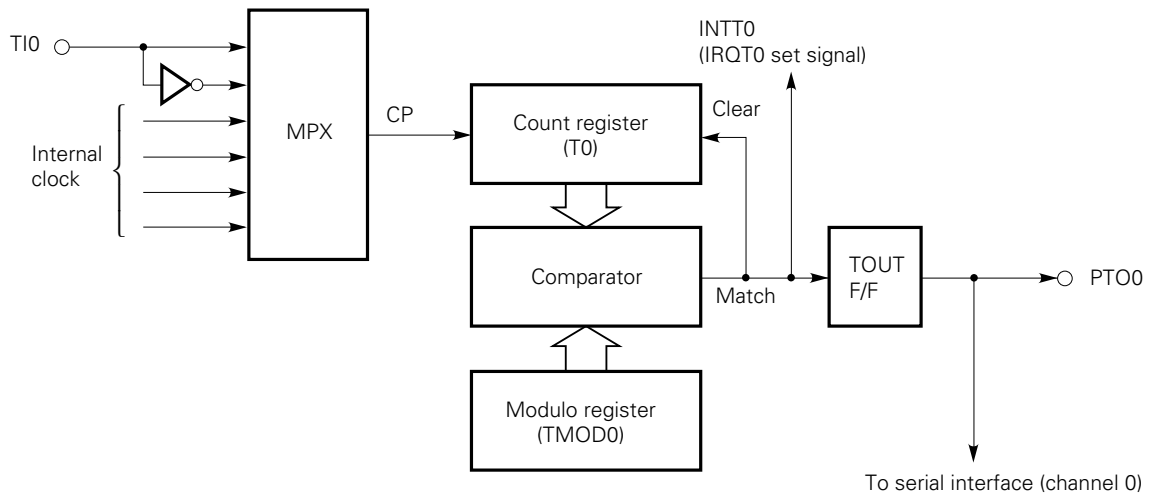

(4) Time setting in the timer/event counter

[Timer set time] (period) is [value of the modulo register + 1] divided by [count pulse frequency] selected by the timer mode register.

$$T(\text{sec}) = \frac{(n + 1)}{f_{CP}} = (n + 1) \cdot (\text{resolution})$$

T(sec) : Timer set time (seconds)

f_{CP} (Hz): Count pulse frequency (Hz)

n : Value in the modulo register (n ≠ 0)

Once the timer is set, the interrupt request signal (IRQT0) is generated at set time intervals. Table 4-3 indicates the resolution and maximum set time (set when FFH is set in the modulo register) of the timer/event counter for each count pulse signal.

Table 4-3 Resolution and Maximum Set Time

(When f_x = 6.0 MHz)

Mode register			Timer channel 0	
TM06	TM05	TM04	Resolution	Maximum set time
1	0	0	171 μs	43.7 ms
1	0	1	42.7 μs	10.9 ms
1	1	0	10.7 μs	2.73 ms
1	1	1	2.67 μs	683 μs

(When f_x = 4.19 MHz)

Mode register			Timer channel 0	
TM06	TM05	TM04	Resolution	Maximum set time
1	0	0	244 μs	62.5 ms
1	0	1	61.1 μs	15.6 ms
1	1	0	15.3 μs	3.91 ms
1	1	1	3.81 μs	977 μs

4.6 CLOCK TIMER

(1) Clock timer

The μPD75238 contains one channel for a clock timer. Fig. 4-29 shows the configuration of the timer.

(2) Clock timer functions

- (a) The clock timer sets the test flag (IRQW) every 0.5 seconds. The standby mode can be released with IRQW.
- (b) Either the main system clock (4.19 MHz) or subsystem clock (32.768 kHz) can produce 0.5-second intervals.
- (c) The fast-forward mode produces an interval 128 times faster (3.91 ms), which is useful for program debugging and testing.
- (d) A fixed frequency (2.048, 4.096, or 32.768 kHz) can be output to the P23/BUZ pin, so that it can be used for sounding the buzzer and system clock frequency trimming.
- (e) The frequency divider can be cleared, so the clock can start from zero seconds.

Fig. 4-29 Block Diagram of the Clock Timer

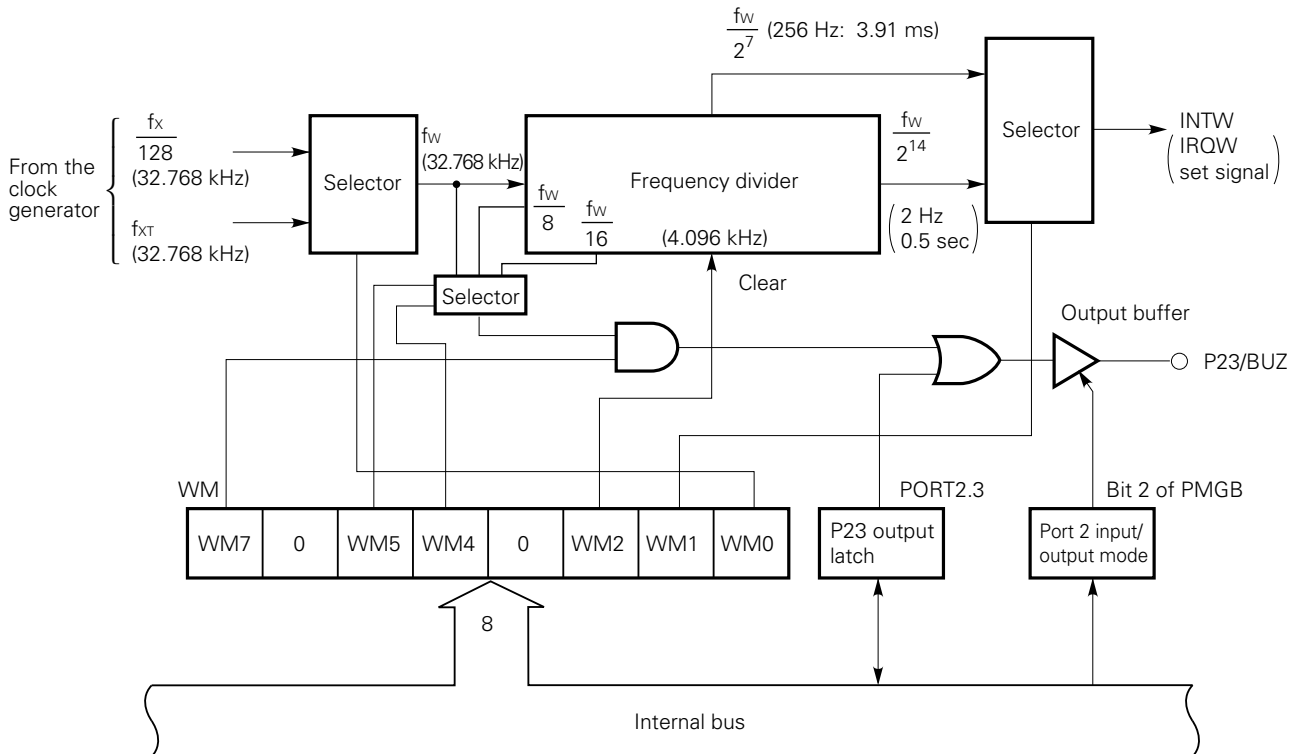

Remark The values in parentheses are for $f_x = 4.194304$ MHz and $f_{XT} = 32.768$ kHz

Caution When the main system clock operates at 6.0 MHz, a time interval of 0.5 s cannot be produced. Before producing this time interval, the main system clock must be changed to the subsystem clock.

(3) Watch mode register (WM)

The watch mode register (WM) is an 8-bit register that controls the clock timer, and that is set with an 8-bit memory manipulation instruction. Fig. 4-30 shows the format.

An 8-bit memory manipulation instruction is used to set the watch mode register. A $\overline{\text{RESET}}$ input clears all bits to 0.

Fig. 4-30 Format of the Clock Mode Register

Address	7	6	5	4	3	2	1	0	Symbol
F98H	WM7	0	WM5	WM4	0	WM2	WM1	WM0	WM

Count clock (fw) selection bit

WM0	0	Selects divided system clock output: $\frac{f_x}{128}$
	1	Selects subsystem clock: f_{XT}

Operation mode selection bit

WM1	0	Normal clock mode ($\frac{f_w}{2^{14}}$: sets IRQW at 0.5 s)
	1	Advanced clock mode ($\frac{f_w}{2^7}$: sets IRQW at 3.91 ms)

Clock operation enable/disable bit

WM2	0	Disables clock operation (clears the frequency dividing circuit)
	1	Enables clock operation

BUZ output frequency selection bit

WM5	WM4	BUZ output frequency
0	0	$f_w/2^4$ (2.048 kHz)
0	1	$f_w/2^3$ (4.096 kHz) ^{Note}
1	0	Not to be set
1	1	f_w (32.768 kHz) ^{Note}

Note Not supported by the IE-75000-R.

BUZ output enable/disable bit

WM7	0	Disables BUZ output
	1	Enables BUZ output

4.7 TIMER/PULSE GENERATOR

(1) Timer/pulse generator functions

The μ PD75238 contains one channel for a timer/pulse generator that can be used as a timer or a pulse generator. It has the following functions:

(a) Functions available when the timer/pulse generator is used in the timer mode

- 8-bit interval timer operation using one of five clock sources (occurrence of IRQTPG)
- Square wave output to the PPO pin

(b) Functions available when the timer/pulse generator is used in the PWM pulse generation mode

- PWM pulse output to the PPO pin with an accuracy of 14 bits (applicable for electronic tuning when used as an D/A converter)
- Generation of interrupts at regular intervals ($2^{15}/f_x = 5.46$ ms at 6.0 MHz)^{Note}

Note 7.81 ms at 4.19 MHz

If pulse output is unnecessary, the PPO pin can be used as a 1-bit output port.

Caution If the timer/pulse generator is operating when the STOP mode is set, it may malfunction. So the timer/pulse generator must be disabled with the mode register in advance.

(2) Timer/pulse generator mode register (TPGM)

The timer/pulse generator mode register (TPGM) is an 8-bit register that controls operation of the timer/pulse generator. Fig. 4-31 shows the format of the register.

TPGM is set with an 8-bit memory manipulation instruction.

Bit 3 enables or disables the transfer (reloading) of the timer/pulse generator modulo register (MODH and MODL) contents to the modulo latch. Bit 3 can be manipulated independently of the other bits.

By setting TPGM1 to 0, timer/pulse generator operation can be stopped to decrease current consumption.

A $\overline{\text{RESET}}$ input clears all bits to 0.

Fig. 4-31 Format of Timer/Pulse Generator Mode Register

Address	7	6	5	4	3	2	1	0	Symbol
F90H	TPGM7	—	TPGM5	TPGM4	TPGM3	0	TPGM1	TPGM0	TPGM

Timer/pulse generator operation mode selection bit

TPGM0	0	Select PWM pulse generation mode
	1	Select timer mode

Timer/pulse generator operation enable/disable bit

TPGM1	0	Disable timer/pulse generator operation
	1	Enable timer/pulse generator operation

Modulo register reload enable/disable bit

TPGM3	0	Disable reloading of modulo register
	1	Enable reloading of modulo register

PPO output latch data

TPGM4	0	Output 0 to PPO output latch
	1	Output 1 to PPO output latch

PPO pin output selection bit static/pulse

TPGM5	0	Static output on PPO pin
	1	Pulse output (square wave/PWM) on PPO pin

PPO pin output enable/disable bit

TPGM7	0	Disable output on PPO pin (high-impedance)
	1	Enable output on PPO pin

(3) Configuration and operation when the timer/pulse generator is used in the timer mode

Fig. 4-32 shows the configuration when the timer/pulse generator is used in the timer mode.

The timer mode is selected by setting bit 0 of TPGM to 1. In the timer mode, TPGM3 must be set to 1, allowing a modulo register to be reloaded at any time.

In the timer mode, a prescaler is selected with the modulo register L (MODL), and a frequency or interrupt interval value is set in the modulo register H (MODH). The timer starts when the TPGM1 is set to 1.

Fig. 4-33 shows the operation timing for the MODH setting, and Table 4-4 shows the setting of a frequency or interrupt interval.

The output to the PPO pin can be switched between the square wave output and static output. To output a square wave, set TPGM5 and TPGM7 to 1.

Fig. 4-32 Block Diagram of the Timer/Pulse Generator (Timer Mode)

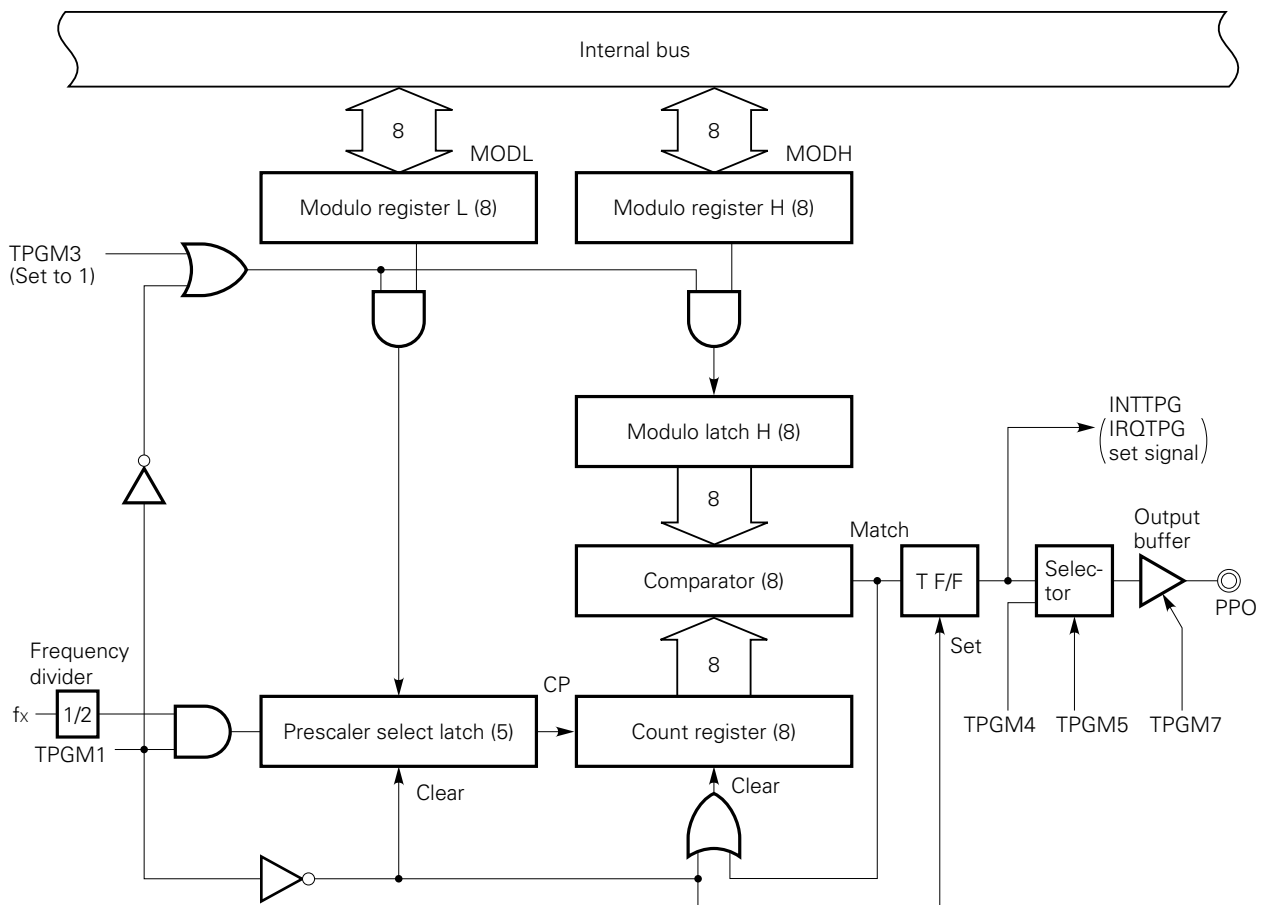

Caution When the timer operating in the timer operation mode is stopped, IRQTPG may be set because T F/F is set. So, the timer must be stopped with an interrupt being disabled, then IRQTPG must be cleared.

Fig. 4-33 Timer Mode Operation Timing

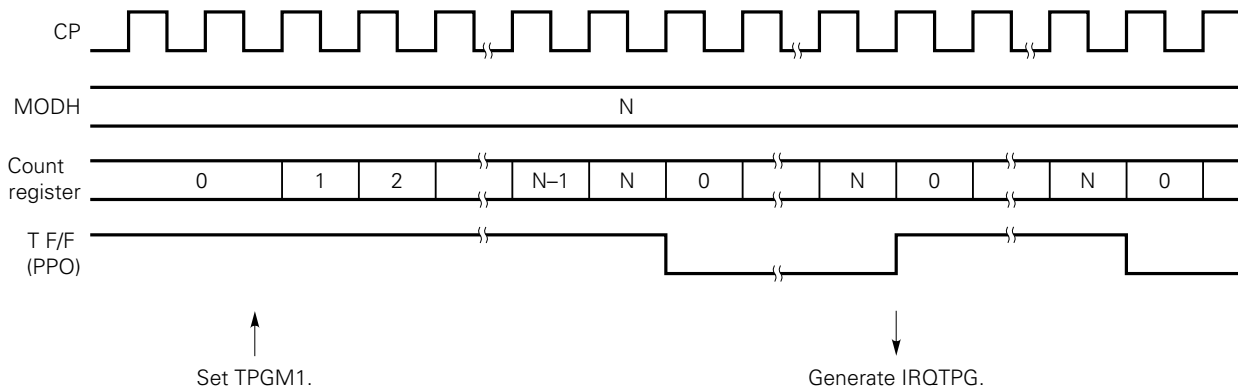

Table 4-4 Modulo Register Settings

(When $f_x = 6.0$ MHz)

MODL bits 2-6					Interrupt generation interval ($f_x = 6.0$ MHz)	Square wave output frequency ($f_x = 6.0$ MHz)
6	5	4	3	2		
0	0	0	0	1	$256 (N+1)/f_x = 85.3 \mu s - 10.9 ms$	$f_x/256 (N+1) = 91.6 Hz - 11.7 kHz$
0	0	0	1	0	$128 (N+1)/f_x = 42.7 \mu s - 5.45 ms$	$f_x/128 (N+1) = 183 Hz - 23.4 kHz$
0	0	1	0	0	$64 (N+1)/f_x = 21.3 \mu s - 2.73 ms$	$f_x/64 (N+1) = 366 Hz - 46.9 kHz$
0	1	0	0	0	$32 (N+1)/f_x = 10.7 \mu s - 1.37 ms$	$f_x/32 (N+1) = 732 Hz - 93.8 kHz$
1	0	0	0	0	$16 (N+1)/f_x = 5.33 \mu s - 683 \mu s$	$f_x/16 (N+1) = 1465 Hz - 188 kHz$

(When $f_x = 4.19$ MHz)

MODL bits 2-6					Interrupt generation interval ($f_x = 4.19$ MHz)	Square wave output frequency ($f_x = 4.19$ MHz)
6	5	4	3	2		
0	0	0	0	1	$256 (N+1)/f_x = 122 \mu s - 15.6 ms$	$f_x/256 (N+1) = 64 Hz - 8 kHz$
0	0	0	1	0	$128 (N+1)/f_x = 61.0 \mu s - 7.81 ms$	$f_x/128 (N+1) = 128 Hz - 16 kHz$
0	0	1	0	0	$64 (N+1)/f_x = 30.5 \mu s - 3.91 ms$	$f_x/64 (N+1) = 256 Hz - 32 kHz$
0	1	0	0	0	$32 (N+1)/f_x = 15.3 \mu s - 1.95 ms$	$f_x/32 (N+1) = 512 Hz - 65 kHz$
1	0	0	0	0	$16 (N+1)/f_x = 7.63 \mu s - 977 \mu s$	$f_x/16 (N+1) = 1024 Hz - 131 kHz$

- Cautions 1.** A value other than the above cannot be set in MODL. Bits 0, 1, and 7 must be set to 0.
2. N is the set value of MODH. 0 must not be set for N.
 Be sure to set a value from 1 to 255 for N.

(4) Configuration and operation when the timer/pulse generator is used in the PWM pulse generation mode

Fig. 4-34 shows the configuration when the timer/pulse generator is used in the PWM pulse generation mode.

The PWM pulse generation mode is selected by setting TPGM0 to 0. TPGM5 and TPGM7 are set to 1 to enable pulse output. In the PWM mode, the PWM pulse signal can be output on the PPO pin, and IRQTPG can be set at intervals of a fixed time period ($2^{15}/f_x = 5.46 \text{ ms}$ at 6.0 MHz)^{Note 1}.

PWM pulses output by the μPD75238 are active-low and have an accuracy of 14 bits. This pulse signal is applicable for electronic tuning and control of a DC motor when it is integrated by an external low-pass filter and is converted to analog voltage. (See Fig. 4-35.)

The PWM pulse signal is generated by combining the basic period determined by $2^{10}/f_x$ (171 μs at 6.0 MHz)^{Note 2} and the secondary period by $2^{15}/f_x$ (5.46 ms at 6.0 MHz)^{Note 1} so that the time constant of the external low-pass filter can be decreased.

The low-level width of a PWM pulse depends on the 14-bit modulo latch value. The upper 8 bits of the modulo latch are sent from the 8 bits of MODH, and the lower 6 bits of the latch are sent from the upper 6 bits of MODL.

When the PWM pulse signal is converted to analog form, the voltage level of the analog output is obtained as follows:

$$V_{AN} = V_{ref} \times \frac{\text{Value of modulo latch}}{2^{14}}$$

V_{ref} : Reference voltage of external switching circuitry

To prevent an incorrect PWM pulse from being output by unstable modulo latch data being rewritten, the μPD75238 allows correct data to be written in MODH and MODL beforehand with 8-bit manipulation instructions, then in the 14-bit data which is to be transferred to the modulo latch at one time. This transfer operation is referred to as reloading, and it is controlled by TPGM3.

- Cautions**
1. If the modulo register H (MODH) is set to 0, the PWM pulse generator cannot function normally. So be sure to set MODH to a value from 1 to 255.
 2. If the lower 2 bits of the modulo register L (MODL) are read, the read result is unpredictable.
 3. If the modulo latch is changed in a shorter period than the PWM pulse basic period $2^{10}/f_x$ (171 μs at 6.0 MHz)^{Note 2}, PWM pulses do not change.

- Notes**
1. 7.81 ms at 4.19 MHz
 2. 244 μs at 4.19 MHz

(5) Static output to the PPO pin

When pulse output is unnecessary, the PPO pin can be used as normal static output. In this case, the output data is set in TPGM4 with TPGM5 being set to 0 and TPGM7 to 1.

Fig. 4-34 Block Diagram of the Timer/Pulse Generator (PWM Pulse Generation Mode)

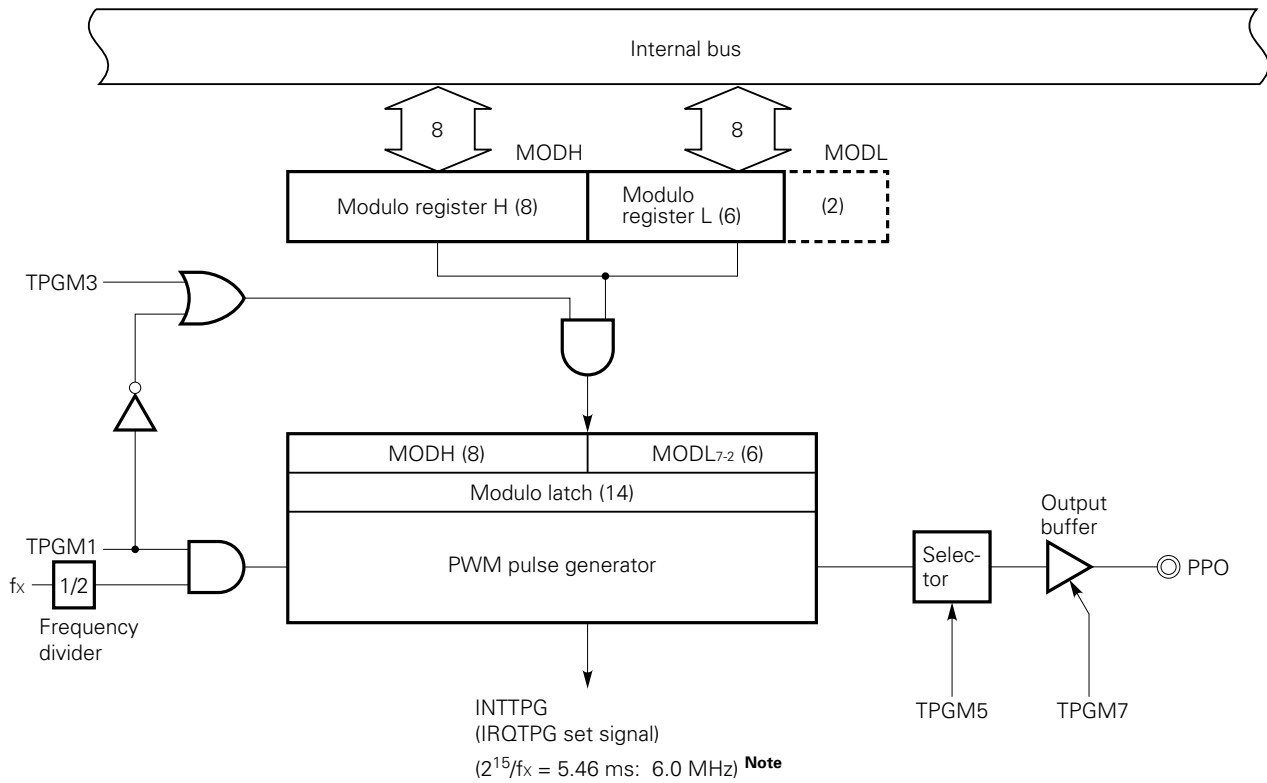

Note 7.81 ms at 4.19 MHz

Fig. 4-35 Sample Configuration of D/A Conversion Using μPD75238

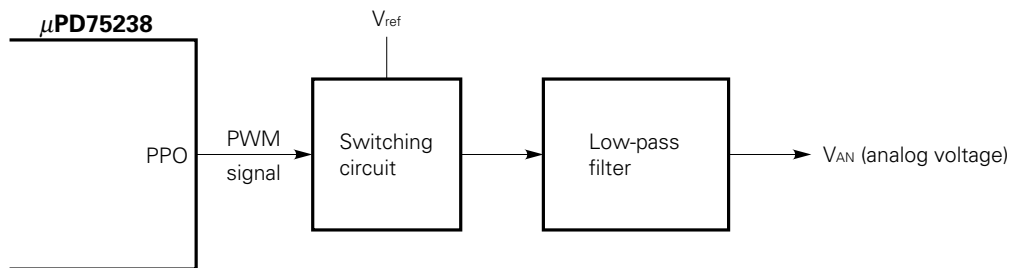

4.8 EVENT COUNTER

(1) Configuration of the event counter

The event counter of the μPD75238 has a noise eliminator. Fig. 4-36 shows the configuration of the counter.

Fig. 4-36 Block Diagram of the Event Counter

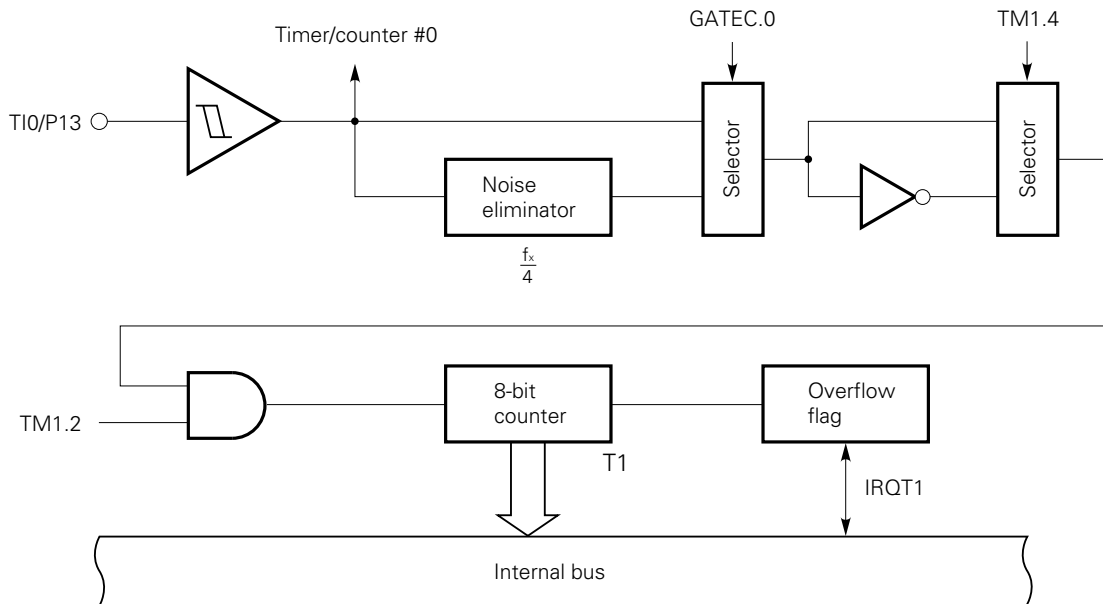

Caution The TI0/P13 pin is an external event pulse input pin shared between timer/event counter #0 and event counter #1.

(2) Event counter functions

The event counter provides the following functions:

- (a) Event counter operation
- (b) Function of reading the state of counting
- (c) Count pulse edge specification
- (d) Noise elimination function

(3) Event counter mode register

The event counter mode register (TM1) is an 8-bit register that controls the event counter. Fig. 4-37 shows the format of the register.

The TM1 is set with an 8-bit memory manipulation instruction. Bit 3 is an event counter start bit, and can be set independently of the other bits. Bit 3 is automatically reset to 0 when the timer starts operation.

Fig. 4-37 Format of the Event Counter Mode Register

Address	7	6	5	4	3	2	1	0	Symbol
FA8H	0	0	0	TM14	TM13	TM12	0	0	TM1

Event count operation enable/disable bit

TM12	0	Disables count operation (count value retained)
	1	Enables count operation

Event count start instruction bit

TM13	When 1 is written, the counter and the IRQ1 flag are cleared. IF TM12 is set to 1, count operation starts.
------	--

Count pulse edge specification

TM14	0	T10 input rising edge
	1	T10 input falling edge

(4) Overflow flag (IRQ1)

The overflow flag is set to 1 when the event counter (IRQ1) overflows. The flag is cleared to 0 by a count operation start instruction.

(5) Event counter control register (GATEC)

This register specifies sampling by sampling clock ($f_x/4$). A noise eliminator eliminates pulses narrower than two sampling clock cycles ($8/f_x$) as noise and accepts pulses wider than as interrupt signals.

Fig. 4-38 shows the format of the GATEC.

Fig. 4-38 Format of the Event Counter Control Register

Address	3	2	1	0	Symbol
FABH	0	0	0	GATEC0	GATEC

0	No sampling
1	Sampling at $f_x/4$

4.9 SERIAL INTERFACE

The μPD75238 has two channels of clock synchronous 8-bit serial interface: Channel 0 and channel 1. Table 4-5 lists the differences between channel 0 and channel 1.

Table 4-5 Differences between Channel 0 and Channel 1

Serial transfer mode, function		Channel 0	Channel 1
3-wire serial I/O	Clock selection	$f_x/2^4$, $f_x/2^3$, TOUT F/F, external clock	$f_x/2^4$, $f_x/2^3$, external clock
	Transfer method	Start bit switchable: MSB/LSB	Start bit: MSB
	Transfer end flag	Serial transfer end interrupt request flag (IROCSI0)	Serial transfer end flag (EOT)
2-wire serial I/O	Available	Not available	
Serial bus interface			

(1) Serial interface (channel 0) functions

The serial interface (channel 0) of the μ PD75238 has following four different modes.

The functions of the four modes are outlined below.

- **Operation halt mode**

This mode is used when serial transfer is not performed. This mode reduces power consumption.

- **Three-wire serial I/O mode**

In this mode, 8-bit data is transferred through three lines: Serial clock ($\overline{\text{SCK0}}$), serial output (SO0), and serial input (SI0).

The three-wire serial I/O mode allows full-duplex transmission, so data transfer can be performed at higher speed.

The user can choose 8-bit data transfer starting with the MSB or LSB, so devices starting with either the MSB or LSB can be connected.

The three-wire serial I/O mode enables connections to be made with the 75X series, 78K series, and many other types of peripheral I/O devices.

- **Two-wire serial I/O mode**

In this mode, 8-bit data is transferred through two lines: Serial clock ($\overline{\text{SCK0}}$) and serial data bus (SB0 or SB1). By controlling output levels on the two lines by software, communication with multiple devices is enabled.

The output levels of $\overline{\text{SCK0}}$ and SB0 (or SB1) can be controlled by software, so the user can match an arbitrary transfer format. This means that a line that has been required for handshaking to connect multiple lines can be eliminated for more efficient I/O port utilization.

- **Serial bus interface (SBI) mode**

In this mode, communication with multiple devices can be performed using two lines: Serial clock ($\overline{\text{SCK0}}$) and serial data bus (SB0 or SB1).

This mode conforms to the NEC serial bus format.

In this mode, the sender can output, on the serial data bus, an address for selecting a device subject to serial communication, commands directed to the remote device, and data. The receiver can identify an address, commands, and data from received data by hardware. This function enables more efficient I/O port utilization as in the case of the two-wire serial I/O mode. In addition, this function can simplify the serial interface control portion of an application program.

(2) Configuration of serial interface (channel 0)

Fig. 4-39 shows the block diagram of the serial interface (channel 0).

Fig. 4-39 Block Diagram of the Serial Interface (Channel 0)

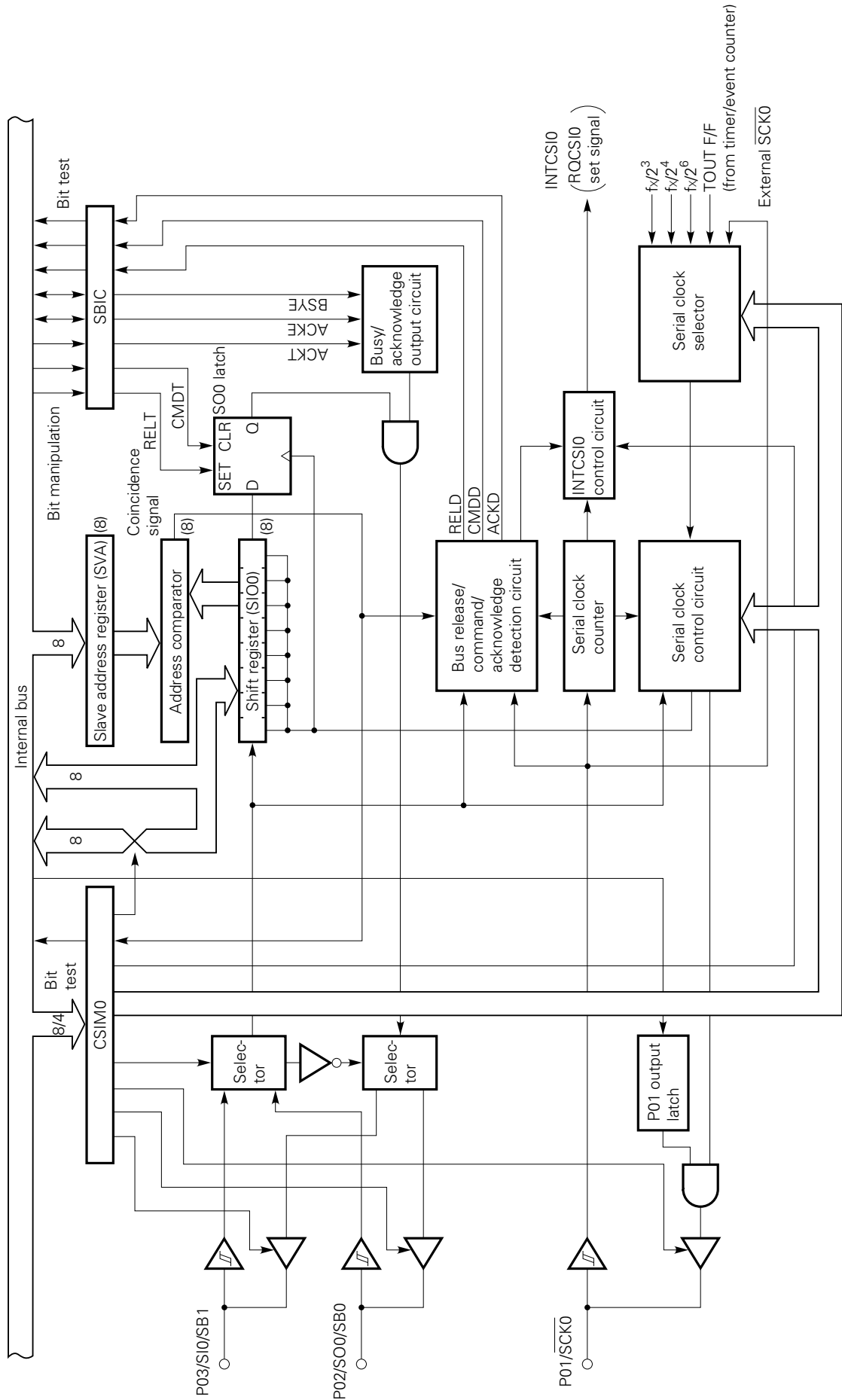

(3) Functions of serial interface (channel 0) registers

(a) Serial operation mode register 0 (CSIM0)

Fig. 4-40 shows the format of serial operation mode register 0 (CSIM0).

CSIM0 is an 8-bit register which specifies a serial interface (channel 0) operation mode, serial clock, wake-up function, and so forth.

CSIM0 is manipulated using an 8-bit memory manipulation instruction. The higher three bits can be manipulated bit by bit. Each bit can be manipulated using its name.

Each bit may or may not allow read and/or write operation. (See Fig. 4-40.) Bit 6 allows bit test operation only; any data written to this bit is invalid.

A RESET input clears all bits to 0.

Fig. 4-40 Format of Serial Operation Mode Register 0 (CSIM0) (1/3)

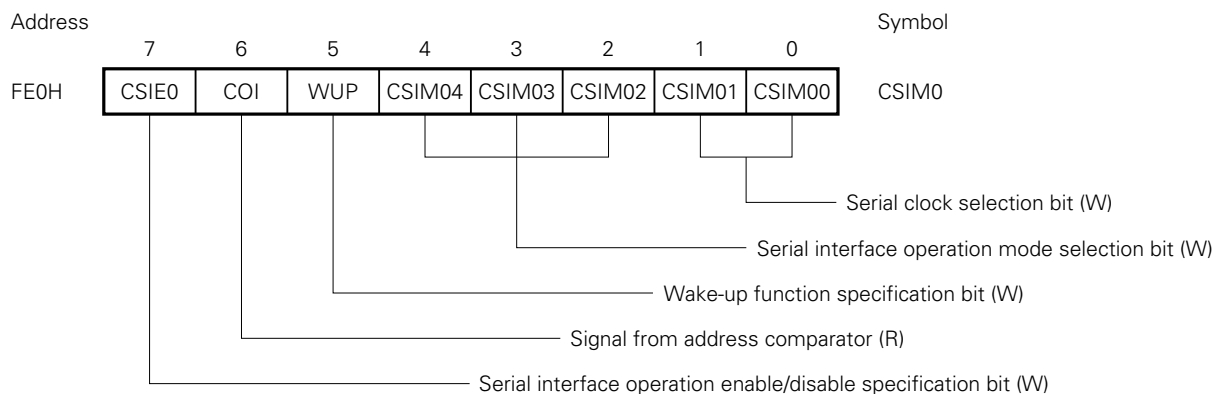

Remark (R) : Read only

(W) : Write only

Fig. 4-40 Format of Serial Operation Mode Register 0 (CSIM0) (2/3)

Serial clock selection bit (W)

CSIM01	CSIM00	Serial clock			$\overline{\text{SCK0}}$ pin mode
		3-wire serial I/O mode	SBI mode	2-wire serial I/O mode	
0	0	External clock applied to $\overline{\text{SCK0}}$ pin			Input
0	1	Time/event counter output (T0)			Output
1	0	$f_x/2^4$ (262 kHz or 375 kHz) ^{Note}		$f_x/2^6$ (65.5 kHz or 93.8 kHz) ^{Note}	
1	1	$f_x/2^3$ (524 kHz or 750 kHz) ^{Note}			

Note The values in parentheses are for $f_x = 4.19$ MHz or 6.0 MHz.

Serial interface operation mode selection bit (W)

CSIM04	CSIM03	CSIM02	Operation mode	Bit sequence for shift register 0	SO0 pin function	SIO pin function
×	0	0	3-wire serial I/O mode	SIO0 ₇₋₀ ↔ XA (Transfer starting with MSB)	SO0/P02 (CMOS output)	SIO/P03 (Input)
		1		SIO0 ₀₋₇ ↔ XA (Transfer starting with LSB)		
0	1	0	SBI mode	SIO0 ₇₋₀ ↔ XA (Transfer starting with MSB)	SB0/P02 (N-ch open-drain input/output)	P03 input
1					P02 input	SB1/P03 (N-ch open-drain input/output)
0	1	1	2-wire serial I/O mode	SIO0 ₇₋₀ ↔ XA (Transfer starting with MSB)	SB0/P02 (N-ch open-drain input/output)	P03 input
1					P02 input	SB1/P03 (N-ch open-drain input/output)

Remark ×: Don't care

Wake-up function specification bit (W)

WUP	0	Sets IRQCSI0 each time serial transfer is completed in each mode.
	1	Used in the SBI mode only to set IRQCSI0 only when an address received after bus release matches the data in the slave address register (wake-up state). SB0/SB1 goes to high-impedance state.

Caution When WUP = 1 is set during $\overline{\text{BUSY}}$ signal output, $\overline{\text{BUSY}}$ is not released. In the SBI mode, the $\overline{\text{BUSY}}$ signal is output until the next falling edge of the serial clock ($\overline{\text{SCK0}}$) appears after release of $\overline{\text{BUSY}}$ is directed. Before setting WUP = 1, be sure to confirm that the SB0 (or SB1) pin is high after releasing $\overline{\text{BUSY}}$.

Fig. 4-40 Format of Serial Operation Mode Register 0 (CSIM0) (3/3)

Signal from address comparator (R)

COI>Note	Condition for being cleared (COI = 0)	Condition for being set (COI = 1)
	When the slave address register (SVA) does not match the data of the shift register	When the slave address register (SVA) matches the data of the shift register

Note COI can be read only before serial transfer is started or after serial transfer is completed. An undefined value may be read during transfer.
COI data written by an 8-bit manipulation instruction is ignored.

Serial interface operation enable/disable specification bit (W)

		Shift register 0 operation	Serial clock counter	IRQCSI0 flag	SO0/SB0, SI0/SB1 pin
CSIE0	0	Shift operation disabled	Cleared	Held	Used only for port 0
	1	Shift operation enabled	Count operation	Can be set.	Used in each mode as well as for port 0

Remarks 1. Each mode can be selected by setting CSIE0, CSIM03, and CSIM02.

CSIE0	CSIM03	CSIM02	Operation mode
0	×	×	Operation halt mode
1	0	×	Three-wire serial I/O mode
1	1	0	SBI mode
1	1	1	Two-wire serial I/O mode

2. The P01/SCK0 pin assumes the following state according to the setting of CSIE0, CSIM01, and CSIM00:

CSIE0	CSIM01	CSIM00	P01/SCK0 pin state
0	0	0	Input port
1	0	0	High impedance
0	0	1	High level output
0	1	0	
0	1	1	
1	0	1	Serial clock output (High level output)
1	1	0	
1	1	1	

Remarks 3. When clearing CSIE0 during serial transfer, use the following procedure:

- ① Disable interrupts by clearing the interrupt enable flag.
- ② Clear CSIE0.
- ③ Clear the interrupt request flag.

Examples 1. $f_x/2^4$ is selected as the serial clock, serial interrupt IRQCSI0, is generated each time serial transfer is completed, and serial transfer is performed in the SBI mode with the SB0 pin used as the serial data bus.

```
SEL    MB15          ; or CLR1 MBE
MOV    XA, #10001010B
MOV    CSIM0, XA     ; CSIM0 ← 10001010B
```

2. Serial transfer dependent on the contents of CSIM0 is enabled.

```
SEL    MB15          ; or CLR1 MBE
SET1   CSIE0
```

(b) Serial bus interface control register (SBIC)

Fig. 4-41 shows the format of the serial bus interface control register (SBIC).

SBIC is an 8-bit register consisting of bits for controlling the serial bus and flags for indicating the states of input data from the serial bus. SBIC is used mainly in the SBI mode.

SBIC is manipulated using a bit manipulation instruction. SBIC cannot be manipulated using a 4-bit or 8-bit memory manipulation instruction.

Each bit may or may not allow read and/or write operation. (See Fig. 4-41.)

A $\overline{\text{RESET}}$ input clears all bits to 0.

Caution Only the following bits can be used in the three-wire and two-wire serial I/O modes:

- **Bus release trigger bit (RELT):** Sets the SO0 latch.
- **Command trigger bit (CMDT):** Clears the SO0 latch.

Fig. 4-41 Format of Serial Bus Interface Control Register (SBIC) (1/3)

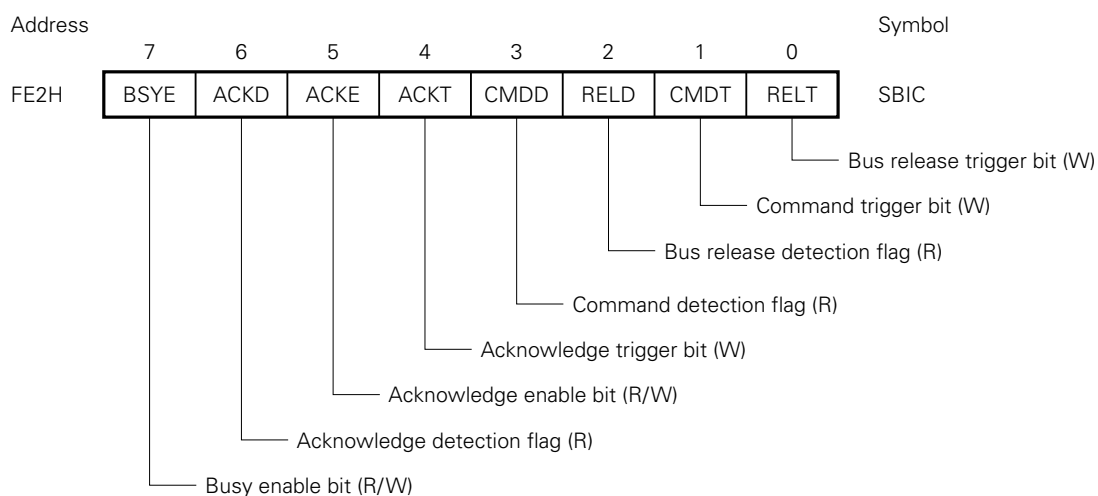

- Remarks**
1. (R) : Read only
 2. (W) : Write only
 3. (R/W): Read/write

Fig. 4-41 Format of Serial Bus Interface Control Register (SBIC) (2/3)

Bus release trigger bit (W)

RELT	Control bit for bus release signal (REL) trigger output. By setting RELT = 1, the SO0 latch is set to 1. Then the RELT bit is automatically cleared to 0.
------	--

Caution Never clear SB0 (or SB1) during serial transfer. Be sure to clear SB0 (or SB1) before or after serial transfer.

Command trigger bit (W)

CMDT	Control bit for command signal (CMD) trigger output. By setting CMDT = 1, the SO0 latch is cleared to 0. Then the CMDT bit is automatically cleared to 0.
------	--

Caution Never clear SB0 (or SB1) during serial transfer. Be sure to clear SB0 (or SB1) before or after serial transfer.

Bus release detection flag (R)

RELD	Condition for being cleared (RELD = 0)	Condition for being set (RELD = 1)
	<ul style="list-style-type: none"> ① The transfer start instruction is executed. ② The RESET signal is entered. ③ CSIE0 = 0 (See Fig. 4-40.) ④ SVA does not match SIO0 when an address is received. 	The bus release signal (REL) is detected.

Command detection flag (R)

CMDD	Condition for being cleared (CMDD = 0)	Condition for being set (CMDD = 1)
	<ul style="list-style-type: none"> ① The transfer start instruction is executed. ② The bus release signal (REL) is detected. ③ The RESET signal is entered. ④ CSIE0 = 0 (See Fig. 4-40.) 	The command signal (CMD) is detected.

Acknowledge trigger bit (W)

ACKT	When set after transfer, \overline{ACK} is output in phase with the next $\overline{SCK0}$. After \overline{ACK} signal output, this bit is automatically cleared to 0.
------	--

- Cautions**
1. Never set ACKT before or during serial transfer.
 2. ACKT cannot be cleared by software.
 3. Before setting ACKT, set ACEK = 0.

Acknowledge enable bit (R/W)

ACEK	0	Disables automatic output of the acknowledge signal (\overline{ACK}). (Output by ACKT is possible.)	
	1	When set before transfer	\overline{ACK} is output in phase with the 9th clock of $\overline{SCK0}$.
		When set after transfer	\overline{ACK} is output in phase with $\overline{SCK0}$ immediately following set instruction execution.

Fig. 4-41 Format of Serial Bus Interface Control Register (SBIC) (3/3)

Acknowledge detection flag (R)

ACKD	Condition for being cleared (ACKD = 0)	Condition for being set (ACKD = 1)
	① The transfer start instruction is executed. ② The RESET signal is entered.	The acknowledge signal (\overline{ACK}) is detected (in phase with the rising edge of SCK0).

Busy enable bit (R/W)

BSYE	0	① The busy signal is automatically disabled. ② Busy signal output is stopped in phase with the falling edge of SCK0 immediately after clear instruction execution.
	1	The busy signal is output after the acknowledge signal in phase with the falling edge of SCK0.

Examples 1. A command signal is output.

```
SEL MB15 ; or CLR1 MBE
SET1 CMDT
```

2. RELD and CMDD are tested to identify the types of received data and the types of processing accordingly.

By setting WUP = 1, this interrupt routine is processed only when an address match is found.

```
SEL MB15
SKF RELD ; RELD test
BR !ADRS
SKT CMDD ; CMDD test
BR !DATA
```

```
CMD : ..... ; Command analysis
DATA : ..... ; Data processing
ADRS : ..... ; Address decode
```

(c) Shift register (SIO0)

Fig. 4-42 shows the configuration of peripheral hardware of shift register 0. SIO0 is an 8-bit register which performs parallel-serial conversion and serial transfer (shift) operation in phase with the serial clock.

Serial transfer is started by writing data to SIO0.

In send operation, data written to SIO0 is output on the serial output (SO0) or serial data bus (SB0/SB1). In receive operation, data is read from the serial input (SI0) or SB0/SB1 into SIO0.

Data can be read from or written to SIO0 by using an 8-bit manipulation instruction.

When the RESET signal is entered during operation, the value of SIO0 is undefined. When the RESET signal is entered in the standby mode, the value of SIO0 is preserved.

Shift operation is stopped after 8-bit send or receive operation is completed.

Fig. 4-42 Peripheral Hardware of Shift Register 0

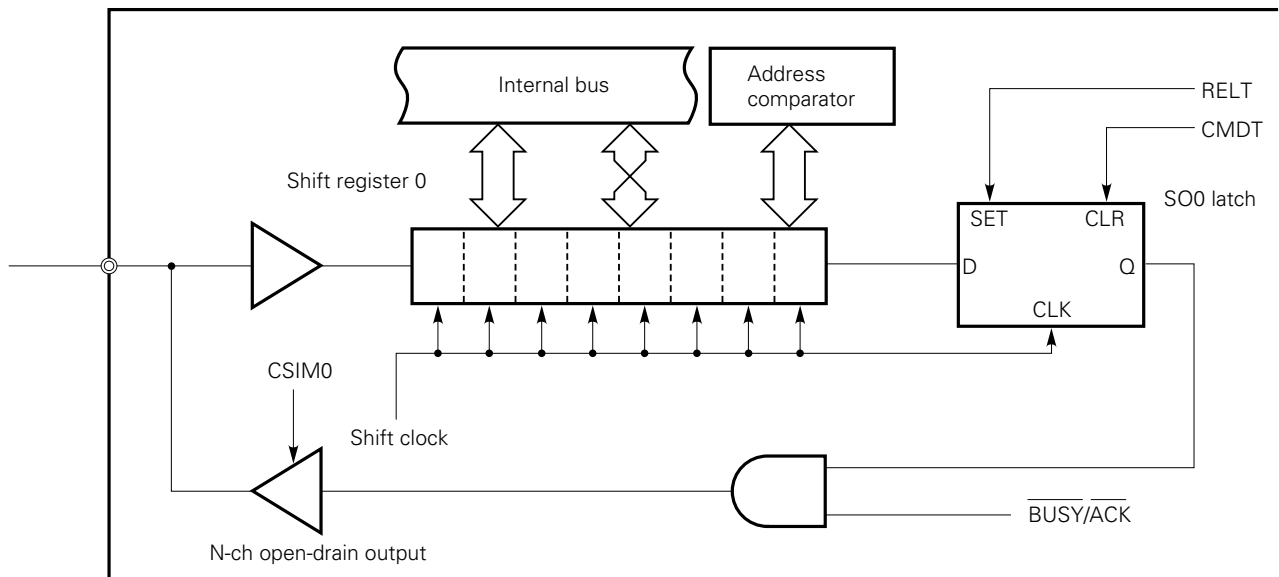

The timing for reading SIO0 and start of serial transfer (writing to SIO0) is as follows:

- When the serial interface operation enable/disable bit (CSIE0) = 1. However, the case where CSIE0 is set to 1 after data is written to the shift register is excluded.
- When the serial clock is masked after 8-bit serial transfer
- SCK0 is high.

When reading from or writing to SIO0, make sure that SCK0 is high.

In the two-wire serial I/O mode and SBI mode, the pins specified for the data bus are used for both input and output. Because the configuration of output pins is N-ch open-drain, write FFH in SIO0 for devices that are to receive data.

(d) Slave address register (SVA)

The slave address register (SVA) has the two functions described below.

SVA is manipulated using an 8-bit manipulation instruction. SVA allows only write operation.

When a $\overline{\text{RESET}}$ is entered, the value of SVA is undefined. However, the value of SVA is preserved when the $\overline{\text{RESET}}$ is entered in the standby mode.

• Slave address detection**[In the SBI mode]**

SVA is used when the μ PD75238 is connected as a slave device to the serial bus. SVA is an 8-bit register for a slave to set its slave address (number assigned to it). The master outputs a slave address to the connected slaves to select a particular slave. Two data values (a slave address output from the master and the value of SVA) are compared with each other by the address comparator. If a match is found, the slave is selected.

At this time, bit 6 (COI) of serial operation mode register 0 (CSIM0) is set to 1.

Cautions 1. Slave selection or nonselection state is detected by detecting a match for a slave address received after bus release (in the state of RELD = 1).

For this match detection, an address match interrupt (IRQCSI0) generated when WUP is set to 1 is usually used. So detect selection/nonselection state by slave address when WUP is set to 1.

2. When detecting selection/nonselection state without using an interrupt when WUP is 0, do not use the address match detection method. Instead, use transfer of commands set in advance in a program.

• Error detection**[In the two-wire serial I/O mode or SBI mode]**

SVA detects an error in either of the following cases:

- When addresses, commands, or data is transferred with the μ PD75238 operating as the master
- When data is transferred with the μ PD75238 operating as a slave

(4) Signals

Table 4-6 lists signals. Fig. 4-43 to 4-48 show operations of signals and flags.

Table 4-6 Various Signals Used in the SBI Mode (1/2)

Signal name	Output device	Definition	Timing chart	Condition for output	Flag operation	Meaning of signal
Bus release signal (REL)	Master	Rising edge of SB0/SB1 when $\overline{SCK0} = 1$		<ul style="list-style-type: none"> • RELT is set. 	<ul style="list-style-type: none"> • RELD is set. • CMDD is cleared. 	Indicates that CMD signal follows and data sent is address data.
Command signal (CMD)	Master	Falling edge of SB0/SB1 when $\overline{SCK0} = 1$		<ul style="list-style-type: none"> • CMDT is set. 	<ul style="list-style-type: none"> • CMDD is set. 	i) Data sent after REL signal output is address. ii) Data sent, with REL signal not being output, is command.
Acknowledge signal (ACK)	Master/slave	Low level signal output on SB0/SB1 during one $\overline{SCK0}$ clock cycle after serial receive operation is completed	[Synchronous busy signal output]	# ACKE = 1 \$ ACKT is set.	<ul style="list-style-type: none"> • ACKD is set. 	Indicates completion of receive operation.
Busy signal (BUSY)	Slave	[Synchronous busy signal] Low level signal output on SB0/SB1 after acknowledge signal		<ul style="list-style-type: none"> • BSYE = 1 	-	Indicates that serial receive operation is disabled because processing is in progress.
Ready signal (READY)	Slave	High level signal output on SB0/SB1 before serial transfer is started or after serial transfer is completed		# BSYE = 0 \$ Execution of instruction to write data to SIO0 (direction to start transfer)	-	Indicates that serial receive operation is enabled.

Table 4-6 Various Signals Used in the SBI Mode (2/2)

Signal name	Output device	Definition	Timing chart	Condition for output	Flag operation	Meaning of signal
Serial clock (SCK0)	Master	Synchronous clock for outputting address/command/data, ACK signal, synchronous BUSY signal, and so on. Address/command/data is output during first 8 clock cycles.		Execution of instruction to write data to SIO0 when CSIE0 = 1 (direction to start serial transfer) ^{Note 2}	IRQCSI0 is set (on rising edge of ninth clock) ^{Note 1}	Timing of signal output on serial data bus
Address (A7 - A0)	Master	8-bit data transferred in phase with SCK0 after REL signal and CMD signal output				Address of slave device on serial bus
Command (C7 - C0)	Master	8-bit data transferred in phase with SCK0 after only CMD signal is output, with REL signal not being output				Directions and messages to slave device
Data (D7 - D0)	Master/slave	8-bit data transferred in phase with SCK0, with neither REL signal nor CMD signal being output				Value processed by slave or master device

Notes 1. When WUP = 0, IRQCSI0 is always set on the ninth rising edge of SCK0.

When WUP = 1, IRQCSI0 is set on the ninth rising edge of SCK0 only if a received address matches the value of the slave address register (SVA).

2. If the BUSY state is present, data transfer is started after the READY state is set.

Fig. 4-43 Operations of RELT, CMDT, RELD, and CMDD (Master)

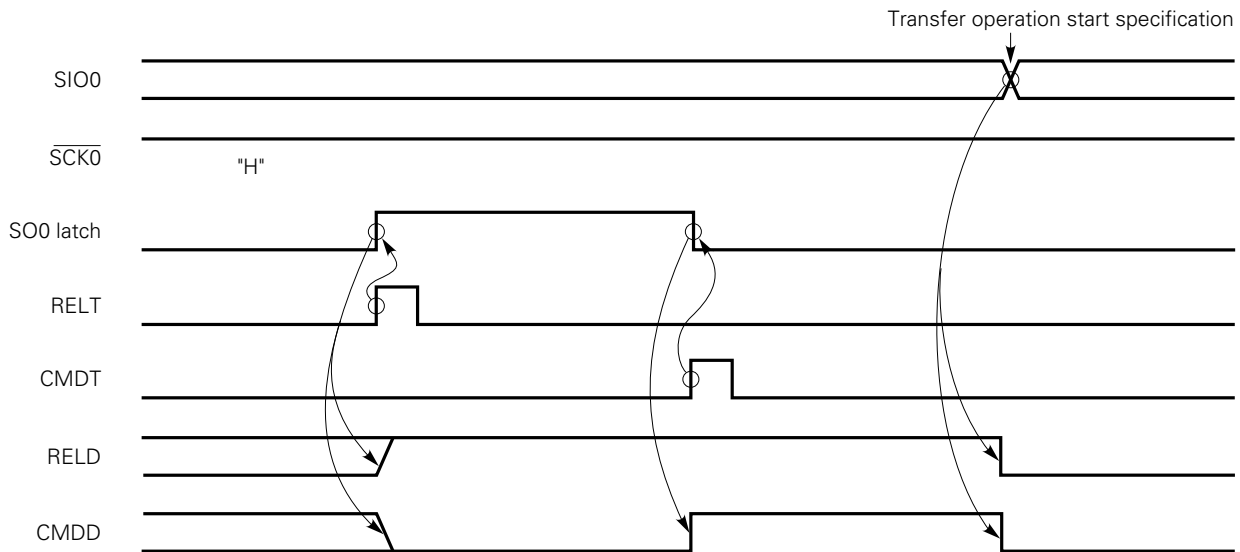

Fig. 4-44 Operations of RELT, CMDT, RELD, and CMDD (Slave)

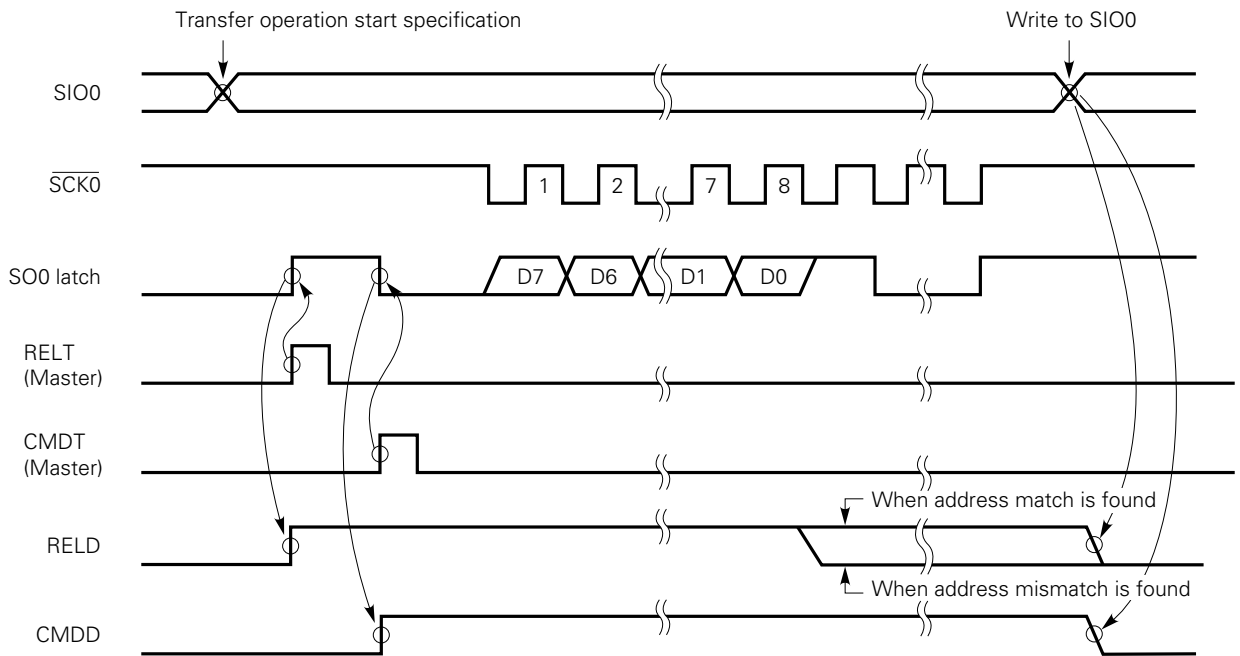
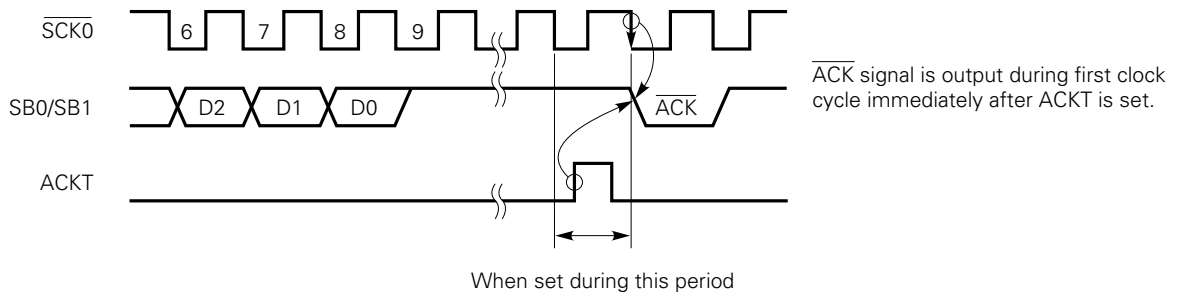

Fig. 4-45 Operation of ACKT

Set after transfer completion.



Caution Do not set the ACKT until the transfer is completed

Fig. 4-46 Operation of ACKE

(a) When ACKE = 1 at time of transfer operation completion

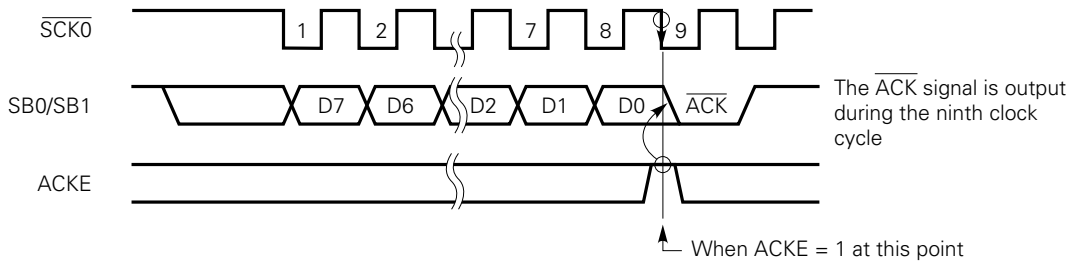

(b) When ACKE is set after transfer operation completion

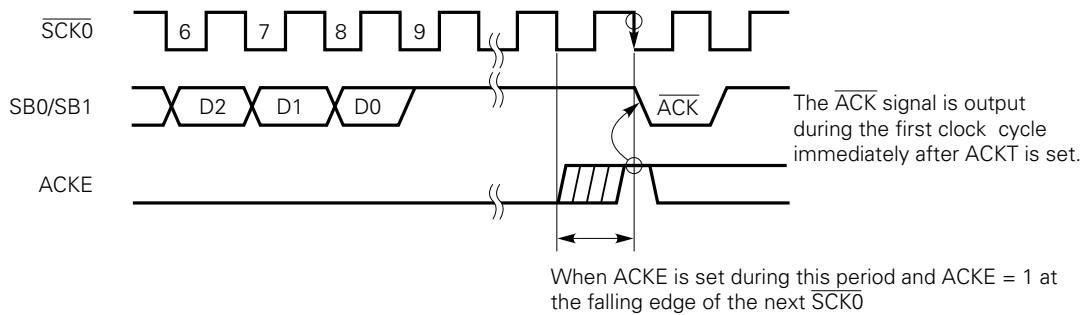

(c) When ACKE = 0 at time of transfer operation completion

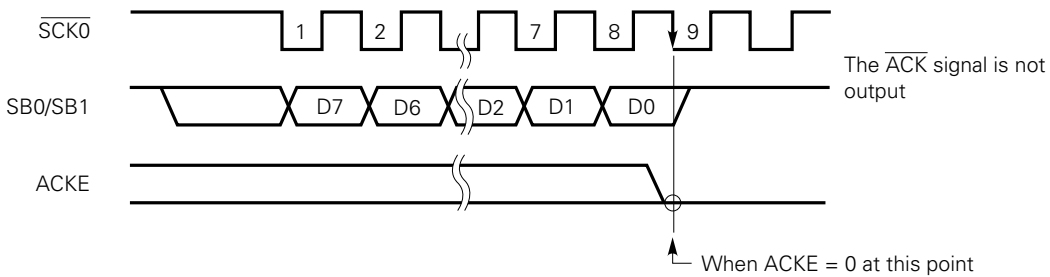

(d) When ACKE = 1 period is too short

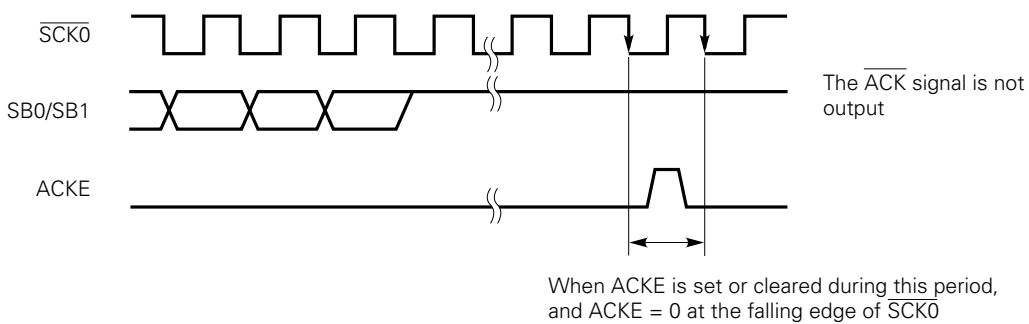
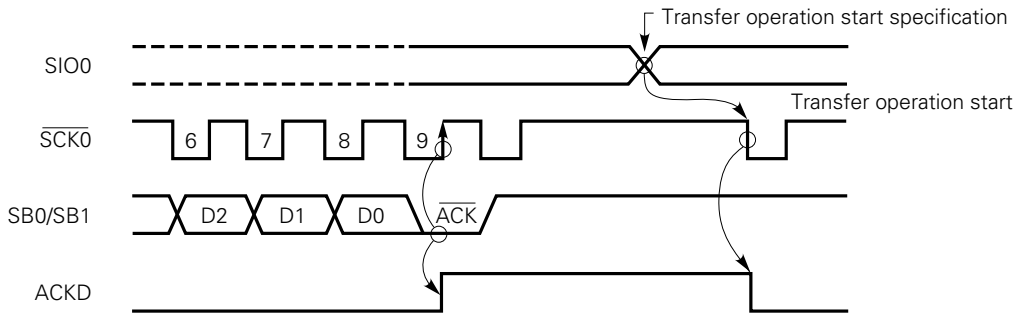
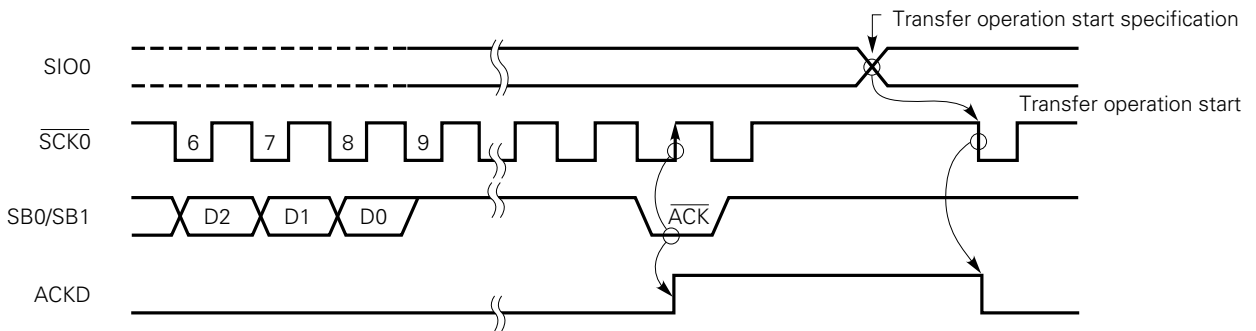

Fig. 4-47 Operation of ACKD

(a) When $\overline{\text{ACK}}$ signal is output during ninth $\overline{\text{SCK0}}$ clock



(b) When $\overline{\text{ACK}}$ signal is output after ninth $\overline{\text{SCK0}}$ clock



(c) Clear timing for case where start of transfer is directed during $\overline{\text{BUSY}}$

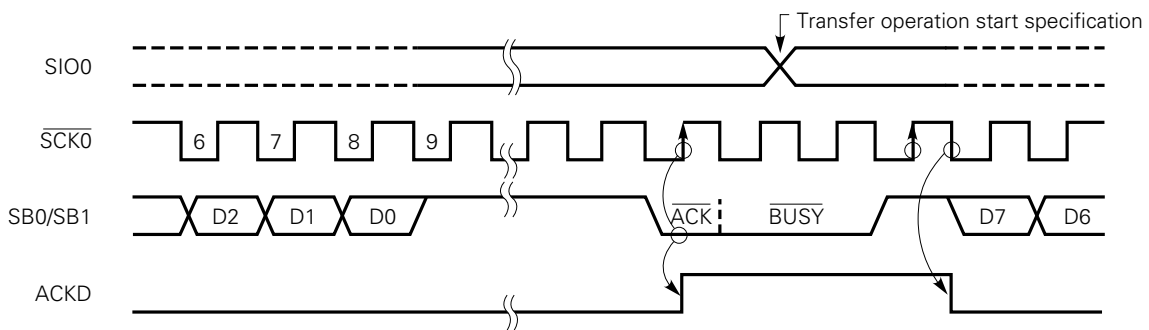
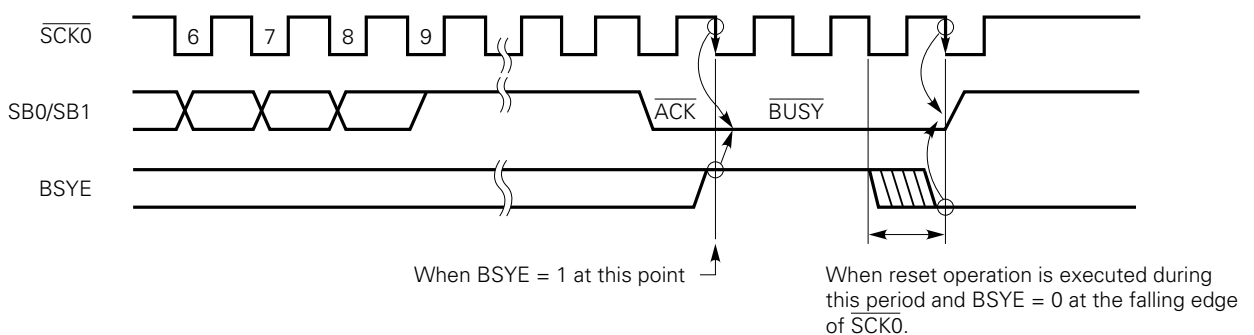

Fig. 4-48 Operation of BSYE



(5) Serial interface (channel 0) operation

(a) Operation halt mode

The operation halt mode is used when serial transfer is not performed. This mode reduces power consumption.

The shift register 0 does not perform shift operation in this mode, so the shift register can be used as a normal 8-bit register.

A $\overline{\text{RESET}}$ input sets the operation halt mode. The P02/SO0/SB0 pin and P03/SI0/SB1 pin function as input-only port pins. The P01/ $\overline{\text{SCK0}}$ pin can be used as an input port pin by setting the serial operation mode register 0.

(b) Three-wire serial I/O mode operations

The three-wire serial I/O mode is compatible with other modes used in the 75X series and 78K series. Communication is performed using three lines: Serial clock ($\overline{\text{SCK0}}$), serial output (SO0), and serial input (SI0).

(i) Communication operation

The three-wire serial I/O mode transfers data, with eight bits as one block. Data is transferred bit by bit in phase with the serial clock.

The shift register performs shift operation on the falling edge of the serial clock ($\overline{\text{SCK0}}$). Send data is latched on the SO0 latch, and is output on the SO0 pin. Receive data applied to the SI0 pin is latched in the shift register 0 on the rising edge of $\overline{\text{SCK0}}$.

When eight bits have been transferred, shift register 0 operation automatically terminates setting the interrupt request flag (IRQCSI0).

Fig. 4-49 Timing of Three-Wire Serial I/O Mode

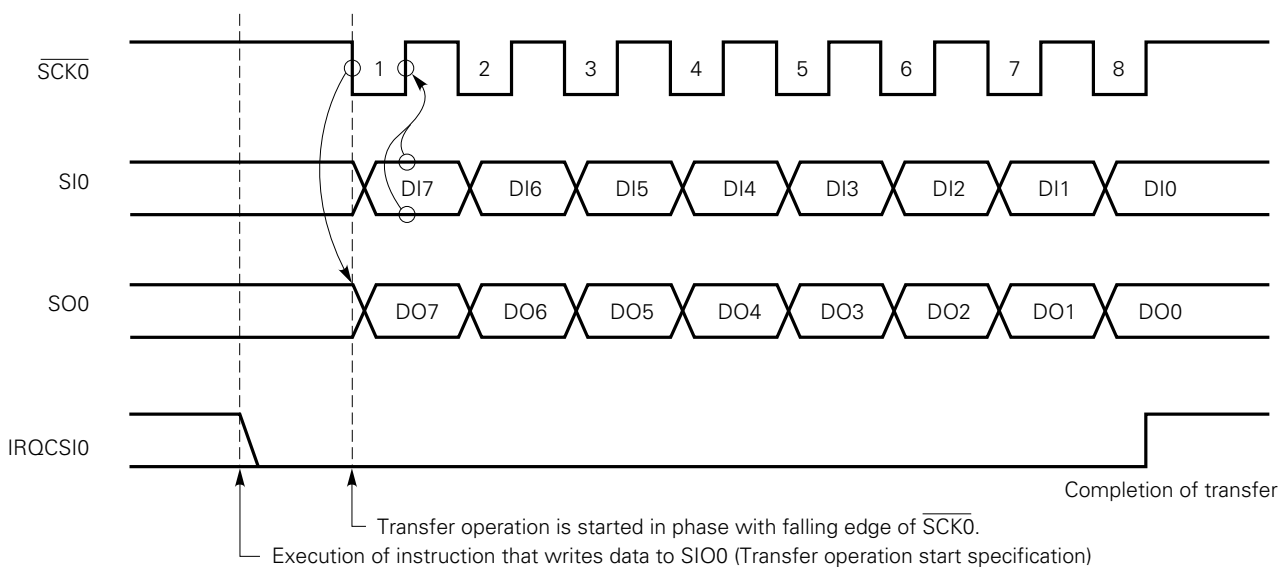

The SO0 pin becomes a CMOS output and outputs the state of the SO0 latch. So the output state of the SO0 pin can be manipulated by setting the RELT bit and CMDT bit.

However, this manipulation must not be performed during serial transfer operation.

The output state of the $\overline{\text{SCK0}}$ pin can be controlled by manipulating the P01 output latch in the output mode (internal system clock mode). (See (7) in Section 4.9.)

(ii) **Switching between MSB and LSB as the first transfer bit**

The three-wire serial I/O mode has a function that can switch between the MSB and LSB as the first bit of transfer.

Fig. 4-50 shows the configuration of shift register 0 (SIO0) and internal bus. As shown in Fig. 4-50, read or write operation can be performed by switching between the MSB and LSB.

This switching can be specified using bit 2 of serial operation mode register 0 (CSIM0).

Fig. 4-50 Transfer Bit Switching Circuit

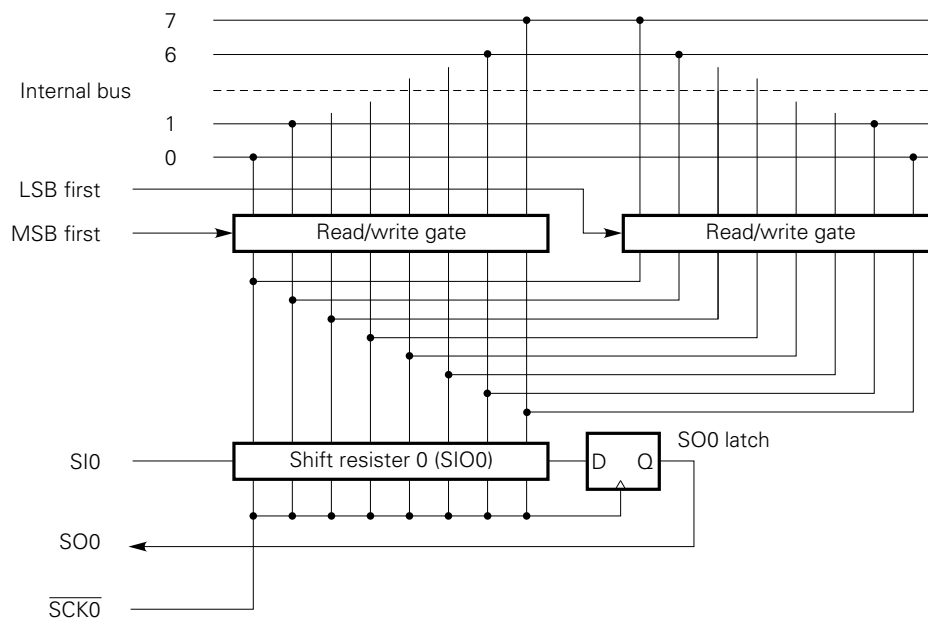

The first bit is switched by changing the order of data bits written to shift register 0 (SIO0). The shift operation order of SIO0 is always the same.

Accordingly, the first bit must be switched between the MSB and LSB before writing data to the shift register 0.

(c) **Two-wire serial I/O mode**

The two-wire serial I/O mode can be made compatible with any communication format by programming. In this mode, communication is basically performed using two lines: Serial clock ($\overline{SCK0}$) and serial data input/output (SB0 or SB1).

(i) **Communication operation**

The two-wire serial I/O mode transfers data, with eight bits as one block. Data is transferred bit by bit in phase with the serial clock.

The shift register 0 performs shift operation on the falling edge of the serial clock ($\overline{SCK0}$). Send data is latched on the SO0 latch, and is output on the SB0/P02 pin or SB1/P03 pin starting with the MSB. Receive data applied to the SB0 pin or SB1 pin is latched in the shift register 0 on the rising edge of $\overline{SCK0}$.

When eight bits have been transferred, shift register 0 operation automatically terminates setting the interrupt request flag (IRQCSI0).

Fig. 4-51 Timing of Two-Wire Serial I/O Mode

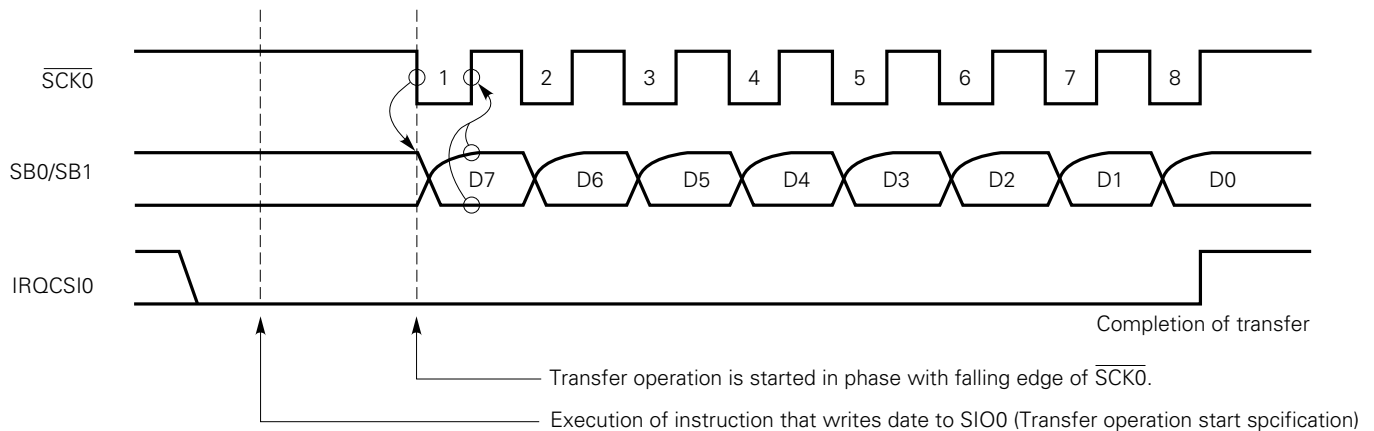

The SB0 or SB1 pin becomes an N-ch open-drain I/O when specified as the serial data bus, so the voltage level on that pin must be pulled up externally.

The state of the SO0 latch is output on the SB0 or SB1 pin, so the SB0 or SB1 pin output states can be controlled by setting the RELT or CMDT bit.

However, this operation must not be performed during serial transfer operation.

The output state of the $\overline{SCK0}$ pin can be controlled by manipulating the P01 output latch in the output mode (internal system clock mode). (See (7) in Section 4.9.)

(d) SBI mode operation

The SBI (serial bus interface) is a high-speed serial interface that conforms to the NEC serial bus format.

To allow communication with multiple devices on a single-master and high-speed serial bus using two signal lines, the SBI has a bus configuration function added to the clock synchronous serial I/O method. So the SBI can reduce ports and wires on boards when multiple microcomputers and peripheral ICs are used to configure a serial bus.

Fig. 4-52 is an example of the SBI system configuration.

Fig. 4-52 Example of SBI System Configuration

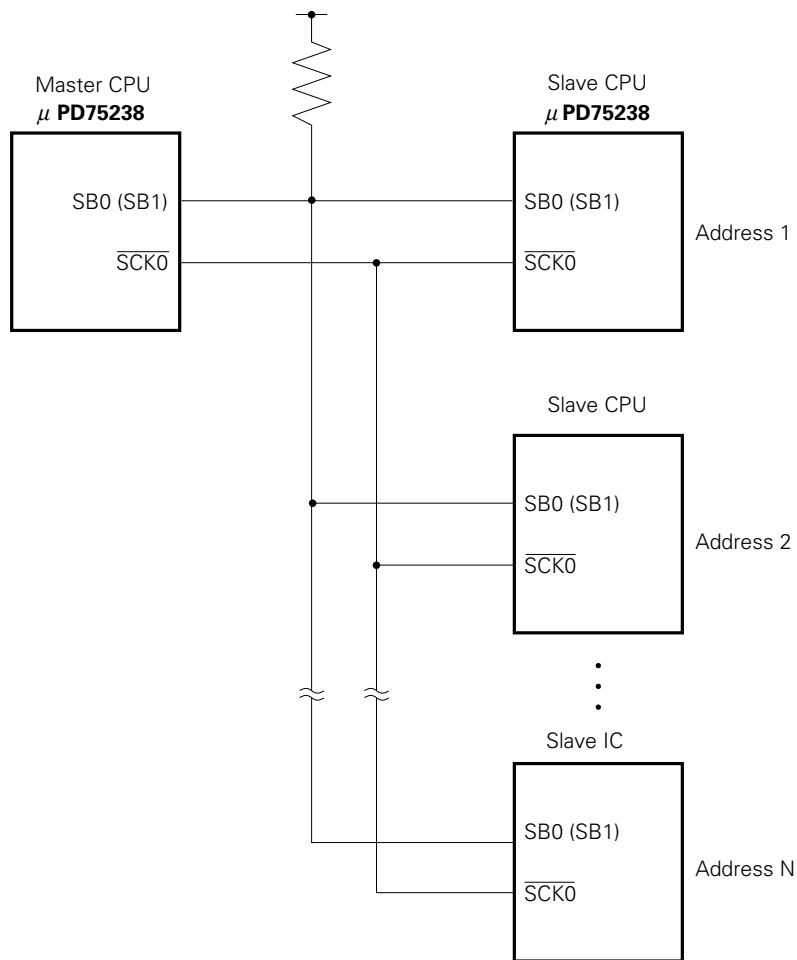

- Cautions**
1. In the SBI mode, the serial data bus pin SB0 (or SB1) is an open-drain output. So the serial data bus line is placed in the wired OR state. A pull-up resistor is required for the serial data bus line.
 2. To switch between the master and slave, a pull-up resistor is required also for the serial clock line (SCK0), because SCK0 input/output switching is performed between the master and slave asynchronously.

(i) **SBI functions**

- Address/command/data identification function
Serial data is classified into three types: Address, command, and data.
- Address-based chip select function
The master selects a chip by address transfer.
- Wake-up function
A slave can easily check address reception (for chip select identification) with the wake-up function. This function can be set or released by software.
When the wake-up function is set, an interrupt (IRQCSI0) is generated when a match address is received. For this reason, in communication with multiple devices, a CPU other than a selected slave can operate independently of serial communication.
- Acknowledge signal (\overline{ACK}) control function
The acknowledge signal, which is used to confirm the reception of serial data, can be controlled.
- Busy signal (\overline{BUSY}) control function
The busy signal, which is used to post the busy state of a slave, can be controlled.

Fig. 4-53 Timing of SBI Transfer

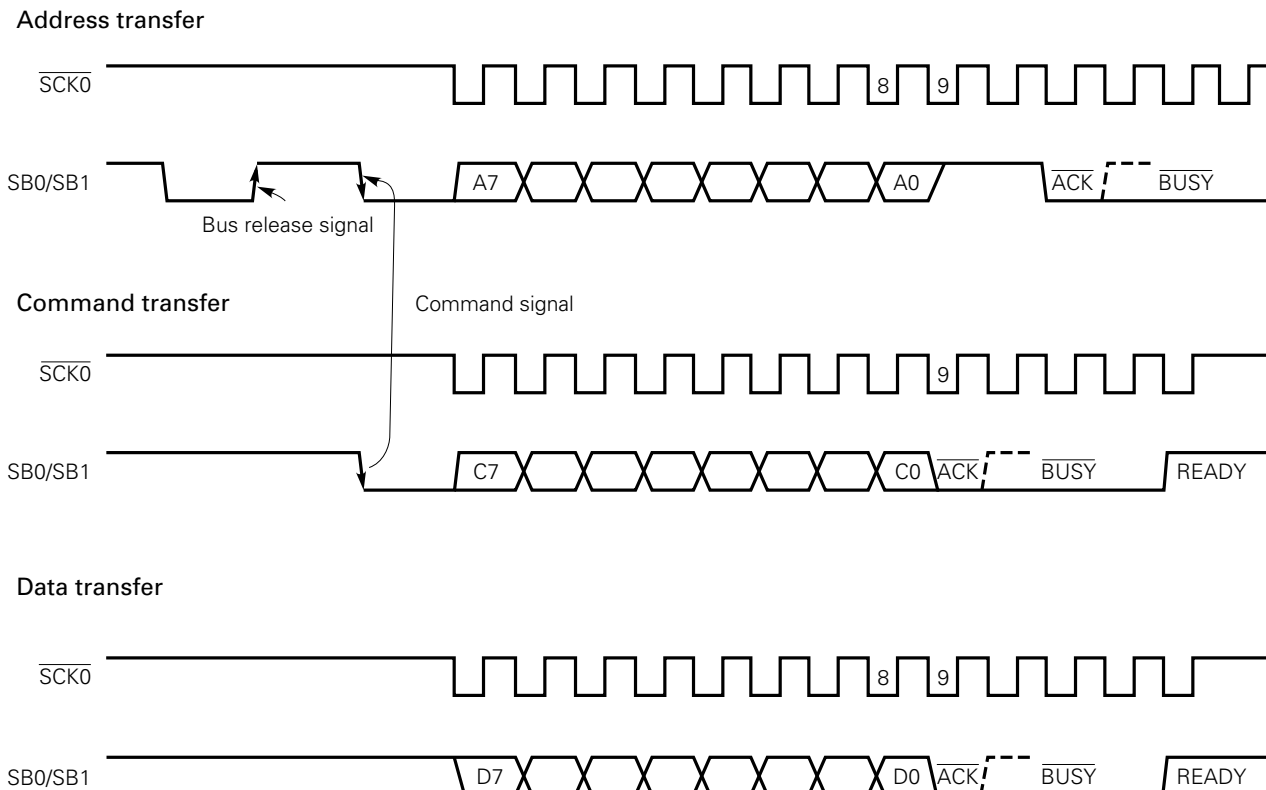

(ii) Communication operation

In the SBI mode, the master usually selects a slave device to communicate with from multiple devices by outputting the address of the slave in the serial bus.

After selecting a device to communicate with, the master exchanges commands and data with the slave device, thus establishing serial communication.

Fig. 4-54 to 4-57 show the timing charts of data communication operations.

In the SBI mode, the shift register 0 performs shift operation on the falling edge of the serial clock ($\overline{SCK0}$). Send data is held on the SO0 latch, and is output on the SB0/P02 or SB1/P03 pin starting with the MSB. Receive data applied to the SB0 (or SB1) pin is latched in the shift register 0 on the rising edge of $\overline{SCK0}$.

Fig. 4-54 Address Transfer Operation from Master Device to Slave Device (WUP = 1)

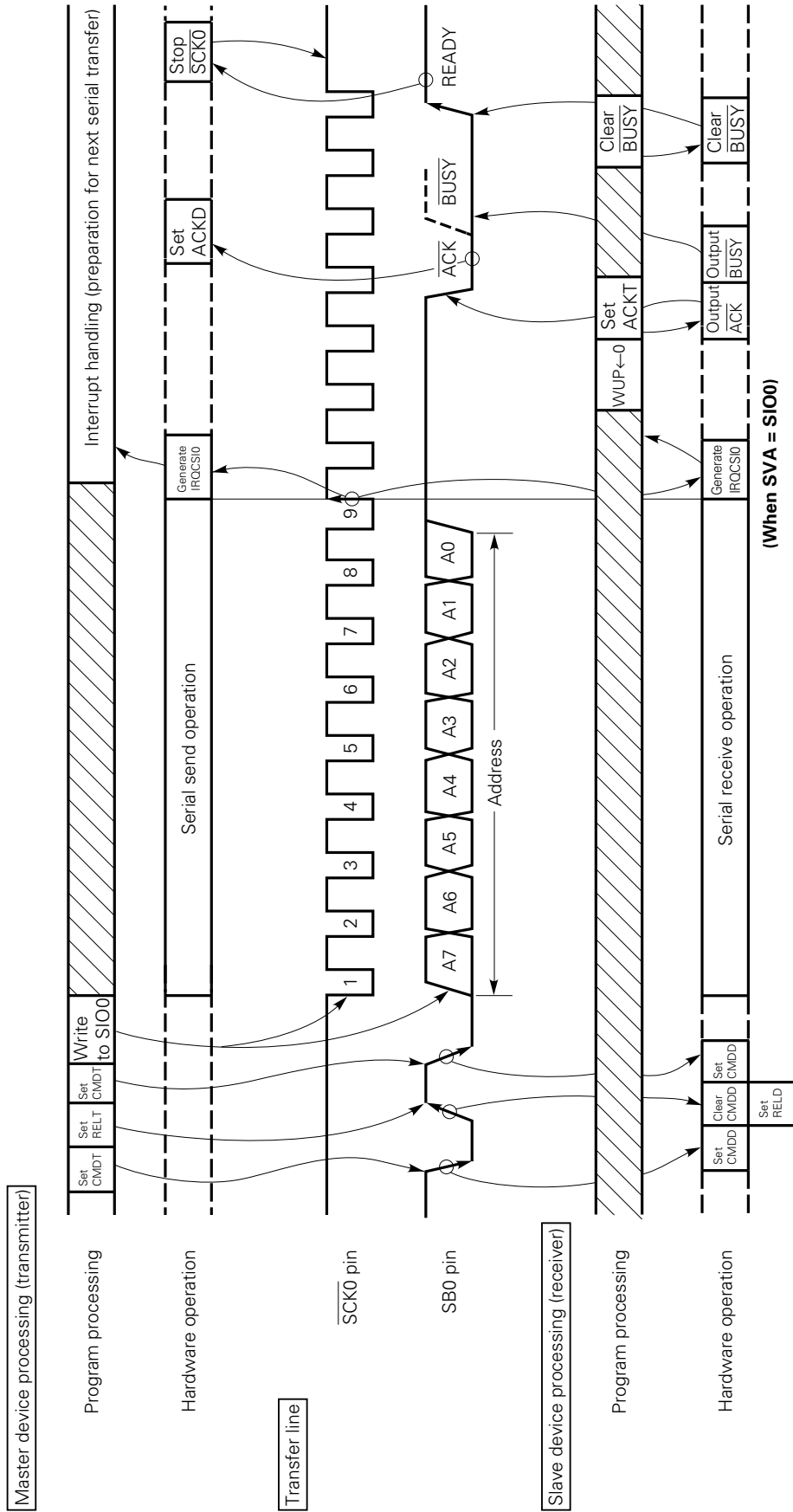

Fig. 4-55 Command Transfer Operation from Master Device to Slave Device

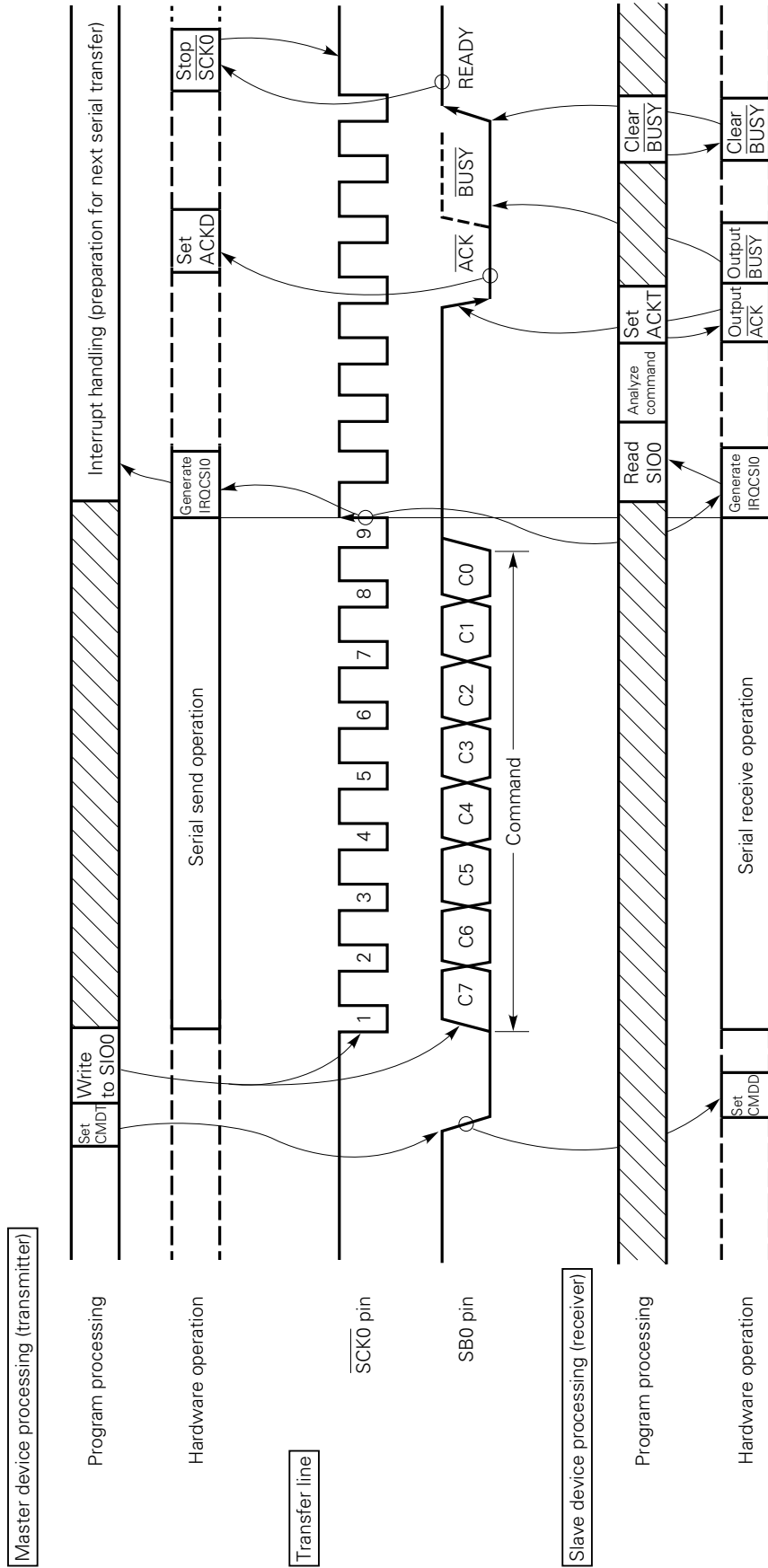

Fig. 4-56 Data Transfer Operation from Master Device to Slave Device

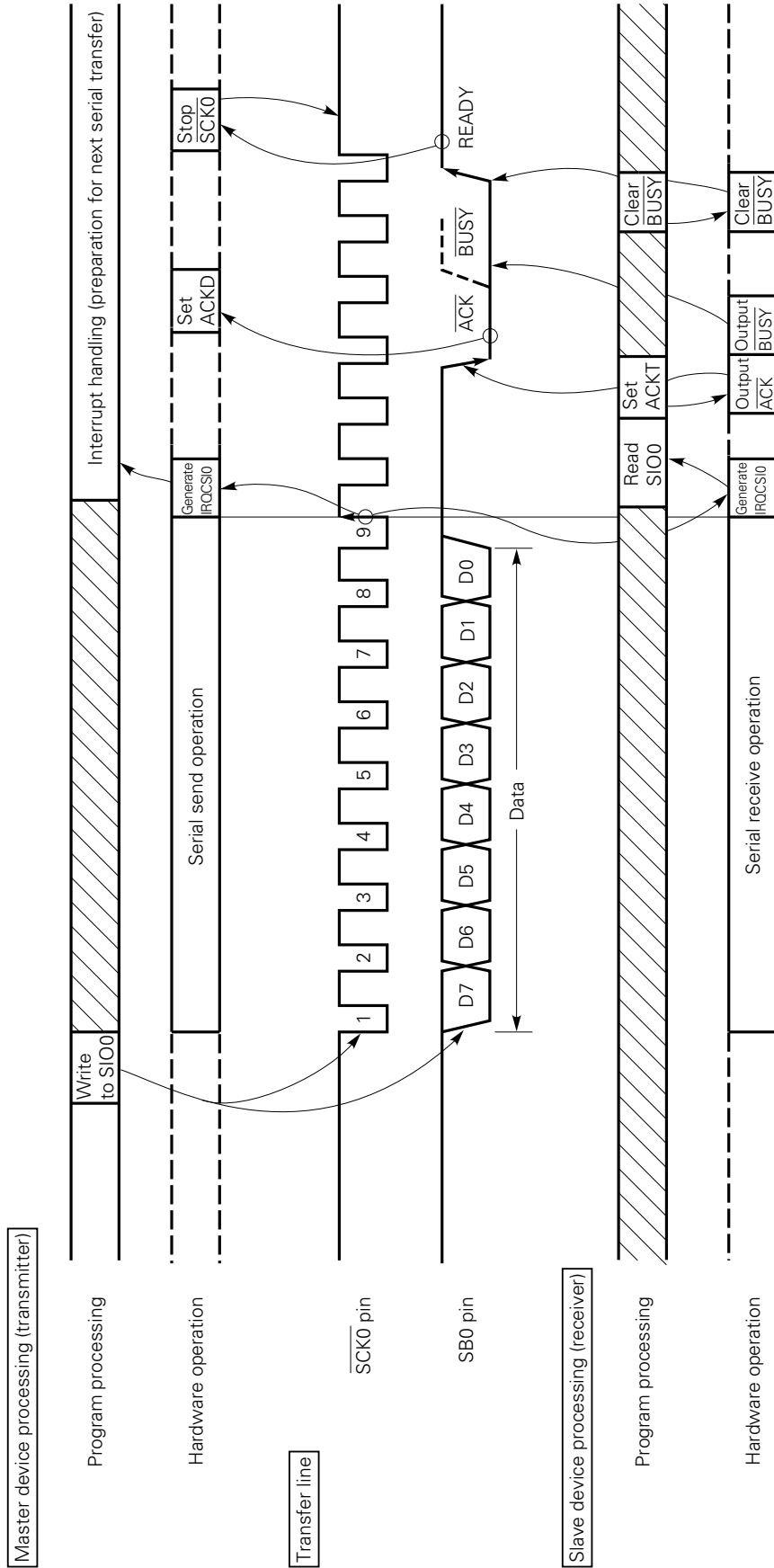
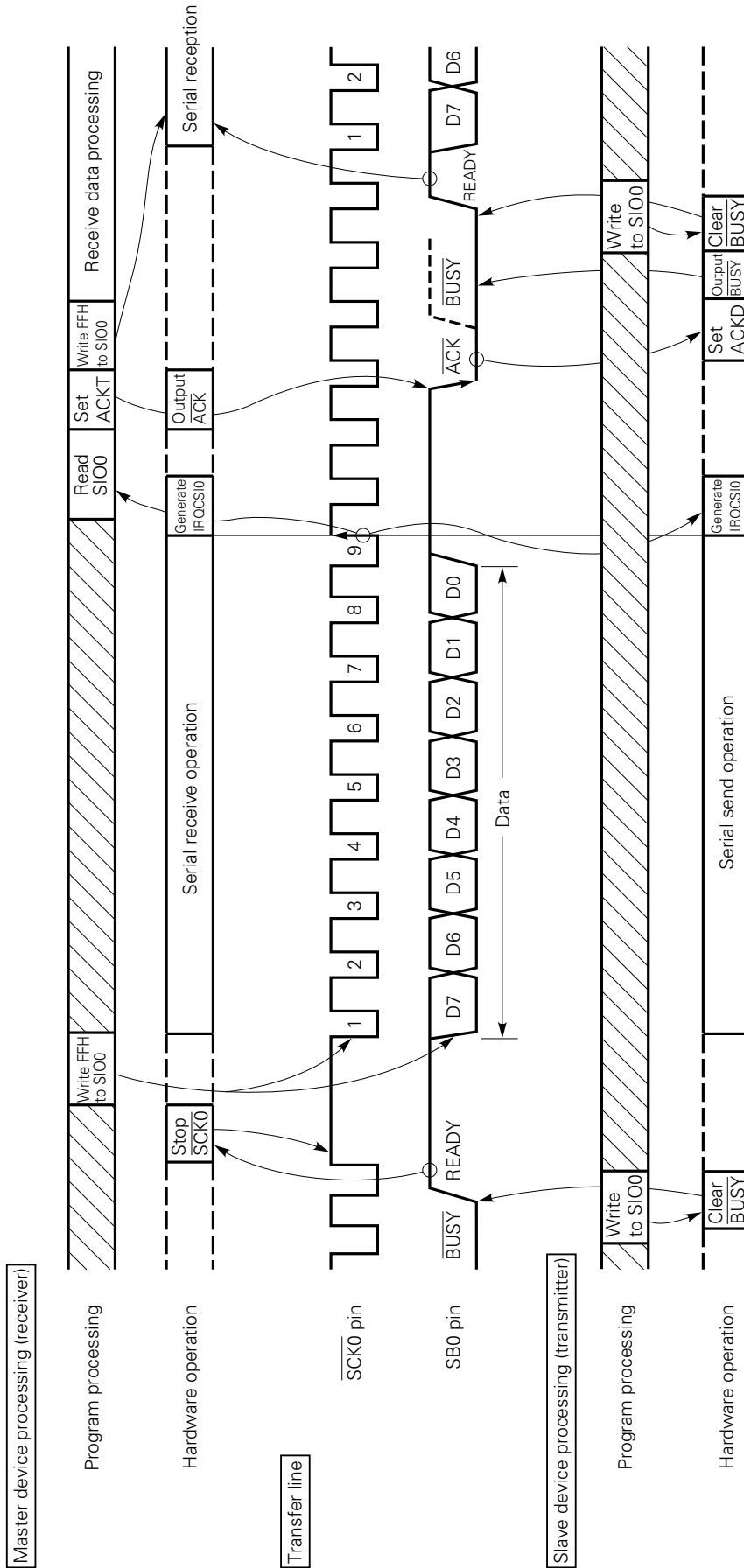

Fig. 4-57 Data Transfer Operation from Master Device to Slave Device ★



(6) Transfer start in each mode

In each of the three-wire serial I/O, two-wire serial I/O, and SBI modes, serial transfer is started by writing transfer data in shift register 0 (SIO0).

However, the following two conditions must be satisfied:

- The serial interface operation enable/disable bit (CSIE0) is set to 1.
- The internal serial clock is not operating after 8-bit serial transfer, or $\overline{\text{SCK0}}$ is high.

Caution Transfer operation cannot be started by setting CSIE0 to 1 after writing data to the shift register 0.

When eight bits have been transferred, serial transfer automatically terminates setting the interrupt request flag (IRQCSI0).

[In the two-wire serial I/O mode]

Caution The N-ch transistor needs to be turned off when data is received. So FFH must be written to SIO0 beforehand.

[In the SBI mode]

Cautions 1. The N-ch transistor needs to be turned off when data is received. So FFH must be written to SIO0 beforehand.

However, when the wake-up function specification bit (WUP) is set to 1, the N-ch transistor is always off. So FFH need not be written to SIO0 beforehand for reception.

2. If data is written to SIO0 when the slave is busy, the data is not lost.

Transfer operation is started when the busy state is released and input to SB0 (or SB1) goes high.

Example When RAM data specified by the HL register is transferred to SIO0, SIO0 data is loaded into the accumulator at the same time, and serial transfer is started.

```
MOV  XA, @HL    ; Extracts send data from RAM
SEL  MB15      ; Or CLR1 MBE
XCH  XA, SIO0  ; Exchanges send data with receive data and starts transfer
```

(7) Manipulation of $\overline{\text{SCK0}}$ pin output

The $\overline{\text{SCK0/P01}}$ pin has a built-in output latch, so that this pin allows static output by software manipulation in addition to normal serial clock output.

The number of $\overline{\text{SCK0}}$ s can be software-set arbitrarily by manipulating the P01 output latch. (The SO0/SB0/SB1 pin is controlled by manipulating the RELT and CMDT bits of SBIC.)

The procedure for manipulating $\overline{\text{SCK0/P01}}$ pin output is explained below.

- ① Set serial operation mode register 0 (CSIM0) ($\overline{\text{SCK0}}$ pin: output mode, serial operation: enabled).
When serial transfer operation is halted, $\overline{\text{SCK0}}$ from the serial clock control circuit is set to 1.
- ② Manipulate the P01 output latch by using a bit manipulation instruction.

Example To output one clock cycle on the $\overline{\text{SCK0/P01}}$ pin by software

```

SEL    MB15          ; or CLR1 MBE
MOV    XA, #10000011B ;  $\overline{\text{SCK0}}$  ( $f_x/2^3$ ), output mode
MOV    CSIM0, XA
CLR1   0FF0H.1      ;  $\overline{\text{SCK0/P01}} \leftarrow 0$ 
SET1   0FF0H.1      ;  $\overline{\text{SCK0/P01}} \leftarrow 1$ 
    
```

Fig. 4-58 $\overline{\text{SCK0/P01}}$ Pin Circuit Configuration

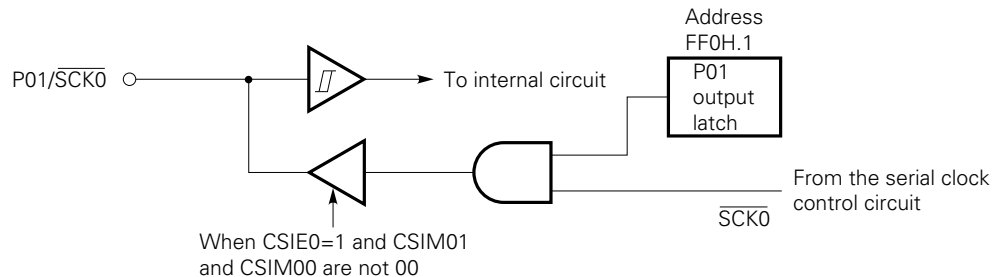

The P01 output latch is mapped to bit 1 of address FF0H. A $\overline{\text{RESET}}$ signal sets the P01 output latch to 1.

- Cautions**
1. During normal serial transfer operation, the P01 output latch must be set to 1.
 2. The P01 output latch cannot be addressed by specifying PORT0.1 (as described below). The address of the latch (0FF0H.1) must be coded in the operand of an instruction directly. However, MBE = 0 (or MBE = 1, MBS = 15) must be specified before the instruction is executed.

CLR1 PORT0.1	}	Not allowed
SET1 PORT0.1		
CLR1 0FF0H.1	}	Allowed
SET1 0FF0H.1		

(8) Serial interface (channel 1) functions

The serial interface (channel 1) of the μ PD75238 has following two modes.
The functions of the two modes are outlined below.

- **Operation halt mode**

This mode is used when serial transfer is not performed. This mode reduces power consumption.

- **Three-wire serial I/O mode**

8-bit data transfer is performed using three lines: Serial clock ($\overline{\text{SCK1}}$), serial output (SO1), and serial input (SI1).

The three-wire serial I/O mode allows full-duplex transmission, so data transfer can be performed at higher speed.

★ Eight-bit data transfer always starts the MSB.

The three-wire serial I/O mode enables connections to be made with the 75X series, 78K series, and many other types of peripheral I/O devices.

(9) Serial interface (channel 1) configuration

Fig. 4-59 shows the block diagram of the serial interface (channel 1).

Fig. 4-59 Block Diagram of the Serial Interface (Channel 1)

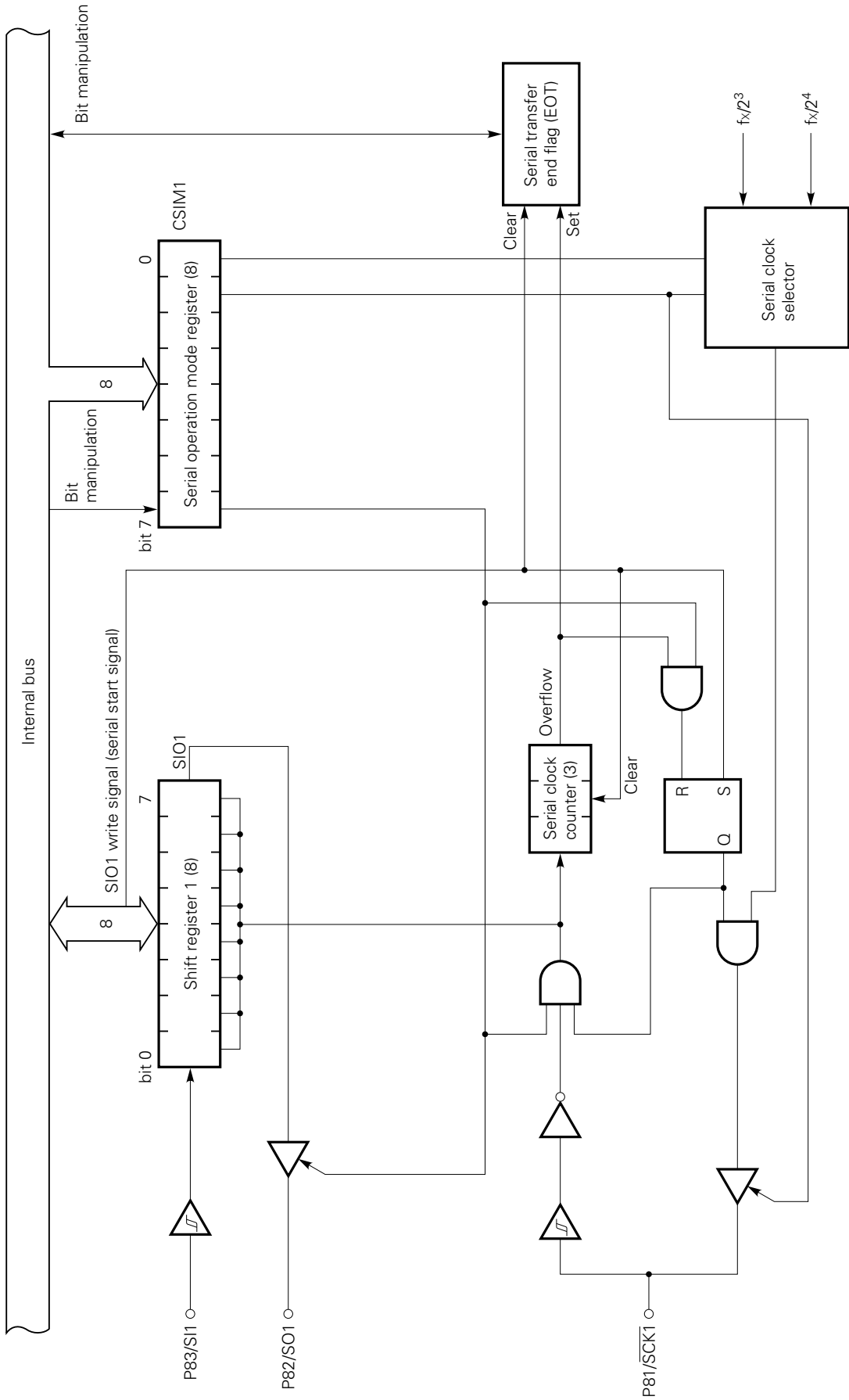

(10) Functions of serial interface (channel 1) registers

(a) Serial operation mode register 1 (CSIM1)

Fig. 4-60 shows the format of serial operation mode register 1 (CSIM1).

CSIM1 is an 8-bit register which specifies a serial interface (channel 1) operation mode and serial clock.

CSIM1 is manipulated using an 8-bit memory manipulation instruction. Only the high-order one bit can be manipulated independently. Each bit can be manipulated using its name.

A RESET input clears all bits to 0.

Fig. 4-60 Format of Serial Operation Mode Register 1

Address	7	6	5	4	3	2	1	0	Symbol
FC8H	CSIE1	0	0	0	0	0	CSIM11	CSIM10	CSIM1

Serial clock selection bit (W)

CSIM11	CSIM10	Serial clock (3-wire serial I/O mode)	SCK1 pin mode
0	0	External clock applied to SCK1 pin	Input
0	1	Not to be set	—
1	0	$f_x/2^4$ (262 kHz or 375 kHz) ^{Note}	Output
1	1	$f_x/2^3$ (524 kHz or 750 kHz) ^{Note}	

Note The values in parentheses are for $f_x = 4.19$ MHz or 6.0 MHz.

Serial interface operation enable/disable specification bit (W)

		Shift register 1	Serial clock counter	IRQCSI flag	SO1, SI1 pin	
★	CSIE1	0	Shift operation disabled	Cleared	Held	Used only for port 8
	1	Shift operation enabled	Count operation	Can be set.	Port 8 is shared with serial function	

Caution Be sure to write 0 in bits 2 to 6 of the serial operation mode register.

(b) Shift register 1 (SIO1)

SIO1 is an 8-bit register which performs parallel-serial conversion and serial transfer (shift) operation in phase with the serial clock.

Serial transfer is started by writing data to SIO1.

In send operation, data written to SIO1 is output on the serial output (SO1). In receive operation, data is read from the serial input (SI1) into SIO1.

Data can be read from or written to SIO1 using an 8-bit manipulation instruction.

When the $\overline{\text{RESET}}$ signal is entered during operation, the value of SIO1 is undefined. When the $\overline{\text{RESET}}$ signal is entered in the standby mode, the value of SIO1 is preserved.

Shift operation is stopped after 8-bit send or receive operation is completed.

The timing for reading SIO1 and start of serial transfer (writing to SIO1) is as follows:

- When the serial interface operation enable/disable bit (CSIE1) is set to 1. However, the case where CSIE1 is set to 1 after data is written to the shift register is excluded.
- When the serial clock is masked after 8-bit serial transfer
- When $\overline{\text{SCK1}}$ is high

(11) Serial interface (channel 1) operation

(a) Operation halt mode

The operation halt mode is used when serial transfer is not performed. This mode reduces power consumption.

Shift register 1 does not perform shift operation in this mode, so the shift register can be used as a normal 8-bit register.

A $\overline{\text{RESET}}$ input sets the operation halt mode.

The P82/SO1 pin and P83/SI1 pin are fixed to function for input ports. The P81/ $\overline{\text{SCK1}}$ pin can be used as an input port pin by setting serial operation mode register 1.

(b) Three-wire serial I/O mode operations

The three-wire serial I/O mode is compatible with other modes used in the 75X series and 78K series. Communication is performed using three lines: Serial clock ($\overline{\text{SCK1}}$), serial output (SO1), and serial input (SI1).

The three-wire serial I/O mode transfers data with eight bits as one block. Data is transferred bit by bit in phase with the serial clock.

Shift register 1 performs shift operation on the falling edge of the serial clock ($\overline{\text{SCK1}}$). Send data is latched on the SO1 latch, and is output on the SO1 pin.

Receive data applied to the SI1 pin is latched in the shift register 1 on the rising edge of $\overline{\text{SCK1}}$.

When eight bits have been transferred, operation of shift register 1 automatically terminates setting the serial transfer end flag (EOT).

Fig. 4-61 Timing of the Three-Wire Serial I/O Mode

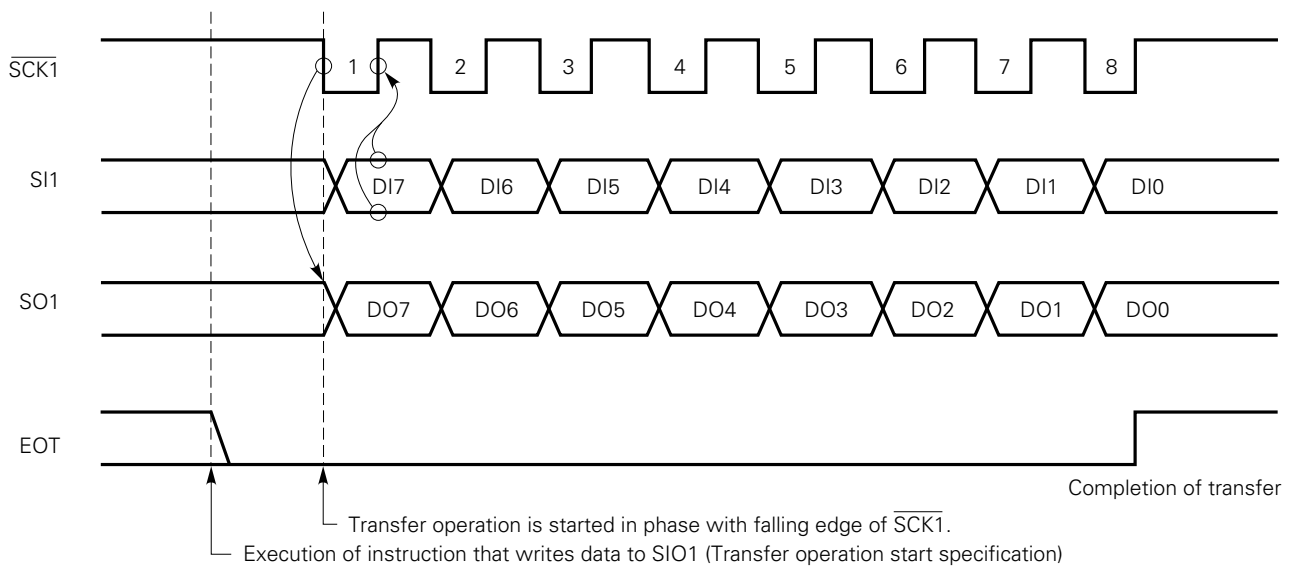

4.10 A/D CONVERTER

The μPD75238 contains an 8-bit analog/digital (A/D) converter that has eight analog input channels (AN0 to AN7).

The A/D converter employs the successive-approximation method.

(1) Configuration of the A/D converter

Fig. 4-62 shows the configuration of the A/D converter.

Fig. 4-62 Block Diagram of the A/D Converter

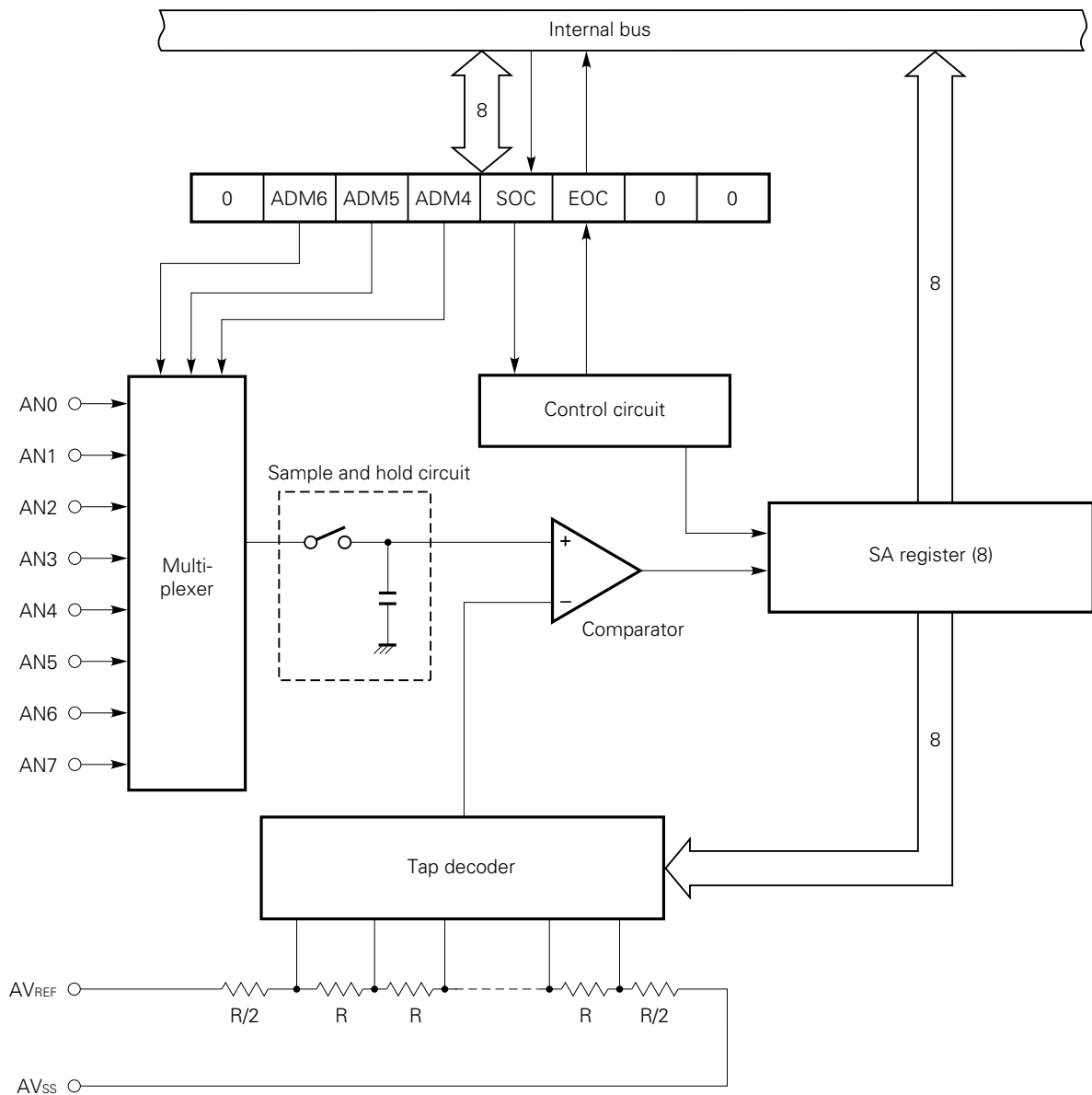

(2) Pins of the A/D converter**(a) AN0 to AN7**

AN0 to AN7 are the input pins for eight analog signal channels. Analog signals subject to A/D conversion are applied to these pins.

The A/D converter contains a sample-and-hold circuit, and analog input voltages are internally maintained during A/D conversion.

(b) AV_{REF}, AV_{SS}

A reference voltage for the A/D converter is applied to these pins.

By using an applied voltage across AV_{REF} and AV_{SS}, signals applied to AN0 to AN7 are converted to digital signals.

AV_{SS} must be always V_{SS}.

★

(c) AV_{DD}

This is the supply voltage pin for the A/D converter. When the A/D converter is not used or is in the standby mode, the potential of the AV_{DD} pin must be equal to that of the V_{DD} pin.

(3) A/D conversion mode register

The A/D conversion mode register (ADM) is an 8-bit register used to select analog input channels, direct the start of conversion, and detect the completion of conversion. (See **Fig. 4-63**.)

ADM is set with an 8-bit manipulation instruction. The conversion completion detection flag (EOC) in bit 2 and the conversion start direction bit (SOC) in bit 3 can be manipulated individually.

A RESET input initializes ADM to 04H. That is, only EOC is set to 1, with all bits cleared to 0.

Fig. 4-63 Format of the A/D Conversion Mode Register

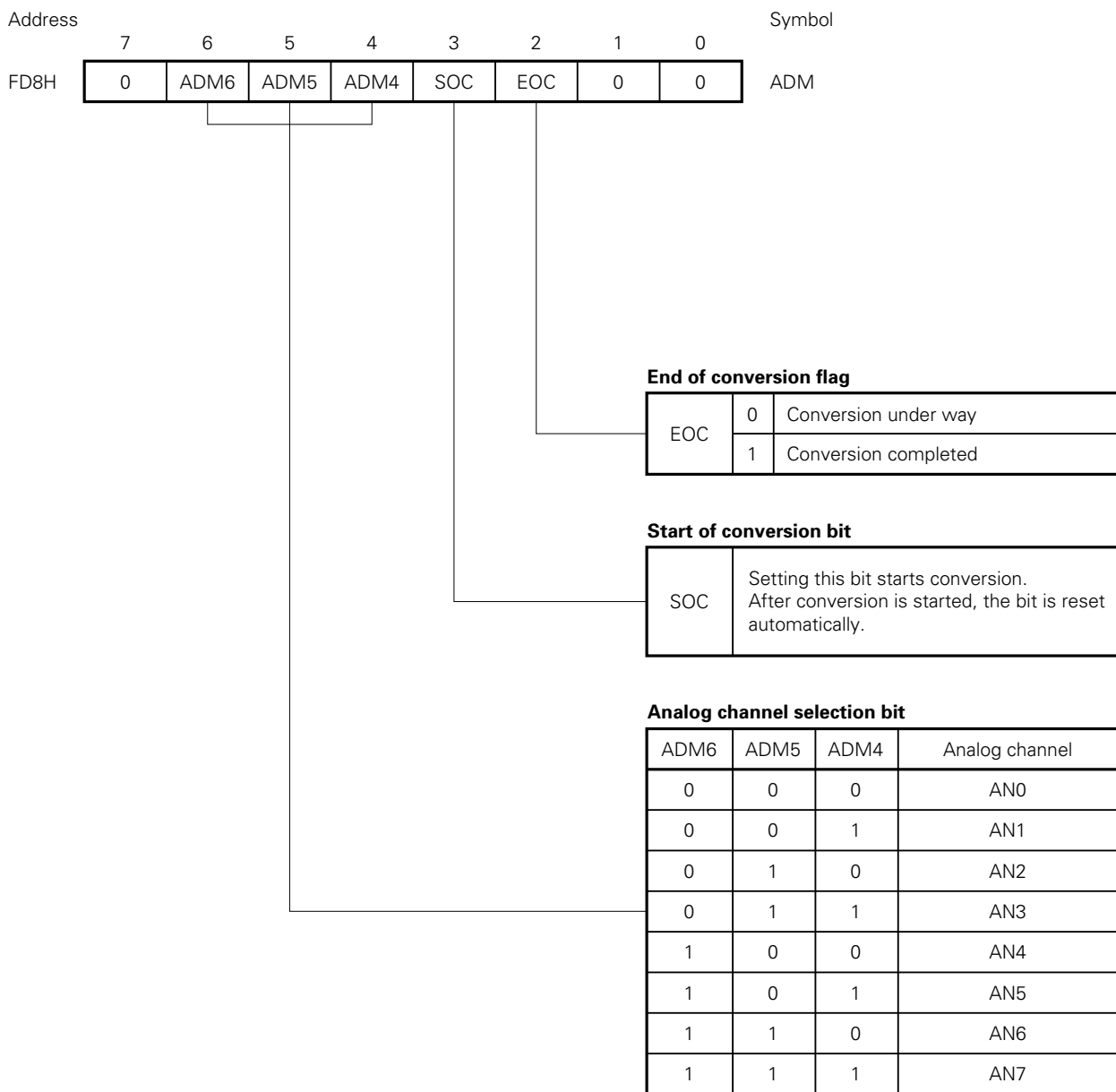

Caution A/D conversion is started a maximum of $2^4/f_x$ seconds ($2.67 \mu s$ at 6.0 MHz)^{Note} after SOC is set. (See (5) in Section 4.10.)

Note $3.81 \mu s$ at 4.19 MHz

(4) SA register (SA)

The SA register (successive approximation register) is an 8-bit register to hold the result of A/D conversion in successive approximation.

SA is read with an 8-bit manipulation instruction. No data can be written to SA by software.

A RESET input sets SA to 7FH.

(5) A/D converter operation

Analog input signals subject to A/D conversion are specified by setting bits 6, 5, and 4 in the A/D conversion mode register (ADM6, ADM5, and ADM4).

A/D conversion is started by setting bit 3 (SOC) of ADM to 1. After that, SOC is automatically cleared to 0. A/D conversion is performed by hardware using the successive-approximation method. The resultant 8-bit data is loaded into the SA register. Upon completion of A/D conversion, bit 2 (EOC) of ADM is set to 1.

Fig. 4-64 shows the timing chart of A/D conversion.

The A/D converter is used as follows:

- ① Select analog input channels (by setting ADM6, ADM5 and ADM4).
- ② Direct the start of A/D conversion (by setting SOC)3
- ③ Wait for the completion of A4D conversion (wait for EOC to be set or wait using a software timer).
- ④ Read the result of A/D conversion (read the SA register).

Cautions 1. ① and ② above can be performed at the same time.

2. There is a delay of up to $2^4/f_x$ seconds ($2.67 \mu s$ at 6.0 MHz)^{Note} from the setting of SOC to the clearing of EOC after A/D conversion is started. EOC must be tested when a time indicated in Table 4-7 has elapsed after the setting of SOC. Table 4-7 also indicates A/D conversion times.

Note $3.81 \mu s$ at 4.19 MHz

Table 4-7 Setting of SCC and PCC

Setting values of SCC, PCC				A/D conversion time	Wait time from SOC setting to EOC test	Wait time from SOC setting to A/D conversion completion
SCC3	SCC0	PCC1	PCC0			
0	0	0	0	$168/f_x$ ($28.0 \mu s$ at 6.0 MHz) ^{Note}	Waiting not required	3 machine cycles
		1	0		2 machine cycles	21 machine cycles
		1	1		4 machine cycles	42 machine cycles
0	1	×	×		Waiting not required	Waiting not required
1	×	×	×	Conversion stopped	—	—

Note $40.1 \mu s$ at 4.19 MHz

Remark ×: Don't care

Fig. 4-64 Timing Chart of A/D Conversion

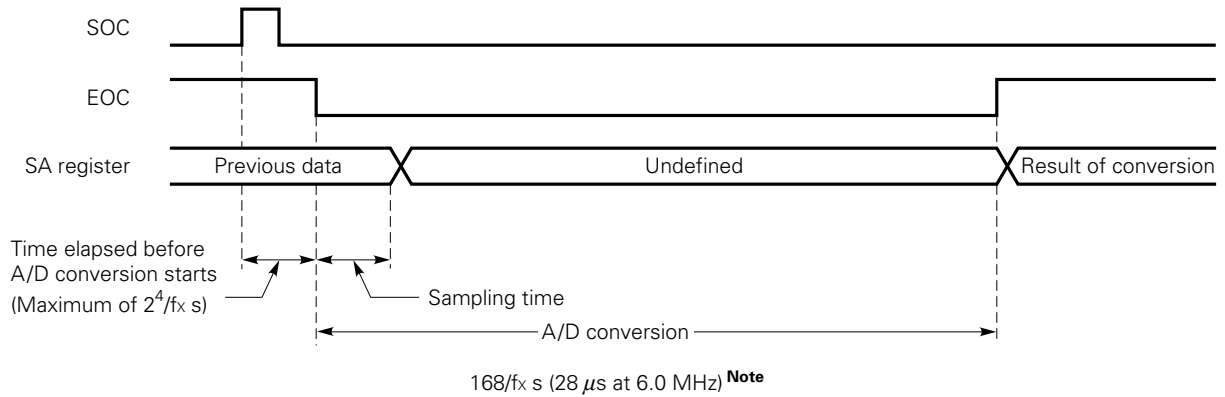

Note 40.1 μs at 4.19 MHz

(6) Notes on the standby mode

The A/D converter operates with the main system clock. So its operation stops in the STOP mode, or when the subsystem clock is used, in the HALT mode. A current flows through the AVREF pin even when the A/D converter is stopped, so that the current must be stopped to reduce overall system power consumption. Since the P21 pin has a higher drive capability than the other ports, it can supply voltage to the AVREF pin directly.

In this case, however, the actual AVREF voltage does not provide precision. This means that the value resulting from conversion does not provide precision and can be used only for relative comparison. In the standby mode, outputting a low on the P21 can reduce power consumption.

In the standby mode, the potential of the AVDD pin must be equal to that of the VDD pin.

Fig. 4-65 Reducing Power Consumption in the Standby Mode

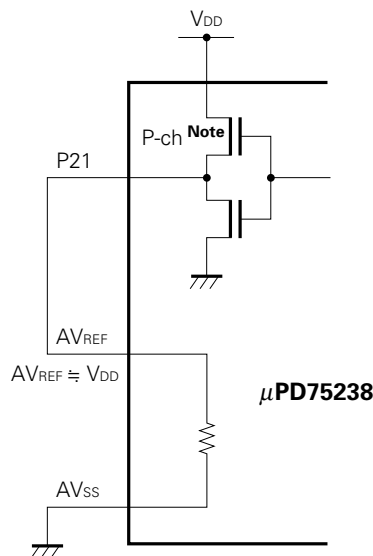

Note The drive capability of P-ch is higher than that of other ports.

(7) Other notes on use

(a) AN0 to AN7 input range

Specified voltages must be applied to AN0 to AN7 inputs. If a voltage higher than V_{DD} or lower than V_{SS} is applied even when the maximum absolute rating is not exceeded, the conversion result for an associated channel becomes unpredictable. In addition, the conversion results for other channels may be affected.

★ (b) Noise protection

To maintain 8-bit resolution, the user should pay attention to noise that may be applied to the AV_{REF} , and AN0 to AN7 pins. Noise adversely affects operation to a greater extent when the analog input source has a higher output impedance. As shown in Fig. 4-66, a capacitor should be externally connected.

Fig. 4-66 Analog Input Pin Connection

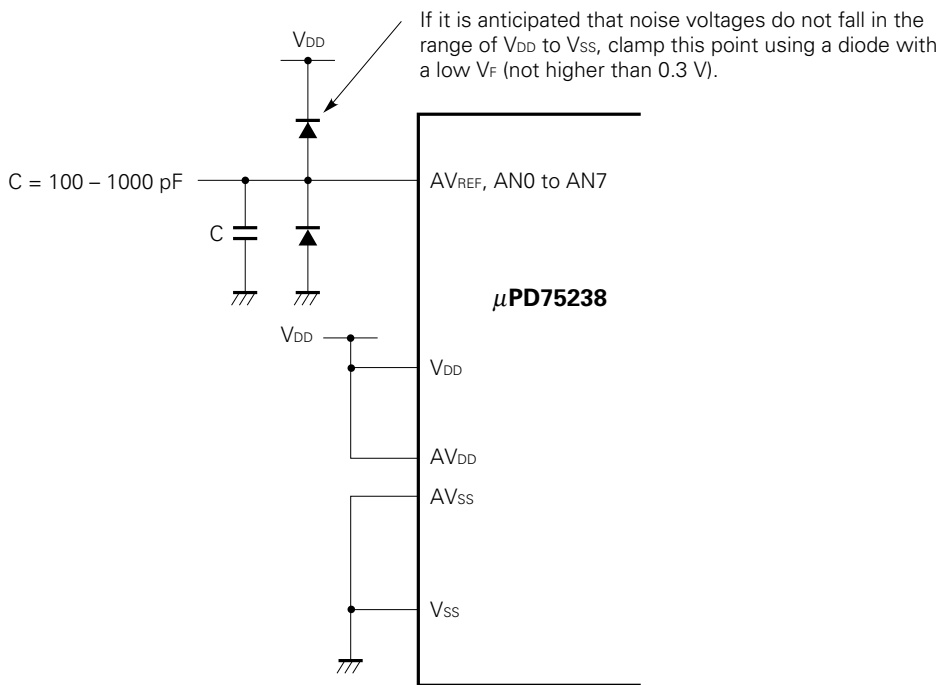

(c) AN4/P90 to AN7/P93 pins

The analog input pins (AN4 to AN7) are also used for an input port (port 9). When any of AN4 to AN7 is selected for A/D conversion, no input instruction must be executed for port 9 during A/D conversion. Otherwise, the accuracy of conversion may deteriorate. If a digital pulse signal is applied to a pin adjacent to a pin being used for A/D conversion, an expected A/D conversion value may not be obtained because of coupling noise. So no digital pulse signal should be applied to the adjacent pin being used for A/D conversion.

★ (d) AV_{DD} pins

When the A/D converter is not used or is in the standby mode, the potential of the AV_{DD} pin must be equal to that of the V_{DD} pin.

4.11 BIT SEQUENTIAL BUFFER: 16 BITS

The bit sequential buffer (BSB0 to BSB3) is special data memory for bit manipulations.

The buffer allows bit manipulations to be performed very easily by sequentially changing address and bit specifications. So the buffer is particularly useful in processing long data bit by bit.

This data memory consists of 16 bits, and allows pmem.@L addressing with a bit manipulation instruction and also allows indirect bit specification using the L register. In this case, only by incrementing or decrementing the L register in a program loop, the bit to be manipulated can be sequentially shifted for continued processing.

Fig. 4-67 Format of the Bit Sequential Buffer

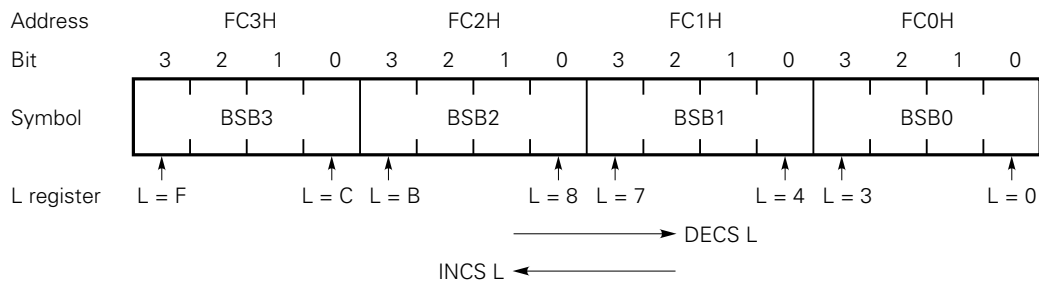

Remark In pmem.@L addressing, bit specification is shifted according to the L register. With pmem.@L addressing, bit sequential buffer can be manipulated at any time regardless of MBE/MBS specification.

Data can also be manipulated using direct addressing. The buffer can be used for applications such as continuous 1-bit data input or output operations by combining direct 1-bit, 4-bit, and 8-bit addressing with pmem.@L addressing. In 8-bit manipulation, the higher eight bits or lower eight bits can be manipulated by specifying BSB0 or BSB2.

4.12 FIP CONTROLLER/DRIVER

(1) Configuration of the FIP controller/driver

The μPD75238 contains a display controller that reads the contents of display data memory by DMA operation and generates digit and segment signals automatically. It also contains a high-voltage output buffer that can directly drive a fluorescent indicator lamp (FIP). Fig. 4-68 shows the configuration of the FIP controller/driver.

Caution The FIP controller/driver can operate only when the high-speed or medium-speed (PCC = 0011B or 0010B) is set for the main system clock (SCC.0 = 0). With the other clocks or in the standby mode, the FIP controller/driver may malfunction. Disable FIP controller operation (DSPM.3 = 0) before entering into the standby mode.

Fig. 4-68 Block Diagram of the FIP Controller/Driver

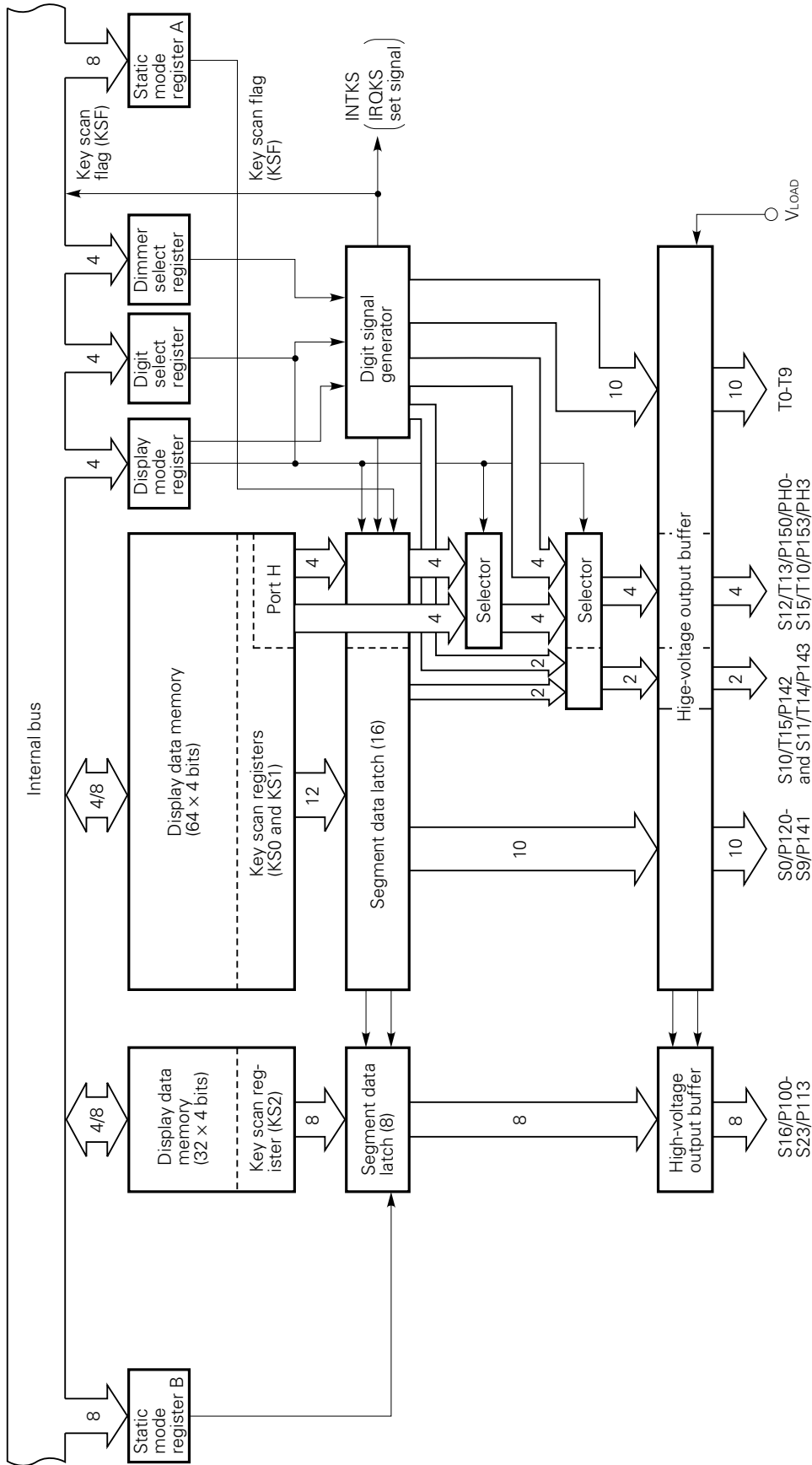

(2) FIP controller/driver functions

The FIP controller/driver contained in the μPD75238 has the following functions:

- (a) The FIP controller/driver automatically reads display data and generates a segment signal (DMA operation) and a digit signal.
- (b) An FIP having 9 to 24 segments and 9 to 16 digits can be controlled with the display mode register (DSPM), digit select register (DIGS), static mode register A (STATA), and static mode register B (STATB). (Up to 34 display outputs are allowed.)
- (c) Any outputs not used for dynamic display can be used as static outputs or output ports.
- (d) The dimmer function provides eight levels of intensity.
- (e) Hardware that makes key scan application possible
 - An interrupt (IRQKS) is caused for key scanning (detection of key scan timing).
 - Key scan data can be output on a segment output with key scan buffers (KS0, KS1, and KS2).
- (f) A high-voltage output pin (40 V) is provided which can directly drive the FIP.
 - Segment output pins (S0 to S9, S16 to S23): $V_{OD} = 40\text{ V}$, $I_{OD} = 3\text{ mA}$
 - Digit output pins (T0 to T15): $V_{OD} = 40\text{ V}$, $I_{OD} = 15\text{ mA}$
- (g) Mask options for display output pins
 - A pull-down resistor to V_{LOAD} can be incorporated bit by bit for T0 to T9 and S0 to S15.
 - A pull-down resistor to V_{LOAD} or V_{SS} can be incorporated bit by bit for S16 to S23. V_{LOAD} or V_{SS} must be selected in 8-bit units.

(3) Difference of the display output function between the μPD75238, μPD75216A, and μPD75217

Table 4-8 shows the difference of the display output function between the μPD75238, μPD75216A, and μPD75217.

Table 4-8 Difference of the Display Output Function between the μPD75238, μPD75216A, and μPD75217

	μPD75238	μPD75216A, μPD75217
High-voltage output display	FIP output total : 34 Segment output : 9 - 24 Digit output : 9 - 16	FIP output total : 26 Segment output : 9 - 16 Digit output : 9 - 16
Display data area	1A0H-1FFH	1C0H-1FFH
Output dual-function pin	S0-S23 (Port 10-port 15)	S12-S15 (Port H)
Key scan register	KS0-KS2	KS0, KS1

Fig. 4-69 FIP Controller Operation Timing

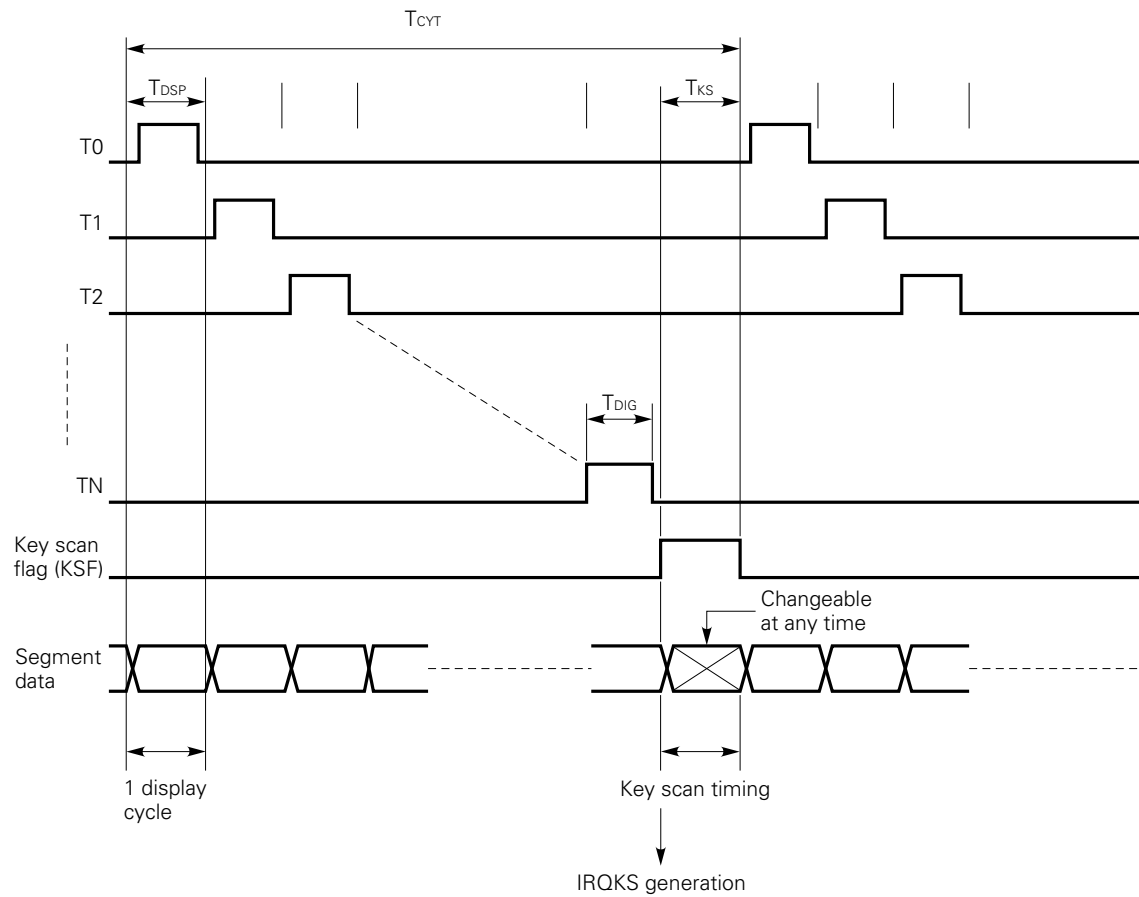

N : Value set in the digit select register

T_{DSP}: One display cycle (1024/fx: 171 μs at 6.0 MHz^{Note 1} or 2048/fx: 341 μs at 6.0 MHz^{Note 2})

T_{CYT}: Display cycle ($T_{CYT} = T_{DSP} \times (N + 2)$)

T_{DIG}: Digit signal pulse width, which can be selected from eight levels with the dimmer select register

Notes 1. 244 μs at 4.19 MHz

2. 489 μs at 4.19 MHz

(4) Display mode register (DSPM)

The display mode register (DSPM) is a 4-bit register for enable/disable setting for the display operation and for specifying the number of display segments. Fig. 4-70 shows the format of the register.

The display mode register is set with a 4-bit memory manipulation instruction.

Before a standby mode (STOP mode or HALT mode) can be set or the subsystem clock (f_{XT}) can be used for operation, display must be disabled by setting DSPM.3 to 0.

A $\overline{\text{RESET}}$ input clears all bits to 0.

Fig. 4-70 Display Mode Register Format

Address	3	2	1	0	Symbol
F88H	DSPM3	DSPM2	DSPM1	DSPM0	DSPM

Bit for specifying the number of display segments

DSPM2	DSPM1	DSPM0	Number of display segments
0	0	0	9 segments (+ 8 segments)
0	0	1	10 segments (+ 8 segments)
0	1	0	11 segments (+ 8 segments)
0	1	1	12 segments (+ 8 segments)
1	0	0	13 segments (+ 8 segments)
1	0	1	14 segments (+ 8 segments)
1	1	0	15 segments (+ 8 segments)
1	1	1	16 segments (+ 8 segments)

Remark Segments in parentheses are added when pins S16 to S23 are specified as dynamic mode in STATB.

Display operation enable/disable bit

DSPM3	0	Display disabled
	1	Display enabled

(5) Digit select register (DIGS)

The digit select register (DIGS) is a 4-bit register that specifies the number of display digits. Fig. 4-71 shows the format of the register.

DIGS is set with a 4-bit memory manipulation instruction. This register enables the number of display digits to be selected from 9 to 16 digits. No other values can be selected.

A $\overline{\text{RESET}}$ input initializes the register to 1000B so that 9-digit display is selected.

Fig. 4-71 Digit Select Register Format

Address	3	2	1	0	Symbol
F8AH	DIGS3	DIGS2	DIGS1	DIGS0	DIGS

Caution Do not set a value from 0 to 7 for N.

DIGS0-3 set value	Number of display digits
N (= 8 to 15)	N + 1

(6) Dimmer select register (DIMS)

The dimmer select register (DIMS) is a 4-bit register for specifying a digit signal cut width to prevent display light leakage and to use the dimmer function (for intensity control). In addition, the register is used to select a display cycle (T_{DSP}).

Fig. 4-72 shows the format of DIMS.

DIMS is set with a 4-bit memory manipulation instruction.

A display cycle of 341 μs at 6.0 MHz^{Note 1} is usually selected by setting 1 in DIMS.0 for reduced light leakage. However, as the number of display digits increases, the display cycle becomes closer to the frequency of commercial power, causing the display to fricker. In this case, a display cycle of 171 μs at 6.0 MHz^{Note 2} should be selected. If light leakage occurs in this case, adjust cutting width of the digit single by setting DIMS.1, DIMS.2, and DIMS.3.

A RESET input clears all bits to 0.

- Notes**
1. 489 μs at 4.19 MHz
 2. 244 μs at 4.19 MHz

Fig. 4-72 Dimmer Select Register Format

Address		Symbol				
F89H	<table border="1" style="display: inline-table; border-collapse: collapse;"> <tr> <td style="padding: 2px;">DIMS3</td> <td style="padding: 2px;">DIMS2</td> <td style="padding: 2px;">DIMS1</td> <td style="padding: 2px;">DIMS0</td> </tr> </table>	DIMS3	DIMS2	DIMS1	DIMS0	DIMS
DIMS3	DIMS2	DIMS1	DIMS0			

Display cycle specification bit

DIMS0	0	A display cycle is $\frac{1024}{f_x}$. (One cycle = 171μs/6.0 MHz) Note 1
	1	A display cycle is $\frac{2048}{f_x}$. (One cycle = 341μs/6.0 MHz) Note 2

Digit signal cut width specification bit

DIMS3	DIMS2	DIMS1	Digit signal cut width
0	0	0	1/16
0	0	1	2/16
0	1	0	4/16
0	1	1	6/16
1	0	0	8/16
1	0	1	10/16
1	1	0	12/16
1	1	1	14/16

- Notes**
1. 244 μs at 4.19 MHz
 2. 489 μs at 4.19 MHz

(7) Static mode registers

A static mode registers are registers used to specify static output/dynamic output of the segment output pins.

There are two static mode registers: static mode register A and static mode register B. Fig. 4-73 and Fig. 4-74 show their formats.

These registers are set with an 8-bit manipulation instruction. A $\overline{\text{RESET}}$ input clears all bits to 0.

(a) Static mode register A (STATA)

Static mode register A (STATA) is a register to specify static output/dynamic output of the S0/P120 to S15/P153/T10/PH3 pins.

Fig. 4-73 Static Mode Register A (STATA)

Address	7	6	5	4	3	2	1	0	Symbol
FD6H	0	0	0	0	STATA3	STATA2	STATA1	STATA0	STATA

S0 to S15 pins Static output/dynamic output selection bit

STATA3	STATA2	STATA1	STATA0	Output status of S0 to S15 pins
0	0	0	0	S0 to S15 become dynamic outputs. The number of segments and the number of digits are set by DSPM and DIGS.
1	1	1	1	S0 to S15 become static outputs. Static data is output by issuing an output instruction for ports 12 to 15. The outputs are independent of the value of DSPM.3.

Caution Part of the S0 to S15 pins cannot be set as dynamic outputs while the other pins are set as static outputs.

(b) Static mode register B (STATB)

Static mode register B (STATB) is a register to specify static output/dynamic output of the S16/P100 to S23/P113 pins.

Fig. 4-74 Static Mode Register B (STATB)

Address	7	6	5	4	3	2	1	0	Symbol
FD4H	0	0	STATB5	STATB4	0	0	0	0	STATB

S16 to S23 pins Static output/dynamic output selection bit

STATB5	STATB4	Output status of S16 to S23 pins
0	0	S16 to S23 become dynamic outputs. Output depends on the contents of 1A0H to 1BDH.
1	1	S16 to S23 become static outputs. Static data is output by issuing an output instruction for ports 10 and 11. The outputs are independent of the value of DSPM.3.

Caution Part of the S16 to S23 pins cannot be set as dynamic outputs while the other pins are set as static outputs.

(8) Selection of display mode

The number of segments and number of digits which can be displayed by the internal FIP controller/driver are determined by display modes.

Fig. 4-75 shows the selection of display mode.

Fig. 4-75 Selection of Display Mode

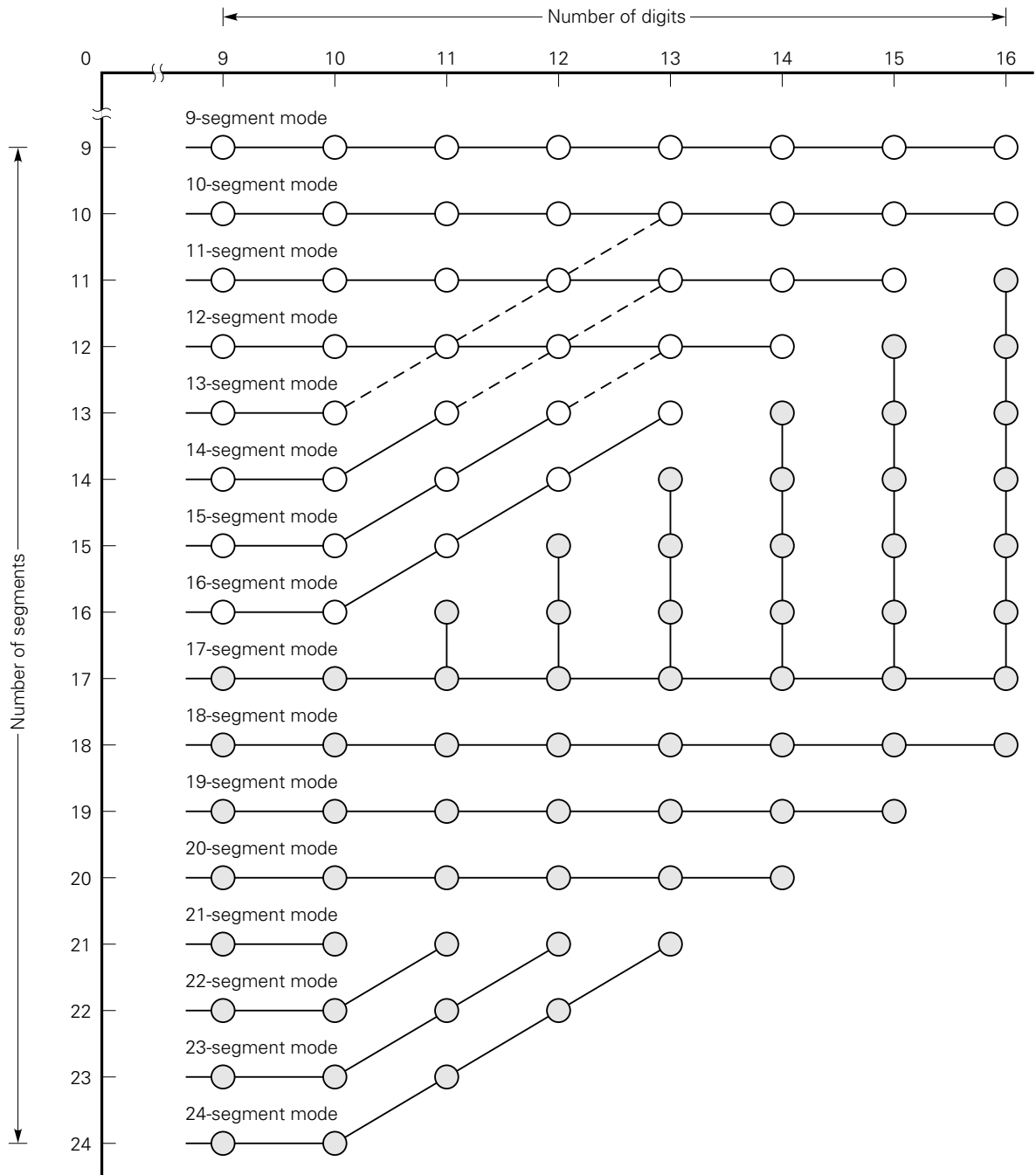

Remark The shaded circles indicate extended modes derived from the μPD75216A and μPD75217.

(9) Display data memory

Display data memory stores segment data for display. It is mapped to addresses 1A0H to 1FFH in data memory. The display controller automatically reads display data (DMA operation). Area not used for display can be used as normal data memory.

Display data is manipulated with data memory manipulation instructions in 1-, 4-, and 8-bit units. With 8-bit manipulation instructions, only even-numbered addresses can be specified.

Display data memory locations at 1FCH to 1FFH, 1BEH, and 1BFH are also used as key scan registers KS0, KS1, and KS2.

Table 4-9 Data Memory Locations Also Used as Key Scan Registers

Key scan register	Data memory locations
KS0	1FCH, 1FDH
KS1	1FEH, 1FFH
KS2	1BEH, 1BFH

Caution Special care must be paid when a program developed for the μPD75238 is transported to the μPD75216A or the μPD75217. This is because the μPD75216A and the μPD75217 allow up to 16 display segments, and do not contain data memory at the addresses (1A0H + 4n, 1A1H + 4n).

Fig. 4-76 Correspondence between Display Data Memory and Segment Output

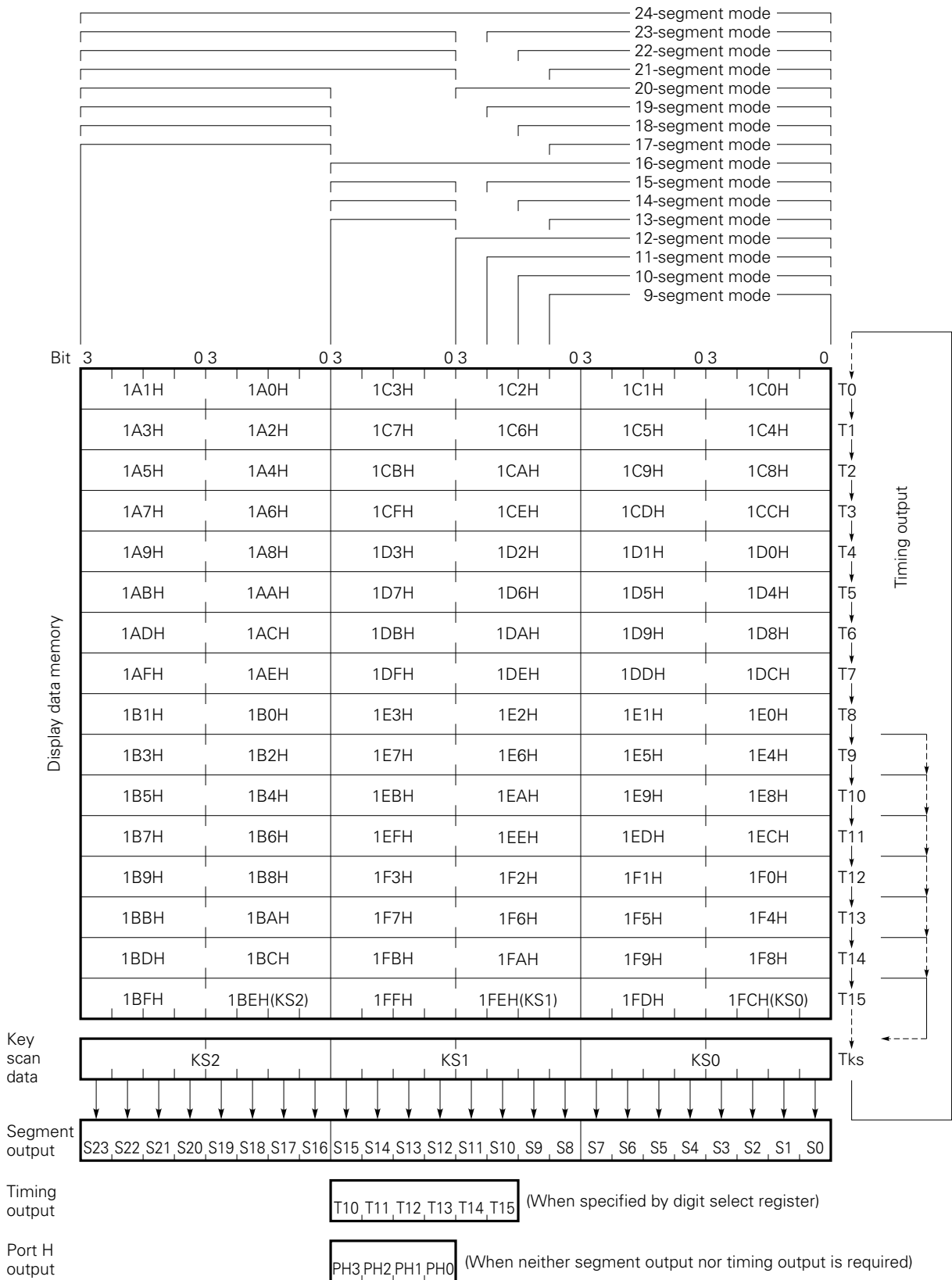

(10) Key scan registers (KS0, KS1, and KS2)

The key scan registers (KS0, KS1, and KS2) set segment output data on the key scan timing that is mapped to display data memory locations (1FCH, 1FDH, 1FEH, 1FFH, 1BEH, and 1BFH).

KS0, KS1, and KS2 are 8-bit registers, which are usually manipulated with an 8-bit manipulation instruction. (One-bit or 4-bit manipulation is also possible for the lower 4 bits.)

The data set in KS0, KS1, and KS2 is output on the segment output pins on the key scan timing. During the key scan timing, the rewriting of KS0, KS1, and KS2 is immediately reflected in segment output data, which can be used for key scanning.

(11) Key scan flag (KSF)

The key scan flag (KSF) is set to 1 on the key scan timing, and is automatically reset to 0 on any other timing. KSF is mapped to bit 3 at address F8AH, and can be tested on a single-bit basis. KSF cannot be written to. Testing this flag can determine whether the key scan timing is present, so that the validity of key input data can be determined.

5. INTERRUPT FUNCTION

The μPD75238 has eight interrupt sources and can handle multiple interrupts with a priority.

The μPD75238 is also provided with two test sources. One test source, INT2, is set by edge detection testable input.

Table 5-1 Interrupt Sources

Interrupt source		In/out	Priority ^{Note 1}	Vector interrupt request signal (vector table address)
INTBT	(Reference time interval signal from basic interval timer)	In	1	VRQ1 (0002H)
INT4	(Detection of rising or falling edge)	Out		
INT0	(Rising/falling edge detection specification)	Out	2	VRQ2 (0004H)
INT1		Out	3	VRQ3 (0006H)
INTCSIO	(Serial data transfer completion signal)	In	4	VRQ4 (0008H)
INTT0	(Match signal from timer enter/counter 0)	In	5	VRQ5 (000AH)
INTTPG	(Match signal from timer/pulse generator)	In	6	VRQ6 (000CH)
INTKS	(Key scan timing signal from display controller)	In	7	VRQ7 (000EH)
INT2 ^{Note 2}	(Detection of rising edge)	Out	Testable input signal (Sets IRQ2 and IRQW.)	
INTW ^{Note 2}	(Signal from clock timer)	In		

- Notes**
1. The priority is used when two or more interrupt requests are issued at a time.
 2. INT2 and INTW are test sources. Like interrupt sources, these test sources are controlled by an interrupt enable flag. But, they do not cause vector interrupts.

The following functions are provided for the interrupt control circuit of the μPD75238.

- (a) Vector interrupt function under hardware control which can determine whether to accept an interrupt by an interrupt enable flag (IE_{xxx}) and the interrupt master enable flag (IME)
- (b) Any interrupt start address can be set.
- (c) Multiple interrupt function which can specify the priority by the interrupt priority specification register (IPS)
- (d) Test function of an interrupt request flag (IRO_{xxx})
(The software can confirm that an interrupt occurred.)
- (e) Release of the standby mode (Interrupts released by an interrupt enable flag can be selected.)

5.1 CONFIGURATION OF THE INTERRUPT CONTROL CIRCUIT

The interrupt control circuit of the μPD75238 is configured as shown in Fig. 5-1. Each hardware item is mapped in the data memory space.

Fig. 5-1 Block Diagram of Interrupt Control Circuit

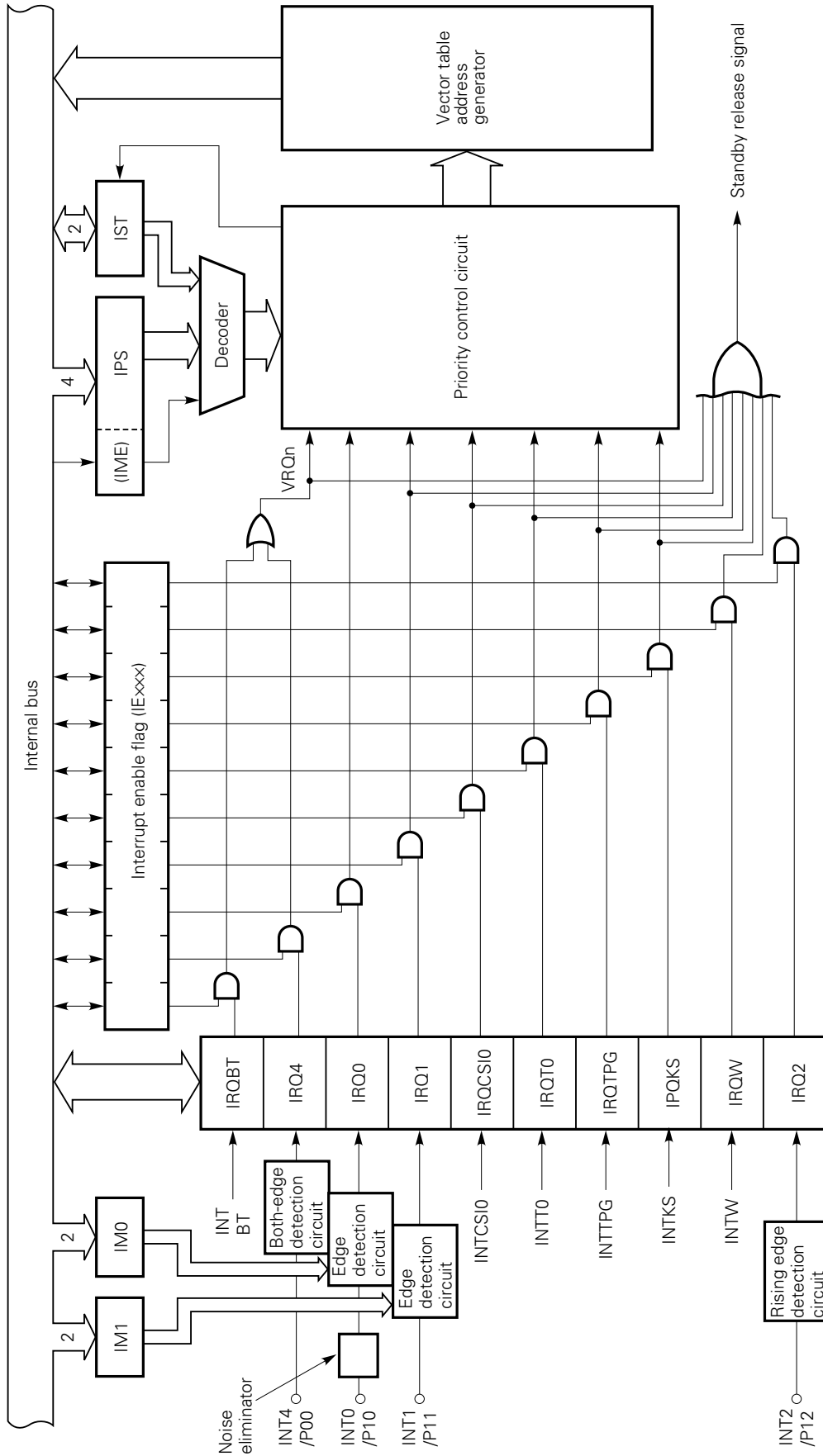

5.2 HARDWARE OF THE INTERRUPT CONTROL CIRCUIT

(1) Interrupt request flag and interrupt enable flag

There are ten interrupt request flags (IRQ_{xxx}), listed below, each corresponding to a particular interrupt or test source; there are 8 interrupt and 2 test sources. ★

INT0 interrupt request flag (IRQ0)	Serial interface interrupt request flag (IRQCSI0)
INT1 interrupt request flag (IRQ1)	Timer/event counter interrupt request flag (IRQT0)
INT2 interrupt request flag (IRQ2)	Timer/pulse generator interrupt request flag (IRQTPG)
INT4 interrupt request flag (IRQ4)	Key scan interrupt request flag (IRQKS)
BT interrupt request flag (IRQBT)	Clock timer interrupt request flag (IRQW)

The interrupt request flag is set to 1 when an interrupt request is issued, and is automatically cleared to 0 when the CPU is interrupted. Since the IRQBT and IRQ4 share the vector address, the clear operation varies. (See **Section 5.5**.)

There are ten interrupt enable flags (IE_{xxx}), listed below, each corresponding to a particular interrupt request flag. ★

INT0 interrupt enable flag (IE0)	Serial interface interrupt enable flag (IECSI0)
INT1 interrupt enable flag (IE1)	Timer/event counter interrupt enable flag (IET0)
INT2 interrupt enable flag (IE2)	Timer/pulse generator interrupt enable flag (IETPG)
INT4 interrupt enable flag (IE4)	Key scan interrupt enable flag (IEKS)
BT interrupt enable flag (IEBT)	Clock timer interrupt enable flag (IEW)

When an interrupt request flag is set, the interrupt enable flag corresponding to that interrupt request flag enables the request interrupt. When an interrupt request flag is cleared, the interrupt enable flag corresponding to that interrupt request flag disables the interrupt.

When an interrupt request flag is set and its corresponding interrupt enable flag enables the requested interrupt, a vector interrupt request (VRQ_n) is issued. This signal is also used for releasing the standby mode.

The interrupt request flags and interrupt enable flags are manipulated with bit manipulating instructions and 4-bit memory manipulation instructions. When a bit manipulation instruction is used, the flags can always be manipulated directly irrespective of the MBE setting. The interrupt enable flags are manipulated with EI IE_{xxx} and DI IE_{xxx} instructions. An SKTCLR instruction is normally used to test an interrupt request flag.

When an interrupt request flag is set with an instruction, a vector interrupt is executed irrespective of whether an interrupt occurs.

A RESET input clears an interrupt request flag and its corresponding interrupt enable flag to 0 and all interrupts are disabled.

Table 5-2 Set Signals of Interrupt Request Flags

Interrupt request flag	Set signal of interrupt request flag	Interrupt enable flag
IRQBT	Set by a reference time interval signal from the basic interval timer.	IEBT
IRQ4	Set by a detected rising or falling edge of an INT4/P00 pin input signal.	IE4
IRQ0	Set by a detected edge of an INT0/P10 pin input signal. The detection edge is specified by the INT0 mode register (IM0).	IE0
IRQ1	Set by a detected edge of an INT1/P11 pin input signal. The detection edge is specified by the INT1 mode register (IM1).	IE1
IRQCSI0	Set by a serial data transfer completion signal for the serial interface.	IECSI0
IRQT0	Set by a match signal from timer/event counter 0.	IET0
IRQTPG	Set by a match signal from the timer/pulse generator.	IETPG
IRQKS	Set by a key scan timing signal from the display controller.	IEKS
IRQW	Set by a signal from the clock timer.	IEW
IRQ2	Set by a detected rising edge of an INT2/P12 pin input signal.	IE2

★ (2) **Noise eliminator and edge detection mode register**

As shown in Fig. 5-2 and Fig. 5-3, the INT0, INT1, and INT2 pins are configured as external interrupt input pins that enable detection edge selection.

In addition, INT0 is provided with a noise elimination function based on a sampling clock. Basically, the noise eliminator eliminates pulses narrower than two sampling clock cycles^{Note} as noise. However, it may accept pulses wider than one sampling clock cycle as interrupt signals depending on the sampling timing. It surely accepts pulses wider than two sampling clock cycles as interrupt signals.

INT0 has two sampling clocks Φ and $f_x/64$, either of which can be selected according to bit 3 (IM03) of the edge detection mode register (see Fig. 5-4).

The IRQ2 is set by detecting a rising edge of the INT2 pin input.

The edge detection mode registers (IM0 and IM1) used to select a detection edge have the format shown in Fig. 5-4. A 4-bit memory manipulation instruction is used to set IM0 or IM1. A RESET input clears all bits to 0, and a rising edge is selected for INT0, INT1, and INT2.

Note When a sampling clock is Φ , two sampling clock cycles are $2tcy$.
When a sampling clock is $f_x/64$, two sampling clock cycles are $128/f_x$.

Cautions 1. Since the INT0 pin input is sampled with a clock, INT0 does not operate in a standby mode.
2. When INT0/P10 is used as a port, pulses input from INT0/P10 go through the noise eliminator. So the input pulses must be wider than two sampling clock cycles.

Fig. 5-2 Configuration of INT0 and INT1

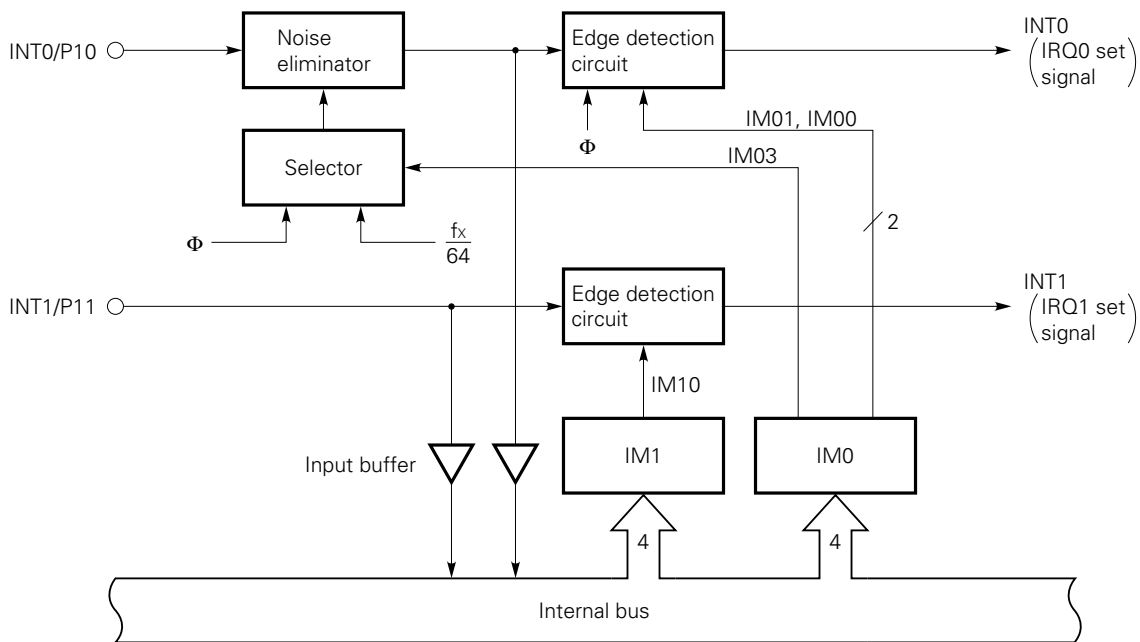

Fig. 5-3 Configuration of INT2

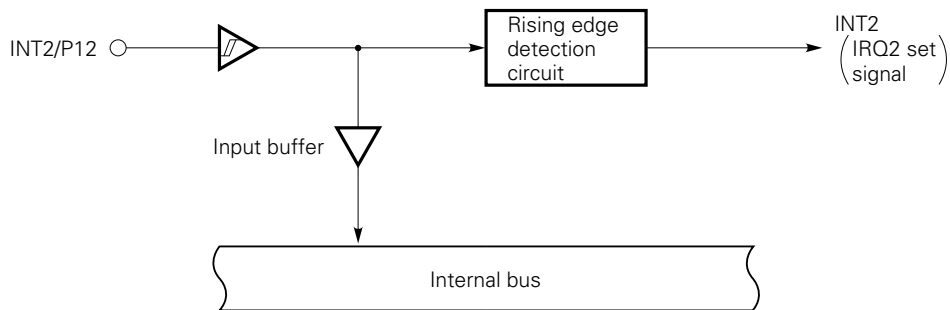
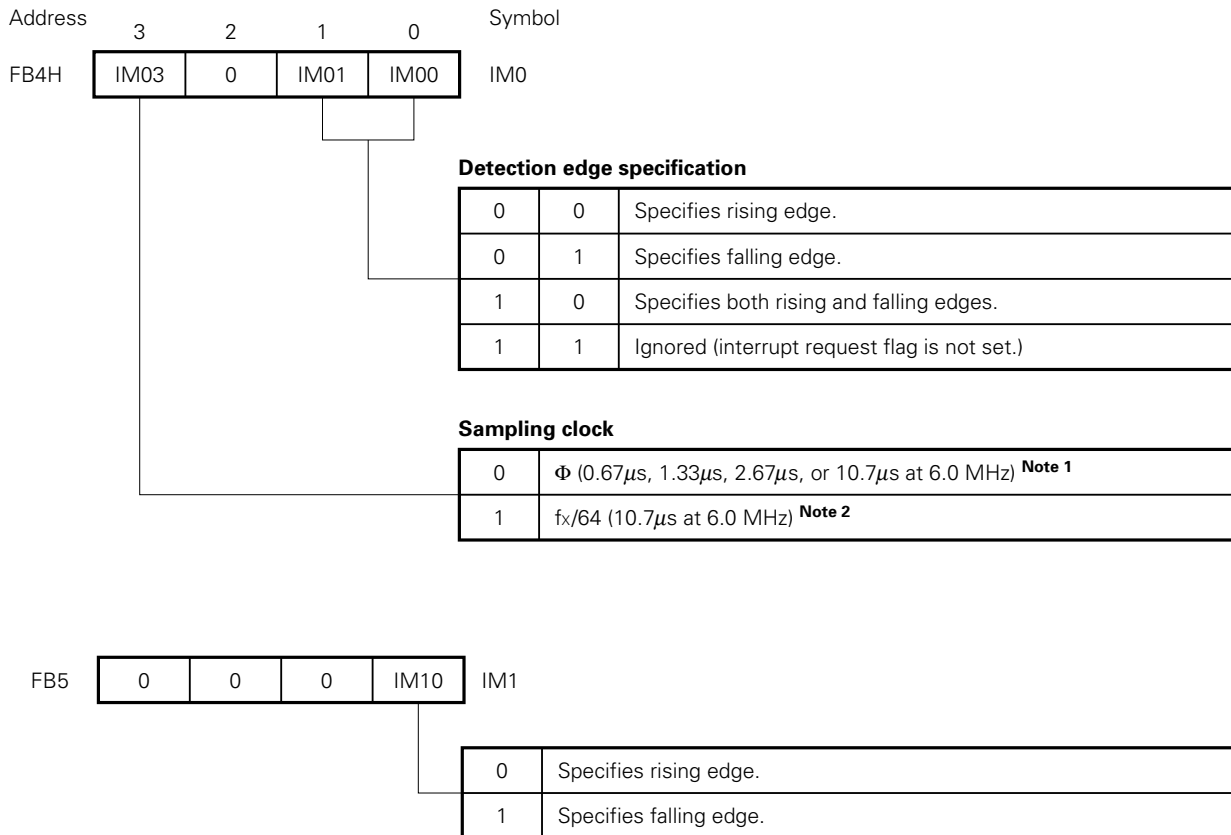

Fig. 5-4 Format of Edge Detection Mode Registers



Notes 1. 0.95 μs, 1.91 μs, 3.82 μs, or 15.3 μs at 4.19 MHz

2. 15.3 μs at 4.19 MHz

Caution Since changing the edge detection mode register may set an interrupt request flag, disable the interrupts before changing the edge detection mode register. Then clear the interrupt request flag with a CLR1 instruction and enable the interrupts. When f_x/64 is selected as a sampling clock pulse in changing IM0, wait for 16 machine cycles after changing the mode register and clear the interrupt request flag.

(3) Interrupt priority specification register (IPS)

The interrupt priority specification register specifies an interrupt with a higher priority from multiple interrupts using the low-order three bits.

Bit 3, interrupt master enable flag (IME), specifies whether to disable all interrupts.

The IPS is set with a 4-bit memory manipulation instruction. Bit 3 is set with an EI instruction and reset with a DI instruction.

When changing the low-order three bits of the IPS, interrupts must be disabled (IME = 0) beforehand. A $\overline{\text{RESET}}$ input clears all bits to 0.

Fig. 5-5 Interrupt Priority Specification Register

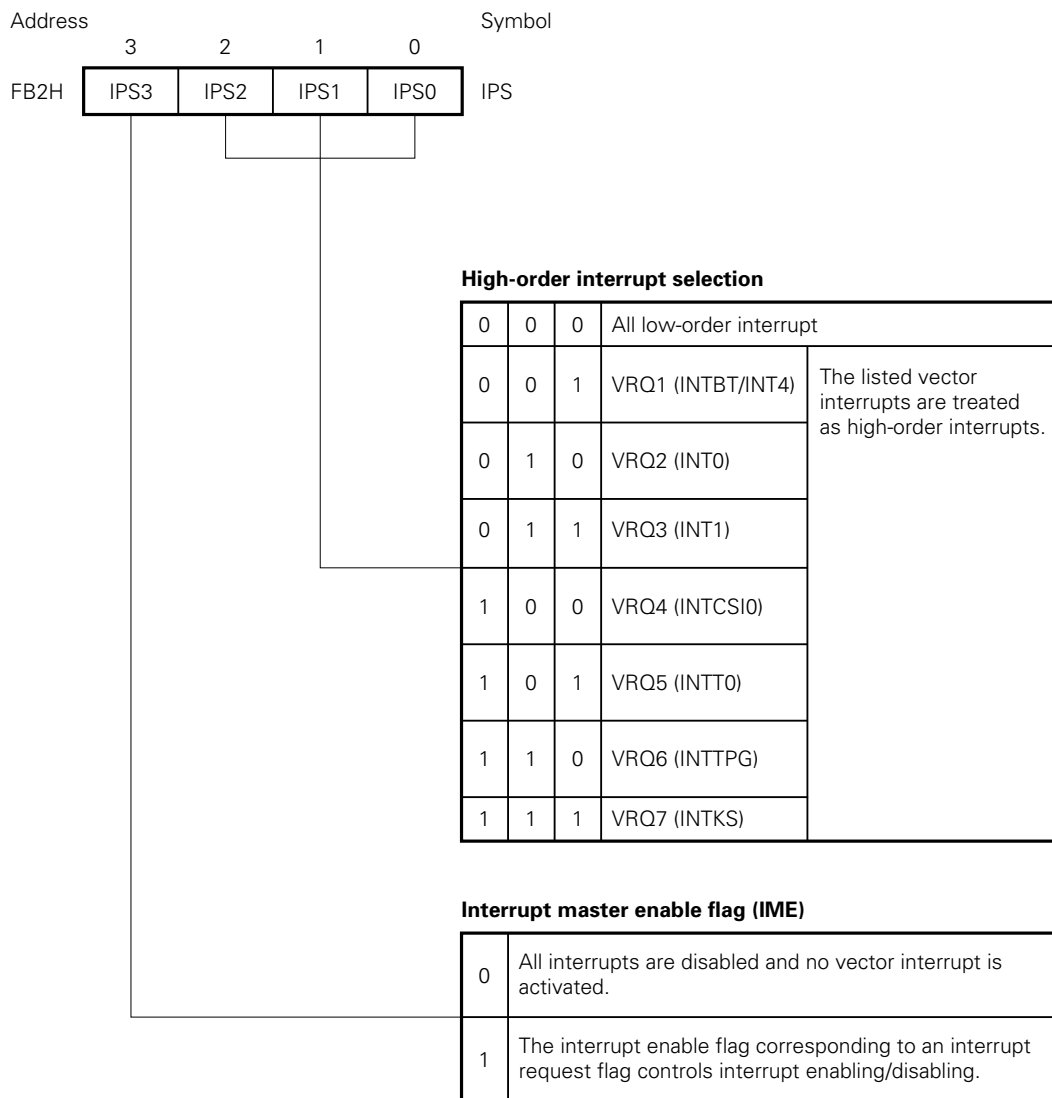

5.3 INTERRUPT SEQUENCE

The following flowchart shows the sequence of an interrupt.

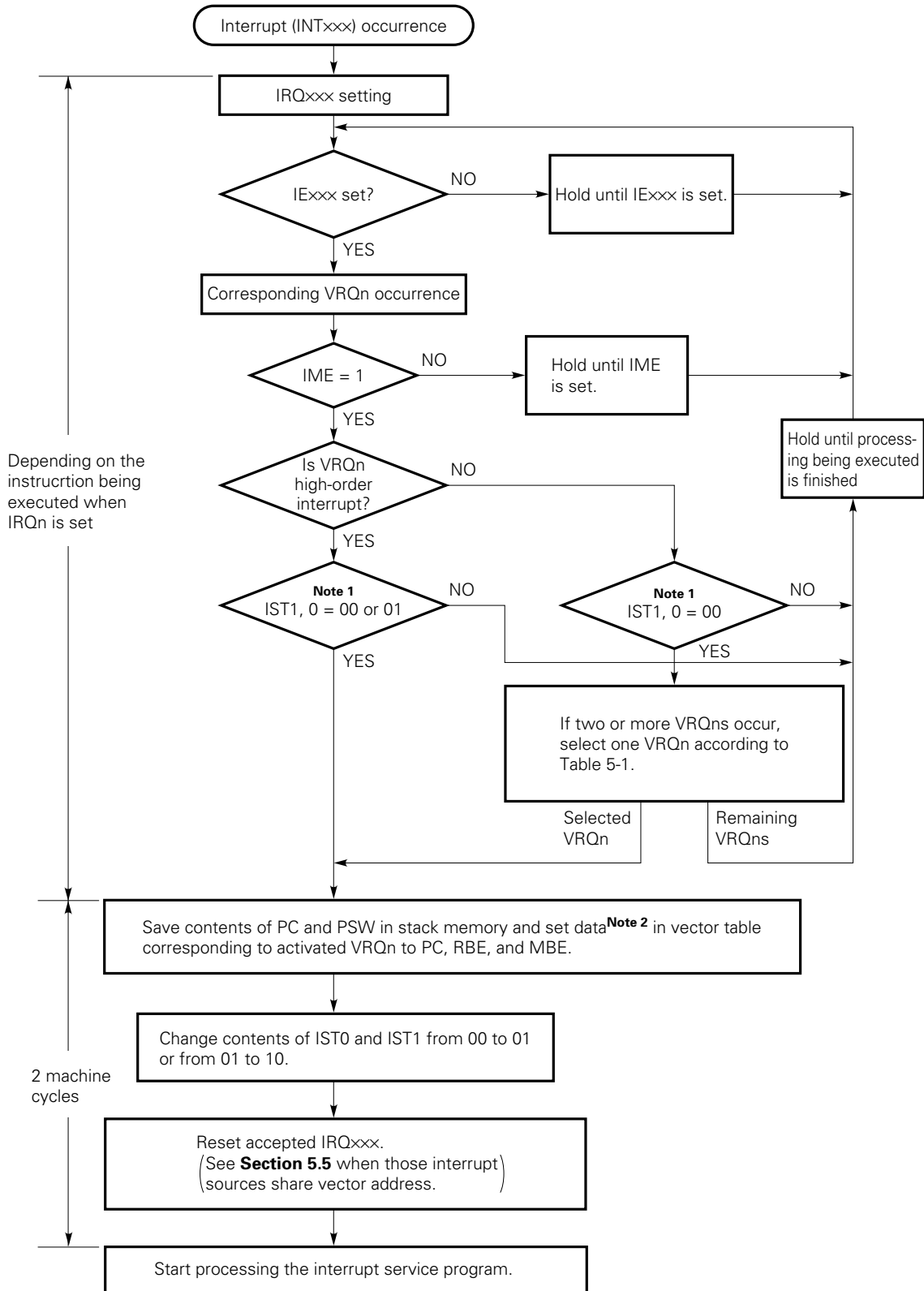

Notes 1. IST1 and IST0: Interrupt status flags (Bits 3 and 2 of PSW. See Table 5-3.)

2. Each vector table must store the start address of the interrupt service program and the set values of the MBE and RBE at the start of an interrupt.

5.4 MULTIPLE INTERRUPT PROCESSING CONTROL

The μPD75238 can handle multiple interrupts by either of the following methods.

(1) Multiple interrupt processing by a high-order interrupt

In this method, the μPD75238 selects an interrupt source among multiple interrupt sources, enabling double interrupt processing.

That is, the high-order interrupt specified by the interrupt priority specification register (IPS) is enabled when the processing status is 0 or 1. Other interrupts (interrupts lower than the specified high-order interrupt) are enabled only when the status is 0. (See Fig. 5-6 and Table 5-3.)

Fig. 5-6 Multiple Interrupt Processing by a High-Order Interrupt

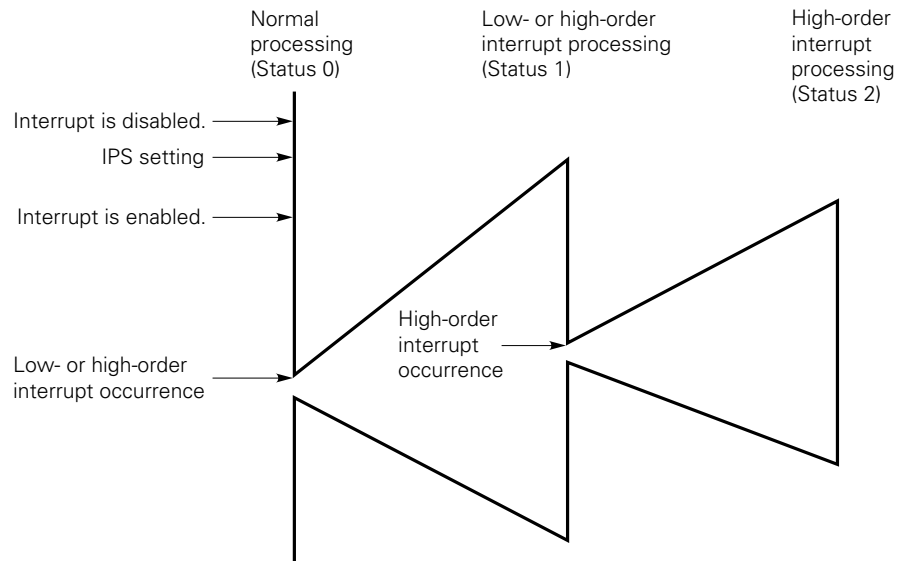

Table 5-3 Interrupt Processing Statuses of IST1 and IST0

IST1	IST0	Processing status	CPU operation	Interrupts that can be accepted	After acceptance		
					IST1	IST0	
0	0	Status 0	Is processing the normal program.	All	0	1	
0	1	Status 1	Is processing a low- or high-order interrupt.	Only high-order interrupts	1	0	
1	0	Status 2	Is processing a high-order interrupt.	None	-	-	
1	1	This status is disabled.					

IST1 and IST0 are saved with the remaining PSW in the stack memory when an interrupt is accepted and the status of IST0 and IST1 changes to a status one level higher. When an RETI instruction is executed, the former values of IST0 and IST1 are returned.

(2) Multiple interrupt processing by changing the interrupt status flags

As shown in Table 5-3, changing the interrupt status flags with the program causes multiple interrupts to be enabled. That is, when the interrupt processing program changes both IST1 and IST0 to 0 (status 0), multiple interrupt processing is enabled.

This method is used when two or more interrupts are to be enabled at a time or when the processing of three or more interrupts is to be performed.

When changing IST1 and IST0, interrupts must be disabled beforehand with a DI instruction.

Fig. 5-7 Multiple Interrupt Processing by Changing the Interrupt Status Flags

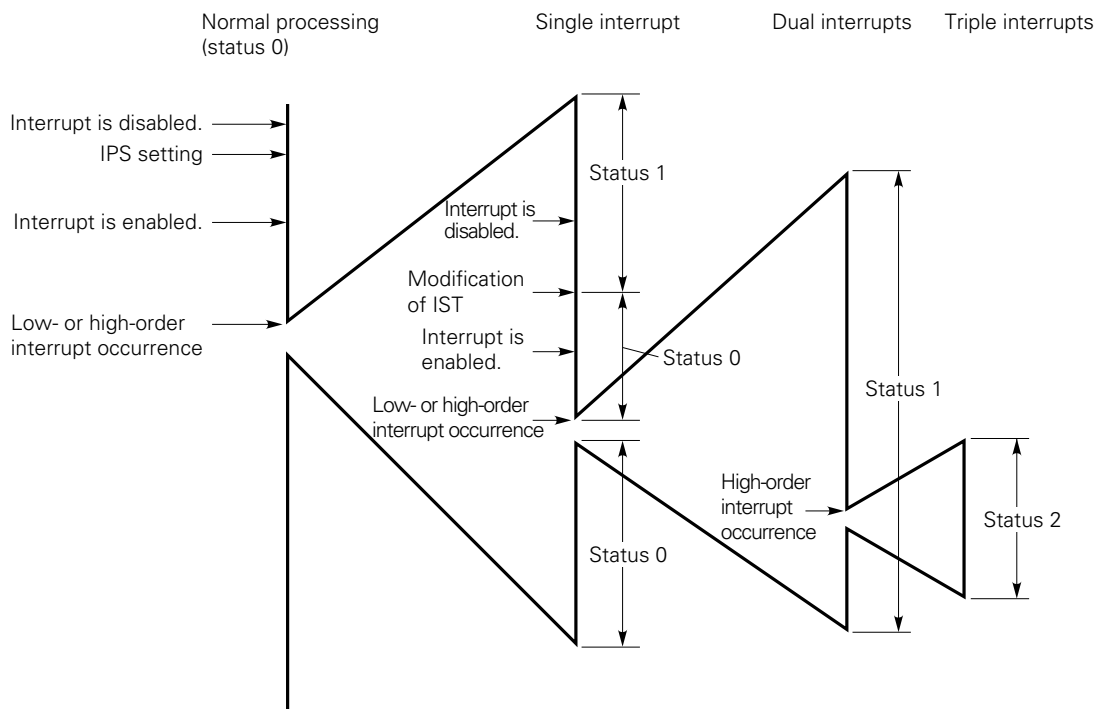

5.5 VECTOR ADDRESS SHARE INTERRUPT PROCESSING

Since interrupt sources INTBT and INT4 share the vector table, the following two cases must be considered.

(1) When using only one interrupt source

The interrupt enable flag corresponding to the required interrupt source of the two interrupt sources sharing the vector table is set and the other interrupt enable flag is cleared. In this case, the enabled interrupt source ($IE_{xxx} = 1$) issues an interrupt request. If this request is accepted, the corresponding interrupt request flag is reset. (The same operation as that of interrupts not sharing a vector address)

(2) When using both interrupt sources

The interrupt enable flags corresponding to the two interrupt sources are set. In this case, the logical and of the interrupt request flags corresponding to the two interrupt sources is an interrupt request.

Even if one or both of the interrupt request flags are set and an interrupt request is accepted, neither of the interrupt request flags is reset.

The interrupt service routine must therefore judge which interrupt source caused an interrupt. This is done by executing a DI instruction at the beginning of the interrupt service routine and checking the interrupt request flags with an SKTCLR instruction.

6. STANDBY FUNCTION

To reduce the power consumption when the program is in the wait state, the μPD75238 has two standby modes, STOP and HALT.

6.1 SETTING OF STANDBY MODES AND OPERATION STATUSES

Table 6-1 Operation Statuses in the Standby Mode

		STOP mode	HALT mode
Instruction for setting		STOP instruction	HALT instruction
System clock at setting		This mode can be set only when the main system clock is used.	This mode can be set when either the main system clock or the subsystem clock is used.
Operation status	Clock generator	Only the main system clock is stopped.	Only CPU clock (Φ) is stopped (with oscillation continued).
	Serial interface (Channel 0)	Operation is possible only when external $\overline{\text{SCK0}}$ input is selected for the serial clock.	Operation is possible only when the main system clock operates or external $\overline{\text{SCK0}}$ is used.
	Serial interface (Channel 1)	Operation is possible only when external $\overline{\text{SCK1}}$ input is selected for the serial clock.	Operation is possible only when the main system clock operates.
	Basic interval timer	Operation is stopped.	Operation is continued (to set IRQBT at reference time intervals).
	Timer/event counter	Operation is possible only when T10 pin input is selected for the count clock.	Operation is possible.
	Watch timer	Operation is possible only when f_{XT} is selected for the count clock.	Operation is possible.
	Timer/pulse generator	Operation is stopped.	Operation is possible only when the main system clock operates.
	Event counter	Operation is stopped.	Operation is possible only when the main system clock operates.
	A/D converter	Operation is stopped.	Operation is possible only when the main system clock operates.
	FIP controller/driver	Operation is disabled. (The display off mode is selected before setting.)	
	External interrupt	INT0 is disabled. INT1, INT2, and INT4 are enabled.	
	CPU	Operation is stopped.	
Release signal		Interrupt request signals sent out from hardware, which are enabled by interrupt enable flags, or RESET input.	

A STOP instruction is used to set the STOP mode, and a HALT instruction is used to set the HALT mode. (A STOP instruction sets bit 3 of PCC, and a HALT instruction sets bit 2 of PCC.)

When changing a CPU operation clock pulse with the low-order two bits of PCC, a time lag may occur from the time when PCC is rewritten to the time when the CPU clock signal is changed as indicated in Table 4-1. When changing an operation clock pulse before the standby mode or a CPU clock signal after the standby mode is released, it is necessary to rewrite PCC and set the standby mode after the number of machine cycles required to change the CPU clock pulse elapses.

In a standby mode, the contents of all registers and data memory that are stopped during the standby mode, including general registers, flags, mode registers, and output latches, are retained.

- Cautions 1. When the STOP mode is set, the X1 input is internally connected to V_{ss} (GND potential) to suppress leakage at the crystal oscillator circuitry. This means that the STOP mode cannot be used with a system that uses an external clock.**
- 2. An interrupt request signal is used to release a standby mode. This means that if an interrupt source whose interrupt request flag and interrupt enable flag are both set exists, the initiated standby mode is released immediately after it is set. When the STOP mode is set, therefore, the μ PD75238 enters the HALT mode immediately after the STOP instruction is executed, then returns to the operation mode after the wait time specified by the BTM register has elapsed.**

6.2 RELEASE OF THE STANDBY MODES

The STOP mode and HALT mode are released by a $\overline{\text{RESET}}$ input or the generation of an interrupt request signal^{Note} that is enabled with the interrupt enable flag. Fig. 6-1 shows how the STOP and HALT modes are released.

Note INT0 to INT2 are excluded.

Fig. 6-1 Standby Mode Release Operation

(a) Release of the STOP mode by $\overline{\text{RESET}}$ input

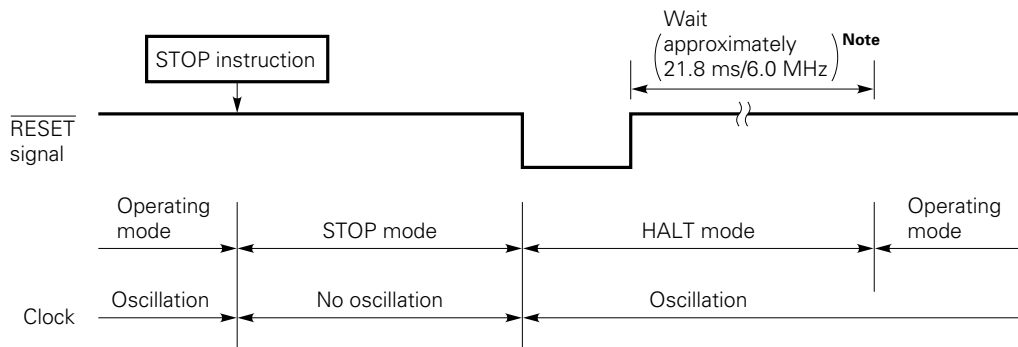

(b) Release of the STOP mode by the occurrence of an interrupt

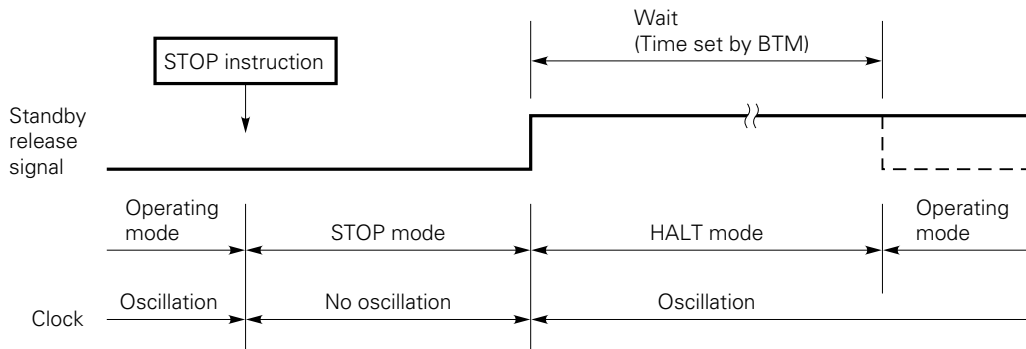

Remark The dashed line indicates the case where the interrupt request that releases the standby mode is accepted (IME = 1).

(c) Release of the HALT mode by $\overline{\text{RESET}}$ input

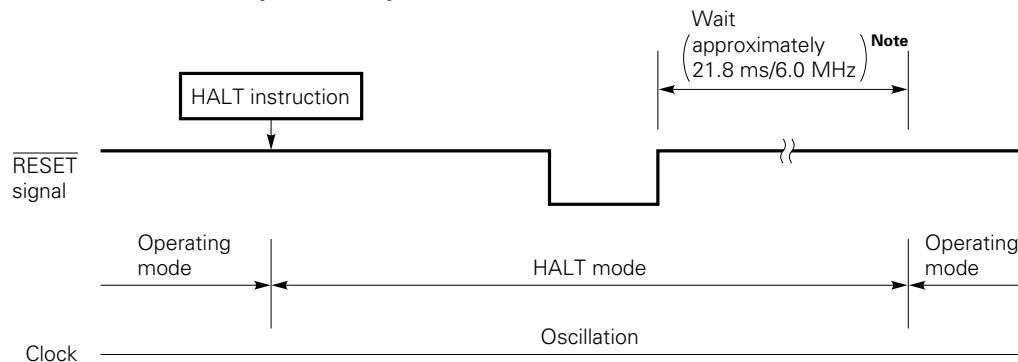

Note 31.3 ms at 4.19 MHz.

(d) Release of the HALT mode by the occurrence of an interrupt

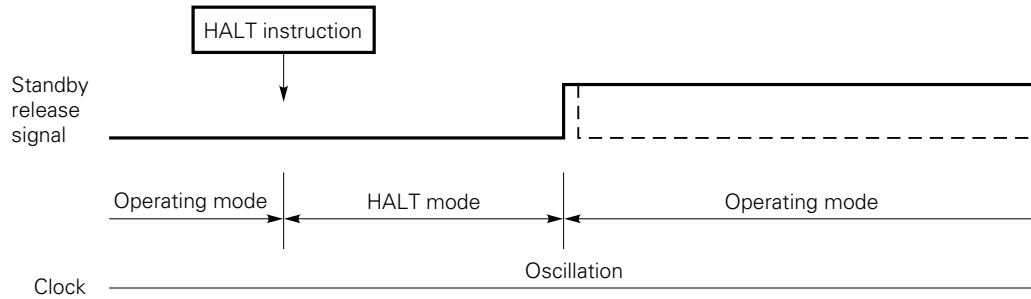

Remark The dashed line indicates the case where the interrupt request that releases the standby mode is accepted (IME = 1).

The wait times used when the STOP mode is released do not include a time (a in the figure below) required before clock generation is started following the release of the STOP mode, regardless of whether the STOP mode is released by RESET signal input or the generation of an interrupt.

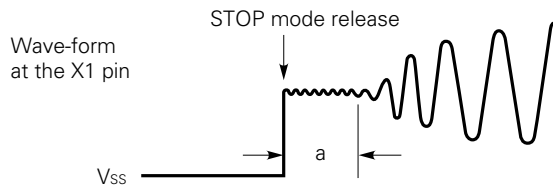

When the STOP mode is released by the occurrence of an interrupt, a wait time is determined by BTM. (See Table 6-2.)

Table 6-2 Selection of a Wait Time with BTM

(When $f_x = 6.0$ MHz)

BTM3	BTM2	BTM1	BTM0	Wait time ^{Note} . () indicates the value for $f_x = 6.0$ MHz
-	0	0	0	Approx. $2^{20}/f_x$ (Approx. 175 ms)
-	0	1	1	Approx. $2^{17}/f_x$ (Approx. 21.8 ms)
-	1	0	1	Approx. $2^{15}/f_x$ (Approx. 5.46 ms)
-	1	1	1	Approx. $2^{13}/f_x$ (Approx. 1.37 ms)
Other than above				Use prohibited

(When $f_x = 4.19$ MHz)

BTM3	BTM2	BTM1	BTM0	Wait time ^{Note} . () indicates the value for $f_x = 4.19$ MHz
-	0	0	0	Approx. $2^{20}/f_x$ (Approx. 250 ms)
-	0	1	1	Approx. $2^{17}/f_x$ (Approx. 31.3 ms)
-	1	0	1	Approx. $2^{15}/f_x$ (Approx. 7.82 ms)
-	1	1	1	Approx. $2^{13}/f_x$ (Approx. 1.95 ms)
Other than above				Use prohibited

Note This time does not include the time from the release of the STOP mode to the start of oscillation.

6.3 OPERATION AFTER A STANDBY MODE IS RELEASED

- (1) If a standby mode is released by a $\overline{\text{RESET}}$ input, normal reset operation is performed.
- (2) If a standby mode is released by the occurrence of an interrupt request, bit 3 of the IPS (IME) determines whether to perform a vectored interrupt when the CPU resumes instruction execution.

(a) When IME = 0

After the standby mode is released, execution of an instruction (NOP instruction) is restarted immediately after the instruction which set the standby mode.

The interrupt request flag is held.

(b) When IME = 1

After the standby mode is released, two instructions are executed, then a vector interrupt is caused. However, when the standby mode is released by INTW or INT2 (input of a testable signal), no vector interrupt is caused and the same processing as (a) above is performed.

7. RESET FUNCTION

Fig. 7-1 shows the configuration of the reset ($\overline{\text{RES}}$) signal generator.

Fig. 7-1 Reset Signal Generator

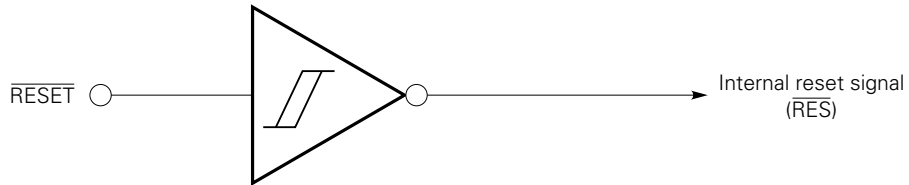
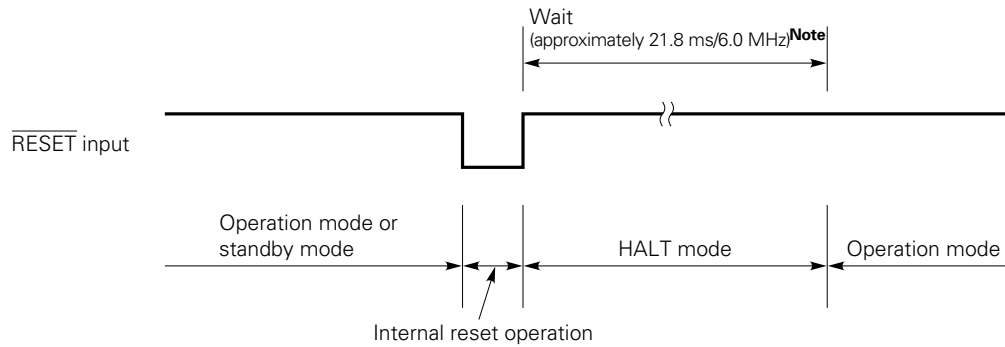

Fig. 7-2 shows reset operation.

The output buffer is set to off at the time of a $\overline{\text{RESET}}$ input.

After a reset, the hardware is initialized as indicated in Table 7-1.

Fig. 7-2 Reset Operation by $\overline{\text{RESET}}$ Input



Note 31.3 ms at 4.19 MHz.

After a reset, the hardware is initialized as indicated in Table 7-1.

Table 7-1 Statuses of the Hardware after a Reset (1/2)

Hardware		RESET input in a standby mode	RESET input during operation
Program counter (PC)		Low-order 6 bits at address 0000H in program memory are set in PC bits 13 to 8, and the data at address 0001H are set in PC bits 7 to 0.	Low-order 6 bits at address 0000H in program memory are set in PC bits 13 to 8, and the data at address 0001H are set in PC bits 7 to 0.
PSW	Carry flag (CY)	Held	Undefined
	Skip flags (SK0 to SK2)	0	0
	Interrupt status flags (IST1, IST2)	0	0
	Bank enable flags (MBE, RBE)	Bit 6 at address 0000H in program memory is set in RBE, and bit 7 is set in MBE.	Bit 6 at address 0000H in program memory is set in RBE, and bit 7 is set in MBE.
Data memory (RAM)		Held	Undefined
General registers (X, A, H, L, D, E, B, C)		Held	Undefined
Bank select register (MBS, RBS)		0, 0	0, 0
Stack pointer (SP)		Undefined	Undefined
Stack bank select register (SBS)		Undefined	Undefined
Basic interval timer	Counter (BT)	Undefined	Undefined
	Mode register (BTM)	0	0
Timer/event counter	Counter (T0)	0	0
	Modulo register (TMOD0)	FFH	FFH
	Mode register (TM0)	0	0
	TOE0, TOUT F/F	0, 0	0, 0
Watch timer	Mode register (WM)	0	0
Timer/pulse generator	Modulo registers (MODH, MODL)	Held	Held
	Mode register (TPGM)	0	0
Event counter	Counter (T1)	0	0
	Mode register (TM1)	0	0
	Gate control register (GATEC)	0	0
Serial interface (Channel 0)	Shift register (SIO0)	Held	Undefined
	Operation mode register (CSIM0)	0	0
	SBI control register (SBIC)	0	0
	Slave address register (SVA)	Held	Undefined
	P01/SCK0 output latch	1	1
Serial interface (Channel 1)	Shift register (SIO1)	Held	Undefined
	Operation mode register (CSIM1)	0	0
	Serial transfer end flag (EOT)	0	0

Table 7-1 Statuses of the Hardware after a Reset (2/2)

Hardware		$\overline{\text{RESET}}$ input in a standby mode	$\overline{\text{RESET}}$ input during operation
A/D converter	Mode register (ADM), EOC	04H (EOC = 1)	04H (EOC = 1)
	SA register	Undefined	Undefined
Bit sequential buffers (BSB0 to BSB3)		Held	Undefined
FIP controller/ driver	Mode register (DSPM)	0	0
	Dimmer select register (DIMS)	0	0
	Digit select register (DIGS)	8H	8H
	Display data memory	Held	Held
	Output buffer	Off	Off
	Static mode registers (STATA, STATB)	0, 0	0, 0
Clock generator, clock output circuit	Processor clock control register (PCC)	0	0
	System clock control register (SCC)	0	0
	Clock output mode register (CLOM)	0	0
Interrupt	Interrupt request flag (IRQ _{xxx})	Reset	Reset
	Interrupt enable flag (IE _{xxx})	0	0
	Interrupt master enable flag (IME)	0	0
	INT0 and INT1 mode registers (IM0, IM1)	0, 0	0, 0
Digital ports	Output buffer (Ports 2 to 7)	Off	Off
	Output latch (Ports 2 to 7)	Clear	Clear
	I/O mode registers (PMGA, PMGB)	0	0
	Pull-up resistor specification register (POGA)	0	0
Ports 10 to 15	Output buffer	Off	Off
	Output latch	0	0
Port H	Output latch	Held	Undefined

8. INSTRUCTION SET

8.1 μPD75238 INSTRUCTIONS

(1) GETI instruction

The GETI instruction references a two-byte table in the program memory and performs the following three types of operations. This single-byte instruction is very useful in reducing the number of program steps.

- (a) A subroutine call is made to a 16-KB space (0000H to 3FFFH), regarding data in a table as the call address of a call instruction.
- (b) A branch is made to a 16-KB space (0000H to 3FFFH), regarding data in a table as the branch address of a branch instruction.
- (c) Data in a table is executed as a double-byte instruction excluding BRCB and the CALLF instructions.
- (d) Data in a table is executed as the instruction code of two single-byte instructions.

As shown in Fig. 3-2, the tables to be referenced by a GETI instruction are located at addresses 0020H to 007FH in the program memory. That is, data can be set in up to 48 tables.

When describing a table address as an operand, describe an even address.

Cautions 1. A two-byte instruction which can be referenced by a GETI instruction must be a two-machine-cycle instruction.

2. When referencing two single-byte instructions with a GETI instruction, only the combinations listed in the table below are valid.

Instruction of first byte	Instruction of second byte
MOV A,@HL MOV @HL,A XCH A,@HL	<ul style="list-style-type: none"> (INCS L DECS L (INCS H DECS H INCS HL
MOV A,@DE XCH A,@DE	<ul style="list-style-type: none"> (INCS E DECS E (INCS D DECS D INCS DE
MOV A,@DL XCH A,@DL	<ul style="list-style-type: none"> (INCS L DECS L (INCS D DECS D

3. Branch and subroutine instructions can be referenced by the GETI instruction only when the addresses of the destination and subroutine call are in the 16K-byte space (0000H to 3FFFH). A branch or subroutine instruction to an address from 4000H to 7F7FH cannot be referenced by the GETI instruction.

Since PC does not increment the counter during execution of a GETI instruction, control returns to the address next to the GETI instruction after the execution of the GETI instruction.

When the instruction before a GETI instruction has the skip function, the GETI instruction is skipped in the same way as for other single-byte instructions. When the instruction referenced by a GETI instruction has the skip function, the instructions after the GETI instruction are skipped.

When a string effect instruction is referenced by a GETI instruction, the following results are obtained.

- When the group of the string effect instruction before the GETI instruction is the same as that of the instruction referenced by the GETI instruction, the effect of the string effect instruction is canceled and the referenced instruction is not skipped.
- When the group of the instruction after the GETI instruction is the same as that of the instruction referenced by the GETI instruction, the effect of the string effect instruction caused by the referenced instruction is valid and the instructions after the referenced instruction are skipped.

(2) Bit manipulation instructions

The μPD75238 is provided with bit test instructions, bit transfer instructions, and bit Boolean instructions (AND, OR, and XOR) in addition to normal bit manipulation instructions (set instruction and clear instruction). Manipulation bits are specified by bit manipulation addressing.

There are three types of bit manipulation addressing. The table below lists the bits manipulated by each addressing.

Addressing	Specifiable peripheral hardware	Specifiable bit address range
fmem.bit	RBE/MBE/IST1, IST0/IE _{xxx} /IRQ _{xxx}	FB0H to FBFH
	Port 0 to port 6	FF0H to FFFH
pmem.@L	Port 0 and port 4	FC0H to FFFH
@H+mem.bit	All the peripheral hardware (bit-manipulatable)	All the bits of the memory bank specified by MB (bit-manipulatable)

(xxx: 0, 1, 2, 4, BT, T0, TPG, CSI0, KS, W
 MB = MBE• MBS

(3) String effect instructions

When two or more instructions in the same group (group A or B) are placed at two or more string effect addresses, the instruction placed at the start point of the string effect instructions is executed. After that, each string effect instruction is executed as an NOP instruction.

Group A: MOV A, #n4, MOV XA, #n8

Group B: MOV HL, #n8

(4) Base conversion instruction

The μ PD75238 is provided with base conversion instructions to convert the results of addition and subtraction of 4-bit data to a base-n number.

When a base-m number is to be obtained, the following combinations of instructions are used for adjustment.

- For addition ADDS A, #16-m
 ADDC A, @HL
 ADDS A, #m
- For subtraction SUBC A, @HL
 ADDS A, #m

The result of adding or subtracting the contents of the accumulator and the memory addressed by the HL register pair is converted to a base-m number. However, for subtraction, the complement of the obtained result (base-m number) is set in the accumulator. An overflow or underflow is reflected in the carry flag. (In the above combinations, the skip function of the ADDS A, #m instruction is prohibited.)

8.2 INSTRUCTION SET AND ITS OPERATION

(1) Representation format and description method of operands

An operand is described in the operand field of each instruction according to the description method corresponding to the operand representation format of the instruction. Refer to the assembler specifications for details. When two or more elements are described in the description method field, select one of them. Uppercase letters, a plus sign (+), and a minus sign (-) are keywords, so they can be used without alteration.

Specify an appropriate numeric value or label for immediate data.

The symbols shown in format diagrams in Chapters 3 to 5 can be used as a label instead of mem, fmem, pmem, and bit. However, there are some restrictions on usable labels for fmem and pmem. (See (2) in Section 8.1.)

Representa- tion format	Description method
reg	X, A, B, C, D, E, H, L
reg1	X, B, C, D, E, H, L
rp	XA, BC, DE, HL
rp1	BC, DE, HL
rp2	BC, DE
rp'	XA, BC, DE, HL, XA', BC', DE', HL'
rp'1	BC, DE, HL, XA', BC', DE', HL'
rpa	HL, HL+, HL-, DE, DL
rpa1	DE, DL
n4	4-bit immediate data or label
n8	8-bit immediate data or label
mem	8-bit immediate data or label ^{Note}
bit	2-bit immediate data or label
fmem	FB0H-FBFH/FF0H-FFFH immediate data or label
pmem	FC0H-FFFH immediate data or label
addr1	0000H-7F7FH immediate data or label
addr	0000H-3F7FH immediate data or label
caddr	12-bit immediate data or label
faddr	11-bit immediate data or label
taddr	20H-7FH immediate data (bit 0 = 0) or label
PORTn	PORT0-PORT15
IE _{xxx}	IEBT, IECS10, IET0, IETPG, IE0, IE1, IE2, IEKS, IEW, IE4
RBn	RB0-RB3
MBn	MB0, MB1, MB2, MB3, MB15

Note Only even addresses can be specified for 8-bit data processing.

(2) Legend

A	: A register, 4-bit accumulator
B	: B register, 4-bit accumulator
C	: C register, 4-bit accumulator
D	: D register, 4-bit accumulator
E	: E register, 4-bit accumulator
H	: H register, 4-bit accumulator
L	: L register, 4-bit accumulator
X	: X register, 4-bit accumulator
XA	: Register pair (XA), 8-bit accumulator
BC	: Register pair (BC), 8-bit accumulator
DE	: Register pair (DE), 8-bit accumulator
HL	: Register pair (HL), 8-bit accumulator
XA'	: Extended register pair (XA')
BC'	: Extended register pair (BC')
DE'	: Extended register pair (DE')
HL'	: Extended register pair (HL')
PC	: Program counter
SP	: Stack pointer
SBS	: Stack bank select register
CY	: Carry flag, bit accumulator
PSW	: Program status word
MBE	: Memory bank enable flag
RBE	: Register bank enable flag
PORTn	: Port n (n = 0 to 15)
IME	: Interrupt master enable flag
IPS	: Interrupt priority specification register
IE $\times\times\times$: Interrupt enable flag
RBS	: Register bank select register
MBS	: Memory bank select register
PCC	: Processor clock control register
.	: Address/bit delimiter
($\times\times$)	: Contents addressed by $\times\times$
$\times\times$ H	: Hexadecimal data

(3) Explanation of the symbols in the addressing area field

*1	MB = MBE•MBS (MBS = 0, 1, 2, 3, or 15)	
*2	MB = 0	
*3	MBE = 0: MB = 0 (00H-7FH) MB = 15 (80H-FFH) MBE = 1: MB = MBS (MBS = 0, 1, 2, 3, or 15)	
*4	MB = 15, fmem = FB0H-FBFH or FF0H-FFFH	
*5	MB = 15, pmem = FC0H-FFFH	
*6	addr = 0000H-3FFFH	
*7	addr = (Current PC) -15 to (Current PC) -1 or (Current PC) +2 to (Current PC) +16	
*8	caddr = 0000H-0FFFH (PC _{14,13,12} = 00B) or 1000H-1FFFH (PC _{14,13,12} = 01B) or 2000H-2FFFH (PC _{14,13,12} = 10B) or 3000H-3FFFH (PC _{14,13,12} = 11B) or 4000H-4FFFH (PC _{14,13,12} = 100B) or 5000H-5FFFH (PC _{14,13,12} = 101B) or 6000H-6FFFH (PC _{14,13,12} = 110B) or 7000H-7F7FH (PC _{14,13,12} = 111B)	
*9	faddr = 0000H-07FFH	
*10	taddr = 0020H-007FH	
*11	addr1 = 0000H-7F7FH	

- Remarks 1.** MB indicates an accessible memory bank.
2. For *2, MB is always 0 irrespective of MBE and MBS.
 3. For *4 and *5, MB is always 15 irrespective of MBE and MBS.
 4. *6 to *11 indicate each addressable area.

(4) Explanation of the machine cycle column

S represents the number of machine cycles required when a skip instruction with the skip function performs a skip operation. S assumes one of the following values:

- When no skip operation is performed : S = 0
- When a 1-byte instruction or 2-byte instruction is skipped: S = 1
- When a 3-byte instruction is skipped : S = 2

Caution The GETI instruction is skipped in one machine cycle.

One machine cycle is equal to one cycle (= tcy) of the CPU clock (Φ), and five types of times are available for selection according to the PCC and SCC settings. (See (3) in Section 4.2.)

Instruction	Mnemonic	Operand	Number of bytes	Machine cycle	Operation	Addressing area	Skip condition
Transfer	MOV	A,#n4	1	1	$A \leftarrow n4$		String effect A
		reg1,#n4	2	2	$reg1 \leftarrow n4$		
		XA,#n8	2	2	$XA \leftarrow n8$		String effect A
		HL,#n8	2	2	$HL \leftarrow n8$		String effect B
		rp2,#n8	2	2	$rp2 \leftarrow n8$		
		A,@HL	1	1	$A \leftarrow (HL)$	*1	
		A,@HL+	1	2 + S	$A \leftarrow (HL)$, then $L \leftarrow L + 1$	*1	L = 0
		A,@HL-	1	2 + S	$A \leftarrow (HL)$, then $L \leftarrow L - 1$	*1	L = FH
		A,@rpa1	1	1	$A \leftarrow (rpa1)$	*2	
		XA,@HL	2	2	$XA \leftarrow (HL)$	*1	
		@HL,A	1	1	$(HL) \leftarrow A$	*1	
		@HL,XA	2	2	$(HL) \leftarrow XA$	*1	
		A,mem	2	2	$A \leftarrow (mem)$	*3	
		XA,mem	2	2	$XA \leftarrow (mem)$	*3	
		mem,A	2	2	$(mem) \leftarrow A$	*3	
		mem,XA	2	2	$(mem) \leftarrow XA$	*3	
		A,reg	2	2	$A \leftarrow reg$		
		XA,rp'	2	2	$XA \leftarrow rp'$		
	reg1,A	2	2	$reg1 \leftarrow A$			
	rp'1,XA	2	2	$rp'1 \leftarrow XA$			
	XCH	A,@HL	1	1	$A \leftrightarrow (HL)$	*1	
		A,@HL+	1	2 + S	$A \leftrightarrow (HL)$, then $L \leftarrow L + 1$	*1	L = 0
		A,@HL-	1	2 + S	$A \leftrightarrow (HL)$, then $L \leftarrow L - 1$	*1	L = FH
		A,@rpa1	1	1	$A \leftrightarrow (rpa1)$	*2	
		XA,@HL	2	2	$XA \leftrightarrow (HL)$	*1	
		A,mem	2	2	$A \leftrightarrow (mem)$	*3	
		XA,mem	2	2	$XA \leftrightarrow (mem)$	*3	
		A,reg1	1	1	$A \leftrightarrow reg1$		
XA,rp'		2	2	$XA \leftrightarrow rp'$			
Table reference	MOVT	XA,@PCDE	1	3	$XA \leftarrow (PC_{14-8}+DE)_{ROM}$		
		XA,@PCXA	1	3	$XA \leftarrow (PC_{14-8}+XA)_{ROM}$		
		XA,@BCDE	1	3	$XA \leftarrow (BCDE)_{ROM}$	*11	
		XA,@BCXA	1	3	$XA \leftarrow (BCXA)_{ROM}$	*11	

Instruction	Mnemonic	Operand	Number of bytes	Machine cycle	Operation	Addressing area	Skip condition
Bit transfer	MOV1	CY, fmem.bit	2	2	$CY \leftarrow (\text{fmem.bit})$	*4	
		CY, pmem.@L	2	2	$CY \leftarrow (\text{pmem}_{7-2+L_{3-2}.bit(L_{1-0})})$	*5	
		CY, @H+mem.bit	2	2	$CY \leftarrow (\text{H+mem}_{3-0}.bit)$	*1	
		fmem.bit, CY	2	2	$(\text{fmem.bit}) \leftarrow CY$	*4	
		pmem.@L, CY	2	2	$(\text{pmem}_{7-2+L_{3-2}.bit(L_{1-0})}) \leftarrow CY$	*5	
		@H+mem.bit, CY	2	2	$(\text{H+mem}_{3-0}.bit) \leftarrow CY$	*1	
Arithmetic/logical	ADDS	A, #n4	1	1 + S	$A \leftarrow A + n4$		carry
		XA, #n8	2	2 + S	$XA \leftarrow XA + n8$		carry
		A, @HL	1	1 + S	$A \leftarrow A + (\text{HL})$	*1	carry
		XA, rp'	2	2 + S	$XA \leftarrow XA + rp'$		carry
		rp'1, XA	2	2 + S	$rp'1 \leftarrow rp'1 + XA$		carry
	ADDC	A, @HL	1	1	$A, CY \leftarrow A + (\text{HL}) + CY$	*1	
		XA, rp'	2	2	$XA, CY \leftarrow XA + rp' + CY$		
		rp'1, XA	2	2	$rp'1, CY \leftarrow rp'1 + XA + CY$		
	SUBS	A, @HL	1	1 + S	$A \leftarrow A - (\text{HL})$	*1	borrow
		XA, rp'	2	2 + S	$XA \leftarrow XA - rp'$		borrow
		rp'1, XA	2	2 + S	$rp'1 \leftarrow rp'1 - XA$		borrow
	SUBC	A, @HL	1	1	$A, CY \leftarrow A - (\text{HL}) - CY$	*1	
		XA, rp'	2	2	$XA, CY \leftarrow XA - rp' - CY$		
		rp'1, XA	2	2	$rp'1, CY \leftarrow rp'1 - XA - CY$		
	AND	A, #n4	2	2	$A \leftarrow A \wedge n4$		
		A, @HL	1	1	$A \leftarrow A \wedge (\text{HL})$	*1	
		XA, rp'	2	2	$XA \leftarrow XA \wedge rp'$		
		rp'1, XA	2	2	$rp'1 \leftarrow rp'1 \wedge XA$		
	OR	A, #n4	2	2	$A \leftarrow A \vee n4$		
		A, @HL	1	1	$A \leftarrow A \vee (\text{HL})$	*1	
		XA, rp'	2	2	$XA \leftarrow XA \vee rp'$		
		rp'1, XA	2	2	$rp'1 \leftarrow rp'1 \vee XA$		
	XOR	A, #n4	2	2	$A \leftarrow A \nabla n4$		
		A, @HL	1	1	$A \leftarrow A \nabla (\text{HL})$	*1	
XA, rp'		2	2	$XA \leftarrow XA \nabla rp'$			
rp'1, XA		2	2	$rp'1 \leftarrow rp'1 \nabla XA$			
Accumulator manipulation	RORC	A	1	1	$CY \leftarrow A_0, A_3 \leftarrow CY, A_{n-1} \leftarrow A_n$		
	NOT	A	2	2	$A \leftarrow \bar{A}$		

Instruction	Mnemonic	Operand	Number of bytes	Machine cycle	Operation	Addressing area	Skip condition
Increment/decrement	INCS	reg	1	1 + S	$reg \leftarrow reg + 1$		reg = 0
		rp1	1	1 + S	$rp1 \leftarrow rp1 + 1$		rp1 = 00H
		@HL	2	2 + S	$(HL) \leftarrow (HL) + 1$	*1	(HL) = 0
		mem	2	2 + S	$(mem) \leftarrow (mem) + 1$	*3	(mem) = 0
	DECS	reg	1	1 + S	$reg \leftarrow reg - 1$		reg = FH
		rp'	2	2 + S	$rp' \leftarrow rp' - 1$		rp' = FFH
Comparison	SKE	reg,#n4	2	2 + S	Skip if reg = n4		reg = n4
		@HL,#n4	2	2 + S	Skip if (HL) = n4	*1	(HL) = n4
		A,@HL	1	1 + S	Skip if A = (HL)	*1	A = (HL)
		XA,@HL	2	2 + S	Skip if XA = (HL)	*1	XA = (HL)
		A,reg	2	2 + S	Skip if A = reg		A = reg
		XA,rp'	2	2 + S	Skip if XA = rp'		XA = rp'
Carry flag manipulation	SET1	CY	1	1	$CY \leftarrow 1$		
	CLR1	CY	1	1	$CY \leftarrow 0$		
	SKT	CY	1	1 + S	Skip if CY = 1		CY = 1
	NOT1	CY	1	1	$CY \leftarrow \overline{CY}$		

Instruction	Mnemonic	Operand	Number of bytes	Machine cycle	Operation	Addressing area	Skip condition
Memory bit manipulation	SET1	mem.bit	2	2	(mem.bit) ← 1	*3	
		fmem.bit	2	2	(fmem.bit) ← 1	*4	
		pmem.@L	2	2	(pmem ₇₋₂ +L ₃₋₂ .bit(L ₁₋₀)) ← 1	*5	
		@H+mem.bit	2	2	(H+mem ₃₋₀ .bit) ← 1	*1	
	CLR1	mem.bit	2	2	(mem.bit) ← 0	*3	
		fmem.bit	2	2	(fmem.bit) ← 0	*4	
		pmem.@L	2	2	(pmem ₇₋₂ +L ₃₋₂ .bit(L ₁₋₀)) ← 0	*5	
		@H+mem.bit	2	2	(H+mem ₃₋₀ .bit) ← 0	*1	
	SKT	mem.bit	2	2 + S	Skip if (mem.bit) = 1	*3	(mem.bit) = 1
		fmem.bit	2	2 + S	Skip if (fmem.bit) = 1	*4	(fmem.bit) = 1
		pmem.@L	2	2 + S	Skip if (pmem ₇₋₂ +L ₃₋₂ .bit(L ₁₋₀)) = 1	*5	(pmem.@L) = 1
		@H+mem.bit	2	2 + S	Skip if (H+mem ₃₋₀ .bit) = 1	*1	(@H+mem.bit) = 1
	SKF	mem.bit	2	2 + S	Skip if (mem.bit) = 0	*3	(mem.bit) = 0
		fmem.bit	2	2 + S	Skip if (fmem.bit) = 0	*4	(fmem.bit) = 0
		pmem.@L	2	2 + S	Skip if (pmem ₇₋₂ +L ₃₋₂ .bit(L ₁₋₀)) = 0	*5	(pmem.@L) = 0
		@H+mem.bit	2	2 + S	Skip if (H+mem ₃₋₀ .bit) = 0	*1	(@H+mem.bit) = 0
	SKTCLR	fmem.bit	2	2 + S	Skip if (fmem.bit) = 1 and clear	*4	(fmem.bit) = 1
		pmem.@L	2	2 + S	Skip if (pmem ₇₋₂ + L ₃₋₂ .bit(L ₁₋₀)) = 1 and clear	*5	(pmem.@L) = 1
		@H+mem.bit	2	2 + S	Skip if (H+mem ₃₋₀ .bit) = 1 and clear	*1	(@H+mem.bit) = 1
	AND1	CY,fmem.bit	2	2	CY ← CY ∧ (fmem.bit)	*4	
		CY,pmem.@L	2	2	CY ← CY ∧ (pmem ₇₋₂ +L ₃₋₂ .bit(L ₁₋₀))	*5	
		CY,@H+mem.bit	2	2	CY ← CY ∧ (H+mem ₃₋₀ .bit)	*1	
	OR1	CY,fmem.bit	2	2	CY ← CY ∨ (fmem.bit)	*4	
		CY,pmem.@L	2	2	CY ← CY ∨ (pmem ₇₋₂ +L ₃₋₂ .bit(L ₁₋₀))	*5	
CY,@H+mem.bit		2	2	CY ← CY ∨ (H+mem ₃₋₀ .bit)	*1		
XOR1	CY,fmem.bit	2	2	CY ← CY ⊕ (fmem.bit)	*4		
	CY,pmem.@L	2	2	CY ← CY ⊕ (pmem ₇₋₂ +L ₃₋₂ .bit(L ₁₋₀))	*5		
	CY,@H+mem.bit	2	2	CY ← CY ⊕ (H+mem ₃₋₀ .bit)	*1		
Branch	BR	addr	—	—	PC ₁₄₋₀ ← addr1 (The assembler selects an appropriate instruction from the BR !addr, BRA !addr1, BR CB !caddr, and BR \$addr1 instructions.)	*11	
		\$addr 1	1	2	PC ₁₄₋₀ ← addr1	*7	
		!addr	3	3	PC ₁₄ ← 0, PC ₁₃₋₀ ← !addr	*6	
		PCDE	2	3	PC ₁₄₋₀ ← PC ₁₄₋₈ + DE		
		PCXA	2	3	PC ₁₄₋₀ ← PC ₁₄₋₈ + XA		
		BCDE	2	3	PC ₁₄₋₀ ← BCDE		
		BCXA	2	3	PC ₁₄₋₀ ← BCXA		
	BRA	!addr1	3	3	PC ₁₄₋₀ ← !addr1	*11	
	BRCB	!caddr	2	2	PC ₁₄₋₀ ← PC _{14,13,12} + caddr ₁₁₋₀	*8	

Instruction	Mnemonic	Operand	Number of bytes	Machine cycle	Operation	Addressing area	Skip condition
Subroutine stack control	CALL	!addr	3	4	(SP-5)(SP-6)(SP-3)(SP-4) ← PC ₁₄₋₀ (SP-2) ← x, x, MBE, RBE PC ₁₄ ← 0, PC ₁₃₋₀ ← addr, SP ← SP-6	*6	
	CALLA	!addr1	3	3	(SP-5)(SP-6)(SP-3)(SP-4) ← PC ₁₄₋₀ (SP-2) ← x, x, MBE, RBE PC ₁₄₋₀ ← addr1, SP ← SP-6	*11	
	CALLF	!faddr	2	3	(SP-5)(SP-6)(SP-3)(SP-4) ← PC ₁₄₋₀ (SP-2) ← x, x, MBE, RBE PC ₁₄₋₀ ← 0000, faddr, SP ← SP-6	*9	
	RET		1	3	x, x, MBE, RBE ← (SP+4) PC ₁₄₋₀ ← (SP+1)(SP)(SP+3)(SP+2) SP ← SP+6		
	RETS		1	3 + S	x, x, MBE, RBE ← (SP+4) PC ₁₄₋₀ ← (SP+1) (SP)(SP+3)(SP+2) SP ← SP+6 then skip unconditionally		Unconditionally
	RETI		1	3	x, PC _{14,13,12} ← (SP+1) PC ₁₁₋₀ ← (SP)(SP+3)(SP+2) PSW ← (SP+4)(SP+5), SP ← SP+6		
	PUSH	rp	1	1	(SP-1)(SP-2) ← rp, SP ← SP-2		
		BS	2	2	(SP-1) ← MBS, (SP-2) ← RBS, SP ← SP-2		
POP	rp	1	1	rp ← (SP+1)(SP), SP ← SP+2			
	BS	2	2	MBS ← (SP+1), RBS ← (SP), SP ← SP+2			
Interrupt control	EI		2	2	IME(IPS.3) ← 1		
		IE _{xxx}	2	2	IE _{xxx} ← 1		
	DI		2	2	IME(IPS.3) ← 0		
		IE _{xxx}	2	2	IE _{xxx} ← 0		
I/O	IN ^{Note}	A,PORT _n	2	2	A ← PORT _n		
		XA,PORT _n	2	2	XA ← PORT _{n+1} , PORT _n		
	OUT ^{Note}	PORT _n ,A	2	2	PORT _n ← A		
		PORT _n ,XA	2	2	PORT _{n+1} , PORT _n ← XA		
CPU control	HALT		2	2	Set HALT Mode (PCC.2 ← 1)		
	STOP		2	2	Set STOP Mode (PCC.3 ← 1)		
	NOP		1	1	No Operation		

Note MBE = 0, or MBE = 1 and MBS = 15 must be set when an IN/OUT instruction is executed.

Instruction	Mnemonic	Operand	Number of bytes	Machine cycle	Operation	Addressing area	Skip condition
Special	SEL	RBn	2	2	$RBS \leftarrow n$ (n=0-3)		
		MBn	2	2	$MBS \leftarrow n$ (n=0,1,2,3,15)		
	GET Note	taddr	1	3	<ul style="list-style-type: none"> For a TBR instruction $PC_{13-0} \leftarrow (taddr)_{5-0} + (taddr+1)$ $PC_{14} \leftarrow 0$ 	*10	
		4	<ul style="list-style-type: none"> For a TCALL instruction $(SP-5)(SP-6)(SP-3)(SP-4) \leftarrow PC_{14-0}$ $(SP-2) \leftarrow X, X, MBE, RBE$ $PC_{13-0} \leftarrow (taddr)_{5-0} + (taddr+1)$ $SP \leftarrow SP-6$ $PC_{14} \leftarrow 0$ 				
		3	<ul style="list-style-type: none"> For an instruction other than TBR and TCALL Executes the instruction in (taddr)(taddr+1). 	Depends upon the referenced instruction.			

★

Note The TBR and TCALL instructions are table definition assembler pseudo instructions of the GETI instructions.

8.3 INSTRUCTION CODES OF EACH INSTRUCTION

(1) Explanations of the symbols for the instruction codes

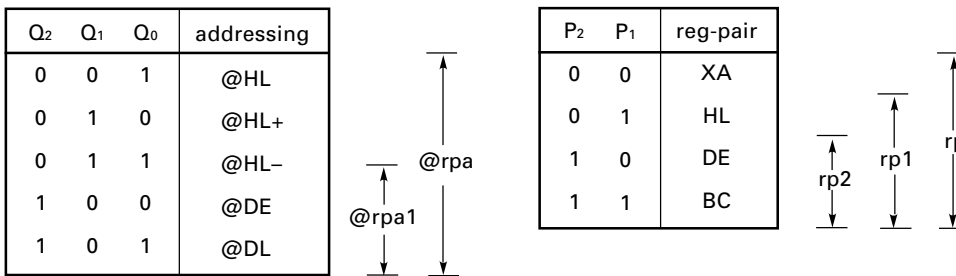
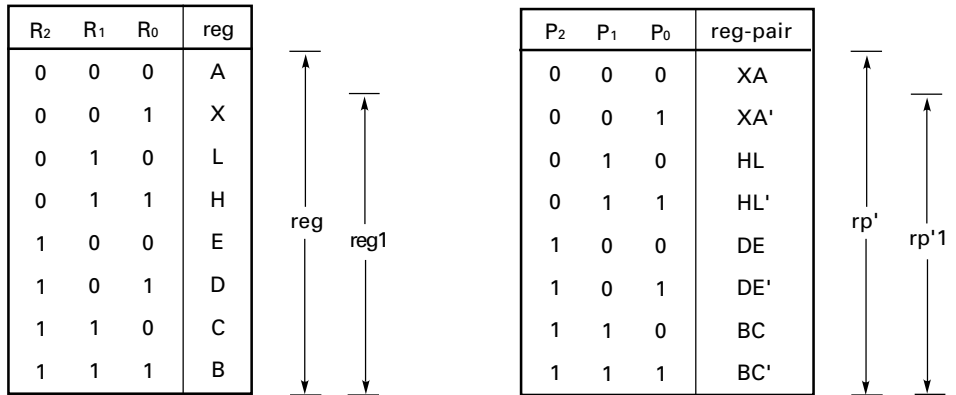

N ₅	N ₂	N ₁	N ₀	IE _{xxx}
0	0	0	0	IEBT
0	0	1	0	IEW
0	0	1	1	IETPG
0	1	0	0	IETO
0	1	0	1	IECS10
0	1	1	0	IE0
0	1	1	1	IE2
1	0	0	0	IE4
1	0	1	1	IEKS
1	1	1	0	IE1

- In : Immediate data for n4 or n8
- Dn: Immediate data for mem
- Bn: Immediate data for bit
- Nn: Immediate data for n or IE_{xxx}
- Tn: Immediate data for taddr × 1/2
- An: Immediate data for the relative address distance (2 to 16) for the branch destination address minus one
- Sn: Immediate data for the ones complement of the relative address distance (15 to 1) for the branch destination address

(2) Bit manipulation addressing instruction codes

*1 in the operand field indicates that there are three types of bit manipulation addressing, fmem.bit, pmem.@L, and @H+mem.bit.

The table below lists the second byte *2 of an instruction code corresponding to the above addressing.

*1	Second byte of instruction code								Accessible bits
fmem.bit	1	0	B ₁	B ₀	F ₃	F ₂	F ₁	F ₀	FB0H - FBFH manipulatable bits
	1	1	B ₁	B ₀	F ₃	F ₂	F ₁	F ₀	FF0H - FFFH manipulatable bits
pmem.@L	0	1	0	0	G ₃	G ₂	G ₁	G ₀	FC0H-FFFH manipulatable bits
@H+mem.bit	0	0	B ₁	B ₀	D ₃	D ₂	D ₁	D ₀	Manipulatable bits of accessible memory bank

Bn: Immediate data for bit

Fn: Immediate data for fmem (Low-order four bits of address)

Gn: Immediate data for pmem (Bits 2 to 5 of address)

Dn: Immediate data for mem (Low-order four bits of address)

Instruc- tion	Mnemonic	Operand	Instruction code		
			B ₁	B ₂	B ₃
Transfer	MOV	A, #n4	0 1 1 1 l ₃ l ₂ l ₁ l ₀		
		reg1, #n4	1 0 0 1 1 0 1 0	l ₃ l ₂ l ₁ l ₀ 1 R ₂ R ₁ R ₀	
		rp, #n8	1 0 0 0 1 P ₂ P ₁ 1	l ₇ l ₆ l ₅ l ₄ l ₃ l ₂ l ₁ l ₀	
		A, @rpa	1 1 1 0 0 0 Q ₂ Q ₁ Q ₀		
		XA, @HL	1 0 1 0 1 0 1 0	0 0 0 1 1 0 0 0	
		@HL, A	1 1 1 0 1 0 0 0		
		@HL, XA	1 0 1 0 1 0 1 0	0 0 0 1 0 0 0 0	
		A, mem	1 0 1 0 0 0 1 1	D ₇ D ₆ D ₅ D ₄ D ₃ D ₂ D ₁ D ₀	
		XA, mem	1 0 1 0 0 0 1 0	D ₇ D ₆ D ₅ D ₄ D ₃ D ₂ D ₁ 0	
		mem, A	1 0 0 1 0 0 1 1	D ₇ D ₆ D ₅ D ₄ D ₃ D ₂ D ₁ D ₀	
		mem, XA	1 0 0 1 0 0 1 0	D ₇ D ₆ D ₅ D ₄ D ₃ D ₂ D ₁ 0	
		A, reg	1 0 0 1 1 0 0 1	0 1 1 1 1 R ₂ R ₁ R ₀	
		XA, rp'	1 0 1 0 1 0 1 0	0 1 0 1 1 P ₂ P ₁ P ₀	
		reg1, A	1 0 0 1 1 0 0 1	0 1 1 1 0 R ₂ R ₁ R ₀	
	rp'1, XA	1 0 1 0 1 0 1 0	0 1 0 1 0 P ₂ P ₁ P ₀		
	XCH	A, @rpa	1 1 1 0 1 Q ₂ Q ₁ Q ₀		
		XA, @HL	1 0 1 0 1 0 1 0	0 0 0 1 0 0 0 1	
		A, mem	1 0 1 1 0 0 1 1	D ₇ D ₆ D ₅ D ₄ D ₃ D ₂ D ₁ D ₀	
		XA, mem	1 0 1 1 0 0 1 0	D ₇ D ₆ D ₅ D ₄ D ₃ D ₂ D ₁ 0	
		A, reg1	1 1 0 1 1 R ₂ R ₁ R ₀		
XA, rp'		1 0 1 0 1 0 1 0	0 1 0 0 0 P ₂ P ₁ P ₀		
Table reference	MOVT	XA, @PCDE	1 1 0 1 0 1 0 0		
		XA, @PCXA	1 1 0 1 0 0 0 0		
		XA, @BCDE	1 1 0 1 0 1 0 1		
		XA, @BCXA	1 1 0 1 0 0 0 1		
Bit transfer	MOV1	CY, *1	1 0 1 1 1 1 0 1	*2	
		*1, CY	1 0 0 1 1 0 1 1	*2	

Instruc- tion	Mnemonic	Operand	Instruction code		
			B ₁	B ₂	B ₃
Arithme- tic/logical	ADDS	A, #n4	0 1 1 0 l ₃ l ₂ l ₁ l ₀		
		XA, #n8	1 0 1 1 1 0 0 1	l ₇ l ₆ l ₅ l ₄ l ₃ l ₂ l ₁ l ₀	
		A, @HL	1 1 0 1 0 0 1 0		
		XA, rp'	1 0 1 0 1 0 1 0	1 1 0 0 1 P ₂ P ₁ P ₀	
		rp'1, XA	1 0 1 0 1 0 1 0	1 1 0 0 0 P ₂ P ₁ P ₀	
	ADDC	A, @HL	1 0 1 0 1 0 0 1		
		XA, rp'	1 0 1 0 1 0 1 0	1 1 0 1 1 P ₂ P ₁ P ₀	
		rp'1, XA	1 0 1 0 1 0 1 0	1 1 0 1 0 P ₂ P ₁ P ₀	
	SUBS	A, @HL	1 0 1 0 1 0 0 0		
		XA, rp'	1 0 1 0 1 0 1 0	1 1 1 0 1 P ₂ P ₁ P ₀	
		rp'1, XA	1 0 1 0 1 0 1 0	1 1 1 0 0 P ₂ P ₁ P ₀	
	SUBC	A, @HL	1 0 1 1 1 0 0 0		
		XA, rp'	1 0 1 0 1 0 1 0	1 1 1 1 1 P ₂ P ₁ P ₀	
		rp'1, XA	1 0 1 0 1 0 1 0	1 1 1 1 0 P ₂ P ₁ P ₀	
	AND	A, #n4	1 0 0 1 1 0 0 1	0 0 1 1 l ₃ l ₂ l ₁ l ₀	
		A, @HL	1 0 0 1 0 0 0 0		
		XA, rp'	1 0 1 0 1 0 1 0	1 0 0 1 1 P ₂ P ₁ P ₀	
		rp'1, XA	1 0 1 0 1 0 1 0	1 0 0 1 0 P ₂ P ₁ P ₀	
	OR	A, #n4	1 0 0 1 1 0 0 1	0 1 0 0 l ₃ l ₂ l ₁ l ₀	
		A, @HL	1 0 1 0 0 0 0 0		
XA, rp'		1 0 1 0 1 0 1 0	1 0 1 0 1 P ₂ P ₁ P ₀		
rp'1, XA		1 0 1 0 1 0 1 0	1 0 1 0 0 P ₂ P ₁ P ₀		
XOR	A, #n4	1 0 0 1 1 0 0 1	0 1 0 1 l ₃ l ₂ l ₁ l ₀		
	A, @HL	1 0 1 1 0 0 0 0			
	XA, rp'	1 0 1 0 1 0 1 0	1 0 1 1 1 P ₂ P ₁ P ₀		
	rp'1, XA	1 0 1 0 1 0 1 0	1 0 1 1 0 P ₂ P ₁ P ₀		
Accumu- lator man- ipulation	RORC	A	1 0 0 1 1 0 0 0		
	NOT	A	1 0 0 1 1 0 0 1	0 1 0 1 1 1 1 1	

Instruction	Mnemonic	Operand	Instruction code		
			B ₁	B ₂	B ₃
Increment/ decrement	INCS	reg	1 1 0 0 0 R ₂ R ₁ R ₀		
		rp1	1 0 0 0 1 P ₂ P ₁ 0		
		@HL	1 0 0 1 1 0 0 1	0 0 0 0 0 0 1 0	
		mem	1 0 0 0 0 0 1 0	D ₇ D ₆ D ₅ D ₄ D ₃ D ₂ D ₁ D ₀	
	DECS	reg	1 1 0 0 1 R ₂ R ₁ R ₀		
		rp'	1 0 1 0 1 0 1 0	0 1 1 0 1 P ₂ P ₁ P ₀	
Comparison	SKE	reg, #n4	1 0 0 1 1 0 1 0	l ₃ l ₂ l ₁ l ₀ 0 R ₂ R ₁ R ₀	
		@HL, #n4	1 0 0 1 1 0 0 1	0 1 1 0 l ₃ l ₂ l ₁ l ₀	
		A, @HL	1 0 0 0 0 0 0 0		
		XA, @HL	1 0 1 0 1 0 1 0	0 0 0 1 1 0 0 1	
		A, reg	1 0 0 1 1 0 0 1	0 0 0 0 1 R ₂ R ₁ R ₀	
		XA, rp'	1 0 1 0 1 0 1 0	0 1 0 0 1 P ₂ P ₁ P ₀	
Carry flag manipulation	SET1	CY	1 1 1 0 0 1 1 1		
	CLR1	CY	1 1 1 0 0 1 1 0		
	SKT	CY	1 1 0 1 0 1 1 1		
	NOT1	CY	1 1 0 1 0 1 1 0		
Memory bit manipulation	SET1	mem.bit	1 0 B ₁ B ₀ 0 1 0 1	D ₇ D ₆ D ₅ D ₄ D ₃ D ₂ D ₁ D ₀	
		*1	1 0 0 1 1 1 0 1	*2	
	CLR1	mem.bit	1 0 B ₁ B ₀ 0 1 0 0	D ₇ D ₆ D ₅ D ₄ D ₃ D ₂ D ₁ D ₀	
		*1	1 0 0 1 1 1 0 0	*2	
	SKT	mem.bit	1 0 B ₁ B ₀ 0 1 1 1	D ₇ D ₆ D ₅ D ₄ D ₃ D ₂ D ₁ D ₀	
		*1	1 0 1 1 1 1 1 1	*2	
	SKF	mem.bit	1 0 B ₁ B ₀ 0 1 1 0	D ₇ D ₆ D ₅ D ₄ D ₃ D ₂ D ₁ D ₀	
		*1	1 0 1 1 1 1 1 0	*2	
	SKTCLR	*1	1 0 0 1 1 1 1 1	*2	
	AND1	CY, *1	1 0 1 0 1 1 0 0	*2	
	OR1	CY, *1	1 0 1 0 1 1 1 0	*2	
	XOR1	CY, *1	1 0 1 1 1 1 0 0	*2	

Instruction	Mnemonic	Operand	Instruction code		
			B ₁	B ₂	B ₃
Branch	BR	laddr	1 0 1 0 1 0 1 1	0 0 ←————→	addr —————→
		\$addr1 (+16) to (+2)	0 0 0 0 A ₃ A ₂ A ₁ A ₀		
		(-1) to (-15)	1 1 1 1 S ₃ S ₂ S ₁ S ₀		
		PCDE	1 0 0 1 1 0 0 1	0 0 0 0 0 1 0 0	
		PCXA	1 0 0 1 1 0 0 1	0 0 0 0 0 0 0 0	
		BCDE	1 0 0 1 1 0 0 1	0 0 0 0 0 1 0 1	
		BCXA	1 0 0 1 1 0 0 1	0 0 0 0 0 0 0 1	
	BRA	laddr1	1 0 1 1 1 0 1 0	0 ←————→	addr1 —————→
BRCB	lcaddr	0 1 0 1 ←————→	caddr —————→		
Subrou- tine stack control	CALL	laddr	1 0 1 0 1 0 1 1	0 1 ←————→	addr —————→
	CALLA	laddr1	1 0 1 1 1 0 1 1	0 ←————→	addr1 —————→
	CALLF	lfaddr	0 1 0 0 0 ←————→	faddr —————→	
	RET		1 1 1 0 1 1 1 0		
	RETS		1 1 1 0 0 0 0 0		
	RETI		1 1 1 0 1 1 1 1		
	PUSH	rp	0 1 0 0 1 P ₂ P ₁ 1		
		BS	1 0 0 1 1 0 0 1	0 0 0 0 0 1 1 1	
	POP	rp	0 1 0 0 1 P ₂ P ₁ 0		
BS		1 0 0 1 1 0 0 1	0 0 0 0 0 1 1 0		
I/O	IN	A, PORT _n	1 0 1 0 0 0 1 1	1 1 1 1 N ₃ N ₂ N ₁ N ₀	
		XA, PORT _n	1 0 1 0 0 0 1 0	1 1 1 1 N ₃ N ₂ N ₁ N ₀	
	OUT	PORT _n , A	1 0 0 1 0 0 1 1	1 1 1 1 N ₃ N ₂ N ₁ N ₀	
		PORT _n , XA	1 0 0 1 0 0 1 0	1 1 1 1 N ₃ N ₂ N ₁ N ₀	
Interrupt control	EI		1 0 0 1 1 1 0 1	1 0 1 1 0 0 1 0	
		IE _{xxx}	1 0 0 1 1 1 0 1	1 0 N ₅ 1 1 N ₂ N ₁ N ₀	
	DI		1 0 0 1 1 1 0 0	1 0 1 1 0 0 1 0	
		IE _{xxx}	1 0 0 1 1 1 0 0	1 0 N ₅ 1 1 N ₂ N ₁ N ₀	
CPU control	HALT		1 0 0 1 1 1 0 1	1 0 1 0 0 0 1 1	
	STOP		1 0 0 1 1 1 0 1	1 0 1 1 0 0 1 1	
	NOP		0 1 1 0 0 0 0 0		
Special	SEL	RB _n	1 0 0 1 1 0 0 1	0 0 1 0 0 0 N ₁ N ₀	
		MB _n	1 0 0 1 1 0 0 1	0 0 0 1 N ₃ N ₂ N ₁ N ₀	
	GETI	taddr	0 0 T ₅ T ₄ T ₃ T ₂ T ₁ T ₀		

★

9. SPECIFICATION OF MASK OPTIONS

The μPD75238 provides the following mask options, which enable specifying whether to incorporate the elements below:

Pin	Mask option
P40-P43	Allows pull-up resistor to be contained bit by bit.
P50-P53	
P70-P73	Allows pull-down resistor to be contained bit by bit.
S0/P120-S3/P123	Allows pull-down resistor to be contained to V _{LOAD} bit by bit.
S4/P130-S7/P133	
S8/P140, S9/P141	
S10/T15/P142, S11/T14/P143	
S12/T13/P150/PH0-S15/T10/P153/PH3	
S16/P100-S19/P103	Allows pull-down resistor ^{Note} to be contained to V _{LOAD} or V _{SS} bit by bit.
S20/P110-S23/P113	
XT1, XT2	Allows feed-back resistor of the subsystem clock oscillator to be deleted.

Note Select whether to incorporate the pull-down resistors in V_{LOAD} or V_{SS} in unit of eight bits.

Caution In systems without using subsystem clock, power consumption in STOP mode can be more reduced by deleting feed-back resistor of the oscillator.

10. APPLICATION BLOCK DIAGRAM

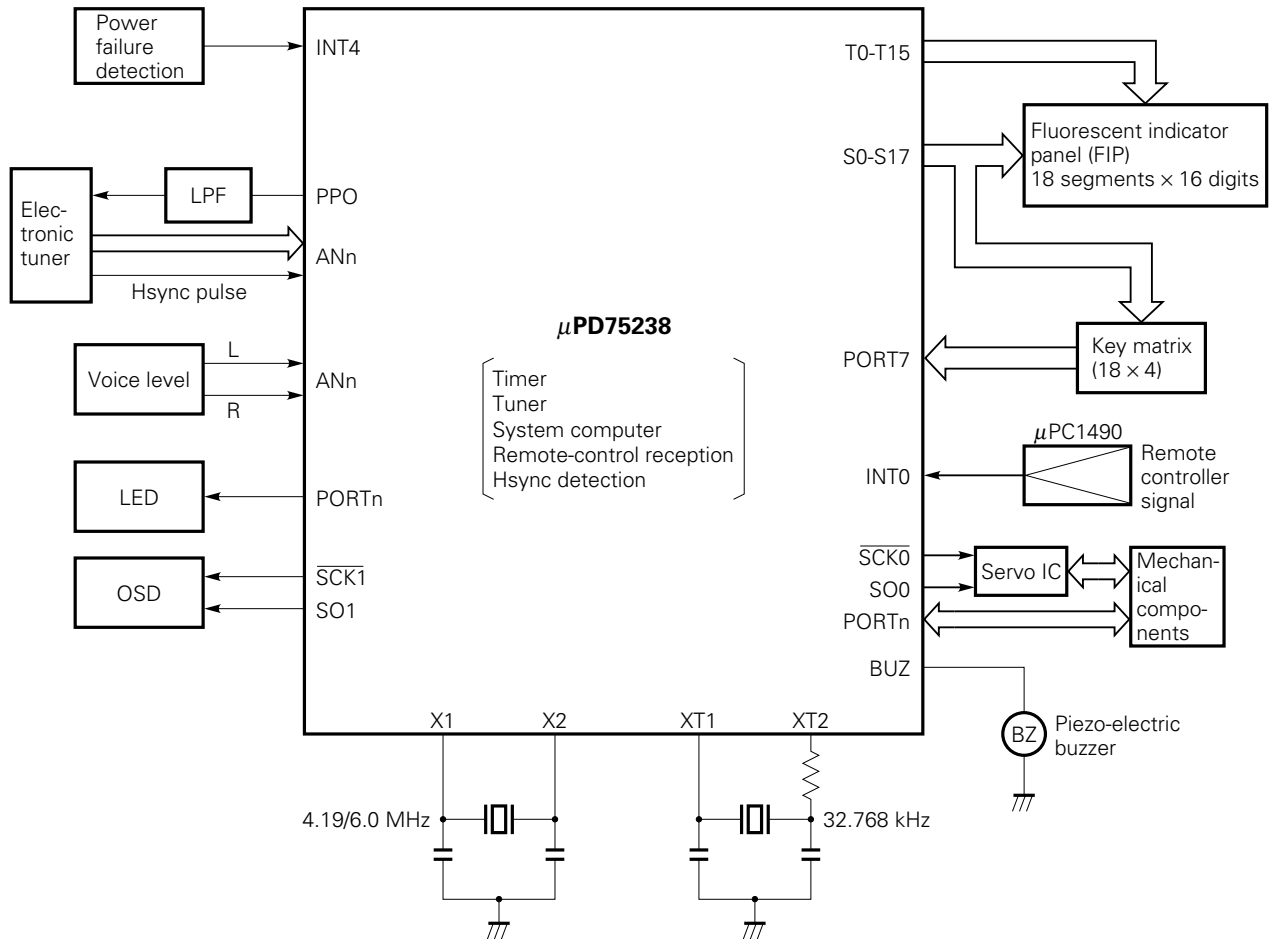

Remark LPF : Low pass filter
 OSD : On screen display
 Hsync: Horizontal synchronous

11. ELECTRICAL CHARACTERISTICS

ABSOLUTE MAXIMUM RATINGS (T_a = 25 °C)

Parameter	Symbol	Conditions		Rating	Unit
Supply voltage	V _{DD}			-0.3 to +7.0	V
	V _{LOAD}			V _{DD} - 40 to V _{DD} + 0.3	V
Input voltage	V _{I1}	Ports other than ports 4 and 5		-0.3 to V _{DD} + 0.3	V
	V _{I2}	Ports 4 and 5	Built-in pull-up resistor	-0.3 to V _{DD} + 0.3	V
			Open drain	-0.3 to +11	V
Output voltage	V _O	Pins other than display output pins		-0.3 to V _{DD} + 0.3	V
	V _{OD}	Display output pins		V _{DD} - 40 to V _{DD} + 0.3	V
High-level output current	I _{OH}	One of pins other than display output pins		-15	mA
		One pin of S0 to S9 and S16 to S23		-15	mA
		One pin of T0 to T15		-30	mA
		All pins other than display output pins		-30	mA
		All display output pins		-120	mA
Low-level output current	I _{OL}	Each pin	Peak value	30	mA
			rms	15	mA
		Total of all pins of ports 0, 2, 3, and 4	Peak value	100	mA
			rms	60	mA
		Total of all pins of ports 5 to 8	Peak value	100	mA
			rms	60	mA
Total power dissipation	P _T	Plastic QFP	(T _a = -40 to +70 °C)	700	mW
			(T _a = -40 to +85 °C)	510	mW
Operating temperature	T _{opt}			-40 to +85	°C
Storage temperature	T _{stg}			-65 to +150	°C

RANGE OF SUPPLY VOLTAGE (T_a = -40 to +85 °C)

Parameter	Min.	Max.	Unit	Conditions
CPU ^{Note 1}	Note 2	6.0	V	
Display controller	4.5	6.0	V	
Timer/pulse generator	4.5	6.0	V	
Hardware other than the above ^{Note 1}	2.7	6.0	V	

- Notes**
- The CPU does not include the system clock oscillator, the display controller, and the timer/pulse generator.
 - The range of the supply voltage at which the CPU can operate varies according to the cycle time. See the item of AC characteristics.

CHARACTERISTICS OF THE MAIN SYSTEM CLOCK OSCILLATOR (T_a = -40 to +85 °C, V_{DD} = 2.7 to 6.0 V)

Resonator	Recommended constant	Parameter	Min.	Typ.	Max.	Unit	Conditions
Ceramic resonator		Oscillator frequency (f _x) ^{Note 1}	2.0		6.2	MHz	V _{DD} = oscillation voltage range
		Oscillation stability time ^{Note 2}			4	ms	After V _{DD} reaches Min. of the oscillation voltage range
Crystal resonator		Oscillator frequency (f _x) ^{Note 1}	2.0	4.19	6.2	MHz	
		Oscillation stability time ^{Note 2}			10	ms	V _{DD} = 4.5 to 6.0 V
					30	ms	
External clock		X1 input frequency (f _x) ^{Note 1}	2.0		6.2	MHz	
		X1 input high/low level width (t _{xH} , t _{xL})	81		250	ns	

- Notes**
- The oscillator frequency and input frequency indicate only the oscillator characteristics. See the item of AC characteristics for the instruction execution time.
 - The oscillation stability time means the time required for the oscillation to stabilize after V_{DD} is applied or after the STOP mode is released.

CHARACTERISTICS OF THE SUBSYSTEM CLOCK OSCILLATOR (T_a = -40 to +85 °C, V_{DD} = 2.7 to 6.0 V)

Resonator	Recommended constant	Parameter	Min.	Typ.	Max.	Unit	Conditions
Crystal resonator		Oscillator frequency (f _{XT}) ^{Note 1}	32	32.768	35	kHz	
		Oscillation stability time ^{Note 2}			1.0	2	s
					10	s	
External clock		XT1 input frequency (f _{XT}) ^{Note 1}	32		100	kHz	
		XT1 input high/low level width (t _{xTH} , t _{xTL})	5		15	μs	

- Notes**
- The oscillator frequency and input frequency indicate only the oscillator characteristics. See the item of AC characteristics for the instruction execution time.
 - The oscillation stability time means the time required for the oscillation to stabilize after V_{DD} is applied or after the STOP mode is released.

CAPACITANCE (T_a = 25 °C, V_{DD} = 0 V)

Parameter	Symbol	Min.	Typ.	Max.	Unit	Conditions
Input capacitance	C _i			15	pF	f = 1 MHz 0 V for pins other than pins to be measured
Output capacitance (Other than display output)	C _o			15	pF	
I/O capacitance	C _{io}			15	pF	
Output capacitance (Display output)	C _o			35	pF	

DC CHARACTERISTICS (T_a = -40 to +85 °C, V_{DD} = 2.7 to 6.0 V)

Parameter	Symbol	Min.	Typ.	Max.	Unit	Conditions		
High-level input voltage	V _{IH1}	0.7V _{DD}		V _{DD}	V	Other than ports 0, 1, 4, 5, and 7, $\overline{\text{RESET}}$, P81, P83, X1, X2, and XT1		
	V _{IH2}	0.8V _{DD}		V _{DD}	V	Ports 0 and 1, $\overline{\text{RESET}}$, P81, and P83		
	V _{IH3}	V _{DD} - 0.4		V _{DD}	V	X1, X2, and XT1		
	V _{IH4}	0.65V _{DD}		V _{DD}	V	Port 7	V _{DD} = 4.5 to 6.0 V	
		0.7V _{DD}		V _{DD}	V			
	V _{IH5}	0.7V _{DD}		V _{DD}	V	Ports 4 and 5	Built-in pull-up resistor	
0.7V _{DD}			10	V	Open drain			
Low-level input voltage	V _{IL1}	0		0.3V _{DD}	V	Other than ports 0 and 1, $\overline{\text{RESET}}$, P81, P83, X1, X2, and XT1		
	V _{IL2}	0		0.2V _{DD}	V	Ports 0 and 1, $\overline{\text{RESET}}$, P81, and P83		
	V _{IL3}	0		0.4	V	X1, X2, and XT1		
High-level output voltage	V _{OH}	V _{DD} - 1.0			V	All output pins (excl. ports 4 and 5, and P03)	V _{DD} = 4.5 to 6.0 V	I _{OH} = -1 mA
		V _{DD} - 0.5			V		V _{DD} = 2.7 to 6.0 V	I _{OH} = -100 μA
Low-level output voltage	V _{OL}		0.4	2.0	V	Ports 3, 4, and 5	V _{DD} = 4.5 to 6.0 V	I _{OL} = 15 mA
				0.4	V	All output pins	V _{DD} = 4.5 to 6.0 V	I _{OL} = 1.6 mA
				0.5	V		V _{DD} = 2.7 to 6.0 V	I _{OL} = 400 μA
				0.2V _{DD}	V	SB0 and SB1	Open drain pull-up resistor: 1 kΩ or more	
High-level input leakage current	I _{LIH1}			3	μA	Other than X1, X2, XT1, Ports 4 and 5	V _{IN} = V _{DD}	
	I _{LIH2}			20	μA	X1, X2, and XT1		
	I _{LIH3}			20	μA	Ports 4 and 5	V _{IN} = 10 V (open drain)	
Low-level input leakage current	I _{LIL1}			-3	μA	Other than X1, X2, and XT1	V _{IN} = 0 V	
	I _{LIL2}			-20	μA	X1, X2, and XT1		
High-level output leakage current	I _{LOH1}			3	μA	Other than ports 4 and 5	V _{OUT} = V _{DD}	
	I _{LOH2}			20	μA	Ports 4 and 5	V _{OUT} = 10 V (open drain)	
Low-level output leakage current	I _{LOL1}			-3	μA	Other than display output	V _{OUT} = 0 V	
	I _{LOL2}			-10	μA	Display output	V _{OUT} = V _{LOAD} = V _{DD} - 35 V	
Display output current	I _{OD}	-3	-5.5		mA	S0 to S9, S16 to S23	V _{DD} = 4.5 to 6.0 V	
		-15	-22		mA	T0 to T15	V _{OD} = V _{DD} - 2 V	
Built-in pull-down resistor (mask option)	R _{P7}	20	80	200	kΩ	Port 7	V _{DD} = 4.5 to 6.0 V	
		20		1000	kΩ		V _{IN} = V _{DD}	
	R _L	25	50	135	kΩ	Display output	V _{OD} - V _{LOAD} = 35 V	
Built-in pull-up resistor	R _{V1}	15	40	80	kΩ	Ports 0, 1, 2, 3, and 6 (excl. P00)	V _{DD} = 5 V ± 10 %	
		30		300	kΩ		V _{IN} = 0 V	V _{DD} = 3 V ± 10 %
	R _{V2}	15	40	70	kΩ	Ports 4 and 5	V _{DD} = 5 V ± 10 %	
		10		60	kΩ		V _{OUT} = V _{DD} - 2.0 V	V _{DD} = 3 V ± 10 %

DC CHARACTERISTICS (T_a = -40 to +85 °C, V_{DD} = 2.7 to 6.0 V)

Parameter	Symbol	Min.	Typ.	Max.	Unit	Conditions		
Power supply current Note 1	I _{DD1}		4.5	13.5	mA	6.0 MHz crystal resonance	Operation mode	V _{DD} = 5 V ±10 % Note 2
			0.6	1.8	mA			V _{DD} = 3 V ±10 % Note 3
	I _{DD2}		600	1800	μA	C1 = C2 = 22 pF Note 4	HALT mode	V _{DD} = 5 V ±10 %
			200	600	μA			V _{DD} = 3 V ±10 %
	I _{DD1}		3	9	mA	4.19 MHz crystal resonance	Operation mode	V _{DD} = 5 V ±10 % Note 2
			0.5	1.5	mA			V _{DD} = 3 V ±10 % Note 3
	I _{DD2}		600	1800	μA	C1 = C2 = 22 pF Note 4	HALT mode	V _{DD} = 5 V ±10 %
			200	600	μA			V _{DD} = 3 V ±10 %
	I _{DD3}		40	120	μA	32 kHz Note 5 crystal resonance	Operation mode	V _{DD} = 3 V ±10 %
	I _{DD4}		5	15	μA		HALT mode	V _{DD} = 3 V ±10 %
I _{DD5}		0.5	20	μA	XT1 = 0 V STOP mode	V _{DD} = 5 V ±10 %		
		0.3	10	μA		V _{DD} = 3 V ±10 %		
			5	μA		T _a = 25 °C		

- Notes**
- This current excludes the current which flows through the built-in pull-down or pull-up resistors.
 - Value when the processor clock control register (PCC) is set to 0011 and the μPD75238 is operated in the high-speed mode
 - Value when the PCC is set to 0000 and the μPD75238 is operated in the low-speed mode
 - This value applies also when the subsystem clock oscillates.
 - This value applies when the system clock control resistor (SCC) is set to 1001 to stop the main system clock pulse and to start the subsystem clock pulse.

A/D CONVERTER CHARACTERISTICS (T_a = -40 to +85 °C, V_{DD} = 2.7 to 6.0 V, AV_{SS} = V_{SS} = 0 V, AV_{DD} = V_{DD})

Parameter	Symbol	Min.	Typ.	Max.	Unit	Conditions	
Resolution		8	8	8	bit		
Absolute accuracy Note 1				±1.5	LSB	2.5 V ≤ AV _{REF} ≤ AV _{DD}	-10 ≤ T _a ≤ +85 °C
				±2.0			-40 ≤ T _a < -10 °C
Conversion time	t _{CONV}			168/f _X	μs	Note 2	
Sampling time	t _{SAMP}			44/f _X	μs	Note 3	
Analog input voltage	V _{IAN}	AV _{SS}		AV _{REF}	V		
Analog input impedance	R _{AN}		1000		MΩ		
AV _{REF} current	I _{AREF}		1.0	2.0	mA		

- Notes**
- Absolute accuracy excluding quantization error (±1/2 LSB)
 - Time from the execution of a conversion start instruction till EOC = 1 (28.0 μs at f_X = 6.0 MHz, 40.1 μs at f_X = 4.19 MHz)
 - Time from the execution of a conversion start instruction till the end of sampling (7.33 μs at f_X = 6.0 MHz, 10.5 μs at f_X = 4.19 MHz)



AC CHARACTERISTICS (T_a = -40 to +85 °C, V_{DD} = 2.7 to 6.0 V)

(1) Basic operation

Parameter	Symbol	Min.	Typ.	Max.	Unit	Conditions
CPU clock cycle time (minimum instruction execution time) ^{Note 1}	t _{cy}	0.67		64	μs	Operated by main system clock pulse V _{DD} = 4.5 to 6.0 V
		2.6		64	μs	
		114	122	125	μs	Operated by subsystem clock pulse
TIO input frequency	f _{TI}	0		1	MHz	V _{DD} = 4.5 to 6.0 V
		0		275	kHz	
TIO input high/low level width	t _{TIH} ,	0.48			μs	V _{DD} = 4.5 to 6.0 V
	t _{TIL}	1.8			μs	
Interrupt input high/low level width	t _{INTH} ,	Note 2			μs	INT0
	t _{INTL}		10		μs	INT1, INT2, and INT4
RESET low level width	t _{RSL}	10			μs	

- Notes 1.** The cycle time of CPU clock (Φ) depends on the connected resonator frequency, the system clock control register (SCC), and the processor clock control register (PCC). The figure on the next page shows the cycle time t_{cy} characteristics for the supply voltage V_{DD} during main system clock operation.
- 2.** This value becomes 2t_{cy} or 128/f_x according to the setting of the interrupt mode register (IM0).

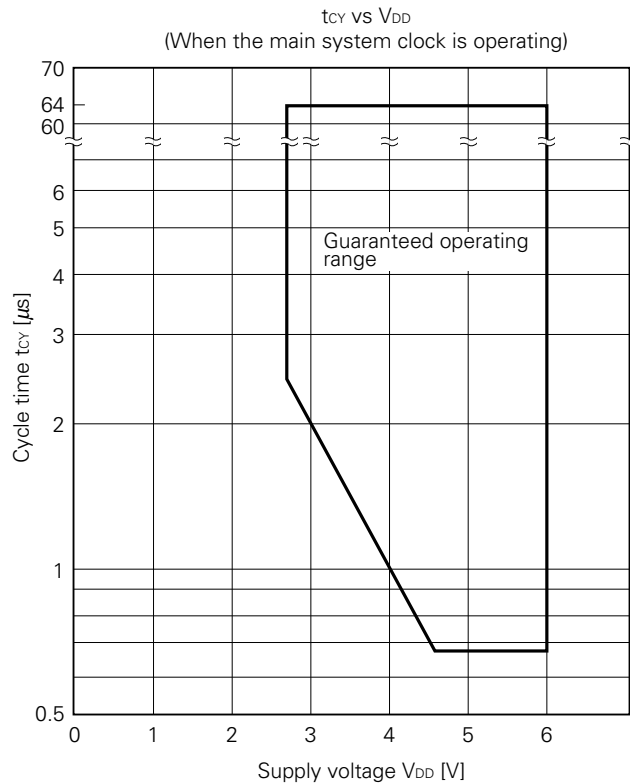

(2) Serial transfer operation

(a) Two-wire and three-wire serial I/O modes ($\overline{\text{SCK}}$... Internal clock output):

Parameter	Symbol	Min.	Typ.	Max.	Unit	Conditions	
$\overline{\text{SCK}}$ cycle time	t_{KCY1}	1340			ns	$V_{\text{DD}} = 4.5 \text{ to } 6.0 \text{ V}$	$f_x = 6.0 \text{ MHz}$
		1600			ns		$f_x = 4.19 \text{ MHz}$
		2680			ns		$f_x = 6.0 \text{ MHz}$
		3800			ns		$f_x = 4.19 \text{ MHz}$
$\overline{\text{SCK}}$ high/low level width	t_{KL1}	$(t_{\text{KCY}}/2) - 50$			ns	$V_{\text{DD}} = 4.5 \text{ to } 6.0 \text{ V}$	
	t_{KH1}	$(t_{\text{KCY}}/2) - 150$			ns		
SI setup time (referred to $\overline{\text{SCK}}\uparrow$)	t_{SIK1}	150			ns		
SI hold time (referred to $\overline{\text{SCK}}\uparrow$)	t_{KSI1}	400			ns		
$\overline{\text{SCK}}\downarrow \rightarrow \text{SO}$ output delay time	t_{KSO1}			250	ns	$R_L = 1 \text{ k}\Omega,$ $C_L = 100 \text{ pF}$ Note	$V_{\text{DD}} = 4.5 \text{ to } 6.0 \text{ V}$
				1000	ns		

Note R_L and C_L are the resistance and capacitance of the SO output line load respectively.

(b) Two-wire and three-wire serial I/O modes ($\overline{\text{SCK}}$... External clock input):

Parameter	Symbol	Min.	Typ.	Max.	Unit	Conditions	
$\overline{\text{SCK}}$ cycle time	t_{KCY2}	800			ns	$V_{\text{DD}} = 4.5 \text{ to } 6.0 \text{ V}$	
		3200			ns		
$\overline{\text{SCK}}$ high/low level width	t_{KL2}	400			ns	$V_{\text{DD}} = 4.5 \text{ to } 6.0 \text{ V}$	
	t_{KH2}	1600			ns		
SI setup time (referred to $\overline{\text{SCK}}\uparrow$)	t_{SIK2}	100			ns		
SI hold time (referred to $\overline{\text{SCK}}\uparrow$)	t_{KSI2}	400			ns		
$\overline{\text{SCK}}\downarrow \rightarrow \text{SO}$ output delay time	t_{KSO2}			300	ns	$R_L = 1 \text{ k}\Omega,$ $C_L = 100 \text{ pF}$ Note	$V_{\text{DD}} = 4.5 \text{ to } 6.0 \text{ V}$
				1000	ns		

Note R_L and C_L are the resistance and capacitance of the SO output line load respectively.

(c) SBI mode ($\overline{\text{SCK}}$... Internal clock output (master)):

Parameter	Symbol	Min.	Typ.	Max.	Unit	Conditions	
$\overline{\text{SCK}}$ cycle time	t_{KCY3}	1340			ns	$V_{\text{DD}} = 4.5 \text{ to } 6.0 \text{ V}$	$f_x = 6.0 \text{ MHz}$
		1600			ns		$f_x = 4.19 \text{ MHz}$
		2680			ns		$f_x = 6.0 \text{ MHz}$
		3800			ns		$f_x = 4.19 \text{ MHz}$
$\overline{\text{SCK}}$ high/low level width	t_{KL3}	$t_{\text{KCY}}/2 - 50$			ns	$V_{\text{DD}} = 4.5 \text{ to } 6.0 \text{ V}$	
	t_{KH3}	$t_{\text{KCY}}/2 - 150$			ns		
SB0/SB1 setup time (referred to $\overline{\text{SCK}}\uparrow$)	t_{SIK3}	150			ns		
SB0/SB1 hold time (referred to $\overline{\text{SCK}}\uparrow$)	t_{SI3}	$t_{\text{KCY}}/2$			ns		
$\overline{\text{SCK}}\downarrow \rightarrow \text{SB0/SB1}$ output delay time	t_{KSO3}	0		250	ns	$R_L = 1 \text{ k}\Omega$, $C_L = 100 \text{ pF}$ ^{Note}	$V_{\text{DD}} = 4.5 \text{ to } 6.0 \text{ V}$
		0		1000	ns		
$\overline{\text{SCK}}\uparrow \rightarrow \text{SB0/SB1}\downarrow$	t_{KSB}	t_{KCY}			ns		
$\text{SB0/SB1}\downarrow \rightarrow \overline{\text{SCK}}$	t_{SBK}	t_{KCY}			ns		
SB0/SB1 low level width	t_{SBL}	t_{KCY}			ns		
SB0/SB1 high level width	t_{SBH}	t_{KCY}			ns		

Note R_L and C_L are the resistance and capacitance of the SO output line load respectively.

(d) SBI mode ($\overline{\text{SCK}}$... External clock input (slave)):

Parameter	Symbol	Min.	Typ.	Max.	Unit	Conditions	
$\overline{\text{SCK}}$ cycle time	t_{KCY4}	800			ns	$V_{\text{DD}} = 4.5 \text{ to } 6.0 \text{ V}$	
		3200			ns		
$\overline{\text{SCK}}$ high/low level width	t_{KL4}	400			ns	$V_{\text{DD}} = 4.5 \text{ to } 6.0 \text{ V}$	
	t_{KH4}	1600			ns		
SB0/SB1 setup time (referred to $\overline{\text{SCK}}\uparrow$)	t_{SIK4}	100			ns		
SB0/SB1 hold time (referred to $\overline{\text{SCK}}\uparrow$)	t_{SI4}	$t_{\text{KCY}}/2$			ns		
$\overline{\text{SCK}}\downarrow \rightarrow \text{SB0/SB1}$ output delay time	t_{KSO4}	0		300	ns	$R_L = 1 \text{ k}\Omega$, $C_L = 100 \text{ pF}$ ^{Note}	$V_{\text{DD}} = 4.5 \text{ to } 6.0 \text{ V}$
		0		1000	ns		
$\overline{\text{SCK}}\uparrow \rightarrow \text{SB0/SB1}\downarrow$	t_{KSB}	t_{KCY}			ns		
$\text{SB0/SB1}\downarrow \rightarrow \overline{\text{SCK}}\downarrow$	t_{SBK}	t_{KCY}			ns		
SB0/SB1 low level width	t_{SBL}	t_{KCY}			ns		
SB0/SB1 high level width	t_{SBH}	t_{KCY}			ns		

Note R_L and C_L are the resistance and capacitance of the SO output line load respectively.

AC Timing Measurement Points (Excluding X1 and XT1 Inputs)

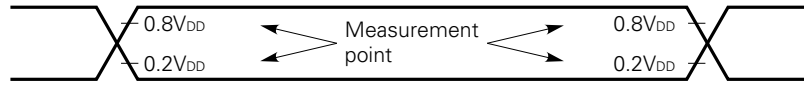

Clock Timing

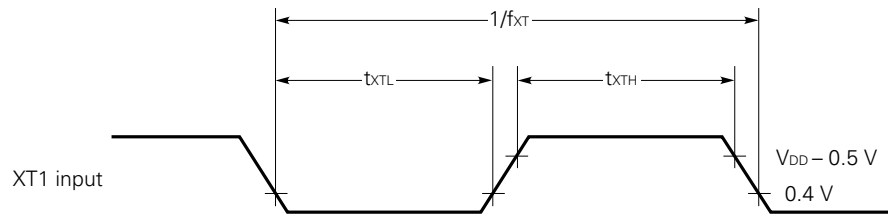
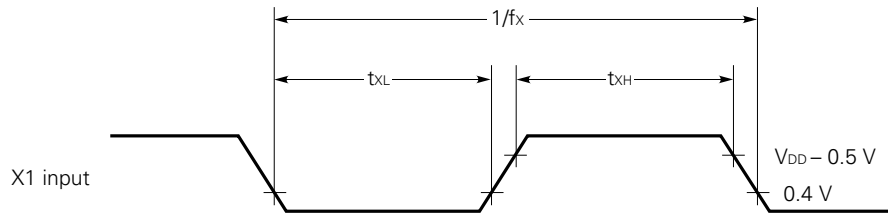

T10 Timing

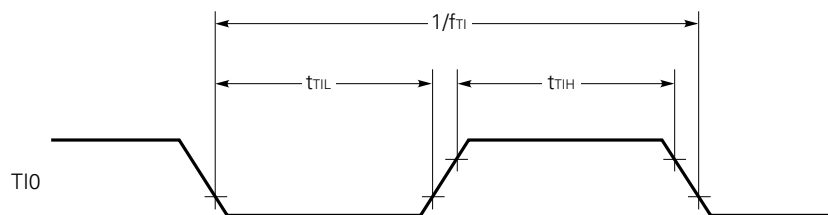

Serial Transfer Timing

Three-wire serial I/O mode:

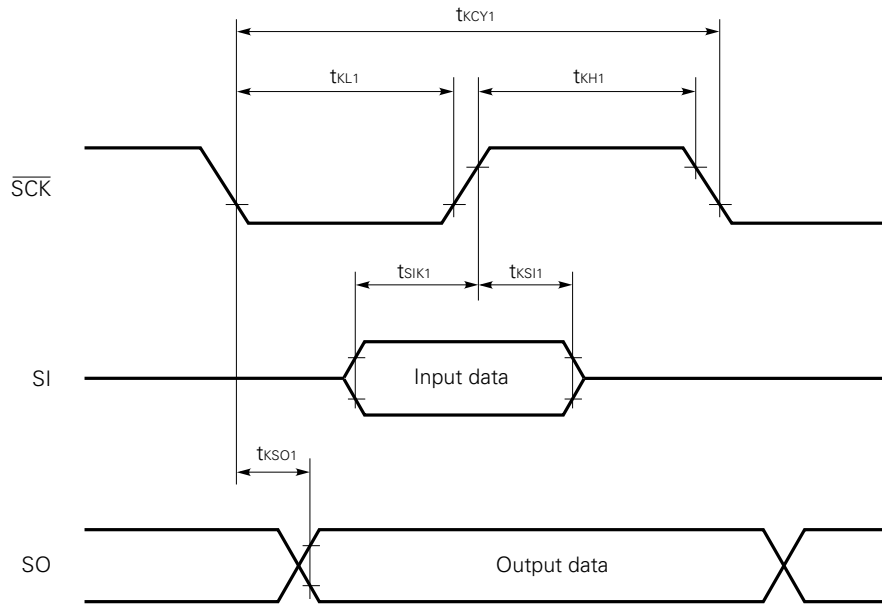

Two-wire serial I/O mode:

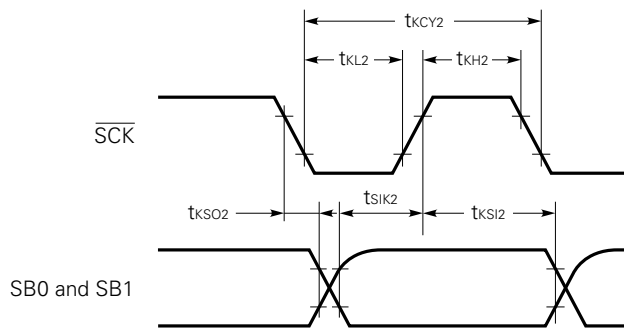

Serial Transfer Timing

Bus release signal transfer:

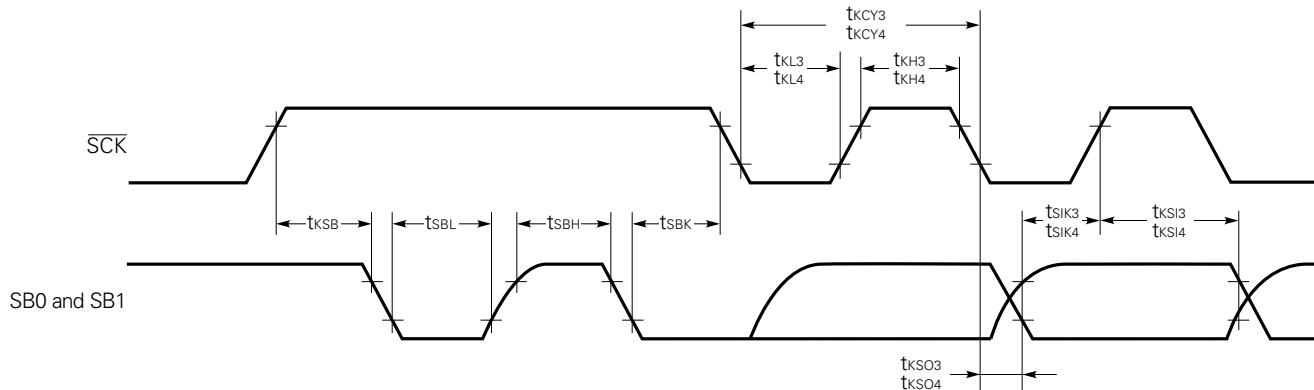

Command signal transfer:

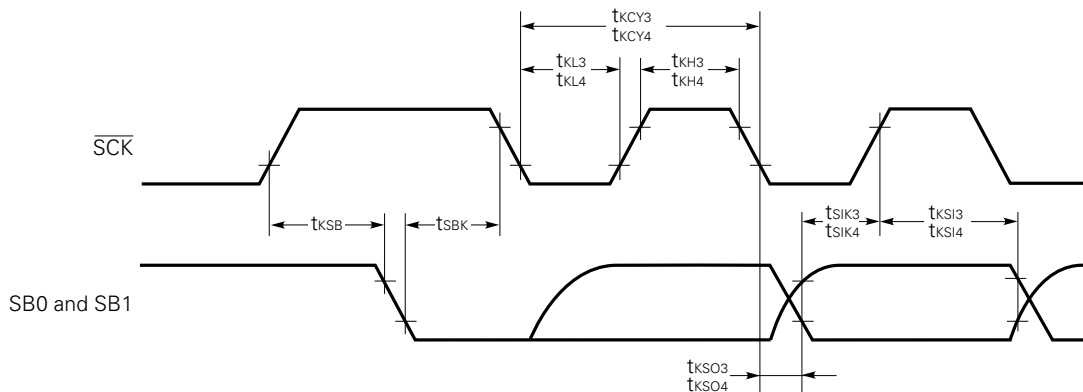

Interrupt Input Timing

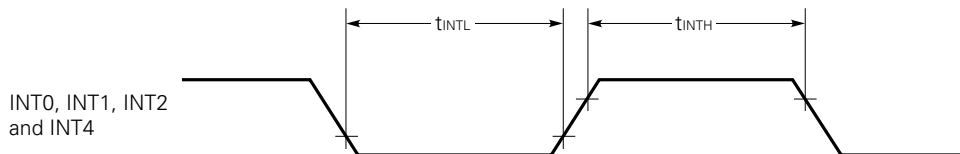

RESET Input Timing

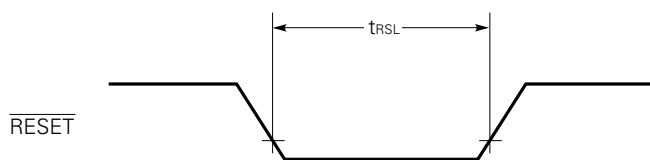

DATA HOLD CHARACTERISTICS BY LOW SUPPLY VOLTAGE IN DATA MEMORY STOP MODE

(T_a = -40 to +85 °C)

Parameter	Symbol	Min.	Typ.	Max.	Unit	Conditions
Data hold supply voltage	V _{DDDR}	2.0		6.0	V	
Data hold supply current ^{Note 1}	I _{DDDR}		0.1	10	μA	V _{DDDR} = 2.0 V
Release signal setting time	t _{SREL}	0			μs	
Oscillation stability wait time ^{Note 2}	t _{WAIT}		2 ¹⁷ /f _x		ms	Release by $\overline{\text{RESET}}$
			Note 3		ms	Release by interrupt request

- Notes**
1. Excluding the current which flows through the built-in pull-up or pull-down resistors
 2. CPU operation stop time for preventing unstable operation at the beginning of oscillation
 3. This value depends on the settings of the basic interval timer mode register (BTM) shown below.

BTM3	BTM2	BTM1	BTM0	Wait time	
				f _x = 6.0 MHz	f _x = 4.19 MHz
—	0	0	0	2 ²⁰ /f _x (approx. 175 ms)	2 ²⁰ /f _x (approx. 250 ms)
—	0	1	1	2 ¹⁷ /f _x (approx. 21.8 ms)	2 ¹⁷ /f _x (approx. 31.3 ms)
—	1	0	1	2 ¹⁵ /f _x (approx. 5.46 ms)	2 ¹⁵ /f _x (approx. 7.82 ms)
—	1	1	1	2 ¹³ /f _x (approx. 1.37 ms)	2 ¹³ /f _x (approx. 1.95 ms)

Data Hold Timing (STOP Mode Release by $\overline{\text{RESET}}$)

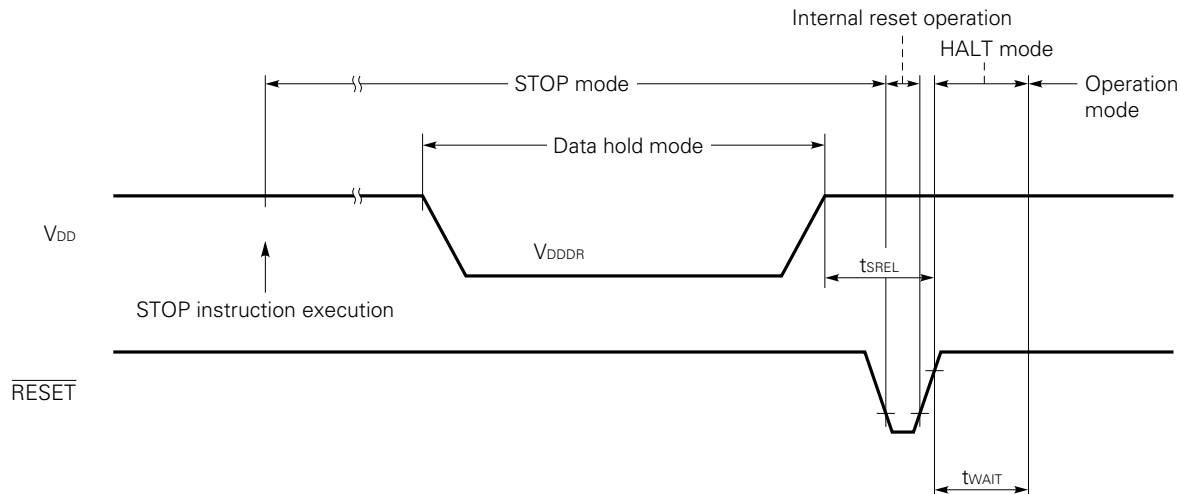

Data Hold Timing (Standby Release Signal: STOP Mode Release by Interrupt Signal)

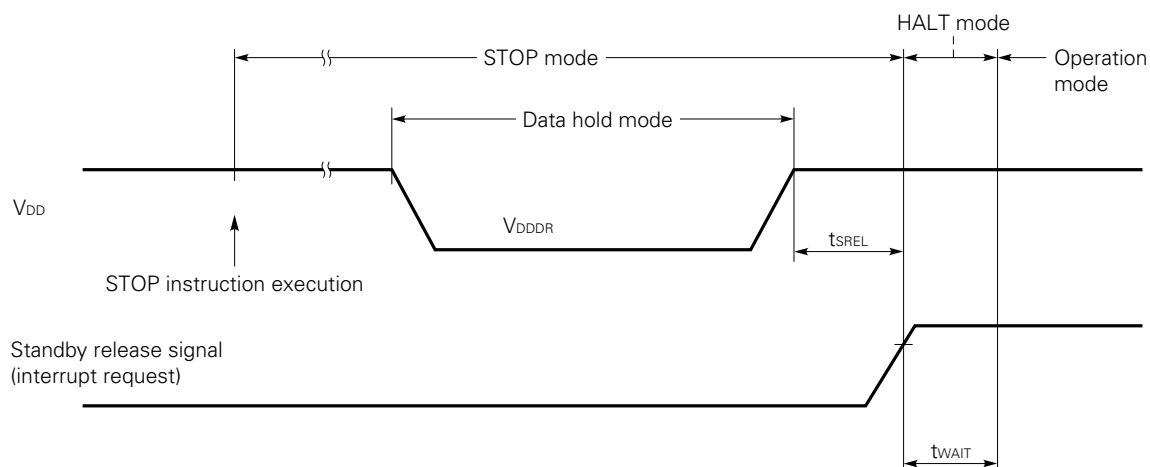

12. CHARACTERISTIC CURVES (FOR REFERENCE)



I_{DD} vs V_{DD} (Main System Clock: 6.0 MHz)

(T_a = 25 °C)

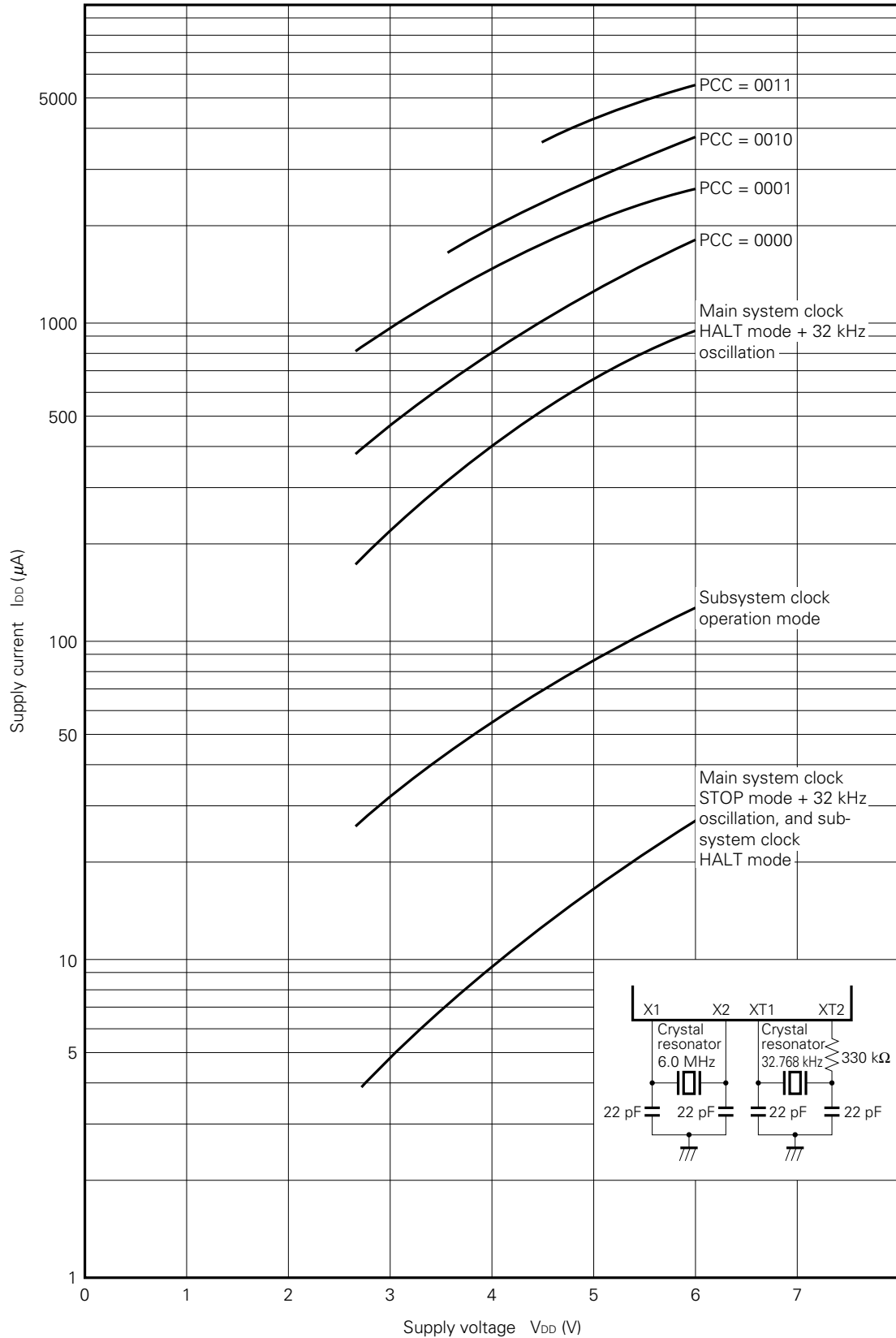

I_{DD} vs V_{DD} (Main System Clock: 4.19 MHz)

(T_a = 25 °C)

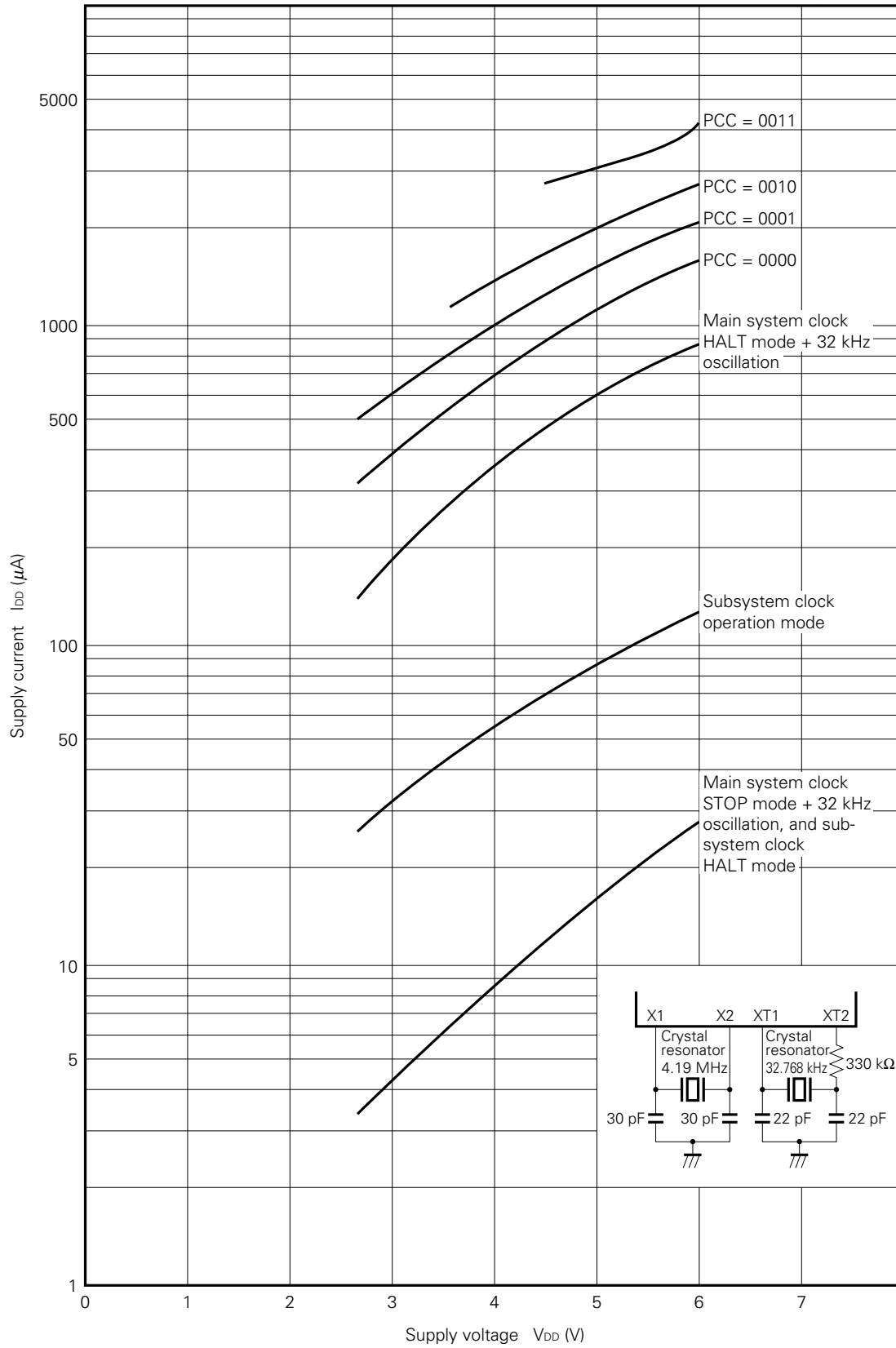

13. PACKAGE DIMENSIONS

94 PIN PLASTIC QFP (□ 20)

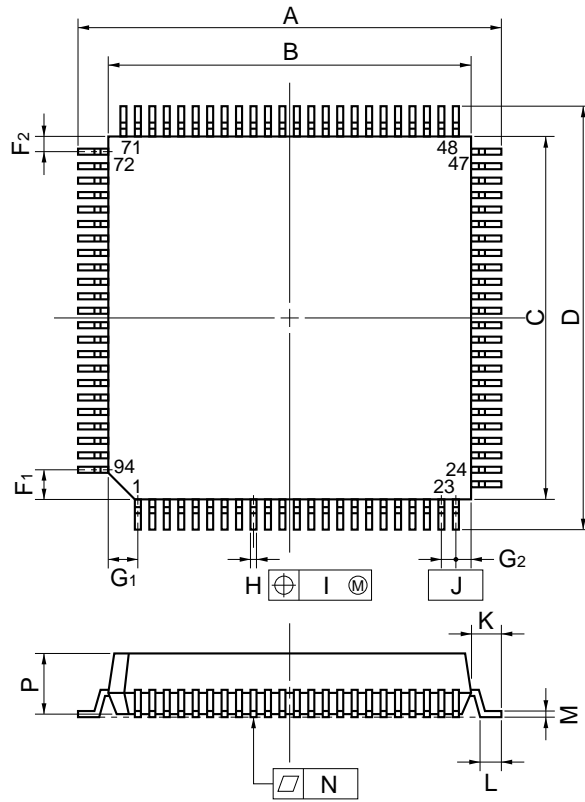

detail of lead end

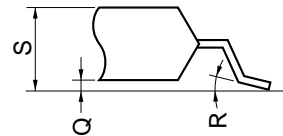

NOTE

Each lead centerline is located within 0.15 mm (0.006 inch) of its true position (T.P.) at maximum material condition.

ITEM	MILLIMETERS	INCHES
A	23.2±0.4	0.913 ^{+0.017} _{-0.016}
B	20.0±0.2	0.787 ^{+0.009} _{-0.008}
C	20.0±0.2	0.787 ^{+0.009} _{-0.008}
D	23.2±0.4	0.913 ^{+0.017} _{-0.016}
F ₁	1.6	0.063
F ₂	0.8	0.031
G ₁	1.6	0.063
G ₂	0.8	0.031
H	0.35±0.10	0.014 ^{+0.004} _{-0.005}
I	0.15	0.006
J	0.8 (T.P.)	0.031 (T.P.)
K	1.6±0.2	0.063±0.008
L	0.8±0.2	0.031 ^{+0.009} _{-0.008}
M	0.15 ^{+0.10} _{-0.05}	0.006 ^{+0.004} _{-0.003}
N	0.10	0.004
P	3.7	0.146
Q	0.1±0.1	0.004±0.004
R	5°±5°	5°±5°
S	4.0 MAX.	0.158 MAX.

★ 14. RECOMMENDED SOLDERING CONDITIONS

The following conditions must be met when soldering the μPD75238.

Please consult with our sales offices in case other soldering process is used, or in case soldering is done under different conditions.

Table 14-1 Recommended Soldering Conditions

Part number	Package	Symbol
μPD75238GJ-xxx-5BG	94-pin plastic QFP	WS60-107-1 IR30-107-1 VP15-107-1 Partial heating method

Table 14-2 Soldering Conditions

Symbol	Soldering process	Soldering conditions
WS60-107-1	Wave soldering	Temperature in the soldering vessel: 260 °C or below Soldering time: 10 seconds or less Number of soldering processes: 1 Exposure limit: 7 days ^{Note} (10 hours of pre-baking is required at 125 °C afterward.) Pre-heating temperature: 120 °C max. (package surface temperature)
IR30-107-1	Infrared ray reflow	Peak package's surface temperature: 230 °C Reflow time: 30 seconds or less (at 210 °C or higher) Number of reflow processes: 1 Exposure limit: 7 days ^{Note} (10 hours of pre-baking is required at 125 °C afterward.)
VP15-107-1	VPS	Peak package's surface temperature: 215 °C Reflow time: 40 seconds or less (at 200 °C or higher) Number of reflow processes: 1 Exposure limit: 7 days ^{Note} (10 hours of pre-baking is required at 125 °C afterward.)
Partial heating method	Partial heating method	Terminal temperature: 300 °C or below Flow time: 3 seconds or less (one side per device)

Note Exposure limit before soldering after dry-pack package is opened. Storage conditions: 25 °C and relative humidity at 65 % or less.

Caution Do not apply more than a single process at a time, except for "Partial heating method."

Remark For more details, refer to our document "SMT MANUAL" (IEI-1207).

APPENDIX A μPD75238 SERIES PRODUCT FUNCTION LIST

Item \ Product		μPD75217	μPD75236	μPD75237	μPD75238	μPD75P238
ROM		24448 × 8	16256 × 8	24448 × 8	32640 × 8	
RAM		768 × 4		1024 × 4		
Instruction cycle	When main system clock is selected	0.95 μs/1.91 μs/ 15.3 μs (at 4.19 MHz)	0.95 μs/1.91 μs/ 3.82 μs/15.3 μs (at 4.19 MHz)	0.67 μs/1.33 μs/2.67 μs/10.7 μs (at 6.0 MHz)		
	When sub-system clock is selected	122 μs (at 32.768 kHz)				
I/O lines (including FIP dual-function pins and excluding FIP-exclusive pins)	Total number of I/O lines	33	64			
	Number of input lines	8	16			
	Number of I/O lines	20: Eight lines for driving LED		24: 12 lines for driving LED		
	Number of output lines	5	24			
A/D converter		None		8 : 8-bit resolution		
FIP controller/driver	High-voltage output	26: 40 V (max.)		34: 40 V (max.)		
	Number of segments	9 to 16		9 to 24		
	Number of digits	9 to 16				
Timer		Four channels		Five channels		
Serial interface		One channel: 3-wire system		Two channels { SBI/3-wire system 3-wire system		
Number of interrupt sources		10		11		
Range of operating temperature		-40 to +85 °C				-40 to +70 °C
Operating power voltage		2.7 to 6.0 V				
Package		64-pin plastic shrink DIP 64-pin plastic QFP		94-pin plastic QFP		94-pin plastic QFP 94-pin ceramic LCC with a window

★ **APPENDIX B DEVELOPMENT TOOLS**

The following development tools are provided for developing a system which employs the μPD75238.

Language processor

RA75X relocatable assembler	Host machine	OS	Distribution media	Part number
	PC-9800 series	MS-DOS™ (Ver. 3.10 to Ver. 3.30C)	3.5-inch 2HD	μS5A13RA75X
			5-inch 2HD	μS5A10RA75X
	IBM PC series	PC DOS™ (Ver. 3.1)	5-inch 2HC	μS7B10RA75X

PROM programming tools

Hardware	PG-1500	A PROM programmer with which programs can be written into PROMs through keyboards or by remote control, when connected with the accessory board and optional programmer adapter. Products programmable with the PG-1500 are commonly-used PROMs (256K-bit to 1M-bit) and single chip microcomputers containing a PROM.			
	PA-75P238GJ	A PROM programmer adapter for the μPD75P238. This adapter is connected to the PG-1500.			
Software	PG-1500 controller	This program enables the host machine to control the PG-1500 through the serial and parallel interfaces.			
		Host machine	OS	Distribution media	Part number
		PC-9800 series	MS-DOS (Ver. 3.10 to Ver. 3.30C)	3.5-inch 2HD	μS5A13PG1500
				5-inch 2HD	μS5A10PG1500
IBM PC series	PC DOS (Ver. 3.1)	5-inch 2HC	μS7B10PG1500		

Debugging tools

Hardware	IE-75000-R ^{Note}	The IE-75000-R is an in-circuit emulator available for the 75X series. This emulator is used together with the emulation probe to develop application systems of the μPD75238. For efficient debugging, the emulator is connected to the host machine and PROM programmer.			
	IE-75000-R-EM	The IE-75000-R-EM is an emulation board for the IE-75000-R and IE-75001-R. The IE-75000-R contains the emulation board. The emulation board is used together with the IE-75000-R or IE-75001-R to evaluate the μPD75238.			
	IE-75001-R	The IE-75001-R is an in-circuit emulator available for the 75X series. This emulator is used together with the IE-75000-R-EM emulation board (option) and emulation probe to develop application systems of the μPD75238. For efficient debugging, the emulator is connected to the host machine and PROM programmer.			
	EP-75238GJ-R	The EP-75238GJ-R is an emulation probe for the μPD75238 (94-pin plastic QFP). The emulation probe is connected to the IE-75000-R or IE-75001-R when it is used. A 94-pin conversion socket, the EV-9200G-94, attached to the probe facilitates the connection of the probe with the user system.			
	EV-9200G-94				
Software	IE control program	This program enables the host machine to control the IE-75000-R or IE-75001-R through the RS-232-C interface.			
		Host machine	OS	Distribution media	Part number
		PC-9800 series	MS-DOS (Ver. 3.10 to Ver. 3.30C)	3.5-inch 2HD	μS5A13IE75X
				5-inch 2HD	μS5A10IE75X
		IBM PC series	PC DOS (Ver. 3.1)	5-inch 2HC	μS7B10IE75X

Note Maintenance service only

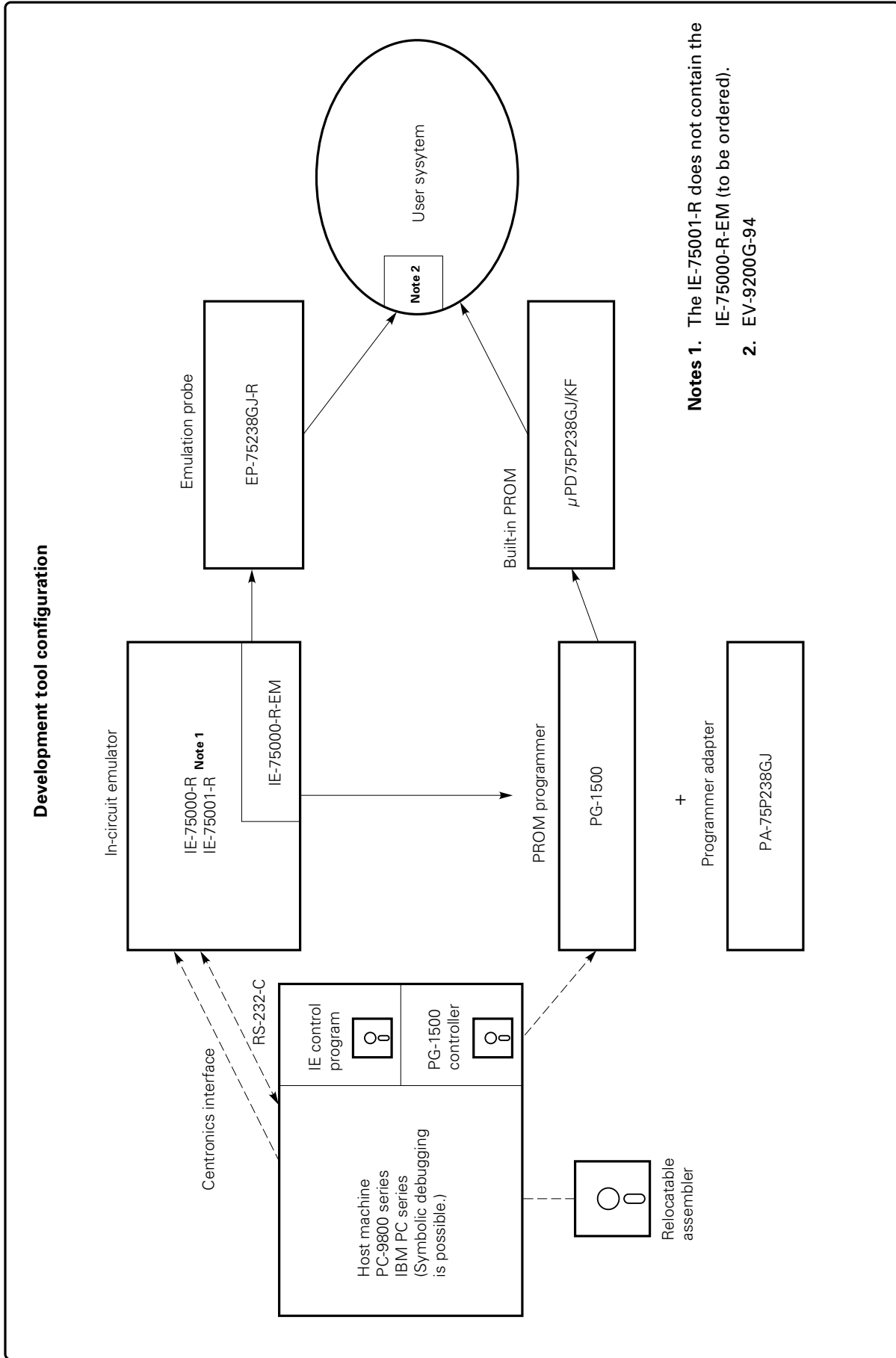

[MEMO]

[MEMO]

No part of this document may be copied or reproduced in any form or by any means without the prior written consent of NEC Corporation. NEC Corporation assumes no responsibility for any errors which may appear in this document.

NEC Corporation does not assume any liability for infringement of patents, copyrights or other intellectual property rights of third parties by or arising from use of a device described herein or any other liability arising from use of such device. No license, either express, implied or otherwise, is granted under any patents, copyrights or other intellectual property rights of NEC Corporation or others.

The devices listed in this document are not suitable for use in aerospace equipment, submarine cables, nuclear reactor control systems and life support systems. If customers intend to use NEC devices for above applications or they intend to use "Standard" quality grade NEC devices for applications not intended by NEC, please contact our sales people in advance.

Application examples recommended by NEC Corporation

Standard: Computer, Office equipment, Communication equipment, Test and Measurement equipment, Machine tools, Industrial robots, Audio and Visual equipment, Other consumer products, etc.

Special: Automotive and Transportation equipment, Traffic control systems, Antidisaster systems, Anticrime systems, etc.

M4 92.6

FIP® is a registered trademark of NEC Corporation.

MS-DOS™ is a trademark of Microsoft Corporation.

PC DOS™ is a trademark of IBM Corporation.