

# 3967

Data Sheet  
26184.24C

## MICROSTEPPING DRIVER WITH TRANSLATOR

The A3967SLB is a complete microstepping motor driver with built-in translator. It is designed to operate bipolar stepper motors in full-, half-, quarter-, and eighth-step modes, with output drive capability of 30 V and  $\pm 750$  mA. The A3967SLB includes a fixed off-time current regulator that has the ability to operate in slow, fast, or mixed current-decay modes. This current-decay control scheme results in reduced audible motor noise, increased step accuracy, and reduced power dissipation.

The translator is the key to the easy implementation of the A3967SLB. By simply inputting one pulse on the STEP input the motor will take one step (full, half, quarter, or eighth depending on two logic inputs). There are no phase-sequence tables, high-frequency control lines, or complex interfaces to program. The A3967SLB interface is an ideal fit for applications where a complex  $\mu P$  is unavailable or over-burdened.

Internal circuit protection includes thermal shutdown with hysteresis, under-voltage lockout (UVLO) and crossover-current protection. Special power-up sequencing is not required.

The A3967SLB is supplied in a 24-lead SOIC with copper batwing tabs. The tabs are at ground potential and need no insulation. A lead-free (100% matte tin leadframe) version is also available.

### FEATURES

- $\pm 750$  mA, 30 V Output Rating
- Satlington™ Sink Drivers
- Automatic Current-Decay Mode Detection/Selection
- 3.0 V to 5.5 V Logic Supply Voltage Range
- Mixed, Fast, and Slow Current-Decay Modes
- Internal UVLO and Thermal Shutdown Circuitry
- Crossover-Current Protection

Always order by complete part number:

Part Number	Package
A3967SLB	24-lead batwing SOIC
A3967SLB-T	24-lead batwing SOIC; Lead-free

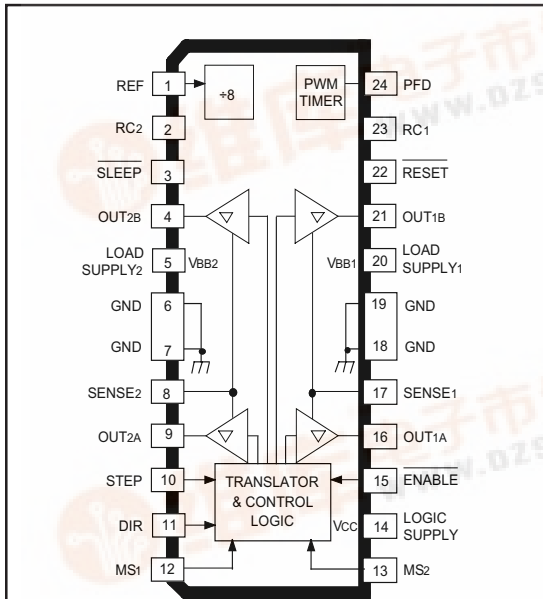

Dwg. PP-075-2

### ABSOLUTE MAXIMUM RATINGS at $T_A = +25^\circ C$

Load Supply Voltage, $V_{BB}$ .....	<b>30 V</b>
Output Current, $I_{OUT}$	
Continuous .....	<b><math>\pm 750</math> mA*</b>
Peak .....	<b><math>\pm 850</math> mA</b>
Logic Supply Voltage, $V_{CC}$ .....	<b>7.0 V</b>
Logic Input Voltage Range, $V_{IN}$	
( $t_w > 30$ ns) .....	<b>-0.3 V to +7.0 V</b>
( $t_w < 30$ ns) .....	<b>-1 V to +7.0 V</b>
Sense Voltage, $V_{SENSE}$ .....	<b>0.68 V</b>
Reference Voltage, $V_{REF}$ .....	<b><math>V_{CC}</math></b>
Package Power Dissipation, $P_D$ .....	<b>See page 8</b>
Operating Temperature Range, $T_A$ .....	<b><math>-20^\circ C</math> to <math>+85^\circ C</math></b>
Junction Temperature, $T_J$ .....	<b><math>+150^\circ C</math></b>
Storage Temperature Range, $T_S$ .....	<b><math>-55^\circ C</math> to <math>+150^\circ C</math></b>

\* Output current rating may be limited by duty cycle, ambient temperature, and heat sinking. Under any set of conditions, do not exceed the specified current rating or a junction temperature of  $150^\circ C$ .



# 3967 MICROSTEPPING DRIVER WITH TRANSLATOR

## FUNCTIONAL BLOCK DIAGRAM

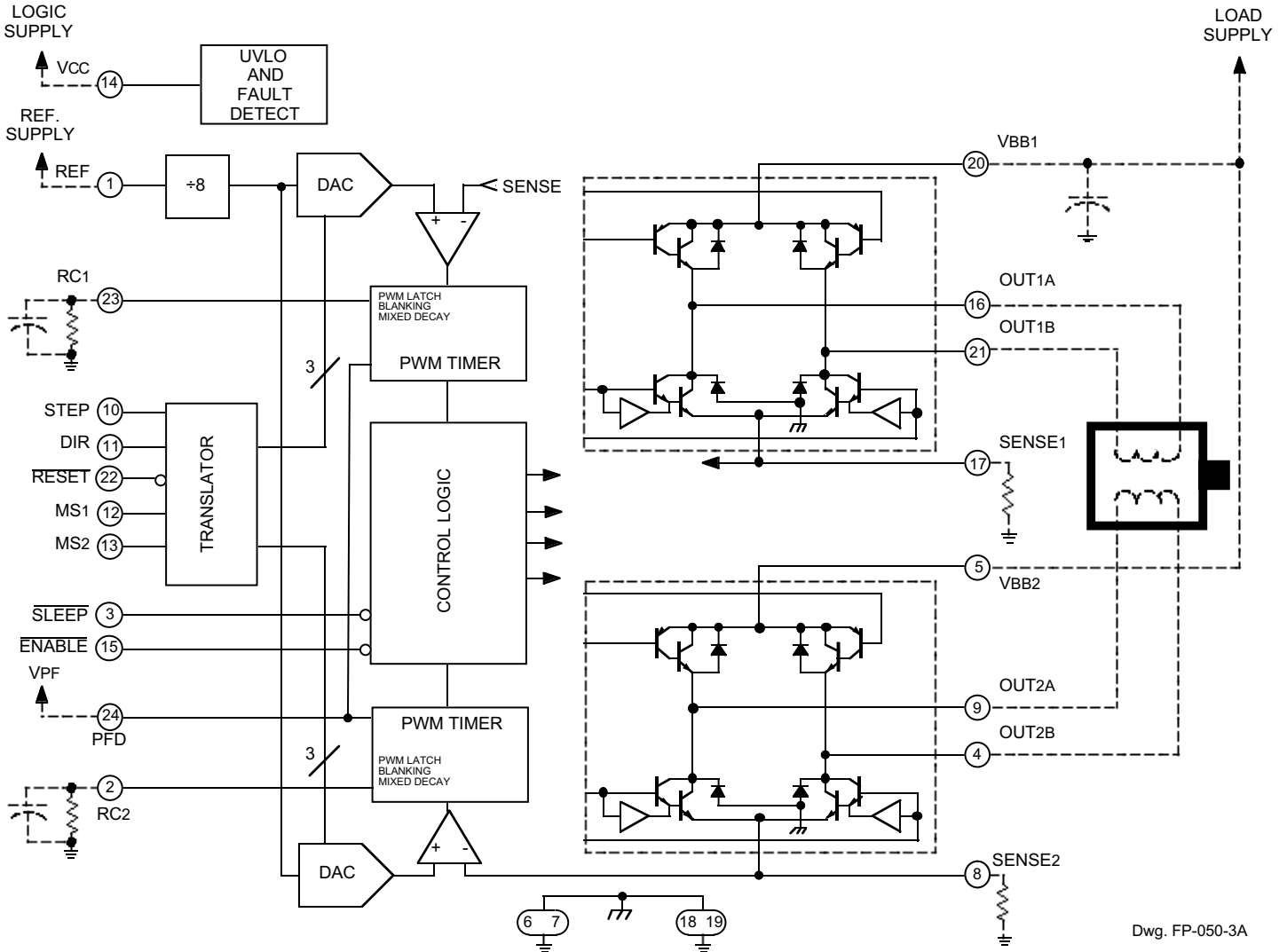

Dwg. FP-050-3A

**Table 1. Microstep Resolution Truth Table**

MS <sub>1</sub>	MS <sub>2</sub>	Resolution
L	L	Full step (2 phase)
H	L	Half step
L	H	Quarter step
H	H	Eighth step

**3967**  
**MICROSTEPPING DRIVER**  
**WITH TRANSLATOR**

**ELECTRICAL CHARACTERISTICS** at  $T_A = +25^\circ\text{C}$ ,  $V_{BB} = 30\text{ V}$ ,  $V_{CC} = 3.0\text{ V}$  to  $5.5\text{ V}$  (unless otherwise noted)

Characteristic	Symbol	Test Conditions	Limits			
			Min.	Typ.	Max.	Units
<b>Output Drivers</b>						
Load Supply Voltage Range	$V_{BB}$	Operating	4.75	–	30	V
		During sleep mode	0	–	30	V
Output Leakage Current	$I_{CEX}$	$V_{OUT} = V_{BB}$	–	<1.0	20	$\mu\text{A}$
		$V_{OUT} = 0\text{ V}$	–	<-1.0	-20	$\mu\text{A}$
Output Saturation Voltage	$V_{CE(sat)}$	Source driver, $I_{OUT} = -750\text{ mA}$	–	1.9	2.1	V
		Source driver, $I_{OUT} = -400\text{ mA}$	–	1.7	2.0	V
		Sink driver, $I_{OUT} = 750\text{ mA}$	–	0.65	1.3	V
		Sink driver, $I_{OUT} = 400\text{ mA}$	–	0.21	0.5	V
Clamp Diode Forward Voltage	$V_F$	$I_F = 750\text{ mA}$	–	1.4	1.6	V
		$I_F = 400\text{ mA}$	–	1.1	1.4	V
Motor Supply Current	$I_{BB}$	Outputs enabled	–	–	5.0	mA
		RESET high	–	–	200	$\mu\text{A}$
		Sleep mode	–	–	20	$\mu\text{A}$
<b>Control Logic</b>						
Logic Supply Voltage Range	$V_{CC}$	Operating	3.0	5.0	5.5	V
Logic Input Voltage	$V_{IN(1)}$		$0.7V_{CC}$	–	–	V
	$V_{IN(0)}$		–	–	$0.3V_{CC}$	V
Logic Input Current	$I_{IN(1)}$	$V_{IN} = 0.7V_{CC}$	-20	<1.0	20	$\mu\text{A}$
	$I_{IN(0)}$	$V_{IN} = 0.3V_{CC}$	-20	<1.0	20	$\mu\text{A}$
Maximum STEP Frequency	$f_{STEP}$		500*	–	–	kHz
Blank Time	$t_{BLANK}$	$R_t = 56\text{ k}\Omega$ , $C_t = 680\text{ pF}$	700	950	1200	ns
Fixed Off Time	$t_{off}$	$R_t = 56\text{ k}\Omega$ , $C_t = 680\text{ pF}$	30	38	46	$\mu\text{s}$

continued next page ...

# 3967 MICROSTEPPING DRIVER WITH TRANSLATOR

**ELECTRICAL CHARACTERISTICS** at  $T_A = +25^\circ\text{C}$ ,  $V_{BB} = 30\text{ V}$ ,  $V_{CC} = 3.0\text{ V to }5.5\text{ V}$  (unless otherwise noted)

Characteristic	Symbol	Test Conditions	Limits			
			Min.	Typ.	Max.	Units
<b>Control Logic (cont'd)</b>						
Mixed Decay Trip Point	PFDH		–	$0.6V_{CC}$	–	V
	PFDL		–	$0.21V_{CC}$	–	V
Ref. Input Voltage Range	$V_{REF}$	Operating	1.0	–	$V_{CC}$	V
Reference Input Impedance	$Z_{REF}$		120	160	200	k $\Omega$
Gain ( $G_m$ ) Error (note 3)	$E_G$	$V_{REF} = 2\text{ V}$ , Phase Current = 38.37% †	–	–	$\pm 10$	%
		$V_{REF} = 2\text{ V}$ , Phase Current = 70.71% †	–	–	$\pm 5.0$	%
		$V_{REF} = 2\text{ V}$ , Phase Current = 100.00% †	–	–	$\pm 5.0$	%
Thermal Shutdown Temp.	$T_J$		–	165	–	$^\circ\text{C}$
Thermal Shutdown Hysteresis	$\Delta T_J$		–	15	–	$^\circ\text{C}$
UVLO Enable Threshold	$V_{UVLO}$	Increasing $V_{CC}$	2.45	2.7	2.95	V
UVLO Hysteresis	$\Delta V_{UVLO}$		0.05	0.10	–	V
Logic Supply Current	$I_{CC}$	Outputs enabled	–	50	65	mA
		Outputs off	–	–	9.0	mA
		Sleep mode	–	–	20	$\mu\text{A}$

\* Operation at a step frequency greater than the specified minimum value is possible but not warranted.

† 8 microstep/step operation.

NOTES: 1. Typical Data is for design information only.

2. Negative current is defined as coming out of (sourcing) the specified device terminal.

3.  $E_G = ([V_{REF}/8] - V_{SENSE})/(V_{REF}/8)$

# 3967 MICROSTEPPING DRIVER WITH TRANSLATOR

## Functional Description

**Device Operation.** The A3967 is a complete microstepping motor driver with built in translator for easy operation with minimal control lines. It is designed to operate bipolar stepper motors in full-, half-, quarter- and eighth-step modes. The current in each of the two output H-bridges is regulated with fixed off time pulse-width modulated (PWM) control circuitry. The H-bridge current at each step is set by the value of an external current sense resistor ( $R_S$ ), a reference voltage ( $V_{REF}$ ), and the DAC's output voltage controlled by the output of the translator.

At power up, or reset, the translator sets the DACs and phase current polarity to initial home state (see figures for home-state conditions), and sets the current regulator for both phases to mixed-decay mode. When a step command signal occurs on the STEP input the translator automatically sequences the DACs to the next level (see table 2 for the current level sequence and current polarity). The microstep resolution is set by inputs  $MS_1$  and  $MS_2$  as shown in table 1. If the new DAC output level is lower than the previous level the decay mode for that H-bridge will be set by the PFD input (fast, slow or mixed decay). If the new DAC level is higher or equal to the previous level then the decay mode for that H-bridge will be slow decay. This automatic current-decay selection will improve microstepping performance by reducing the distortion of the current waveform due to the motor BEMF.

**Reset Input (RESET).** The RESET input (active low) sets the translator to a predefined home state (see figures for home state conditions) and turns off all of the outputs. STEP inputs are ignored until the RESET input goes high.

**Step Input (STEP).** A low-to-high transition on the STEP input sequences the translator and advances the motor one increment. The translator controls the input to the DACs and the direction of current flow in each winding. The size of the increment is determined by the state of inputs  $MS_1$  and  $MS_2$  (see table 1).

**Microstep Select ( $MS_1$  and  $MS_2$ ).** Input terminals  $MS_1$  and  $MS_2$  select the microstepping format per table 1. Changes to these inputs do not take effect until the STEP command (see figure).

**Direction Input (DIR).** The state of the DIRECTION input will determine the direction of rotation of the motor.

**Internal PWM Current Control.** Each H-bridge is controlled by a fixed off time PWM current-control circuit that limits the load current to a desired value ( $I_{TRIP}$ ). Initially, a diagonal pair of source and sink outputs are enabled and current flows through the motor winding and  $R_S$ . When the voltage across the current-sense resistor equals the DAC output voltage, the current-sense comparator resets the PWM latch, which turns off the source driver (slow-decay mode) or the sink and source drivers (fast- or mixed-decay modes).

The maximum value of current limiting is set by the selection of  $R_S$  and the voltage at the  $V_{REF}$  input with a transconductance function approximated by:

$$I_{TRIPmax} = V_{REF}/8R_S$$

The DAC output reduces the  $V_{REF}$  output to the current-sense comparator in precise steps (see table 2 for %  $I_{TRIPmax}$  at each step).

$$I_{TRIP} = (\% I_{TRIPmax}/100) \times I_{TRIPmax}$$

**Fixed Off-Time.** The internal PWM current-control circuitry uses a one shot to control the time the driver(s) remain(s) off. The one shot off-time,  $t_{off}$ , is determined by the selection of an external resistor ( $R_T$ ) and capacitor ( $C_T$ ) connected from the RC timing terminal to ground. The off time, over a range of values of  $C_T = 470$  pF to 1500 pF and  $R_T = 12$  k $\Omega$  to 100 k $\Omega$  is approximated by:

$$t_{off} = R_T C_T$$

# 3967

## MICROSTEPPING DRIVER WITH TRANSLATOR

### Functional Description (cont'd)

**RC Blanking.** In addition to the fixed off time of the PWM control circuit, the  $C_T$  component sets the comparator blanking time. This function blanks the output of the current-sense comparator when the outputs are switched by the internal current-control circuitry. The comparator output is blanked to prevent false over-current detection due to reverse recovery currents of the clamp diodes, and/or switching transients related to the capacitance of the load. The blank time  $t_{BLANK}$  can be approximated by:

$$t_{BLANK} = 1400C_T$$

**Enable Input (ENABLE).** This active-low input enables all of the outputs. When logic high the outputs are disabled. Inputs to the translator (STEP, DIRECTION,  $MS_1$ ,  $MS_2$ ) are all active independent of the ENABLE input state.

**Shutdown.** In the event of a fault (excessive junction temperature) the outputs of the device are disabled until the fault condition is removed. At power up, and in the event of low  $V_{CC}$ , the under-voltage lockout (UVLO) circuit disables the drivers and resets the translator to the home state.

**Sleep Mode (SLEEP).** An active-low control input used to minimize power consumption when not in use. This disables much of the internal circuitry including the outputs. A logic high allows normal operation and startup of the device in the home position.

Typical output saturation  
voltages showing Satlington™  
sink-driver operation.

**Percent Fast Decay Input (PFD).** When a STEP input signal commands a lower output current from the previous step, it switches the output current decay to either slow-, fast-, or mixed-decay depending on the voltage level at the PFD input. If the voltage at the PFD input is greater than  $0.6V_{CC}$  then slow-decay mode is selected. If the voltage on the PFD input is less than  $0.21V_{CC}$  then fast-decay mode is selected. Mixed decay is between these two levels.

**Mixed Decay Operation.** If the voltage on the PFD input is between  $0.6V_{CC}$  and  $0.21V_{CC}$ , the bridge will operate in mixed-decay mode depending on the step sequence (see figures). As the trip point is reached, the device will go into fast-decay mode until the voltage on the RC terminal decays to the voltage applied to the PFD terminal. The time that the device operates in fast decay is approximated by:

$$t_{FD} = R_T C_T \ln(0.6V_{CC}/V_{PFD})$$

After this fast decay portion,  $t_{FD}$ , the device will switch to slow-decay mode for the remainder of the fixed off-time period.

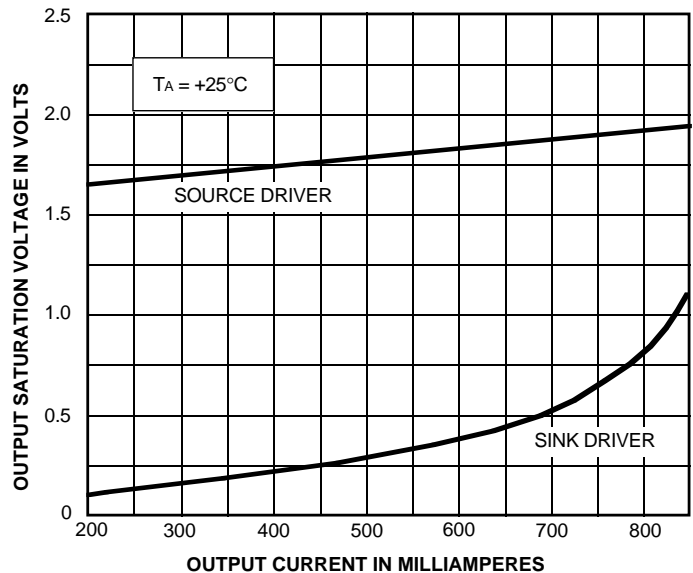

Dwg. GP-064-4

**3967**  
**MICROSTEPPING DRIVER**  
**WITH TRANSLATOR**

**Timing Requirements**  
( $T_A = +25^\circ\text{C}$ ,  $V_{CC} = 5\text{ V}$ , Logic Levels are  $V_{CC}$  and Ground)

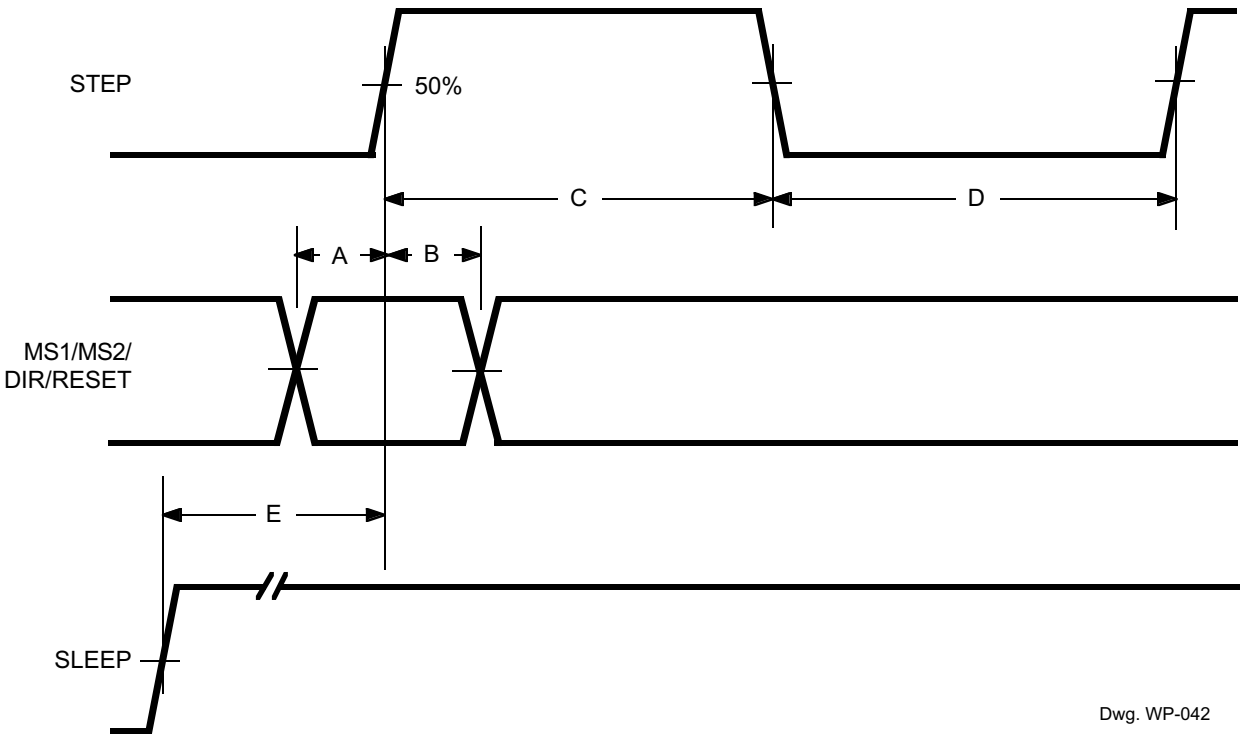

Dwg. WP-042

- A. Minimum Command Active Time  
Before Step Pulse (Data Set-Up Time) ..... 200 ns
- B. Minimum Command Active Time  
After Step Pulse (Data Hold Time)..... 200 ns
- C. Minimum STEP Pulse Width ..... 1.0  $\mu\text{s}$
- D. Minimum STEP Low Time ..... 1.0  $\mu\text{s}$
- E. Maximum Wake-Up Time ..... 1.0 ms

# 3967 MICROSTEPPING DRIVER WITH TRANSLATOR

## Applications Information

**Layout.** The printed wiring board should use a heavy ground plane.

For optimum electrical and thermal performance, the driver should be soldered directly onto the board.

The load supply terminal,  $V_{BB}$ , should be decoupled with an electrolytic capacitor (>47  $\mu$ F is recommended) placed as close to the device as possible.

To avoid problems due to capacitive coupling of the high dv/dt switching transients, route the bridge-output traces away from the sensitive logic-input traces. Always drive the logic inputs with a low source impedance to increase noise immunity.

**Grounding.** A star ground system located close to the driver is recommended.

The 24-lead SOIC has the analog ground and the power ground internally bonded to the power tabs of the package (leads 6, 7, 18, and 19).

**Current Sensing.** To minimize inaccuracies caused by ground-trace IR drops in sensing the output current level, the current-sense resistor ( $R_S$ ) should have an independent ground return to the star ground of the device. This path should be as short as possible. For low-value sense resistors the IR drops in the printed wiring board sense resistor's traces can be significant and should be taken into account. The use of sockets should be avoided as they can introduce variation in  $R_S$  due to their contact resistance.

Allegro MicroSystems recommends a value of  $R_S$  given by

$$R_S = 0.5/I_{TRIPmax}$$

**Thermal protection.** Circuitry turns off all drivers when the junction temperature reaches 165°C, typically. It is intended only to protect the device from failures due to excessive junction temperatures and should not imply that output short circuits are permitted. Thermal shut-down has a hysteresis of approximately 15°C.

\* $R_{\theta JA} = 35^\circ\text{C/W}$  on JEDEC standard  
"High-K" four-layer board per JESD 51-7.

† $R_{\theta JA} = 50^\circ\text{C/W}$  on typical two-sided PCB with  
1.3 square inches copper ground on each side.

See also, Application Note 29501.5,  
*Improving Batwing Power Dissipation.*

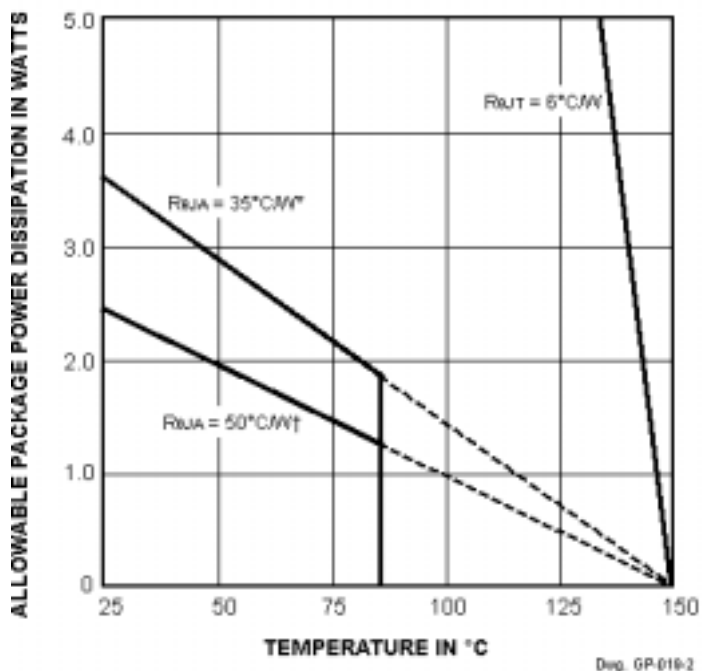



**3967**  
**MICROSTEPPING DRIVER**  
**WITH TRANSLATOR**

**Table 2. Step Sequencing**  
Home State = 45° Step Angle, DIR = H

Full Step	Half Step	¼ Step	⅛ Step	Phase 1 Current (%I <sub>trip,max</sub> ) (%)	Phase 2 Current (%I <sub>trip,max</sub> ) (%)	Step Angle (°)
	1	1	1	100.00	0.00	0.0
			2	98.08	19.51	11.3
		2	3	92.39	38.27	22.5
			4	83.15	55.56	33.8
1	2	3	5	70.71	70.71	45.0
			6	55.56	83.15	56.3
		4	7	38.27	92.39	67.5
			8	19.51	98.08	78.8
	3	5	9	0.00	100.00	90.0
			10	-19.51	98.08	101.3
		6	11	-38.27	92.39	112.5
			12	-55.56	83.15	123.8
2	4	7	13	-70.71	70.71	135.0
			14	-83.15	55.56	146.3
		8	15	-92.39	38.27	157.5
			16	-98.08	19.51	168.8
	5	9	17	-100.00	0.00	180.0
			18	-98.08	-19.51	191.3
		10	19	-92.39	-38.27	202.5
			20	-83.15	-55.56	213.8
3	6	11	21	-70.71	-70.71	225.0
			22	-55.56	-83.15	236.3
		12	23	-38.27	-92.39	247.5
			24	-19.51	-98.08	258.8
	7	13	25	0.00	-100.00	270.0
			26	19.51	-98.08	281.3
		14	27	38.27	-92.39	292.5
			28	55.56	-83.15	303.8
4	8	15	29	70.71	-70.71	315.0
			30	83.15	-55.56	326.3
		16	31	92.39	-38.27	337.5
			32	98.08	-19.51	348.8

**3967**  
**MICROSTEPPING DRIVER**  
**WITH TRANSLATOR**

**Full Step Operation**  
 $MS_1 = MS_2 = L, DIR = H$

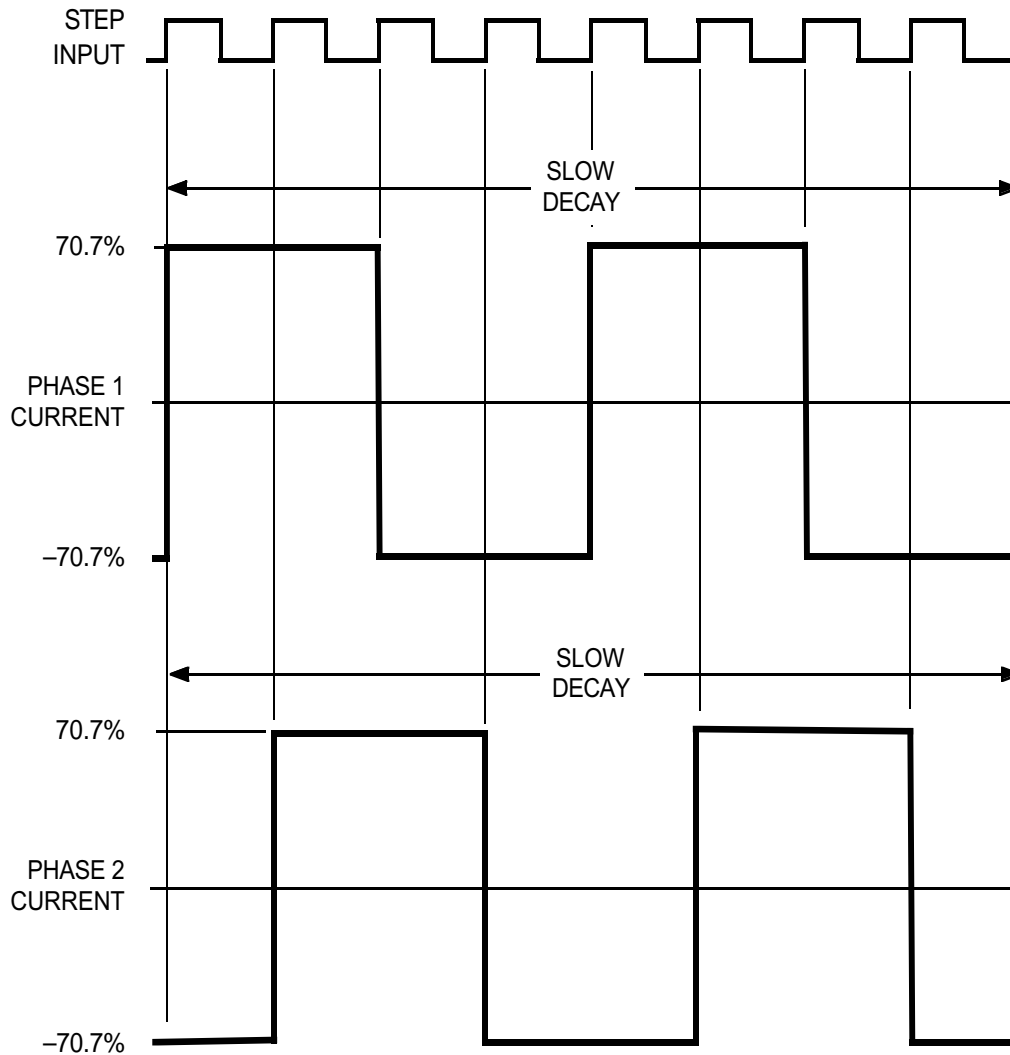

Dwg. WK-004-19

The vector addition of the output currents at any step is 100%.

# 3967 MICROSTEPPING DRIVER WITH TRANSLATOR

## Half Step Operation MS<sub>1</sub> = H, MS<sub>2</sub> = L, DIR = H

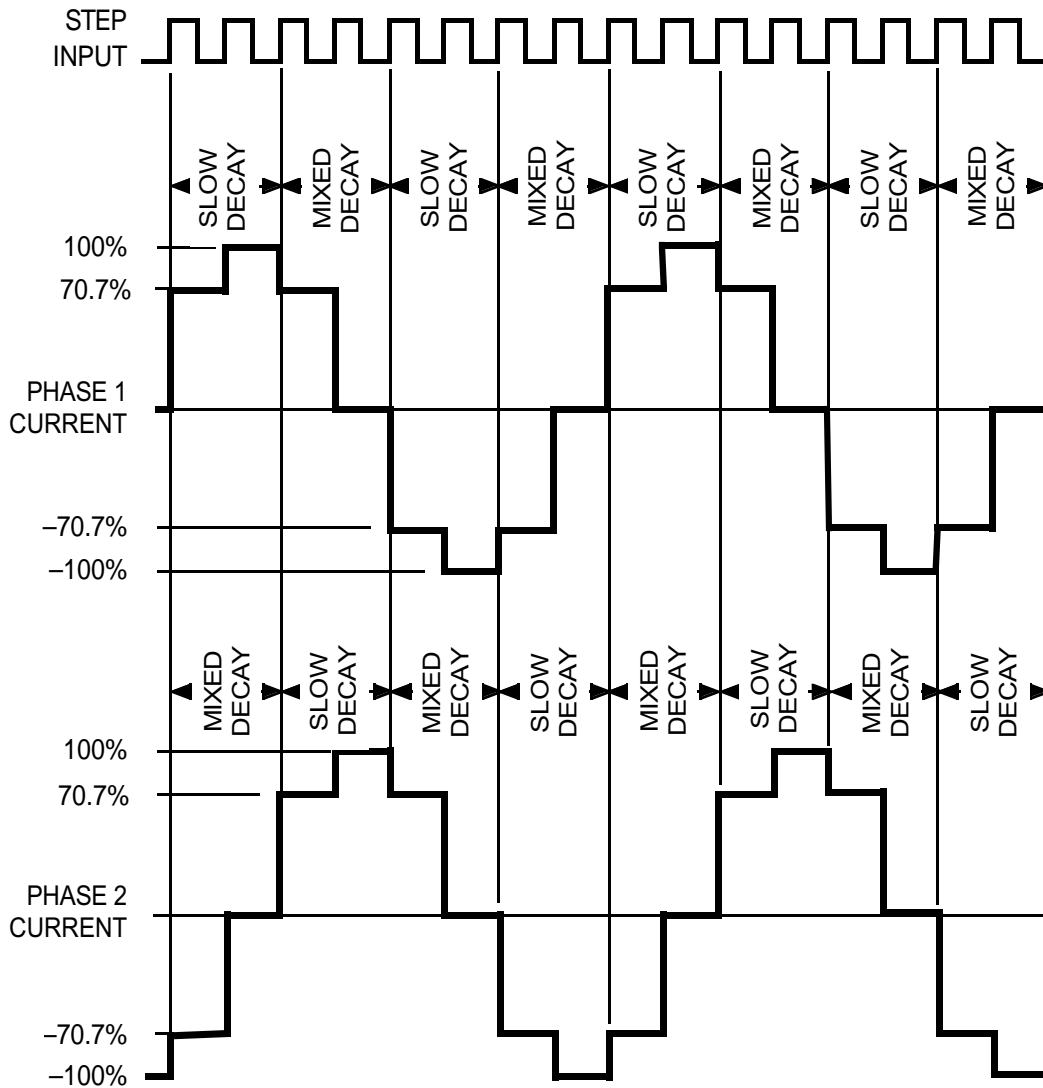

Dwg. WK-004-18

The mixed-decay mode is controlled by the percent fast decay voltage ( $V_{\text{PFD}}$ ). If the voltage at the PFD input is greater than  $0.6V_{\text{CC}}$  then slow-decay mode is selected. If the voltage on the PFD input is less than  $0.21V_{\text{CC}}$  then fast-decay mode is selected. Mixed decay is between these two levels.

# 3967 MICROSTEPPING DRIVER WITH TRANSLATOR

## Quarter Step Operation MS<sub>1</sub> = L, MS<sub>2</sub> = H, DIR = H

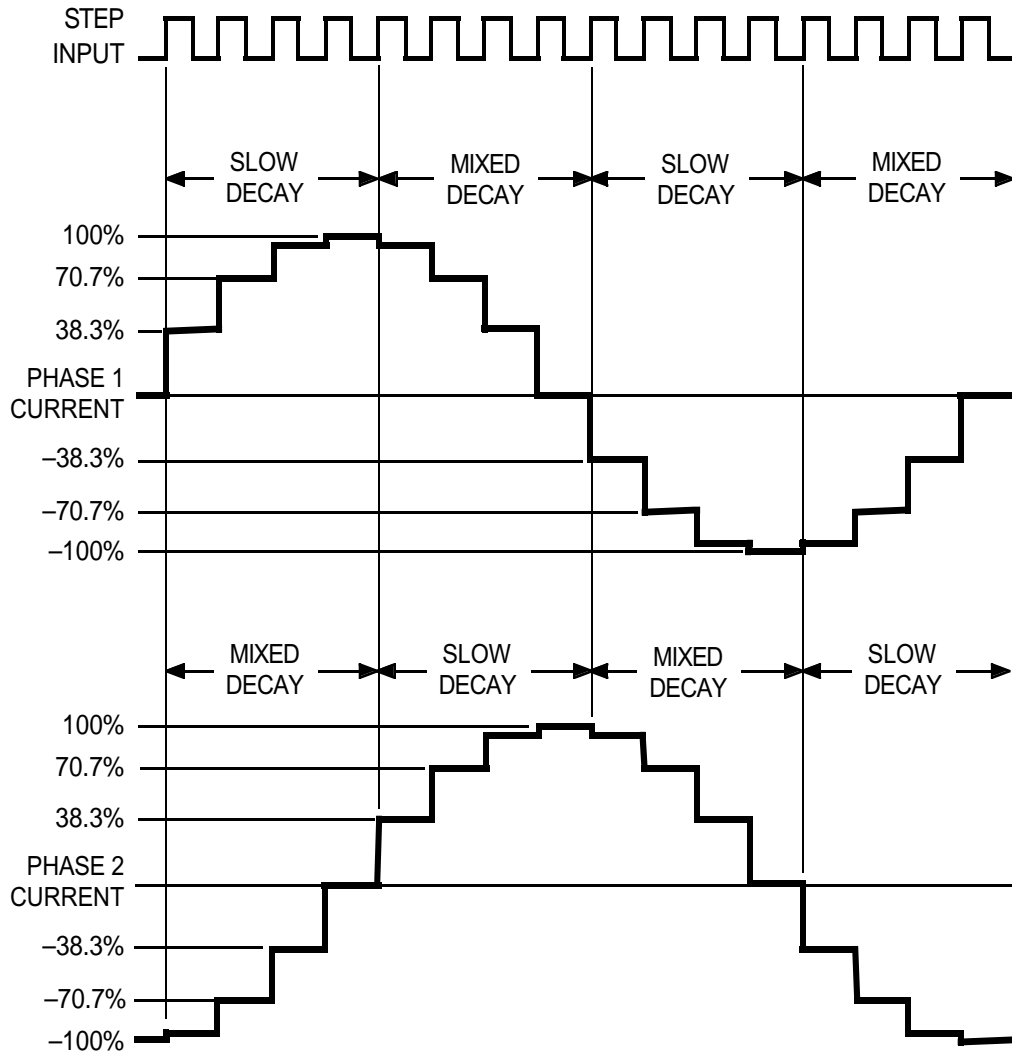

Dwg. WK-004-17

The mixed-decay mode is controlled by the percent fast decay voltage ( $V_{PFD}$ ). If the voltage at the PFD input is greater than  $0.6V_{CC}$  then slow-decay mode is selected. If the voltage on the PFD input is less than  $0.21V_{CC}$  then fast-decay mode is selected. Mixed decay is between these two levels.

**3967**  
**MICROSTEPPING DRIVER**  
**WITH TRANSLATOR**

**8 Microstep/Step Operation**  
 $MS_1 = MS_2 = H, DIR = H$

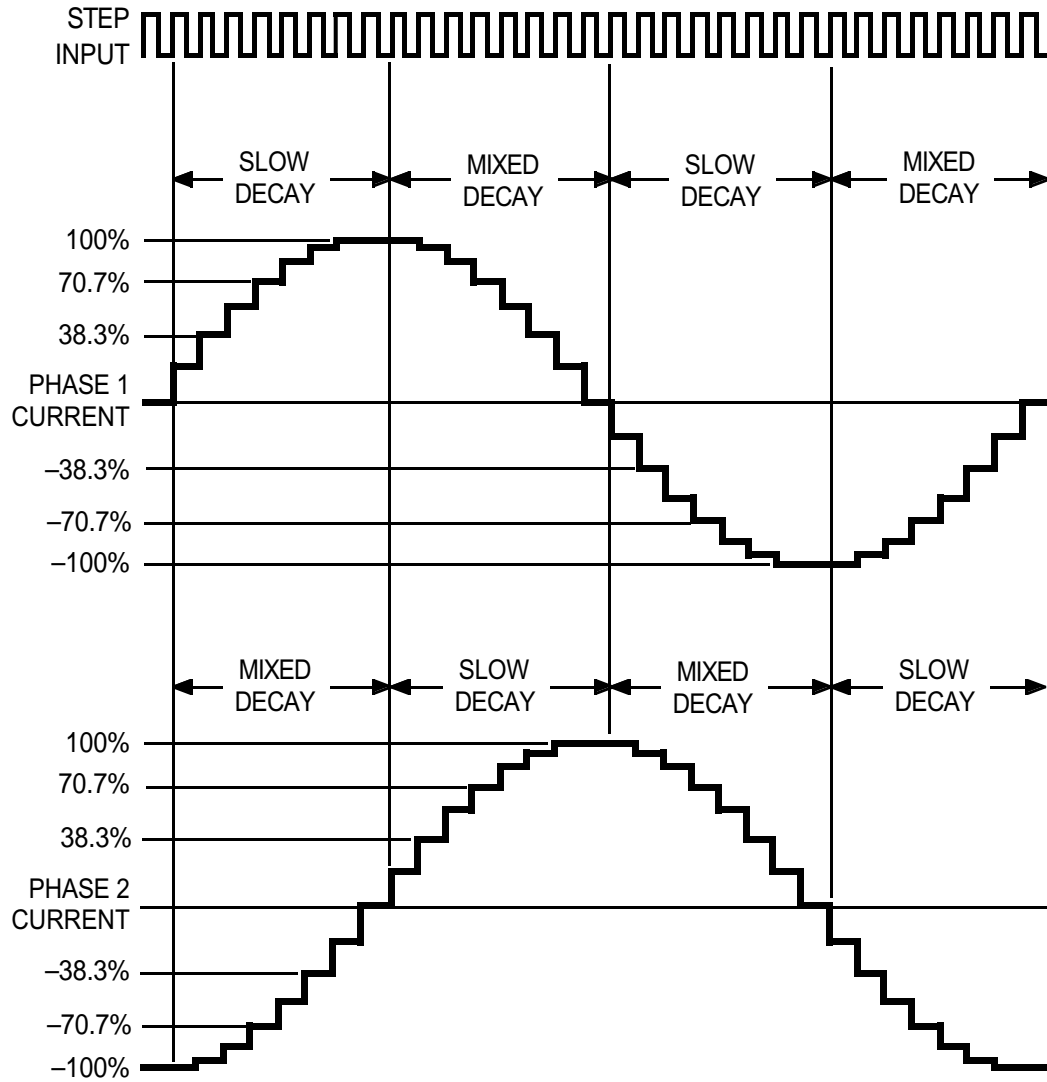

Dwg. WK-004-16

The mixed-decay mode is controlled by the percent fast decay voltage ( $V_{PFD}$ ). If the voltage at the PFD input is greater than  $0.6V_{CC}$  then slow-decay mode is selected. If the voltage on the PFD input is less than  $0.21V_{CC}$  then fast-decay mode is selected. Mixed decay is between these two levels.

**3967**  
**MICROSTEPPING DRIVER**  
**WITH TRANSLATOR**

**Terminal List**

<b>Terminal Name</b>	<b>Terminal Description</b>	<b>Terminal Number</b>
REF	Gm reference input	1
RC2	Analog input for fixed offtime – bridge 2	2
SLEEP	Logic input	3
OUT2B	H bridge 2 output B	4
LOAD SUPPLY2	VBB2, the load supply for bridge 2	5
GND	Analog and power ground	6, 7
SENSE2	Sense resistor for bridge 2	8
OUT2A	H bridge 2 output A	9
STEP	Logic input	10
DIR	Logic Input	11
MS1	Logic input	12
MS2	Logic input	13
LOGIC SUPPLY	VCC, the logic supply voltage	14
ENABLE	Logic input	15
OUT1A	H bridge 1 output A	16
SENSE1	Sense resistor for bridge 1	17
GND	Analog and power ground	18, 19
LOAD SUPPLY1	VBB1, the load supply for bridge 1	20
OUT1B	H bridge 1 output B	21
RESET	Logic input	22
RC1	Analog Input for fixed offtime – bridge 1	23
PFD	Mixed decay setting	24

# 3967 MICROSTEPPING DRIVER WITH TRANSLATOR

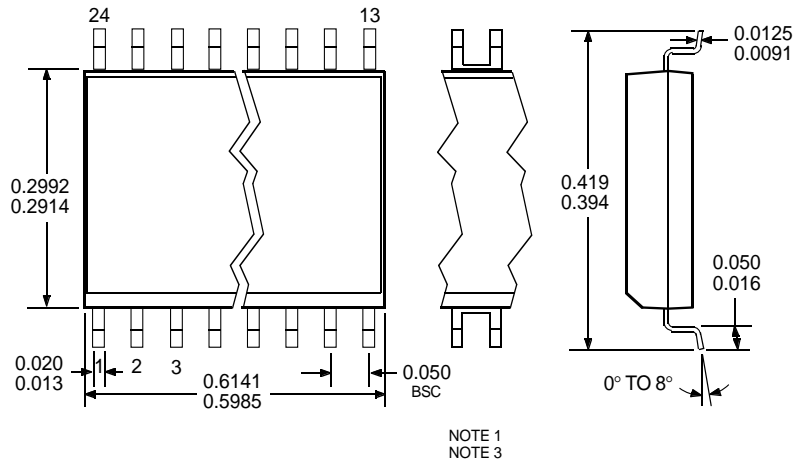

**Dimensions in Inches**  
(for reference only)

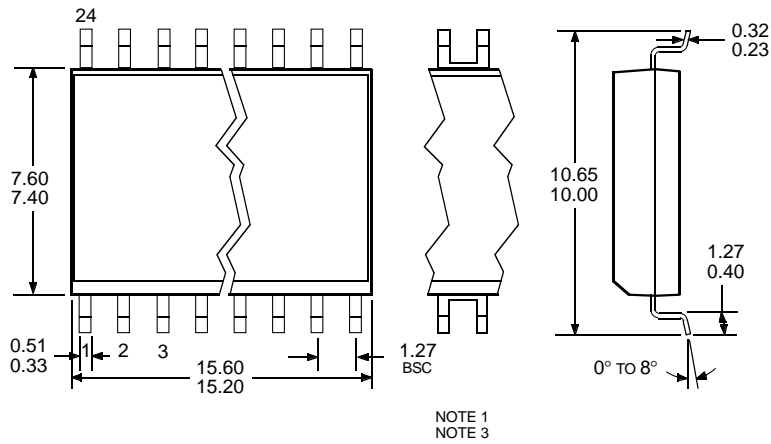
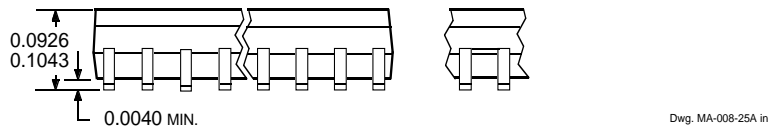

**Dimensions in Millimeters**  
(controlling dimensions)

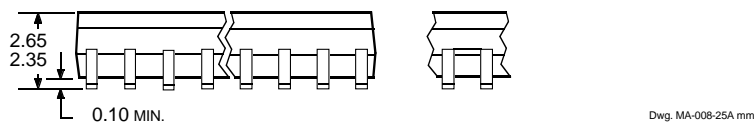

- NOTES: 1. Exact body and lead configuration at vendor's option within limits shown.  
 2. Lead spacing tolerance is non-cumulative.  
 3. Webbed lead frame. Leads 6, 7, 18, and 19 are internally one piece.  
 4. Supplied in standard sticks/tubes of 31 devices or add "TR" to part number for tape and reel.

**3967**  
**MICROSTEPPING DRIVER**  
**WITH TRANSLATOR**

*The products described here are manufactured under one or more U.S. patents or U.S. patents pending.*

*Allegro MicroSystems, Inc. reserves the right to make, from time to time, such departures from the detail specifications as may be required to permit improvements in the performance, reliability, or manufacturability of its products. Before placing an order, the user is cautioned to verify that the information being relied upon is current.*

*Allegro products are not authorized for use as critical components in life-support devices or systems without express written approval.*

*The information included herein is believed to be accurate and reliable. However, Allegro MicroSystems, Inc. assumes no responsibility for its use; nor for any infringement of patents or other rights of third parties which may result from its use.*