

- Bidirectional Bus Transceivers in High-Density 20-Pin Packages
- Hysteresis at Bus Inputs Improves Noise Margins
- Choice of True or Inverting Logic
- A Bus Outputs are Open-Collector, B Bus Outputs are 3-State

description

These octal bus transceivers are designed for asynchronous two-way communication between open-collector and 3-state buses. The devices transmit data from the A bus (open-collector) to the B bus (3-state) or from the B bus to the A bus depending upon the level at the direction control (DIR) input. The enable input (\bar{G}) can be used to disable the device so the buses are isolated.

FUNCTION TABLE

CONTROL INPUTS		OPERATION	
\bar{G}	DIR	'LS638	'LS639
L	L	B data to A bus	B data to A bus
L	H	A data to B bus	A data to B bus
H	X	Isolation	Isolation

H = high level, L = low level, X = irrelevant

DEVICE	A OUTPUT	B OUTPUT	LOGIC
'LS638	Open-Collector	3-State	Inverting
'LS639	Open-Collector	3-State	True

SN54LS638, SN54LS639 . . . J PACKAGE
SN74LS638, SN74LS639 . . . DW OR N PACKAGE
(TOP VIEW)

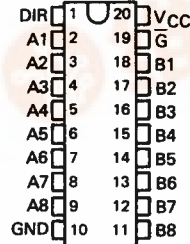

SN54LS638, SN54LS639 . . . FK PACKAGE
(TOP VIEW)

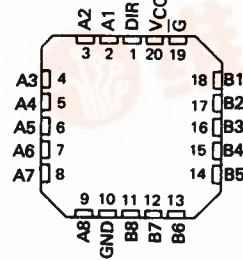

schematics of inputs and outputs

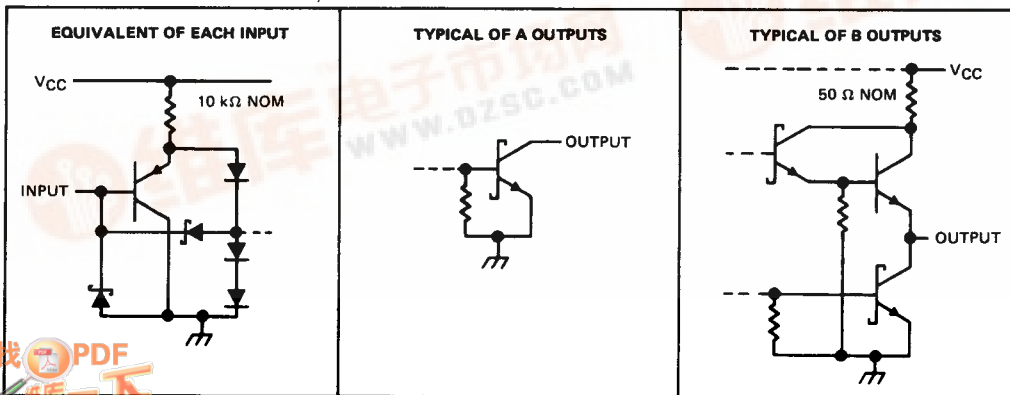

SN54LS638, SN54LS639, SN74LS638, SN74LS639 OCTAL BUS TRANSCEIVERS

logic symbols†

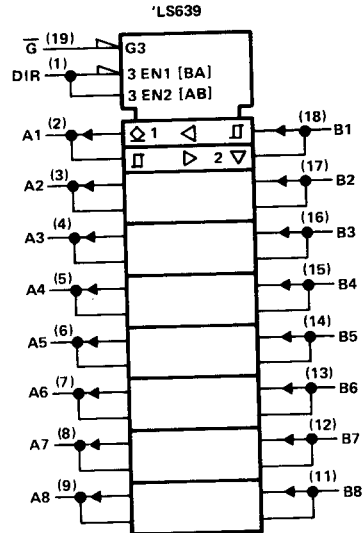
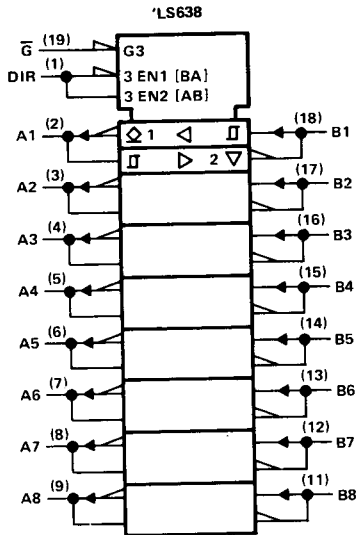

† These symbols are in accordance with ANSI/IEEE Std 91-1984 and IEC Publication 617-12.
Pin numbers shown are for DW, J, and N packages.

logic diagrams (positive logic)

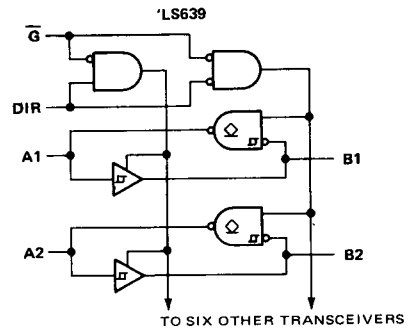
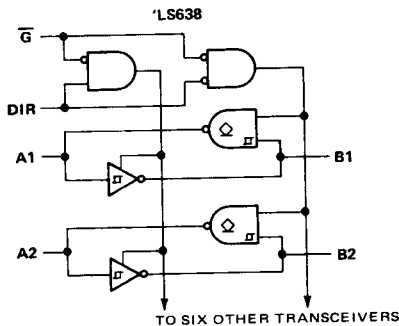

absolute maximum ratings over operating free-air temperature range (unless otherwise noted)

Supply voltage, V_{CC} (see Note 1)	7 V
Input voltage (DIR or \bar{G})	7 V
Off-state output voltage (A or B)	5.5 V
Operating free-air temperature range:	
SN54LS638, SN54LS639	-55°C to 125°C
SN74LS638, SN74LS639	0°C to 70°C
Storage temperature range	-65°C to 150°C

NOTE 1: Voltage values are with respect to the network ground terminal.

2

TTL Devices

SN54LS638, SN54LS639, SN74LS638, SN74LS639 OCTAL BUS TRANSCEIVERS

recommended operating conditions

	SN54LS*			SN74LS*			UNIT
	MIN	NOM	MAX	MIN	NOM	MAX	
Supply voltage, V_{CC}	4.5	5	5.5	4.75	5	5.25	V
High-level output voltage, V_{OH} (A bus)	5.5			5.5			V
High-level output current, I_{OH} (B bus)	-12			-15			mA
Low-level output current, I_{OL} (A or B bus)	12			24			mA
Operating free-air temperature, T_A	-55			125			°C

electrical characteristics over recommended operating free-air temperature range (unless otherwise noted)

PARAMETER	TEST CONDITIONS†	SN54LS'			SN74LS'			UNIT
		MIN	TYP‡	MAX	MIN	TYP‡	MAX	
V_{IH} High-level input voltage		2			2			V
V_{IL} Low-level input voltage			0.5			0.6		V
V_{IK} Input clamp voltage	$V_{CC} = \text{MIN}, I_I = -18 \text{ mA}$			-1.5			-1.5	V
Hysteresis ($V_{T+} - V_{T-}$)	$V_{CC} = \text{MIN}$	0.1	0.4		0.2	0.4		V
I_{OH} High-level output current	A $V_{CC} = \text{MIN}, V_{IH} = 2 \text{ V}, V_{IL} = \text{MAX}, V_{OH} = 5.5 \text{ V}$			0.1			0.1	mA
V_{OH} High-level output voltage	B $V_{CC} = \text{MIN}, V_{IH} = 2 \text{ V}, V_{IL} = \text{MAX}$	2.4			2.4			V
V_{OL} Low-level output voltage	A or B $V_{CC} = \text{MIN}, V_{IH} = 2 \text{ V}, V_{IL} = \text{MAX}$		0.25	0.4		0.25	0.4	V
I_{OZH} Off-state output current, high-level voltage applied	B $V_{CC} = \text{MAX}, \bar{G}$ at 2 V, $V_O = 2.7 \text{ V}$			20			20	µA
I_{OZL} Off-state output current, low-level voltage applied	A or B $V_{CC} = \text{MAX}, \bar{G}$ at 2 V, $V_O = 0.4 \text{ V}$			-0.4			-0.4	mA
I_I Input current at maximum input voltage	A or B DIR or \bar{G} $V_{CC} = \text{MAX}$			0.1			0.1	mA
I_{IH} High-level input current	$V_{CC} = \text{MAX}, V_I = 2.7 \text{ V}$			20			20	µA
I_{IL} Low-level input current	$V_{CC} = \text{MAX}, V_I = 0.4 \text{ V}$			-0.4			-0.4	mA
I_{OS} Short-circuit output current§	B $V_{CC} = \text{MAX}$	-40		-225	-40		-225	mA
I_{CCH} Supply current, outputs high	$V_{CC} = \text{MAX}, \text{Outputs open}$		48	70		48	70	mA
I_{CCL} Supply current, outputs low	$V_{CC} = \text{MAX}, \text{Outputs open}$		62	90		62	90	mA
I_{CCZ} Supply current, outputs off	$V_{CC} = \text{MAX}, \text{Outputs open}$		64	95		64	95	mA

† For conditions shown as MIN or MAX, use the appropriate value specified under recommended operating conditions.

‡ All typical values are at $V_{CC} = 5 \text{ V}, T_A = 25^\circ \text{C}$.

§ Not more than one output should be shorted at a time, and duration of the short circuit should not exceed one second.

switching characteristics, $V_{CC} = 5 \text{ V}, T_A = 25^\circ \text{C}$, see note 2

PARAMETER	FROM (INPUT)	TO (OUTPUT)	TEST CONDITIONS	'LS638		'LS639		UNIT
				MIN	TYP	MAX	MIN	
t_{PLH}	A	B	$C_L = 45 \text{ pF}, R_L = 667 \Omega$	6	10	8	15	ns
	B	A		17	25	19	25	
t_{PHL}	A	B		8	15	11	15	ns
	B	A		14	25	16	25	
t_{PLH}	\bar{G}	A		26	40	23	40	ns
t_{PHL}	\bar{G}	A		43	60	34	50	ns
t_{PZH}	\bar{G}	B		23	40	26	40	ns
t_{PZL}	\bar{G}	B		31	40	31	40	ns
t_{PHZ}	\bar{G}	B		15	25	15	25	ns
t_{PLZ}	\bar{G}	B		15	25	15	25	ns

NOTE 2: Load circuits and voltage waveforms are shown in Section 1.