

1.5-A PEAK BOOST/BUCK/INVERTING SWITCHING REGULATORS

SLLS636D – DECEMBER 2004 – REVISED MARCH 2005

- Wide Input Voltage Range . . . 3 V to 40 V
- High Output Switch Current . . . Up to 1.5 A
- Adjustable Output Voltage
- Oscillator Frequency . . . Up to 100 kHz
- Precision Internal Reference . . . 2%
- Short-Circuit Current Limiting
- Low Standby Current

D (SOIC) OR P (PDIP) PACKAGE
(TOP VIEW)

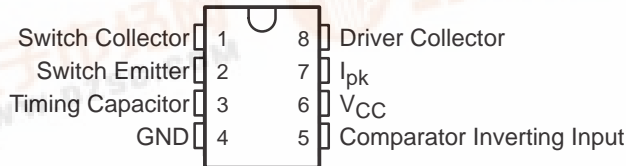

DRJ (QFN) PACKAGE
(TOP VIEW)

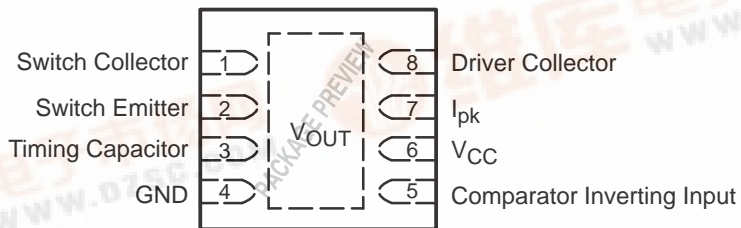

description/ordering information

The MC33063A and MC34063A are easy-to-use ICs containing all the primary circuitry needed for building simple dc-dc converters. These devices primarily consist of an internal temperature-compensated reference, a comparator, an oscillator, a PWM controller with active current limiting, a driver, and a high-current output switch; thus, the devices require minimal external components to build converters in the boost, buck, and inverting topologies.

The MC33063A is characterized for operation from -40°C to 85°C , while the MC34063A is characterized for operation from 0°C to 70°C .

ORDERING INFORMATION

TA	PACKAGE†		ORDERABLE PART NUMBER	TOP-SIDE MARKING
-40°C to 85°C	PDIP (P)	Tube of 50	MC33063AP	MC33063AP
	QFN (DRJ)	Reel of 1000	MC33063ADRJR	PREVIEW
	SOIC (D)	Tube of 75	MC33063AD	M33063A
		Reel of 2500	MC33063ADR	
0°C to 70°C	PDIP (P)	Tube of 50	MC34063AP	MC34063AP
	QFN (DRJ)	Reel of 1000	MC34063ADRJR	PREVIEW
	SOIC (D)	Tube of 75	MC34063AD	M34063A
		Reel of 2500	MC34063ADR	

† Package drawings, standard packing quantities, thermal data, symbolization, and PCB design guidelines are available at www.ti.com/sc/package.

Please be aware that an important notice concerning availability, standard warranty, and use in critical applications of Texas Instruments semiconductor products and disclaimers thereto appears at the end of this data sheet.

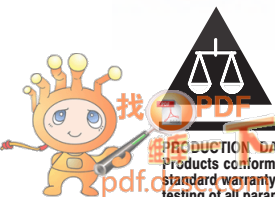

MC33063A, MC34063A

1.5-A PEAK BOOST/BUCK/INVERTING SWITCHING REGULATORS

SLLS636D – DECEMBER 2004 – REVISED MARCH 2005

functional block diagram

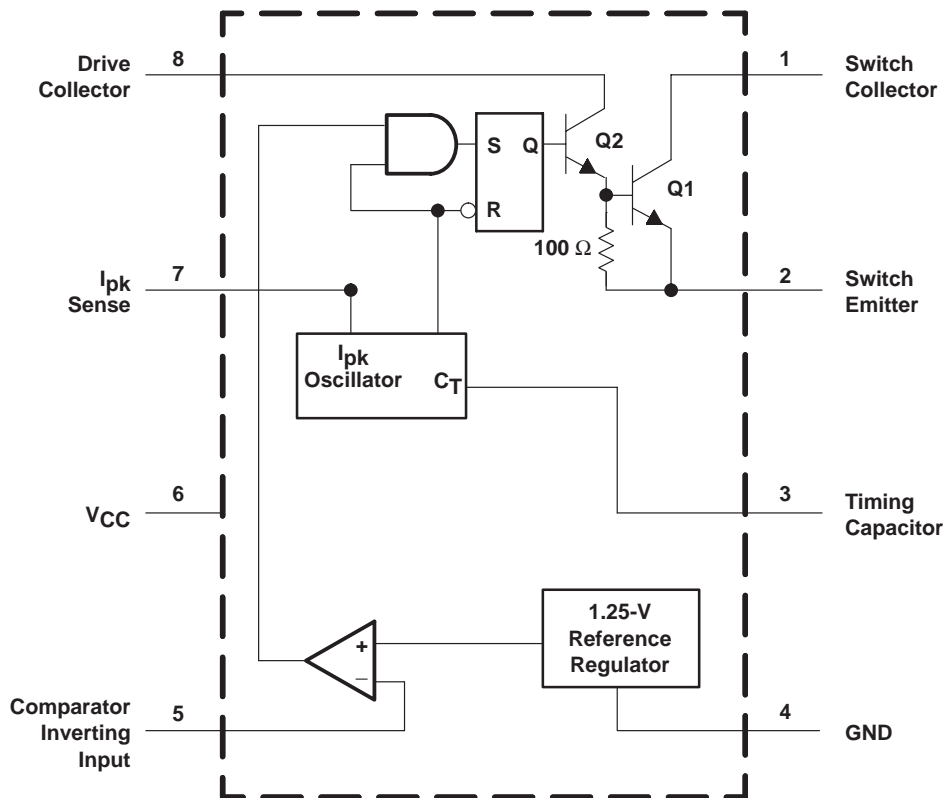

absolute maximum ratings over operating free-air temperature range (unless otherwise noted)†

Supply voltage, V_{CC}	40 V
Comparator Inverting Input voltage range, V_{IR}	-0.3 V to 40 V
Switch Collector voltage, $V_{C(\text{switch})}$	40V
Switch Emitter voltage ($V_{PIN1} = 40\text{ V}$), $V_{E(\text{switch})}$	40V
Switch Collector to Switch Emitter voltage, $V_{CE(\text{switch})}$	40V
Driver Collector voltage, $V_{C(\text{driver})}$	40V
Driver Collector current, $I_{C(\text{driver})}$	100 mA
Switch current, I_{SW}	1.5 A
Package thermal impedance, θ_{JA} (see Notes 1 and 2):	
D package	97°C/W
DRJ package	TBD°C/W
P package	85°C/W
Operating virtual junction temperature, T_J	150°C
Storage temperature range, T_{stg}	-65°C to 150°C

† Stresses beyond those listed under “absolute maximum ratings” may cause permanent damage to the device. These are stress ratings only, and functional operation of the device at these or any other conditions beyond those indicated under “recommended operating conditions” is not implied. Exposure to absolute-maximum-rated conditions for extended periods may affect device reliability.

- NOTES: 1. Maximum power dissipation is a function of $T_J(\text{max})$, θ_{JA} , and T_A . The maximum allowable power dissipation at any allowable ambient temperature is $P_D = (T_J(\text{max}) - T_A)/\theta_{JA}$. Operating at the absolute maximum T_J of 150°C can affect reliability.
2. The package thermal impedance is calculated in accordance with JESD 51-7.

MC33063A, MC34063A

1.5-A PEAK BOOST/BUCK/INVERTING SWITCHING REGULATORS

SLLS636D – DECEMBER 2004 – REVISED MARCH 2005

recommended operating conditions

		MIN	MAX	UNIT	
V _{CC}	Supply voltage	3	40	V	
T _A	Operating free-air temperature range	MC33063A	-40	85	°C
		MC34063A	0	70	

electrical characteristics, V_{CC} = 5 V, T_A = full operating range (unless otherwise noted) (see block diagram)

OSCILLATOR

PARAMETER	TEST CONDITIONS	T _A	MIN	TYP	MAX	UNIT	
f _{osc}	Oscillator frequency	V _{PIN5} = 0 V, C _T = 1 nF	25°C	24	33	42	kHz
I _{chg}	Charge current	V _{CC} = 5 V to 40 V	25°C	24	35	42	μA
I _{dischg}	Discharge current	V _{CC} = 5 V to 40 V	25°C	140	220	260	μA
I _{dischg} /I _{chg}	Discharge-to-charge current ratio	V _{PIN7} = V _{CC}	25°C	5.2	6.5	7.5	
V _{Ipk}	Current-limit sense voltage	I _{dischg} = I _{chg}	25°C	250	300	350	mV

OUTPUT SWITCH (see Note 3)

PARAMETER	TEST CONDITIONS	T _A	MIN	TYP	MAX	UNIT
V _{CE(sat)}	Saturation voltage – Darlington connection	I _{SW} = 1 A, pins 1 and 8 connected	Full range	1	1.3	V
V _{CE(sat)}	Saturation voltage – non-Darlington connection (see Note 4)	I _{SW} = 1 A, R _{PIN8} = 82 Ω to V _{CC} , forced β ~ 20	Full range	0.45	0.7	V
h _{FE}	DC current gain	I _{SW} = 1 A, V _{CE} = 5 V	25°C	50	75	
I _{C(off)}	Collector off-state current	V _{CE} = 40 V	Full range	0.01	100	μA

NOTES: 3. Low duty-cycle pulse testing is used to maintain junction temperature as close to ambient temperature as possible.

4. In the non-Darlington configuration, if the output switch is driven into hard saturation at low switch currents (≤300 mA) and high driver currents (≥30 mA), it may take up to 2 μs for the switch to come out of saturation. This condition effectively shortens the off time at frequencies ≥30 kHz, becoming magnified as temperature increases. The following output drive condition is recommended in the non-Darlington configuration:

$$\text{Forced } \beta \text{ of output switch} = I_{C,SW} / (I_{C,driver} - 7 \text{ mA}) \geq 10,$$

where ~ 7 mA is required by the 100-Ω resistor in the emitter of the driver to forward bias the V_{be} of the switch.

COMPARATOR

PARAMETER	TEST CONDITIONS	T _A	MIN	TYP	MAX	UNIT
V _{th}	Threshold voltage	25°C	1.225	1.25	1.275	V
		Full range	1.21		1.29	
ΔV _{th}	Threshold-voltage line regulation	V _{CC} = 5 V to 40 V	Full range	1.4	5	mV
I _{IB}	Input bias current	V _{IN} = 0 V	Full range	-20	-400	nA

TOTAL DEVICE

PARAMETER	TEST CONDITIONS	T _A	MIN	MAX	UNIT	
I _{CC}	Supply current	V _{CC} = 5 V to 40 V, C _T = 1 nF, V _{PIN7} = V _{CC} , V _{PIN5} > V _{th} , V _{PIN2} = GND, all other pins open	Full range	4		mA

MC33063A, MC34063A

1.5-A PEAK BOOST/BUCK/INVERTING SWITCHING REGULATORS

SLLS636D – DECEMBER 2004 – REVISED MARCH 2005

TYPICAL CHARACTERISTICS

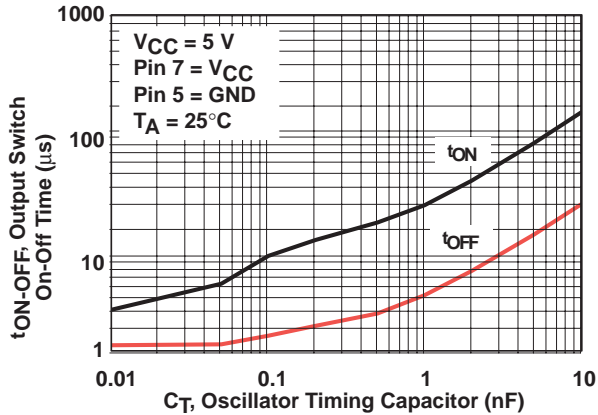

Figure 1. Output Switch On-Off Time vs Oscillator Timing Capacitor

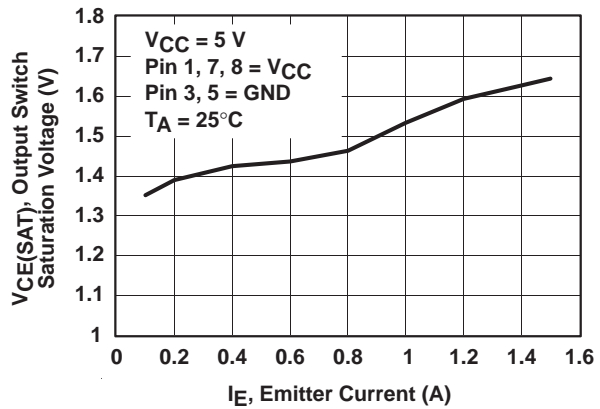

Figure 2. Output Switch Saturation Voltage vs Emitter Current (Emitter-Follower Configuration)

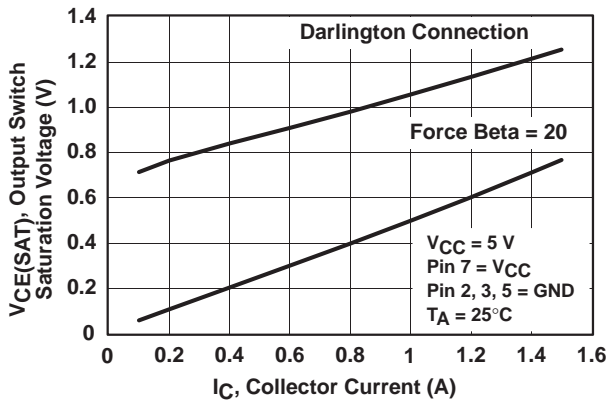

Figure 3. Output Switch Saturation Voltage vs Collector Current (Common-Emitter Configuration)

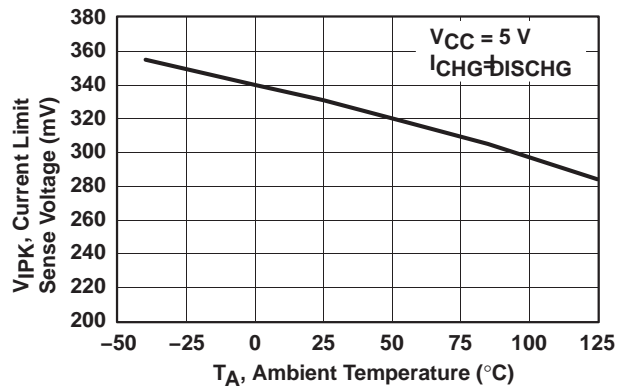

Figure 4. Current-Limit Sense Voltage vs Temperature

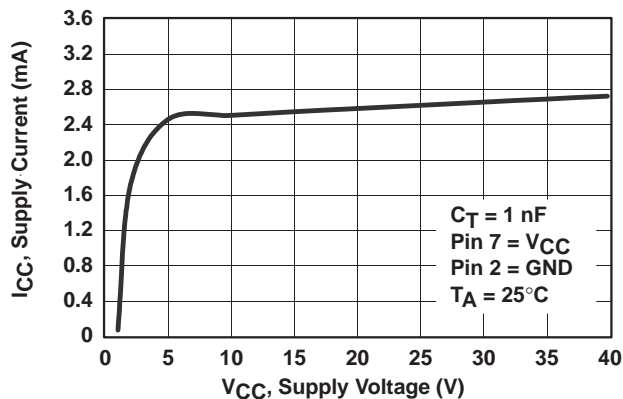

Figure 5. Standby Supply Current vs Supply Voltage

MC33063A, MC34063A

1.5-A PEAK BOOST/BUCK/INVERTING SWITCHING REGULATORS

SLLS636D – DECEMBER 2004 – REVISED MARCH 2005

TYPICAL CHARACTERISTICS

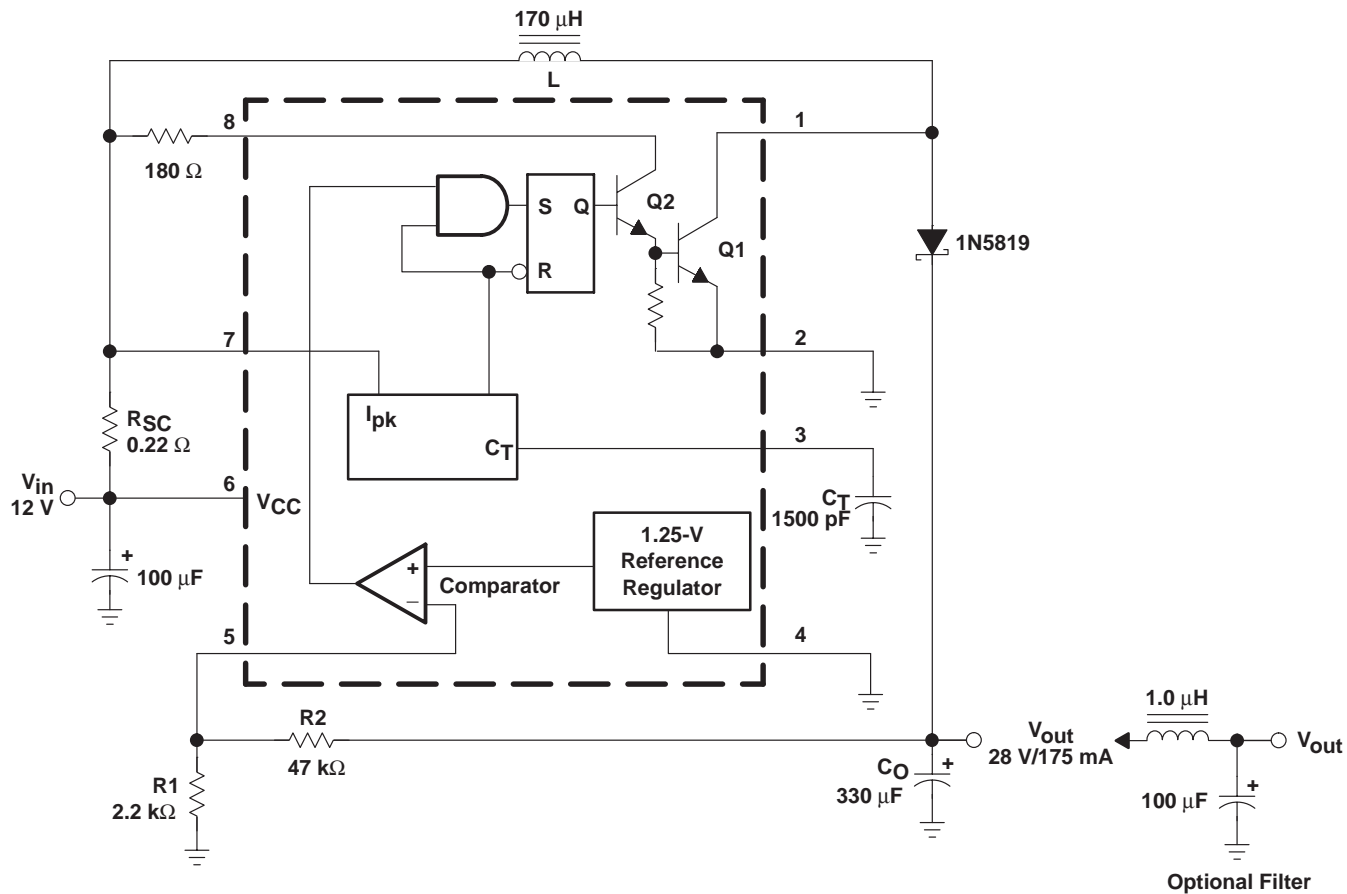

TEST	CONDITIONS	RESULTS
Line Regulation	$V_{IN} = 8\text{ V to }16\text{ V}, I_O = 175\text{ mA}$	$30\text{ mV} \pm 0.05\%$
Load Regulation	$V_{IN} = 12\text{ V}, I_O = 75\text{ mA to }175\text{ mA}$	$10\text{ mV} \pm 0.017\%$
Output Ripple	$V_{IN} = 12\text{ V}, I_O = 175\text{ mA}$	400 mV_{pp}
Efficiency	$V_{IN} = 12\text{ V}, I_O = 175\text{ mA}$	87.7%
Output Ripple With Optional Filter	$V_{IN} = 12\text{ V}, I_O = 175\text{ mA}$	40 mV_{pp}

Figure 6. Step-Up Converter

MC33063A, MC34063A

1.5-A PEAK BOOST/BUCK/INVERTING SWITCHING REGULATORS

SLLS636D – DECEMBER 2004 – REVISED MARCH 2005

TYPICAL CHARACTERISTICS

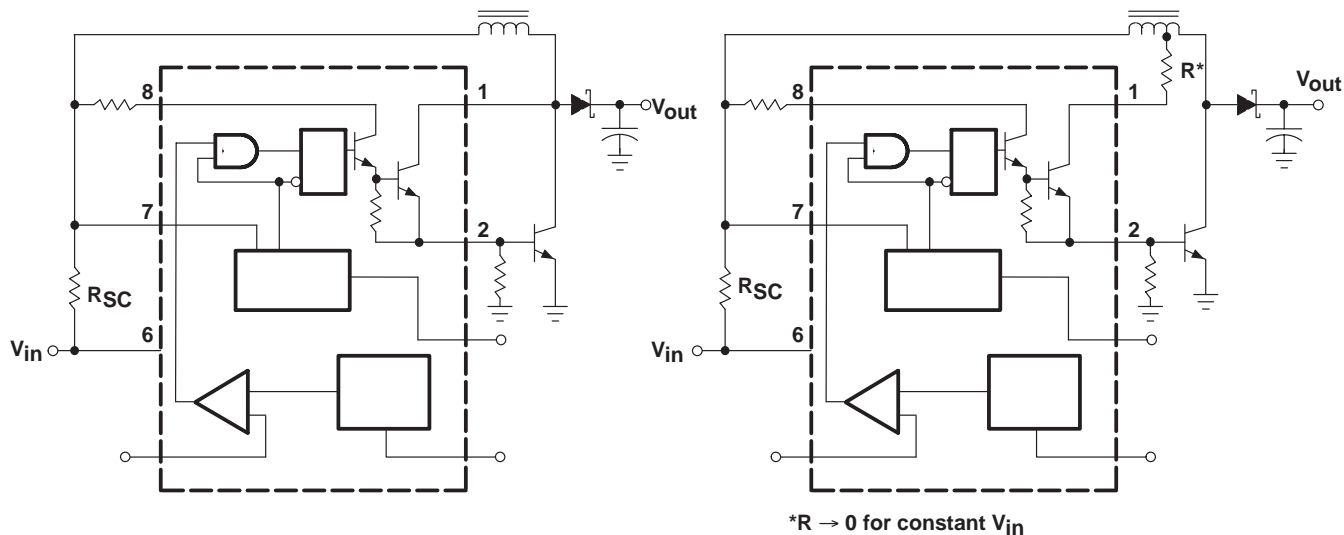

2a. External npn Switch

2b. External pnp Saturated Switch (see Note 5)

NOTE A: If the output switch is driven into hard saturation (non-Darlington configuration) at low switch currents (≤ 300 mA) and high driver currents (≥ 30 mA), it may take up to $2 \mu\text{s}$ to come out of saturation. This condition will shorten the off time at frequencies ≥ 30 kHz and is magnified at high temperatures. This condition does not occur with a Darlington configuration because the output switch cannot saturate. If a non-Darlington configuration is used, the output drive configuration in Figure 2b is recommended.

Figure 7. External Current-Boost Connections for I_C Peak Greater Than 1.5 A

MC33063A, MC34063A

1.5-A PEAK BOOST/BUCK/INVERTING SWITCHING REGULATORS

SLLS636D – DECEMBER 2004 – REVISED MARCH 2005

TYPICAL CHARACTERISTICS

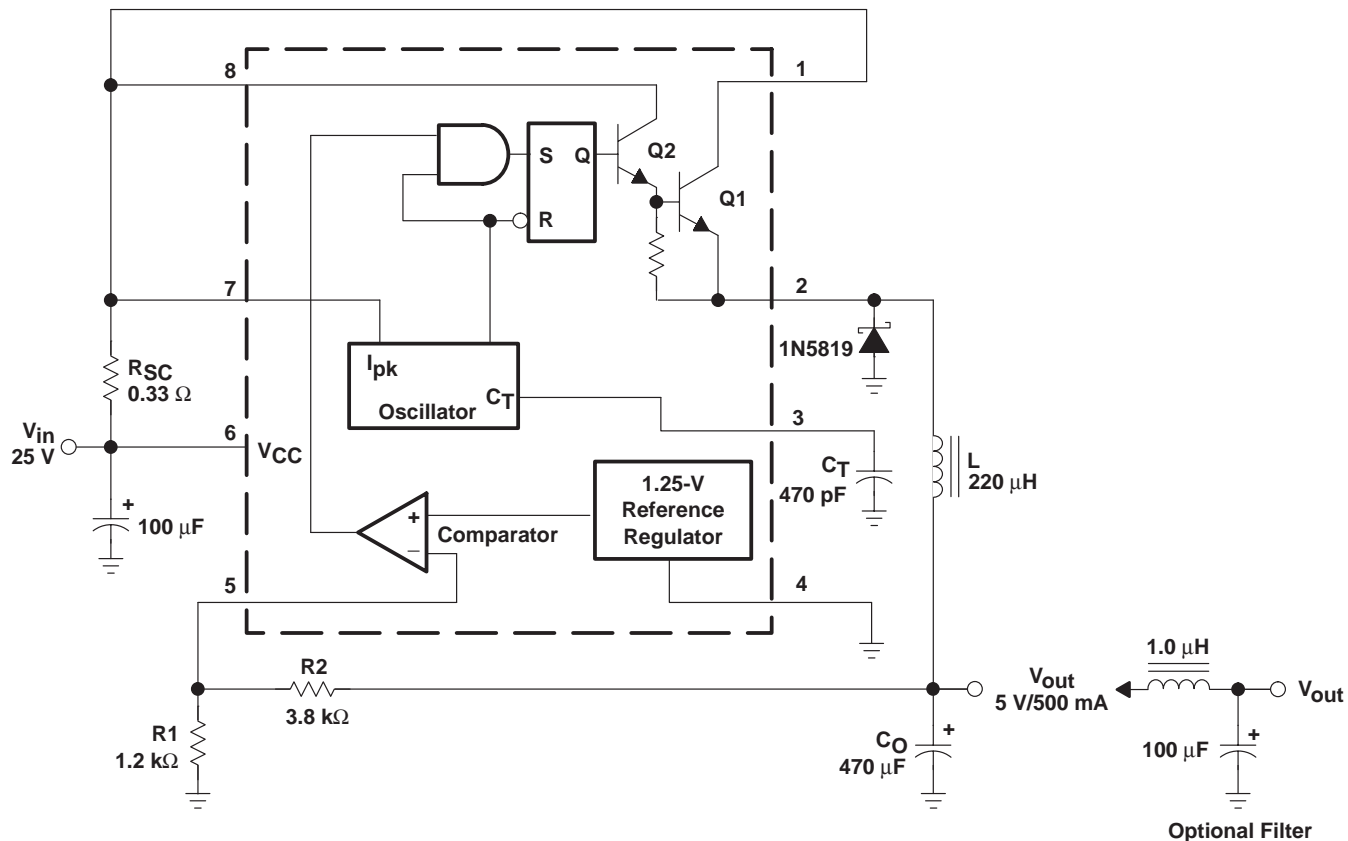

TEST	CONDITIONS	RESULTS
Line Regulation	$V_{IN} = 15 \text{ V to } 25 \text{ V}, I_O = 500 \text{ mA}$	$12 \text{ mV} \pm 0.12\%$
Load Regulation	$V_{IN} = 25 \text{ V}, I_O = 50 \text{ mA to } 500 \text{ mA}$	$3 \text{ mV} \pm 0.03\%$
Output Ripple	$V_{IN} = 25 \text{ V}, I_O = 500 \text{ mA}$	120 mV_{PP}
Short-Circuit Current	$V_{IN} = 25 \text{ V}, R_L = 0.1 \Omega$	1.1 A
Efficiency	$V_{IN} = 25 \text{ V}, I_O = 500 \text{ mA}$	83.7%
Output Ripple With Optional Filter	$V_{IN} = 25 \text{ V}, I_O = 500 \text{ mA}$	40 mV_{PP}

Figure 8. Step-Down Converter

MC33063A, MC34063A 1.5-A PEAK BOOST/BUCK/INVERTING SWITCHING REGULATORS

SLLS636D – DECEMBER 2004 – REVISED MARCH 2005

TYPICAL CHARACTERISTICS

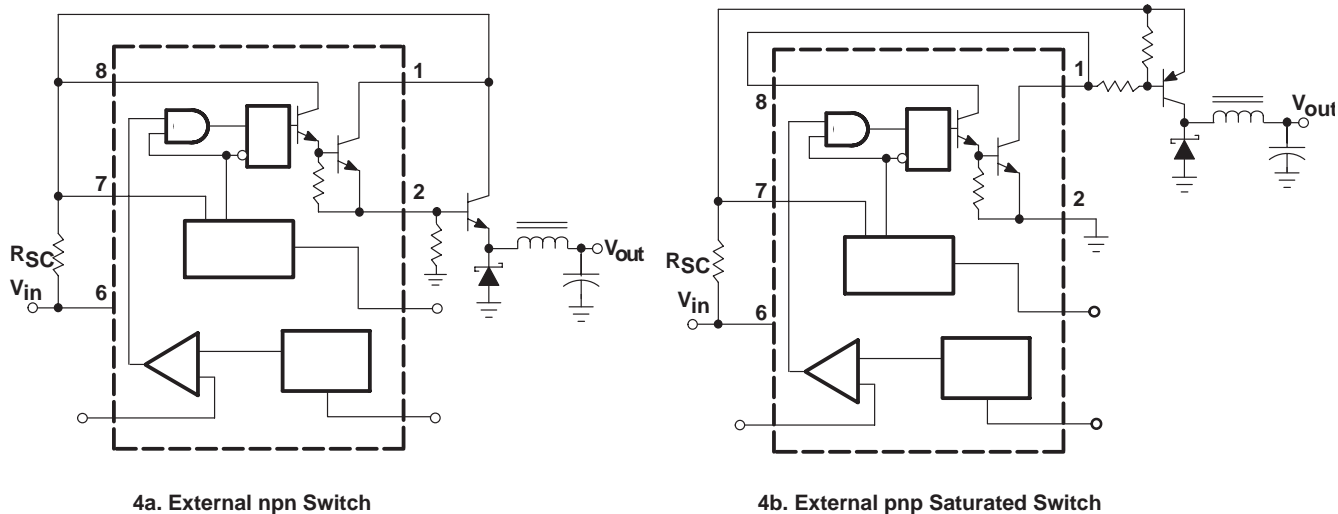

Figure 9. External Current-Boost Connections for I_C Peak Greater Than 1.5 A

MC33063A, MC34063A

1.5-A PEAK BOOST/BUCK/INVERTING SWITCHING REGULATORS

SLLS636D – DECEMBER 2004 – REVISED MARCH 2005

TYPICAL CHARACTERISTICS

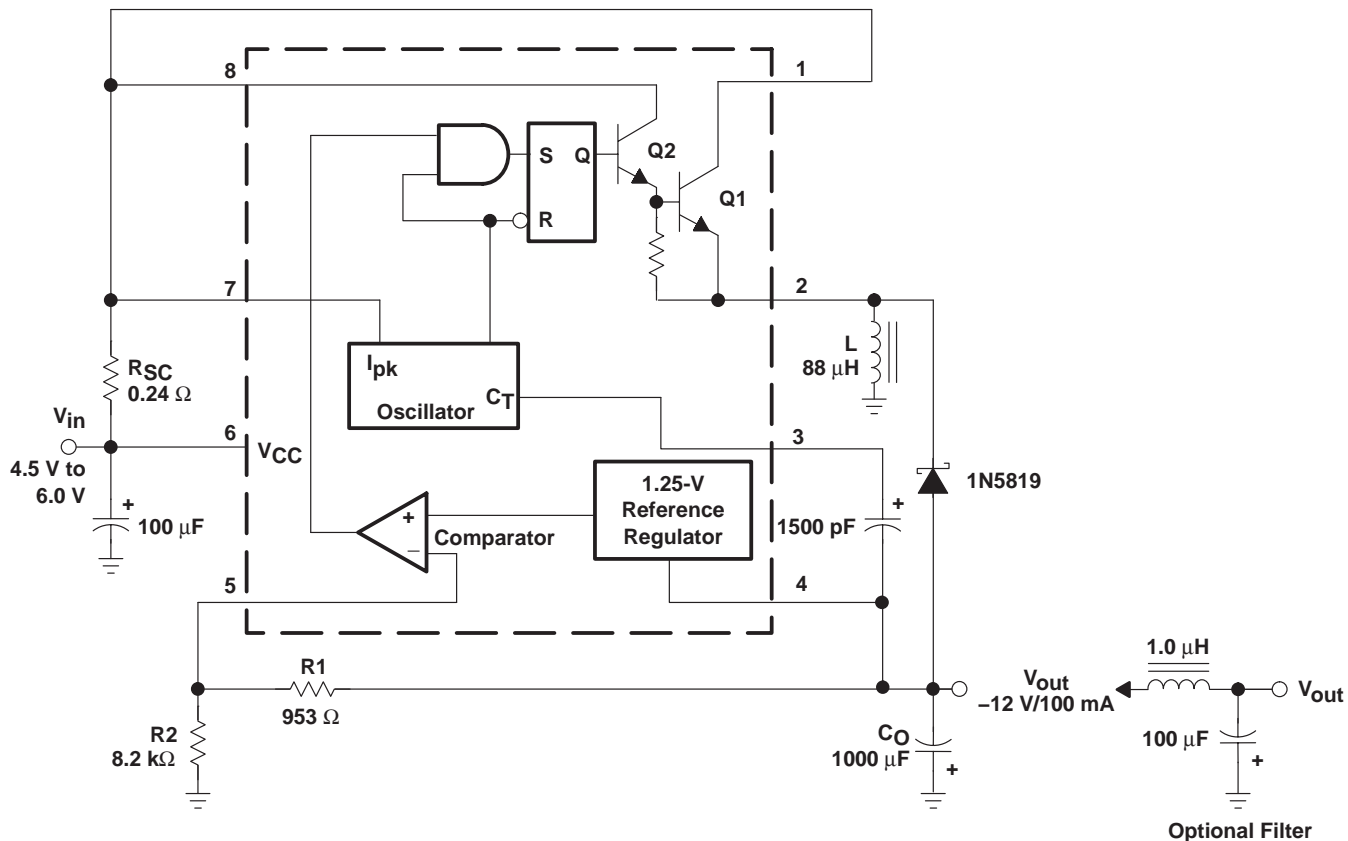

TEST	CONDITIONS	RESULTS
Line Regulation	$V_{IN} = 4.5 \text{ V to } 6 \text{ V}, I_O = 100 \text{ mA}$	$3 \text{ mV} \pm 0.12\%$
Load Regulation	$V_{IN} = 5 \text{ V}, I_O = 10 \text{ mA to } 100 \text{ mA}$	$0.022 \text{ V} \pm 0.09\%$
Output Ripple	$V_{IN} = 5 \text{ V}, I_O = 100 \text{ mA}$	500 mV_{PP}
Short-Circuit Current	$V_{IN} = 5 \text{ V}, R_L = 0.1 \Omega$	910 mA
Efficiency	$V_{IN} = 5 \text{ V}, I_O = 100 \text{ mA}$	62.2%
Output Ripple With Optional Filter	$V_{IN} = 5 \text{ V}, I_O = 100 \text{ mA}$	70 mV_{PP}

Figure 10. Voltage-Inverting Converter

MC33063A, MC34063A 1.5-A PEAK BOOST/BUCK/INVERTING SWITCHING REGULATORS

SLLS636D – DECEMBER 2004 – REVISED MARCH 2005

TYPICAL CHARACTERISTICS

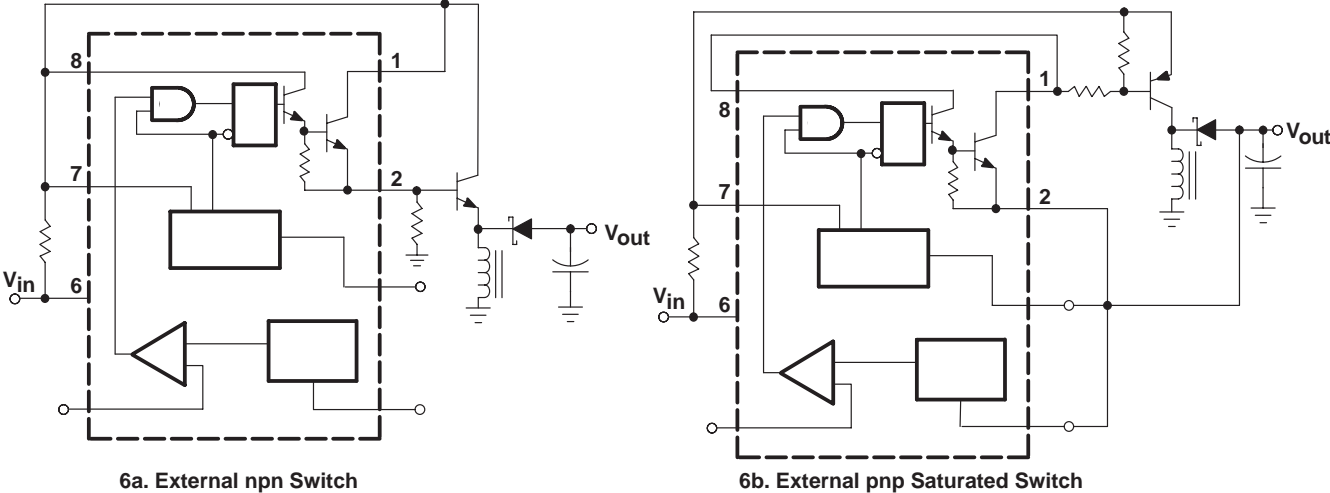

Figure 11. External Current-Boost Connections for I_C Peak Greater Than 1.5 A

MC33063A, MC34063A

1.5-A PEAK BOOST/BUCK/INVERTING SWITCHING REGULATORS

SLLS636D – DECEMBER 2004 – REVISED MARCH 2005

APPLICATION INFORMATION

calculations of key parameters

CALCULATION	STEP UP	STEP DOWN	VOLTAGE INVERTING
t_{on}/t_{off}	$\frac{V_{out} + V_F - V_{in(min)}}{V_{in(min)} - V_{sat}}$	$\frac{V_{out} + V_F}{V_{in(min)} - V_{sat} - V_{out}}$	$\frac{ V_{out} + V_F}{V_{in} - V_{sat}}$
$(t_{on} + t_{off})$	$\frac{1}{f}$	$\frac{1}{f}$	$\frac{1}{f}$
t_{off}	$\frac{t_{on} + t_{off}}{\frac{t_{on}}{t_{off}} + 1}$	$\frac{t_{on} + t_{off}}{\frac{t_{on}}{t_{off}} + 1}$	$\frac{t_{on} + t_{off}}{\frac{t_{on}}{t_{off}} + 1}$
t_{on}	$(t_{on} + t_{off}) - t_{off}$	$(t_{on} + t_{off}) - t_{off}$	$(t_{on} + t_{off}) - t_{off}$
C_T	$4 \times 10^{-5} t_{on}$	$4 \times 10^{-5} t_{on}$	$4 \times 10^{-5} t_{on}$
$I_{pk(switch)}$	$2I_{out(max)} \left(\frac{t_{on}}{t_{off}} + 1 \right)$	$2I_{out(max)}$	$2I_{out(max)} \left(\frac{t_{on}}{t_{off}} + 1 \right)$
R_{sc}	$\frac{0.3}{I_{pk(switch)}}$	$\frac{0.3}{I_{pk(switch)}}$	$\frac{0.3}{I_{pk(switch)}}$
$L_{(min)}$	$\left(\frac{(V_{in(min)} - V_{sat})}{I_{pk(switch)}} \right) t_{on(max)}$	$\left(\frac{(V_{in(min)} - V_{sat} - V_{out})}{I_{pk(switch)}} \right) t_{on(max)}$	$\left(\frac{(V_{in(min)} - V_{sat})}{I_{pk(switch)}} \right) t_{on(max)}$
C_O	$9 \frac{I_{out} t_{on}}{V_{ripple(pp)}}$	$\frac{I_{pk(switch)} (t_{on} + t_{off})}{8V_{ripple(pp)}}$	$9 \frac{I_{out} t_{on}}{V_{ripple(pp)}}$

PACKAGING INFORMATION

Orderable Device	Status ⁽¹⁾	Package Type	Package Drawing	Pins	Package Qty	Eco Plan ⁽²⁾	Lead/Ball Finish	MSL Peak Temp ⁽³⁾
MC33063AD	ACTIVE	SOIC	D	8	75	Pb-Free (RoHS)	CU NIPDAU	Level-2-260C-1 YEAR/ Level-1-235C-UNLIM
MC33063ADR	ACTIVE	SOIC	D	8	2500	Pb-Free (RoHS)	CU NIPDAU	Level-2-260C-1 YEAR/ Level-1-235C-UNLIM
MC33063AP	ACTIVE	PDIP	P	8	50	Pb-Free (RoHS)	CU NIPDAU	Level-NC-NC-NC
MC34063AD	ACTIVE	SOIC	D	8	75	Pb-Free (RoHS)	CU NIPDAU	Level-2-260C-1 YEAR/ Level-1-235C-UNLIM
MC34063ADR	ACTIVE	SOIC	D	8	2500	Pb-Free (RoHS)	CU NIPDAU	Level-2-260C-1 YEAR/ Level-1-235C-UNLIM
MC34063AP	ACTIVE	PDIP	P	8	50	Pb-Free (RoHS)	CU NIPDAU	Level-NC-NC-NC

⁽¹⁾ The marketing status values are defined as follows:

ACTIVE: Product device recommended for new designs.

LIFEBUY: TI has announced that the device will be discontinued, and a lifetime-buy period is in effect.

NRND: Not recommended for new designs. Device is in production to support existing customers, but TI does not recommend using this part in a new design.

PREVIEW: Device has been announced but is not in production. Samples may or may not be available.

OBSELETE: TI has discontinued the production of the device.

⁽²⁾ Eco Plan - May not be currently available - please check <http://www.ti.com/productcontent> for the latest availability information and additional product content details.

None: Not yet available Lead (Pb-Free).

Pb-Free (RoHS): TI's terms "Lead-Free" or "Pb-Free" mean semiconductor products that are compatible with the current RoHS requirements for all 6 substances, including the requirement that lead not exceed 0.1% by weight in homogeneous materials. Where designed to be soldered at high temperatures, TI Pb-Free products are suitable for use in specified lead-free processes.

Green (RoHS & no Sb/Br): TI defines "Green" to mean "Pb-Free" and in addition, uses package materials that do not contain halogens, including bromine (Br) or antimony (Sb) above 0.1% of total product weight.

⁽³⁾ MSL, Peak Temp. -- The Moisture Sensitivity Level rating according to the JEDEC industry standard classifications, and peak solder temperature.

Important Information and Disclaimer:The information provided on this page represents TI's knowledge and belief as of the date that it is provided. TI bases its knowledge and belief on information provided by third parties, and makes no representation or warranty as to the accuracy of such information. Efforts are underway to better integrate information from third parties. TI has taken and continues to take reasonable steps to provide representative and accurate information but may not have conducted destructive testing or chemical analysis on incoming materials and chemicals. TI and TI suppliers consider certain information to be proprietary, and thus CAS numbers and other limited information may not be available for release.

In no event shall TI's liability arising out of such information exceed the total purchase price of the TI part(s) at issue in this document sold by TI to Customer on an annual basis.

MECHANICAL DATA

MPDI001A – JANUARY 1995 – REVISED JUNE 1999

P (R-PDIP-T8)

PLASTIC DUAL-IN-LINE

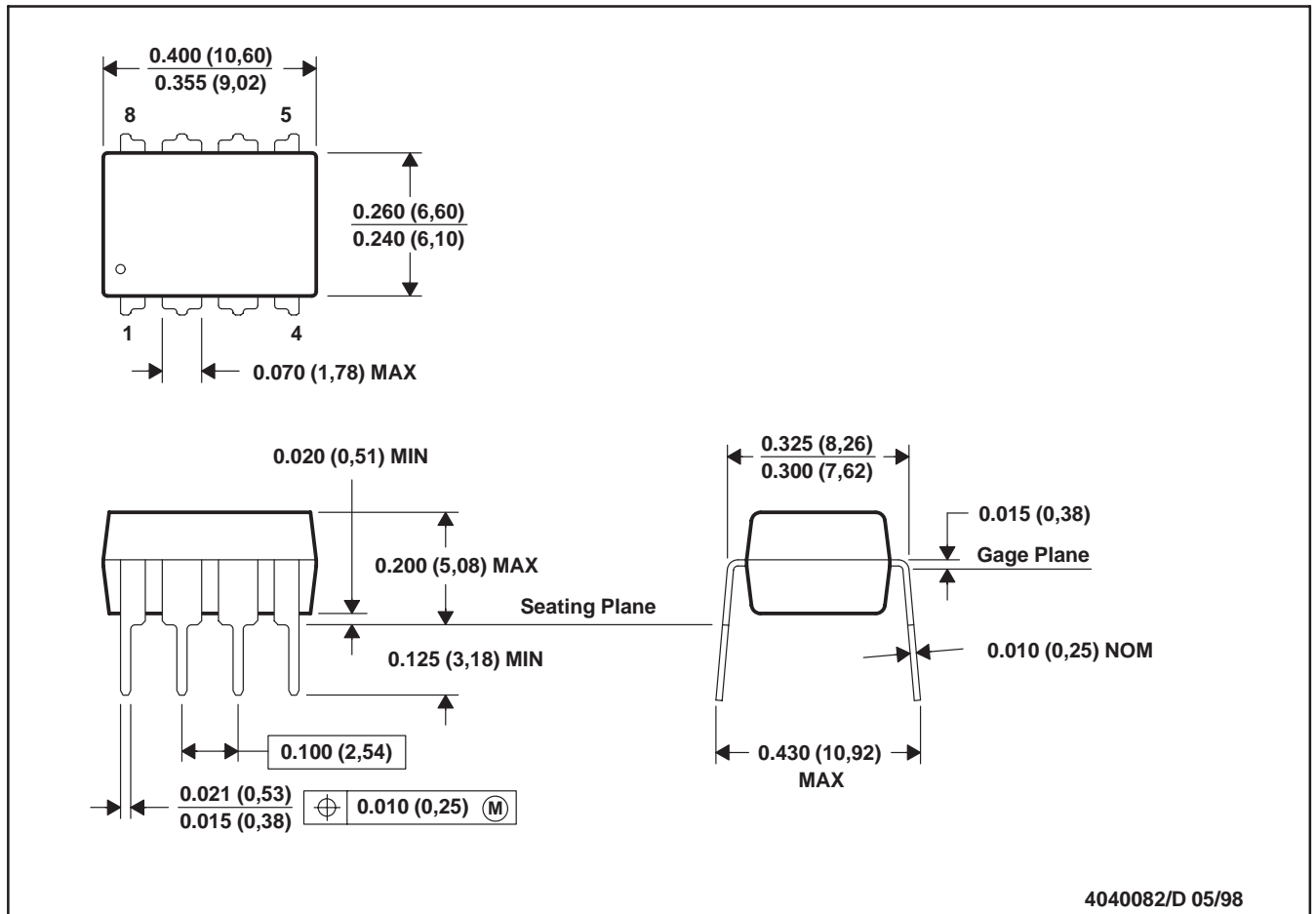

- NOTES: A. All linear dimensions are in inches (millimeters).
 B. This drawing is subject to change without notice.
 C. Falls within JEDEC MS-001

MECHANICAL DATA

D (R-PDSO-G8)

PLASTIC SMALL-OUTLINE PACKAGE

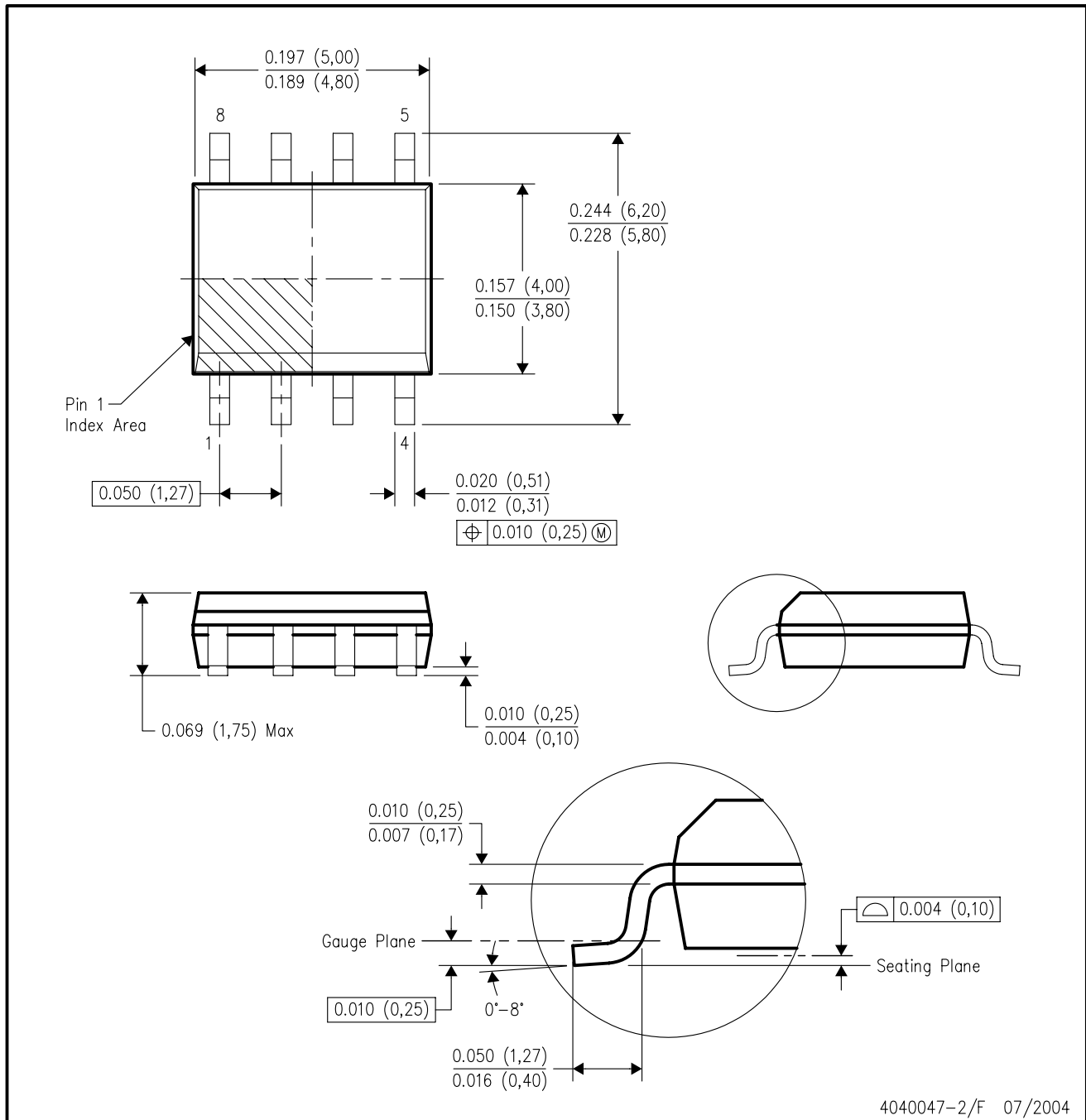

- NOTES:
- All linear dimensions are in inches (millimeters).
 - This drawing is subject to change without notice.
 - Body dimensions do not include mold flash or protrusion not to exceed 0.006 (0,15).
 - Falls within JEDEC MS-012 variation AA.

IMPORTANT NOTICE

Texas Instruments Incorporated and its subsidiaries (TI) reserve the right to make corrections, modifications, enhancements, improvements, and other changes to its products and services at any time and to discontinue any product or service without notice. Customers should obtain the latest relevant information before placing orders and should verify that such information is current and complete. All products are sold subject to TI's terms and conditions of sale supplied at the time of order acknowledgment.

TI warrants performance of its hardware products to the specifications applicable at the time of sale in accordance with TI's standard warranty. Testing and other quality control techniques are used to the extent TI deems necessary to support this warranty. Except where mandated by government requirements, testing of all parameters of each product is not necessarily performed.

TI assumes no liability for applications assistance or customer product design. Customers are responsible for their products and applications using TI components. To minimize the risks associated with customer products and applications, customers should provide adequate design and operating safeguards.

TI does not warrant or represent that any license, either express or implied, is granted under any TI patent right, copyright, mask work right, or other TI intellectual property right relating to any combination, machine, or process in which TI products or services are used. Information published by TI regarding third-party products or services does not constitute a license from TI to use such products or services or a warranty or endorsement thereof. Use of such information may require a license from a third party under the patents or other intellectual property of the third party, or a license from TI under the patents or other intellectual property of TI.

Reproduction of information in TI data books or data sheets is permissible only if reproduction is without alteration and is accompanied by all associated warranties, conditions, limitations, and notices. Reproduction of this information with alteration is an unfair and deceptive business practice. TI is not responsible or liable for such altered documentation.

Resale of TI products or services with statements different from or beyond the parameters stated by TI for that product or service voids all express and any implied warranties for the associated TI product or service and is an unfair and deceptive business practice. TI is not responsible or liable for any such statements.

Following are URLs where you can obtain information on other Texas Instruments products and application solutions:

Products		Applications	
Amplifiers	amplifier.ti.com	Audio	www.ti.com/audio
Data Converters	dataconverter.ti.com	Automotive	www.ti.com/automotive
DSP	dsp.ti.com	Broadband	www.ti.com/broadband
Interface	interface.ti.com	Digital Control	www.ti.com/digitalcontrol
Logic	logic.ti.com	Military	www.ti.com/military
Power Mgmt	power.ti.com	Optical Networking	www.ti.com/opticalnetwork
Microcontrollers	microcontroller.ti.com	Security	www.ti.com/security
		Telephony	www.ti.com/telephony
		Video & Imaging	www.ti.com/video
		Wireless	www.ti.com/wireless

Mailing Address: Texas Instruments
Post Office Box 655303 Dallas, Texas 75265