

SN54ALS193A, SN74ALS193A SYNCHRONOUS 4-BIT UP/DOWN BINARY COUNTERS WITH DUAL CLOCK AND CLEAR

SDAS211C – DECEMBER 1982 – REVISED JULY 1996

- Look-Ahead Circuitry Enhances Cascaded Counters
- Fully Synchronous in Count Modes
- Parallel Asynchronous Load for Modulo-N Count Lengths
- Asynchronous Clear
- Package Options Include Plastic Small-Outline (D) Packages, Ceramic Chip Carriers (FK), and Standard Plastic (N) and Ceramic (J) 300-mil DIPs

description

The 'ALS193A are synchronous, reversible, 4-bit up/down binary counters. Synchronous counting operation is provided by having all flip-flops clocked simultaneously so that the outputs change coincident with each other when instructed by the steering logic. This mode of operation eliminates the output counting spikes normally associated with asynchronous (ripple-clock) counters.

The outputs of the four flip-flops are triggered on a low-to-high-level transition of either count/clock (UP or DOWN) input. The direction of the count is determined by which count input is pulsed while the other count input is high.

All four counters are fully programmable; that is, each output may be preset to either level by placing a low on the load (\overline{LOAD}) input and entering the desired data at the data inputs. The output changes to agree with the data inputs independently of the count pulses. This feature allows the counters to be used as modulo-N dividers by simply modifying the count length with the preset inputs.

A high level applied to the clear (\overline{CLR}) input forces all outputs to the low level. The clear function is independent of the count and \overline{LOAD} inputs. The UP, DOWN, and \overline{LOAD} inputs are buffered to lower the drive requirement, which significantly reduces the loading on, or current required by, clock drivers, etc., for long parallel words.

These counters are designed to be cascaded without the need for external circuitry. The borrow (\overline{BO}) output produces a low-level pulse while the count is zero (all Q outputs low) and the DOWN input is low. Similarly, the carry (\overline{CO}) output produces a low-level pulse while the count is 9 or 15 (all Q outputs high) and the UP input is low. The counters can then be easily cascaded by feeding \overline{BO} and \overline{CO} to the count-down and count-up inputs, respectively, of the succeeding counter.

The SN54ALS193A is characterized for operation over the full military temperature range of -55°C to 125°C . The SN74ALS193A is characterized for operation from 0°C to 70°C .

SN54ALS193A . . . J PACKAGE
SN74ALS193A . . . D OR N PACKAGE
(TOP VIEW)

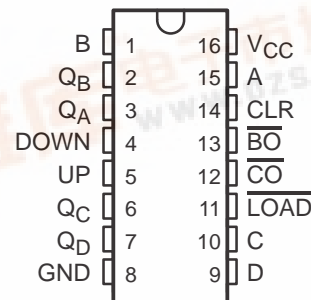

SN54ALS193A . . . FK PACKAGE
(TOP VIEW)

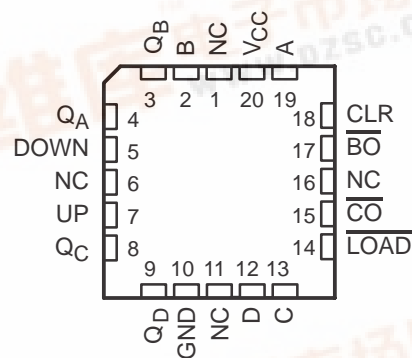

NC – No internal connection

Please be aware that an important notice concerning availability, standard warranty, and use in critical applications of Texas Instruments semiconductor products and disclaimers thereto appears at the end of this data sheet.

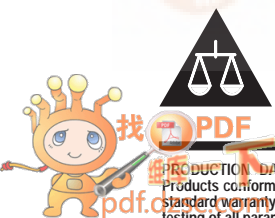

SN54ALS193A, SN74ALS193A SYNCHRONOUS 4-BIT UP/DOWN BINARY COUNTERS WITH DUAL CLOCK AND CLEAR

SDAS211C – DECEMBER 1982 – REVISED JULY 1996

logic symbol†

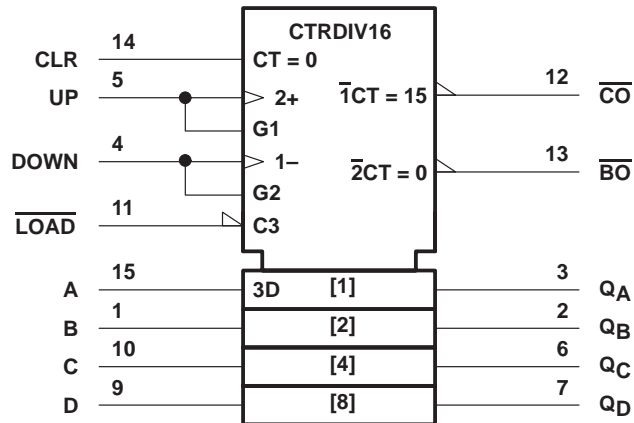

† This symbol is in accordance with ANSI/IEEE Std 91-1984 and IEC Publication 617-12.
Pin numbers shown are for the D, J, and N packages.

SN54ALS193A, SN74ALS193A
SYNCHRONOUS 4-BIT UP/DOWN BINARY COUNTERS
WITH DUAL CLOCK AND CLEAR
SDAS211C – DECEMBER 1982 – REVISED JULY 1996

logic diagram (positive logic)

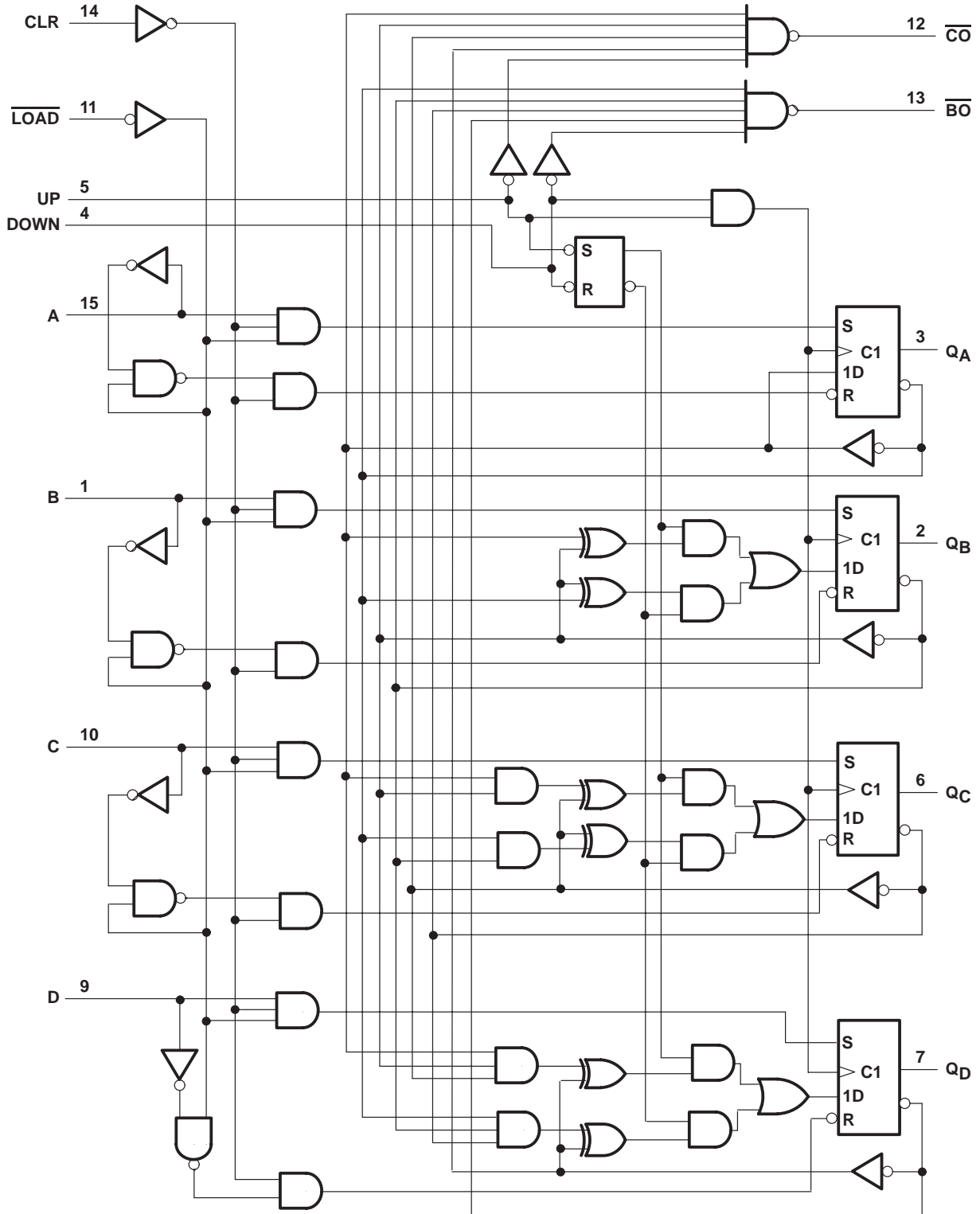

Pin numbers shown are for the D, J, and N packages.

SN54ALS193A, SN74ALS193A SYNCHRONOUS 4-BIT UP/DOWN BINARY COUNTERS WITH DUAL CLOCK AND CLEAR

SDAS211C – DECEMBER 1982 – REVISED JULY 1996

typical clear, load, and count sequence

the following sequence is illustrated below:

1. Clear outputs to zero
2. Load (preset) to binary 13
3. Count up to 14, 15 (carry), 0, 1, and 2
4. Count down to 1, 0 (borrow), 15, 14, and 13

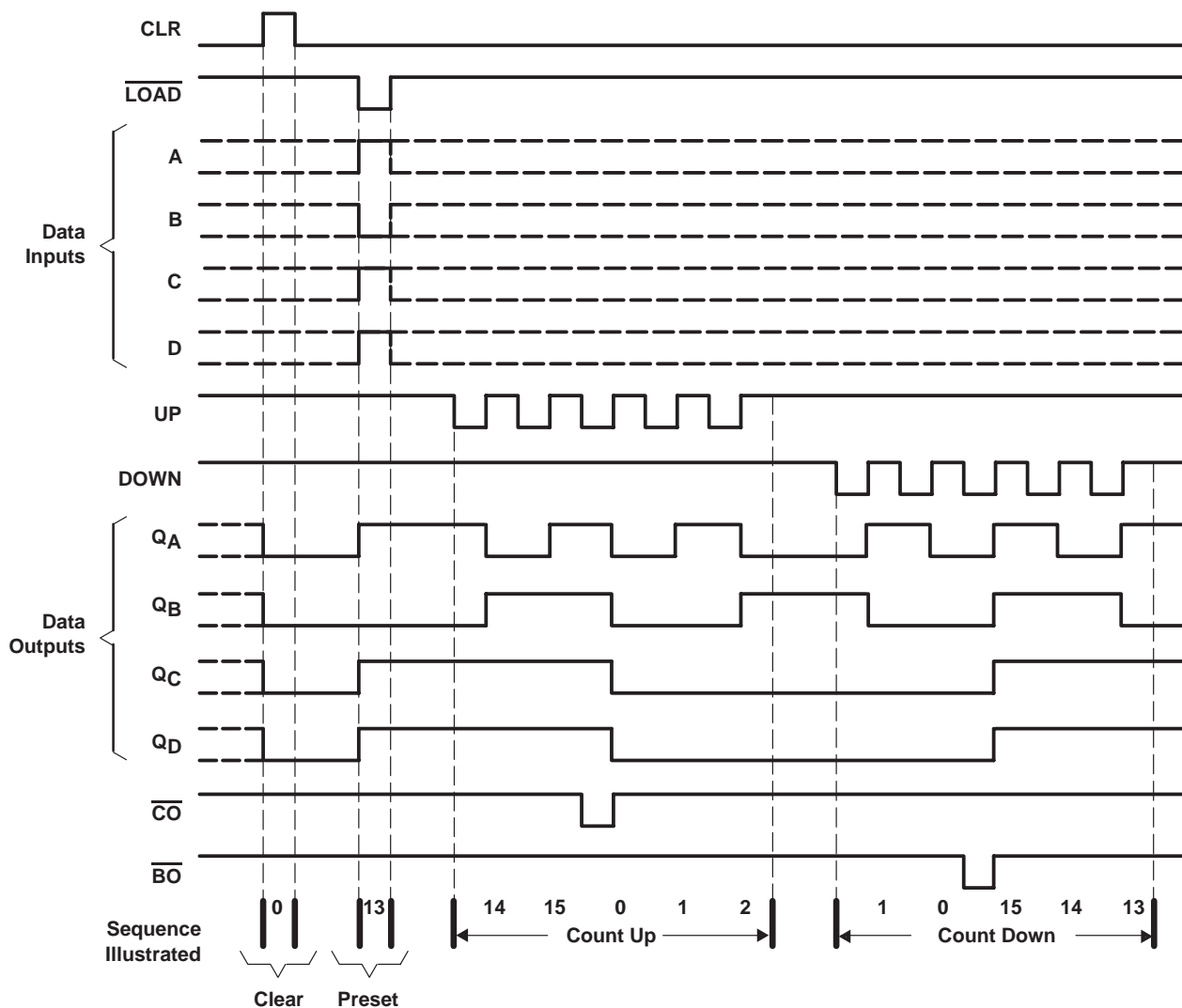

NOTES: A. Clear overrides load, data, and count inputs.
B. When counting up, count-down input must be high; when counting down, count-up input must be high.

SN54ALS193A, SN74ALS193A
SYNCHRONOUS 4-BIT UP/DOWN BINARY COUNTERS
WITH DUAL CLOCK AND CLEAR
SDAS211C – DECEMBER 1982 – REVISED JULY 1996

absolute maximum ratings over operating free-air temperature range (unless otherwise noted)†

Supply voltage, V_{CC}	7 V
Input voltage, V_I	7 V
Operating free-air temperature range, T_A : SN54ALS193A	–55°C to 125°C
SN74ALS193A	0°C to 70°C
Storage temperature range, T_{stg}	–65°C to 150°C

† Stresses beyond those listed under “absolute maximum ratings” may cause permanent damage to the device. These are stress ratings only, and functional operation of the device at these or any other conditions beyond those indicated under “recommended operating conditions” is not implied. Exposure to absolute-maximum-rated conditions for extended periods may affect device reliability.

recommended operating conditions

		SN54ALS193A			SN74ALS193A			UNIT
		MIN	NOM	MAX	MIN	NOM	MAX	
V_{CC}	Supply voltage	4.5	5	5.5	4.5	5	5.5	V
V_{IH}	High-level input voltage	2			2			V
V_{IL}	Low-level input voltage			0.7			0.8	V
I_{OH}	High-level output current			–0.4			–0.4	mA
I_{OL}	Low-level output current			4			8	mA
f_{clock}	Clock frequency	0		20	0		30	MHz
t_w	Pulse duration	CLR high		10	10		ns	
		LOAD low		25	20			
		UP or DOWN high or low		30	16.5			
t_{su}	Setup time	Data before $\overline{LOAD}\uparrow$		25	20		ns	
		CLR inactive before UP or DOWN		20	20			
		LOAD inactive before UP or DOWN		20	20			
t_h	Hold time	Data after $\overline{LOAD}\uparrow$		5	5		ns	
		UP high after $\overline{DOWN}\uparrow$		5	0			
		DOWN high after $\overline{UP}\uparrow$		5	0			
T_A	Operating free-air temperature	–55		125	0		70	°C

electrical characteristics over recommended operating free-air temperature range (unless otherwise noted)

PARAMETER		TEST CONDITIONS		SN54ALS193A		SN74ALS193A		UNIT	
				MIN	TYP‡	MAX	MIN		TYP‡
V_{IK}		$V_{CC} = 4.5\text{ V}$,	$I_I = -18\text{ mA}$		–1.5		–1.5	V	
V_{OH}		$V_{CC} = 4.5\text{ V to }5.5\text{ V}$,	$I_{OH} = -0.4\text{ mA}$	$V_{CC} - 2$		$V_{CC} - 2$		V	
V_{OL}		$V_{CC} = 4.5\text{ V}$	$I_{OL} = 4\text{ mA}$	0.25	0.4	0.25	0.4	V	
			$I_{OL} = 8\text{ mA}$			0.35	0.5		
I_I		$V_{CC} = 5.5\text{ V}$,	$V_I = 7\text{ V}$		0.1		0.35	0.1	mA
I_{IH}		$V_{CC} = 5.5\text{ V}$,	$V_I = 2.7\text{ V}$		20		20	μA	
I_{IL}	UP or DOWN	$V_{CC} = 5.5\text{ V}$,	$V_I = 0.4\text{ V}$		–0.2		–0.2	mA	
	All others				–0.1		–0.1		
$I_{O\S}$		$V_{CC} = 5.5\text{ V}$,	$V_O = 2.25\text{ V}$	–20	–112	–30	–112	mA	
I_{CC}		$V_{CC} = 5.5\text{ V}$,	See Note 1	12	22	12	22	mA	

‡ All typical values are at $V_{CC} = 5\text{ V}$, $T_A = 25^\circ\text{C}$.

§ The output conditions have been chosen to produce a current that closely approximates one half of the true short-circuit output current, I_{OS} .

NOTE 1: I_{CC} is measured with the clear and load inputs grounded and all other inputs at 4.5 V.

SN54ALS193A, SN74ALS193A
SYNCHRONOUS 4-BIT UP/DOWN BINARY COUNTERS
WITH DUAL CLOCK AND CLEAR

SDAS211C – DECEMBER 1982 – REVISED JULY 1996

switching characteristics (see Figure 1)

PARAMETER	FROM (INPUT)	TO (OUTPUT)	V _{CC} = 4.5 V to 5.5 V, C _L = 50 pF, R ₁ = R ₂ = 500 Ω, T _A = MIN to MAX†				UNIT
			SN54ALS193A		SN74ALS193A		
			MIN	MAX	MIN	MAX	
f _{max}			25		30	MHz	
t _{PLH}	UP	\overline{CO}	3	20	3	16	ns
t _{PHL}			3	21	5	18	
t _{PLH}	DOWN	\overline{BO}	4	20	4	16	ns
t _{PHL}			5	22	5	18	
t _{PLH}	UP or DOWN	Any Q	3	27	3	19	ns
t _{PHL}			4	23	4	17	
t _{PLH}	\overline{LOAD}	Any Q	7	38	7	30	ns
t _{PHL}			8	37	8	28	
t _{PHL}	CLR	Any Q	5	20	5	17	ns

† For conditions shown MIN or MAX, use the appropriate value specified under recommended operating conditions.

SN54ALS193A, SN74ALS193A
**SYNCHRONOUS 4-BIT UP/DOWN BINARY COUNTERS
 WITH DUAL CLOCK AND CLEAR**
 SDAS211C – DECEMBER 1982 – REVISED JULY 1996

**PARAMETER MEASUREMENT INFORMATION
 SERIES 54ALS/74ALS AND 54AS/74AS DEVICES**

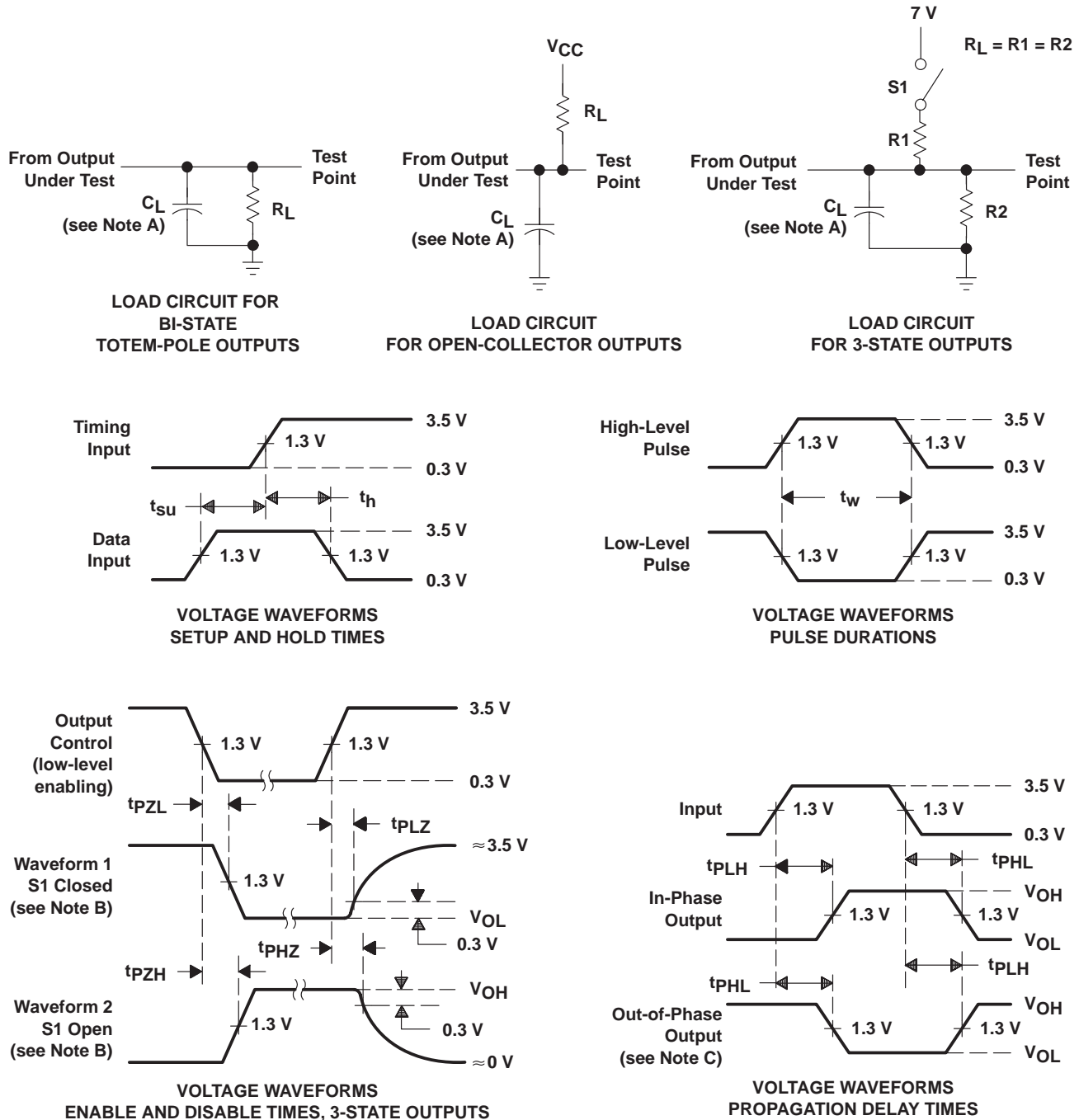

- NOTES: A. C_L includes probe and jig capacitance.
 B. Waveform 1 is for an output with internal conditions such that the output is low except when disabled by the output control. Waveform 2 is for an output with internal conditions such that the output is high except when disabled by the output control.
 C. When measuring propagation delay items of 3-state outputs, switch S1 is open.
 D. All input pulses have the following characteristics: $PRR \leq 1$ MHz, $t_r = t_f = 2$ ns, duty cycle = 50%.
 E. The outputs are measured one at a time with one transition per measurement.

Figure 1. Load Circuits and Voltage Waveforms

IMPORTANT NOTICE

Texas Instruments and its subsidiaries (TI) reserve the right to make changes to their products or to discontinue any product or service without notice, and advise customers to obtain the latest version of relevant information to verify, before placing orders, that information being relied on is current and complete. All products are sold subject to the terms and conditions of sale supplied at the time of order acknowledgement, including those pertaining to warranty, patent infringement, and limitation of liability.

TI warrants performance of its semiconductor products to the specifications applicable at the time of sale in accordance with TI's standard warranty. Testing and other quality control techniques are utilized to the extent TI deems necessary to support this warranty. Specific testing of all parameters of each device is not necessarily performed, except those mandated by government requirements.

CERTAIN APPLICATIONS USING SEMICONDUCTOR PRODUCTS MAY INVOLVE POTENTIAL RISKS OF DEATH, PERSONAL INJURY, OR SEVERE PROPERTY OR ENVIRONMENTAL DAMAGE ("CRITICAL APPLICATIONS"). TI SEMICONDUCTOR PRODUCTS ARE NOT DESIGNED, AUTHORIZED, OR WARRANTED TO BE SUITABLE FOR USE IN LIFE-SUPPORT DEVICES OR SYSTEMS OR OTHER CRITICAL APPLICATIONS. INCLUSION OF TI PRODUCTS IN SUCH APPLICATIONS IS UNDERSTOOD TO BE FULLY AT THE CUSTOMER'S RISK.

In order to minimize risks associated with the customer's applications, adequate design and operating safeguards must be provided by the customer to minimize inherent or procedural hazards.

TI assumes no liability for applications assistance or customer product design. TI does not warrant or represent that any license, either express or implied, is granted under any patent right, copyright, mask work right, or other intellectual property right of TI covering or relating to any combination, machine, or process in which such semiconductor products or services might be or are used. TI's publication of information regarding any third party's products or services does not constitute TI's approval, warranty or endorsement thereof.