



5-Bit Programmable Dual Power Supply Controller for Pentium® II Processor

ADP3153

FEATURES

- 5-Bit Digitally Programmable 1.8 V to 3.5 V Output Voltage
- Dual N-Channel Synchronous Driver
- Total Output Accuracy $\pm 1\%$ (0°C to +70°C)
- High Efficiency
- Current-Mode Operation
- Short Circuit Protection
- Power Good Output
- Overvoltage Protection Crowbar
- On-Board Linear Regulator Controller
- VRM 8.2 Compatible
- Narrow Body TSSOP 20-Lead Package

APPLICATIONS

- Desktop PC Power Supply for:
- Pentium II Processor
 - Deschutes Processor
 - Pentium Pro Processor
 - Pentium Processor
 - AMD-K6 Processor
 - VRM Modules

GENERAL DESCRIPTION

The ADP3153 is a highly efficient synchronous switching regulator controller and a linear regulator controller. The switching regulator controller is optimized for Pentium II and Deschutes Processor applications where 5 V is stepped down to a digitally controlled output voltage between 1.8 V and 3.5 V. Using a 5-bit DAC to read a voltage identification (VID) code directly from the processor, the ADP3153 uses a current mode constant off-time architecture to generate its precise output voltage.

The ADP3153 drives two N-channel MOSFETS in a synchronous rectified buck converter, at a maximum switching frequency of 250 kHz. Using the recommended loop compensation and guidelines, the ADP3153 provides a dc/dc converter that meets Intel's stringent transient specifications with a minimum number of output capacitors and smallest footprint. Additionally, the current mode architecture also provides guaranteed short circuit protection and adjustable current limiting.

The ADP3153's linear regulator controller drives an external N-channel device. The output voltage is set by the ratio of the external feedback resistors. The controller has been designed for excellent load transient response.

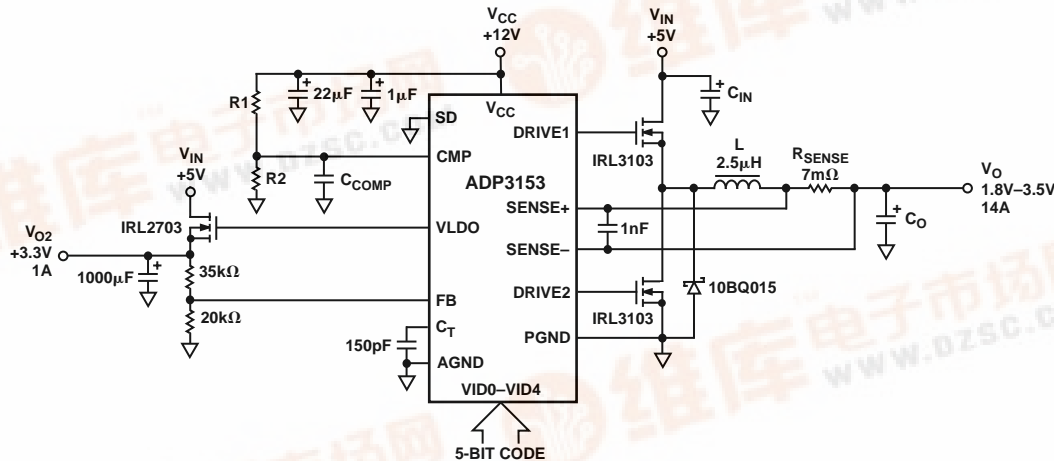

Figure 1. Typical Application

Pentium is a registered trademark of Intel Corporation.
All other trademarks are the property of their respective holders.

REV. 0

Information furnished by Analog Devices is believed to be accurate and reliable. However, no responsibility is assumed by Analog Devices for its use, nor for any infringements of patents or other rights of third parties which may result from its use. No license is granted by implication or otherwise under any patent or patent rights of Analog Devices.

ADP3153—SPECIFICATIONS (0°C ≤ T_A ≤ +70°C, V_{CC} = 12 V, V_{IN} = 5 V, unless otherwise noted)

Parameter	Symbol	Conditions	Min	Typ	Max	Units
OUTPUT ACCURACY 1.8 V Output Voltage 2.8 V Output Voltage 3.5 V Output Voltage	V _O	With Respect to Nominal Output Voltage (Figure 1)	-1.0 -1.0 -1.0		1.0 1.0 1.0	% % %
OUTPUT VOLTAGE LINE REGULATION	ΔV _O	I _{LOAD} = 10 A (Figure 2) V _{IN} = 4.75 V to 5.25 V		0.05		%
OUTPUT VOLTAGE LOAD REGULATION	ΔV _O	(Figure 2) 200 mA < I _{LOAD} < 14 A		0.1		%
INPUT DC SUPPLY CURRENT ¹ Normal Mode Shutdown	I _Q	V _{SD} = 0.8 V T _A = +25°C, V _{SD} = 2.0 V		4.1 140	5.5 250	mA μA
CURRENT SENSE THRESHOLD VOLTAGE	V ₁₁ -V ₁₀	V ₁₀ Forced to V _{OUT} - 3%	125	145	165	mV
VID PINS THRESHOLD Low High	V ₂₀ , V ₁ -V ₄		2.0		0.6	V V
VID PINS INPUT CURRENT	I ₂₀ , I ₁ -I ₄	VID = 0 V		110	220	μA
VID0-VID4 PULL-UP RESISTANCE	R _{VID}		20	30		kΩ
C _T PIN DISCHARGE CURRENT	I ₁₂	T _A = +25°C V _{OUT} in Regulation V _{OUT} = 0 V		65 2	10	μA μA
OFFTIME	t _{OFF}	C _T = 150 pF	1.8	2.45	3.2	μs
DRIVER OUTPUT TRANSITION TIMES	t _R , t _F	C _L = 7000 pF (Pins 16, 17) T _A = +25°C		120	200	ns
POSITIVE POWER GOOD TRIP POINT	V _{PWRGD}	% Above Output Voltage		5	8	%
NEGATIVE POWER GOOD TRIP POINT	V _{PWRGD}	% Below Output Voltage	-8	-5		%
POWER GOOD RESPONSE TIME	t _{PWRGD}			500		μs
CROWBAR TRIP POINT	V _{CROWBAR}	% Above Output Voltage	9	15	24	%
ERROR AMPLIFIER OUTPUT IMPEDANCE	R _{OERR}			145		kΩ
ERROR AMPLIFIER TRANSCONDUCTANCE	G _{MERR}			2.2		mmho
ERROR AMPLIFIER MINIMUM OUTPUT VOLTAGE	V _{CMPMIN}	V ₁₀ Forced to V _{OUT} + 3%		0.8		V
ERROR AMPLIFIER MAXIMUM OUTPUT VOLTAGE	V _{CMPMAX}	V ₁₀ Forced to V _{OUT} - 3%		2.4		V
ERROR AMPLIFIER BANDWIDTH -3 dB	BW _{ERR}	CMP = Open		500		kHz
LINEAR REGULATOR FEEDBACK CURRENT	I _{FB}			0.35	1	μA
LINEAR REGULATOR OUTPUT VOLTAGE ²	V _{O2}	Figure 2 R _{PROG} = 35K, R ₃ = 20K, I _{O2} = 1 A	3.24	3.30	3.38	V
SHUTDOWN (SD) PIN Low Threshold High Threshold Input Current	SD _L SD _H SD _{IB}	Part Active Part in Shutdown	2.0		0.6	V V μA

NOTES

¹Dynamic supply current is higher due to the gate charge being delivered to the external MOSFETS.

²The LDO is tested in a V_{OUT} = 3.3 V configuration with the circuit shown in Figure 2. By selecting a different R_{PROG} value, any output voltage above 1.20 V can be set.

All limits at temperature extremes are guaranteed via correlation using standard quality control methods. Specifications are subject to change without notice.

PIN FUNCTION DESCRIPTIONS

Pin	Mnemonic	Function
1–4, 20	VID1–VID4, VID0	Voltage Identification DAC Input Pins. These pins are internally pulled up to V_{REG} providing a logic high if left open. The DAC output range is 600 mV to 1.167 V. Leaving all five DAC inputs open results in placing the ADP3153 into shutdown.
5	AGND	Analog Ground Pin. This pin must be routed separately to the (–) terminal of C_{OUT} .
6	SD	Shutdown Pin. A logic high will place the ADP3153 in shutdown and disable both outputs. This pin is internally pulled down.
7	FB	This pin is the feedback connection for the linear controller. Connect this pin to the resistor divider network to set the output voltage of the linear regulator.
8, 18	NC	No Connect.
9	VLDO	Gate Drive for the Linear Regulator N-channel MOSFET.
10	SENSE–	Connects to the internal resistor divider which along with the VID code, sets the output voltage. Pin 10 is also the (–) input for the current comparator.
11	SENSE+	The (+) input for the current comparator. A threshold between Pins 10 and 11 set by the error amplifier in conjunction with R_{SENSE} , sets the current trip point.
12	C_T	External Capacitor C_T from Pin 12 to ground sets the off time of the device.
13	CMP	Error Amplifier Compensation Point. The current comparator threshold increases with the Pin 13 voltage.
14	PWRGD	Power Good Pin. An open drain signal to indicate that the output voltage is within a $\pm 5\%$ regulation band.
15	V_{CC}	Input Voltage Pin.
16	DRIVE2	Gate Drive for the Synchronous Rectifier N-channel MOSFET. The voltage at Pin 16 swings from ground to V_{CC} .
17	DRIVE1	Gate Drive for the buck switch N-channel MOSFET. The voltage at Pin 17 swings from ground to V_{CC} .
19	PGND	Driver Power Ground. Connects to the source of the bottom N-channel MOSFET onto the (–) terminal of C_{IN} .

ABSOLUTE MAXIMUM RATINGS*

Input Supply Voltage (Pin 15)	–0.3 V to +16 V
Shutdown Input Voltage	–0.3 V to +16 V
Power Dissipation	Internally Limited
Operating Temperature Range	0°C to +70°C
Junction Temperature	150°C
θ_{JA}	110°C/W
Storage Temperature Range	–65°C to +150°C
Lead Temperature Range (Soldering 10 sec)	+300°C

*This is a stress rating only; operation beyond these limits can cause the device to be permanently damaged.

ORDERING GUIDE

Model	Temperature Range	Package Description	Package Option
ADP3153ARU	0°C to +70°C	Thin Shrink Small Outline (TSSOP)	RU-20

PIN CONFIGURATION

20-Lead Thin Shrink Small Outline (TSSOP) (RU-20)

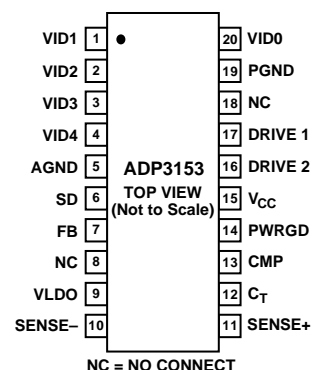

CAUTION

ESD (electrostatic discharge) sensitive device. Electrostatic charges as high as 4000 V readily accumulate on the human body and test equipment and can discharge without detection. Although the ADP3153 features proprietary ESD protection circuitry, permanent damage may occur on devices subjected to high energy electrostatic discharges. Therefore, proper ESD precautions are recommended to avoid performance degradation or loss of functionality.



ADP3153

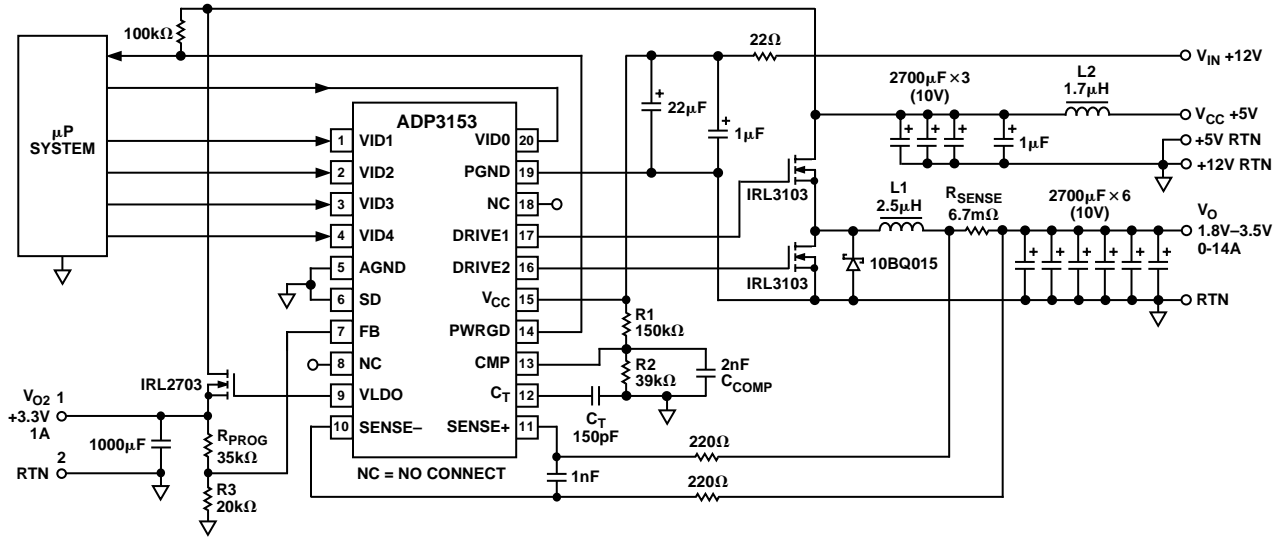

Figure 2. Typical VRM8.2 Compliant Core DC/DC Converter Circuit

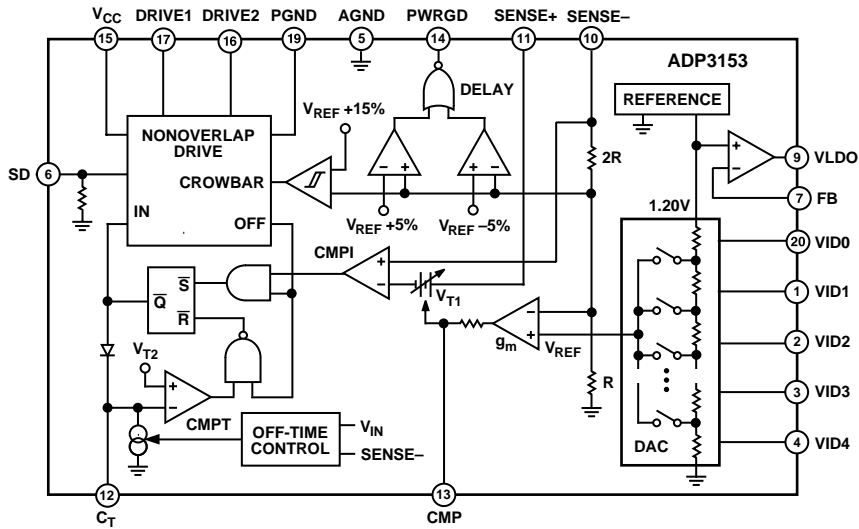

Figure 3. Functional Block Diagram

Typical Performance Characteristics—ADP3153

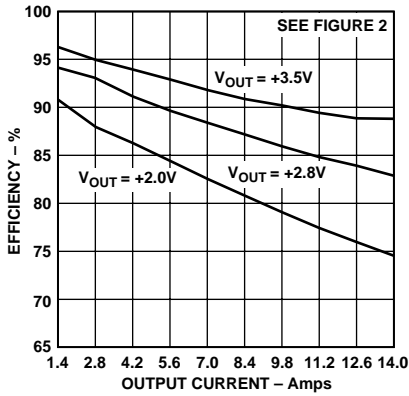

Figure 4. Efficiency vs. Output Current

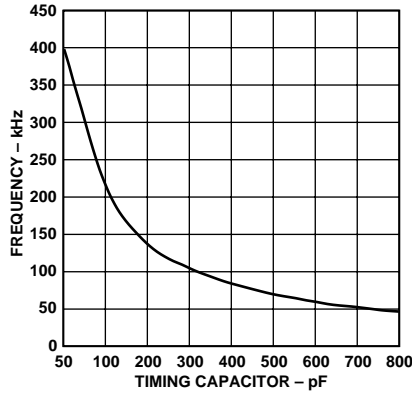

Figure 5. Frequency vs. Timing Capacitor

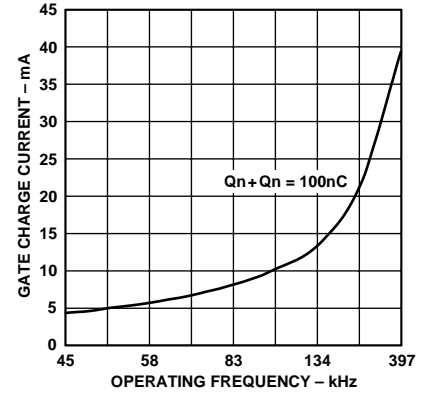

Figure 6. Gate Charge vs. Supply Current

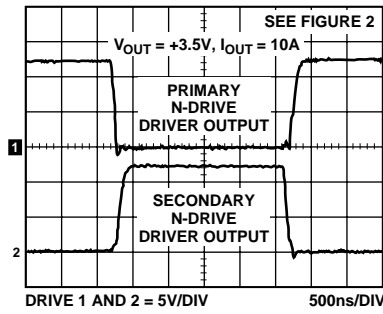

Figure 7. Gate Switching Waveforms

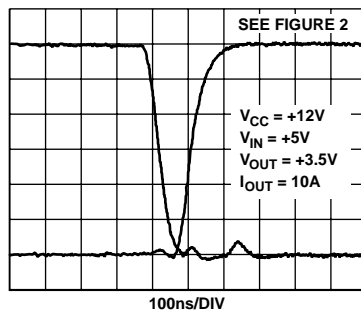

Figure 8. Driver Transition Waveforms

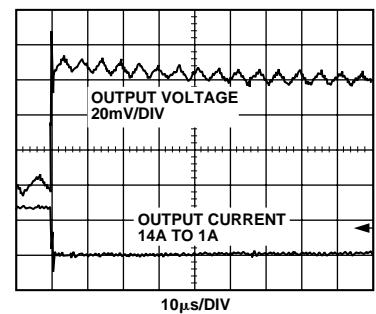

Figure 9. Transient Response, 14 A–1A of Figure 2 Circuit

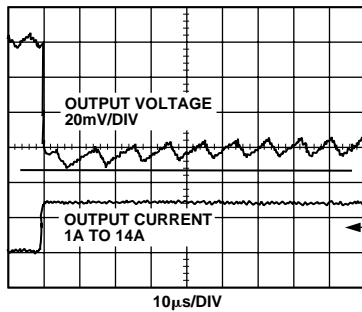

Figure 10. Transient Response, 1A–14 A of Figure 2 Circuit

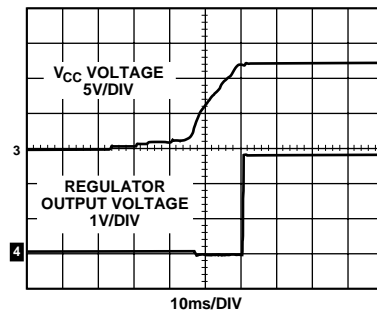

Figure 11. Power-On Start-Up Waveforms

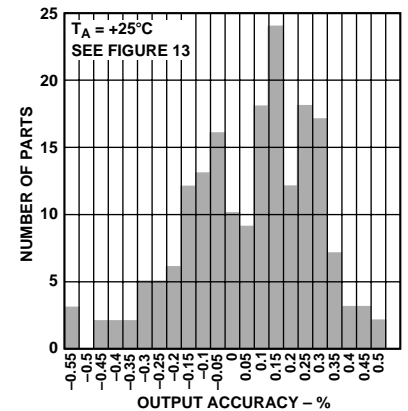

Figure 12. Output Accuracy Distribution

ADP3153

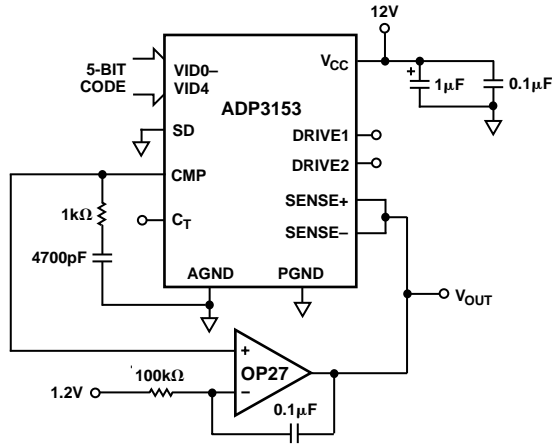

Figure 13. Closed-Loop Test Circuit for Accuracy

APPLICATION INFORMATION

The ADP3153 uses a current-mode, constant-off-time control technique to switch a pair of external N-channel MOSFETs in a synchronous rectified buck converter application. Due to the constant-off-time operation, no slope compensation is needed. A unique feature of the constant-off-time control technique is that the converter's frequency becomes a function of the ratio of input voltage to output voltage. The off time is determined by the value of the external capacitor connected to the C_T pin. The on time varies in such a way that a regulated output voltage is maintained.

The output voltage is sensed by an internal voltage divider that is connected to the SENSE- pin. A voltage-error amplifier g_m compares the values of the divided output voltage with a reference voltage. The reference voltage is set by an on-board 5-bit DAC, which reads the code present at the voltage identification (VID) pins and converts it to a precise value between 600 mV and 1.167 V. Refer to Table I for the output voltage vs. VID pin code information.

During continuous-inductor-current mode of operation, the voltage-error amplifier g_m and the current comparator CMPI are the main control elements. During the on time of the high side MOSFET, the current comparator CMPI monitors the voltage between the SENSE+ and SENSE- pins. When the voltage level between the two pins reaches the threshold level V_{T1} , the high side drive output is switched to zero, which turns off the high side MOSFET. The timing capacitor C_T is now discharged at a rate determined by the off time controller. In order to maintain a ripple current in the inductor, which is independent of the output voltage, the discharge current is made proportional to the value of the output voltage (measured at the SENSE- pin). While the timing capacitor is discharging, the low side drive output goes high, turning on the low side MOSFET. When the voltage level on the timing capacitor has discharged to the threshold voltage level V_{T2} , comparator CMPT resets the SR flip-flop. The output of the flip-flop forces the low side drive output to go low and the high side drive output to go high. As a result, the low side switch is turned off and the high side switch is turned on. The sequence is then repeated. As the load current increases, the output voltage starts to decrease. This causes an increase in the output of the voltage-error amplifier, which, in turn, leads to an increase in the current comparator threshold V_{T1} , thus tracking the load current.

Table I. Output Voltage vs. VID Code

VID4	VID3	VID2	VID1	VID0	VOUT
0	1	1	1	1	1.80
0	1	1	1	0	1.80
0	1	1	0	1	1.80
0	1	1	0	0	1.80
0	1	0	1	1	1.80
0	1	0	1	0	1.80
0	1	0	0	1	1.80
0	1	0	0	0	1.80
0	0	1	1	1	1.80
0	0	1	1	0	1.80
0	0	1	0	1	1.80
0	0	1	0	0	1.85
0	0	0	1	1	1.90
0	0	0	1	0	1.95
0	0	0	0	1	2.00
0	0	0	0	0	2.05
1	1	1	1	1	Shutdown
1	1	1	1	0	2.10
1	1	1	0	1	2.20
1	1	1	0	0	2.30
1	1	0	1	1	2.40
1	1	0	1	0	2.50
1	1	0	0	1	2.60
1	1	0	0	0	2.70
1	0	1	1	1	2.80
1	0	1	1	0	2.90
1	0	1	0	1	3.00
1	0	1	0	0	3.10
1	0	0	1	1	3.20
1	0	0	1	0	3.30
1	0	0	0	1	3.40
1	0	0	0	0	3.50

To prevent cross conduction of the external MOSFETs, feedback is incorporated to sense the state of the driver output pins. Before the low side drive output can go high, the high side drive output must be low. Likewise, the high side drive output is unable to go high while the low side drive output is high.

Power Good

The ADP3153 has an internal monitor which monitors the output voltage and drives the PWRGD pin of the device. This pin is an open drain output whose high level (when connected to a pull-up resistor) indicates that the output voltage has been within a $\pm 5\%$ regulation band of the targeted value for more than 500 μ s. The PWRGD pin will go low if the output is outside the regulation band for more than 500 μ s.

Output Crowbar

An added feature of using an N-channel MOSFET as the synchronous switch is the ability to crowbar the output with the same MOSFET. If the output voltage is 15% greater than the desired regulated value, the ADP3153 will turn on the lower MOSFET, which will current-limit the source power supply or blow its fuse, pull down the output voltage, and thus save the expensive microprocessor from destruction. The crowbar function releases at approximately 50% of the nominal output voltage. For example, if the output is programmed to 2.0 V, but is pulled up to 2.3 V or above, the crowbar will turn on the lower MOSFET. If in this case the output is pulled down to less than

1.0 V, the crowbar will release, allowing the output voltage to recover to 2.0 V.

Shutdown

The ADP3153 has a shutdown pin which is pulled logic low by an internal resistor. In this condition the device functions normally. This pin should be pulled high externally to disable the output drives.

Calculation of Component Values

The design parameters for a typical 300 MHz Pentium II application (Figure 2) are as follows:

- Input voltage: $V_{IN} = 5\text{ V}$
- Auxiliary input: $V_{CC} = 12\text{ V}$
- Output voltage: $V_O = 2.8\text{ V}$

Maximum output current:

$$I_{OMAX} = 14.2\text{ Adc}$$

Minimum output current:

$$I_{OMIN} = 0.8\text{ Adc}$$

Static tolerance of the supply voltage for the processor core:

$$\begin{aligned} \Delta V_{OST+} &= 100\text{ mV} \\ \Delta V_{OST-} &= -60\text{ mV} \end{aligned}$$

Transient tolerance (for less than 2 μs) of the supply voltage for the processor core when the load changes between the minimum and maximum values with a di/dt of 30 A/ μs :

$$\begin{aligned} \Delta V_{OTR+} &= 130\text{ mV} \\ \Delta V_{OTR-} &= -130\text{ mV} \end{aligned}$$

Input current di/dt when the load changes between the minimum and maximum values: less than 0.1 A/ μs

The above requirements correspond to Intel's published power supply requirements based on VRM 8.2 guidelines.

C_T Selection for Operating Frequency

The ADP3153 uses a constant-off-time architecture with t_{OFF} determined by an external timing capacitor C_T . Each time the high side N-channel MOSFET switch turns on, the voltage across C_T is reset to approximately 3.3 V. During the off time, C_T is discharged by a constant current of 65 μA to 2.3 V, that is by 1 V. The value of the off time is calculated from the preferred continuous-mode operating frequency. Assuming a nominal operating frequency of $f_{NOM} = 200\text{ kHz}$ at an output voltage of $V_O = 2.8\text{ V}$, the corresponding off time is:

$$t_{OFF} = \left(1 - \frac{V_O}{V_{IN}}\right) \frac{1}{f_{NOM}} = 2.2\ \mu\text{s}$$

The timing capacitor can be calculated from the equation:

$$C_T = \frac{t_{OFF} \times 65\ \mu\text{A}}{1\text{ V}} = 143\ \text{pF}$$

The converter operates at the nominal operating frequency only at the above specified V_O and at light load. At higher V_O , and

heavy load, the operating frequency decreases due to the parasitic voltage drops across the power devices. The actual minimum frequency at $V_O = 2.8\text{ V}$ is calculated to be 160 kHz (see Equation 1 below), where:

I_{IN}	is the input dc current (assuming an efficiency of 90%, $I_{IN} = 9\text{ A}$)
R_{IN}	is the resistance of the input filter (estimated value: 7 m Ω)
$R_{DS(ON)HSF}$	is the resistance of the high side MOSFET (estimated value: 10 m Ω)
$R_{DS(ON)LSF}$	is the resistance of the low side MOSFET (estimated value: 10 m Ω)
R_{SENSE}	is the resistance of the sense resistor (estimated value: 7 m Ω)
R_L	is the resistance of the inductor (estimated value: 6 m Ω)

C_O Selection—Determining the ESR

The selection of the output capacitor is driven by the required ESR and capacitance C_O . The ESR must be small enough that both the resistive voltage deviation due to a step change in the load current and the output ripple voltage stay below the values defined in the specification of the supplied microprocessor. The capacitance, C_O , must be large enough that the output is held up while the inductor current ramps up or down to the value corresponding to the new load current.

The total static tolerance of the Pentium II processor is 160 mV. Taking into account the $\pm 1\%$ setpoint accuracy of the ADP3153, and assuming a 0.5% (or 14 mV) peak-to-peak ripple, the allowed static voltage deviation of the output voltage when the load changes between the minimum and maximum values is 0.08 V. Assuming a step change of $\Delta I = I_{OMAX} - I_{OMIN} = 13.4\text{ A}$, and allocating all of the total allowed static deviation to the contribution of the ESR sets the following limit:

$$R_{E(MAX)} = ESR_{MAX1} = \frac{0.08}{13.4} = 5.9\ \text{m}\Omega$$

The output filter capacitor must have an ESR of less than 5.9 m Ω . One can use, for example, six FA type capacitors from Panasonic, with 2700 μF capacitance, 10 V voltage rating, and 34 m Ω ESR. The six capacitors have a total typical ESR of $\sim 5\text{ m}\Omega$ when connected in parallel.

Inductor Selection

The minimum inductor value can be calculated from ESR, off time, dc output voltage and allowed peak-to-peak ripple voltage.

$$L_{MIN1} = \frac{V_O t_{OFF} R_{E(MAX)}}{V_{RIPPLE, p-p}} = \frac{2.8 \times 2.2\ \mu \times 5.9\ \text{m}}{14\ \text{m}} = 2.6\ \mu\text{H}$$

The minimum inductance gives a peak-to-peak ripple current of 2.15 A, or 15% of the maximum dc output current I_{OMAX} .

$$f_{MIN} = \frac{1}{t_{OFF}} \times \frac{V_{IN} - I_{IN}R_{IN} - I_{OMAX}(R_{DS(ON)HSF} + R_{SENSE} + R_L) - V_O}{V_{IN} - I_{IN}R_{IN} - I_{OMAX}(R_{DS(ON)HSF} + R_{SENSE} + R_L - R_{DS(ON)LSF})} = 160\ \text{kHz} \quad (1)$$

ADP3153

The inductor peak current in normal operation is:

$$I_{LPEAK} = I_{OMAX} + I_{RPP}/2 = 15.3 A$$

The inductor valley current is:

$$I_{LVALLEY} = I_{LPEAK} - I_{RPP} = 13 A$$

The inductor for this application should have an inductance of 2.6 μH at full load current and should not saturate at the worst-case overload or short circuit current at the maximum specified ambient temperature. A suitable inductor is the CTX12-13855 from Coiltronics, which is 4.4 μH at 1 A and about 2.5 μH at 14.2 A.

Tips for Selecting Inductor Core

Ferrite designs have very low core loss, so the design should focus on copper loss and on preventing saturation. Molypermalloy, or MPP, is a low loss core material for toroids, and it yields the smallest size inductor, but MPP cores are more expensive than cores or the Kool M μ ® cores from Magnetics, Inc. The lowest cost core is made of powdered iron, for example the #52 material from Micrometals, Inc., but yields the largest size inductor.

C_O Selection—Determining the Capacitance

The minimum capacitance of the output capacitor is determined from the requirement that the output be held up while the inductor current ramps up (or down) to the new value. The minimum capacitance should produce an initial dv/dt which is equal (but opposite in sign) to the dv/dt obtained by multiplying the dt in the inductor and the ESR of the capacitor.

$$C_{MIN} = \frac{I_{OMAX} - I_{OMIN}}{R_E (di/dt)} = \frac{14.2 - 0.8}{5.9 m (2.2 / 4.4 \mu\text{H})} = 4.5 mF$$

In the above equation the value of di/dt is calculated as the smaller voltage across the inductor (i.e., $V_{IN} - V_O$ rather than V_O) divided by the maximum inductance (4.4 μH) of the CTX12-13855 inductor from Coiltronics. The parallel-connected six 2700 $\mu\text{F}/10 \text{ V}$ FA series capacitors from Panasonic have a total capacitance of 16,200 μF , so the minimum capacitance is met with ample margin.

R_{SENSE}

The value of R_{SENSE} is based on the required output current. The current comparator of the ADP3153 has a threshold range that extends from 0 mV to 125 mV (minimum). Note that the full 125 mV range cannot be used for the maximum specified nominal current, as headroom is needed for current ripple, transients and inductor core saturation.

The current comparator threshold sets the peak of the inductor current yielding a maximum output current I_{OMAX} , which equals the peak value less half of the peak-to-peak ripple current. Solving for R_{SENSE} and allowing a margin for tolerances inside the ADP3153 and in the external component values yields:

$$R_{SENSE} = (125 mV) / [1.2(I_{OMAX} + I_{RPP}/2)] = 6.8 m\Omega$$

A practical solution is to use three 20 $m\Omega$ resistors in parallel, with an effective resistance of about 6.7 $m\Omega$.

Once R_{SENSE} has been chosen, the peak short-circuit current $I_{SC(PK)}$ can be predicted from the following equation:

$$I_{SC(PK)} = (145 mV) / R_{SENSE} = (145 mV) / (6.7 m\Omega) = 21.5 A$$

The actual short-circuit current is less than the above calculated $I_{SC(PK)}$ value because the off time rapidly increases when the output voltage drops below 1 V. The relationship between the off time and the output voltage is:

$$t_{OFF} \approx \frac{C_T \times 1 V}{\frac{V_O}{360 k\Omega} + 2 \mu A}$$

With a short across the output, the off time will be about 70 μs . During that off time the inductor current gradually decays. The amount of decay depends on the L/R time constant in the output circuit. With an inductance of 2.5 μH and total resistance of 23 $m\Omega$, the time constant will be 108 μs , which yields a valley current of 11.3 A and an average short-circuit current of about 16.3 A. To safely carry the short-circuit current, the sense resistor must have a power rating of at least $16.3 A^2 \times 6.8 m\Omega = 1.8 \text{ W}$.

Current Transformer Option

An alternative to using low value and high power current sense resistor is to reduce the sensed current by using a low cost current transformer and a diode. The current can then be sensed with a small-size, low cost SMT resistor. If we use a transformer with one primary and 50 secondary turns, the worst-case resistor dissipation is reduced to a fraction of a mW. Another advantage of using this option is the separation of the current and voltage sensing, which makes the voltage sensing more accurate.

Power MOSFET

Two external N-channel power MOSFETs must be selected for use with the ADP3153, one for the main switch, and an identical one for the synchronous switch. The main selection parameters for the power MOSFETs are the threshold voltage $V_{GS(TH)}$ and the on resistance $R_{DS(ON)}$.

The minimum input voltage dictates whether standard threshold or logic-level threshold MOSFETs must be used. For $V_{IN} > 8 \text{ V}$, standard threshold MOSFETs ($V_{GS(TH)} < 4 \text{ V}$) may be used. If V_{IN} is expected to drop below 8 V, logic-level threshold MOSFETs ($V_{GS(TH)} < 2.5 \text{ V}$) are strongly recommended. Only logic-level MOSFETs with V_{GS} ratings higher than the absolute maximum of V_{CC} should be used.

The maximum output current I_{OMAX} determines the $R_{DS(ON)}$ requirement for the two power MOSFETs. When the ADP3153 is operating in continuous mode, the simplifying assumption can be made that one of the two MOSFETs is always conducting the average load current.

For $V_{IN} = 5 \text{ V}$ and $V_O = 2.8 \text{ V}$, the maximum duty ratio of the high side FET is:

$$D_{MAXHF} = (1 - f_{MIN} \times t_{OFF}) = (1 - 160 kHz \times 2.2 \mu s) = 65\%$$

The maximum duty ratio of the low side (synchronous rectifier) FET is:

$$D_{MAXLF} = 1 - D_{MAXHF} = 35\%$$

The maximum rms current of the high side FET is:

$$I_{RMSLS} = [D_{MAXHF} (I_{LVALLEY}^2 + I_{LPEAK}^2) + I_{LVALLEY} I_{LPEAK}] / 3]^{0.5} = 11.5 A_{rms}$$

The maximum rms current of the low side FET is:

$$I_{RMSLS} = [D_{MAXLF}(I_{LVALLEY}^2 + I_{LPEAK}^2 + I_{LVALLEY}I_{LPEAK})/3]^{0.5} = 8.41 \text{ Arms}$$

The $R_{DS(ON)}$ for each FET can be derived from the allowable dissipation. If we allow 5% of the maximum output power for FET dissipation, the total dissipation will be:

$$P_{FETALL} = 0.05 V_O I_{OMAX} = 2 \text{ W}$$

Allocating two-thirds of the total dissipation for the high side FET and one-third for the low side FET, the required minimum FET resistances will be:

$$R_{DS(ON)HSF(MIN)} = 1.33/11.5^2 = 10 \text{ m}\Omega$$

$$R_{DS(ON)LSF(MIN)} = 0.67/8.41^2 = 9.5 \text{ m}\Omega$$

Note that there is a tradeoff between converter efficiency and cost. Larger FETs reduce the conduction losses and allow higher efficiency but lead to increased cost. If efficiency is not a major concern the Fairchild MOSFET NDP6030L or International Rectifier IRL3103 is an economical choice for both the high side and low side positions. Those devices have an $R_{DS(ON)}$ of 14 m Ω at $V_{GS} = 10 \text{ V}$ and at 25°C. The low side FET is turned on with at least 10 V. The high side FET, however, is turned on with only 12 V – 5 V = 7 V. If we check the typical output characteristics of the device in the data sheet, we find that for an output current of 10 A, and at a V_{GS} of 7 V, the V_{DS} is 0.15 V, which gives a $R_{DS(ON)} = V_{DS}/I_D = 15 \text{ m}\Omega$. This value is only slightly above the one specified at a V_{GS} of 10 V, so the resistance increase due to the reduced gate drive can be neglected. We have to modify, however, the specified $R_{DS(ON)}$ at the expected highest FET junction temperature of 140°C by a $R_{DS(ON)}$ multiplier, using the graph in the data sheet. In our case:

$$R_{DS(ON)MULT} = 1.7$$

Using this multiplier, the expected $R_{DS(ON)}$ at 140°C is $1.7 \times 14 = 24 \text{ m}\Omega$.

The high side FET dissipation is:

$P_{DFETHS} = I_{RMSHS}^2 R_{DS(ON)} + 0.5 V_{IN} I_{LPEAK} Q_G f_{MAX} / I_G = 3.72 \text{ W}$
 where the second term represents the turn-off loss of the FET. (In the second term, Q_G is the gate charge to be removed from the gate for turn-off and I_G is the gate current. From the data sheet, Q_G is about 50 nC – 70 nC and the gate drive current provided by the ADP3153 is about 1 A.)

The low side FET dissipation is:

$$P_{DFETLS} = I_{RMSLS}^2 R_{DS(ON)} = 1.7 \text{ W}$$

(Note that there are no switching losses in the low side FET.)

To remove the dissipation of the chosen FETs, proper heatsinks should be used. The Thermalloy 6030 heatsink has a thermal impedance of 13°C/W with convection cooling. With this heatsink, the junction-to-ambient thermal impedance of the chosen high side FET θ_{JAHS} will be 13 (heatsink-to-ambient) + 2 (junction-to-case) + 0.5 (case-to-heatsink) = 15.5°C/W.

At full load and at 50°C ambient temperature, the junction temperature of the high side FET is:

$$T_{JHSMAX} = T_A + \theta_{JAHS} P_{DFETHS} = 105^\circ\text{C}$$

A smaller heatsink may be used for the low side FET, e.g., the Thermalloy type 7141 ($\theta = 20.3^\circ\text{C/W}$). With this heatsink, the

$$T_{JLSMAX} = T_A + \theta_{JALS} P_{DFETLS} = 106^\circ\text{C}$$

All of the above calculated junction temperatures are safely below the 175°C maximum specified junction temperature of the selected FET.

The maximum operating junction temperature of the ADP3153 is calculated as follows:

$$T_{JICMAX} = T_A + \theta_{JA} (I_{IC} V_{CC} + P_{DR})$$

where θ_{JA} is the junction to ambient thermal impedance of the ADP3153 and P_{DR} is the drive power. From the data sheet, θ_{JA} is equal to 110°C/W and $I_{IC} = 2.7 \text{ mA}$. P_{DR} can be calculated as follows:

$$P_{DR} = (C_{RSS} + C_{ISS}) V_{CC}^2 f_{MAX} = 307 \text{ mW}$$

The result is:

$$T_{JICMAX} = 86^\circ\text{C}$$

C_{IN} Selection and Input Current di/dt Reduction

In continuous-inductor-current mode, the source current of the high side MOSFET is a square wave with a duty ratio of V_O/V_{IN} . To keep the input ripple voltage at a low value, one or more capacitors with low equivalent series resistance (ESR) and adequate ripple-current rating must be connected across the input terminals. The maximum rms current of the input bypass capacitors is:

$$I_{CINRMS} \approx [V_O(V_{IN} - V_O)]^{0.5} I_{OMAX} / V_{IN} = 7 \text{ Arms}$$

Let us select the FA-type capacitor with 2700 μF capacitance and 10 V voltage rating. The ESR of that capacitor is 34 m Ω and the allowed ripple current at 100 kHz is 1.94 A. At 105°C we would need to connect at least four such capacitors in parallel to handle the calculated ripple current. At 50°C ambient, however, the ripple current can be increased, so three capacitors in parallel are adequate.

The ripple voltage across the three paralleled capacitors is:

$$V_{CINRPL} = I_{OMAX} [ESR_{IN}/3 + D_{MAXHF}/(3C_{IN}f_{MIN})] \approx 140 \text{ mV } p-p$$

To further reduce the effect of the ripple voltage on the system supply voltage bus and to reduce the input-current di/dt to below the recommended maximum of 0.1 A/ μs , an additional small inductor ($L > 1.7 \mu\text{H}$ @ 10 A) should be inserted between the converter and the supply bus (see Figure 2).

Feedback Loop Compensation Design

To keep the peak-to-peak output voltage deviation as small as possible, the low frequency output impedance (i.e., the output resistance) of the converter should be made equal to the ESR of the output capacitor. That can be achieved by having a single-pole roll-off of the voltage gain of the g_m error amplifier, where the pole frequency coincides with the ESR zero of the output capacitor. A gain with single-pole roll-off requires that the g_m amplifier is terminated by the parallel combination of a resistor and capacitor. The required resistor value can be calculated from the equation:

$$\frac{36 \times R_{SENSE}}{g_m (145 \text{ k}\Omega \parallel R_{COMP})} = R_E$$

where $g_m = 2.2 \text{ ms}$ and the quantities 36 and 145 k Ω are characteristic of the ADP3153. The calculated compensating resistance is:

$$R1 \parallel R2 = R_{COMP} = 31 \text{ k}\Omega$$

ADP3153

The compensating capacitance is determined from the equality of the pole frequency of the error amplifier gain and the zero frequency of the impedance of the output capacitor.

$$C_{COMP} = \frac{R_E C_{OUT}}{R_{COMP}} = \frac{5m \times 16.2mF}{31k\Omega} = 2.6nF$$

In the application circuit we tested, we found that the compensation scheme shown in Figure 2 gave the optimal response to meet the Pentium II dc/dc static and transient specifications with sufficient margins including the ADP3153's initial error tolerance, the PCB layout trace resistances, and the external component parasitics. If we increase the load resistance to the COMP pin, the static regulation will improve. The load transient response, however, will get worse. In Figure 2, if we decrease the R1 = 150 kΩ resistor vs. the R2 = 39 kΩ resistor, the regulation band will shift positive in relation to the 2.8 V. If we increase the R1 resistor, the regulation band will shift negative. It may be necessary to adjust these resistor values to obtain the best static and dynamic regulation compliance depending on the output capacitor ESR and the parasitic trace resistances of the PCB layout. A detailed design procedure and published conference papers on the optimal compensation are available on ADI's website (<http://www.analog.com>).

ADP3153 Linear Regulator

The ADP3153 linear regulator provides a low cost, convenient, and versatile solution for generating an additional power supply rail that can be programmed between 1.2 V–5 V. The maximum output load current is determined by the size and thermal impedance of an external N-channel power MOSFET that is placed in series with the 5 V supply and controlled by the ADP3153. The output voltage, V_{O2} in Figure 14, is sensed at the FB pin of the ADP3153 and compared to an internal 1.2 V reference in a negative feedback loop which keeps the output voltage in regulation. Thus, if the load is being reduced or increased, the FET drive will also be reduced or increased by the ADP3153 to provide a well regulated ±1% accurate output voltage. This accuracy is maintained even if the load changes at the very high rate typical of CPU-type loads. The output voltage is programmed by adjusting the value of the external resistor R_{PROG} shown in Figure 14.

Features

- Typical Efficiency: 66% at 3.3 V Output Voltage
- Tight DC Regulation Due to 1% Reference and High Gain
- Output Voltage Stays Within Specified Limits at Load Current Step with 30 A/μs Slope
- Fast Response to Input Voltage or Load Current Transients

The design in Figure 14 is for an output voltage, V_{O2} of 3.3 V with a maximum load current of 0.5 A. Additionally, overcurrent protection is provided by the addition of an external NPN transistor and an external resistor R_{S2}. The design specifications and procedure is given below.

Linear Regulator Design Specifications

Maximum Ambient Temperature	T _{AMB} = 50°C
Input Voltage	V _{IN} = 5 V
Output Voltage	V _{O2} = 3.3 V
Maximum Output Current	I _{O2MAX} = 0.5 A
Maximum Output Load Transient Allowed	..	V _{TR2} = 0.036 V
Chosen FET	IRX3803
Junction-to-Ambient Thermal Impedance (FET)*	θ _{JA} = 40°C/W

*Uses 1 inch square PCB cu-foil as heatsink

The output voltage may be programmed by the resistor R_{PROG} as follows:

$$R_{PROG} = \left(\frac{V_{O2}}{1.2} - 1 \right) \times 20k\Omega = \left(\frac{3.3}{1.2} - 1 \right) \times 20k\Omega = 35k\Omega$$

The current sense resistor may be calculated as follows:

$$R_{S2} = \frac{0.6}{I_{O2MAX}} = \frac{0.6}{0.5} = 1.2\Omega$$

The power rating is:

$$P_{S2} = R_{S2} \times (I_{O2MAX} \times 1.1)^2 = 0.36W$$

Use a 0.5 Ω resistor.

The maximum FET junction temperature at shorted output is:

$$T_{FETMAX} = T_{AMB} + \theta_{JA} \times V_{IN} \times I_{O2MAX} \times 1.1 = 50 + 40 \times 5 \times 0.5 \times 1.1 = 160^\circ C$$

which is within the maximum allowed by the FET's data sheet.

The maximum FET junction temperature at nominal output is:

$$T_{FETMAX} = T_{AMB} + \theta_{JA} \times (V_{IN} - V_{O2}) \times I_{O2MAX} = 50 + 40 \times (5 - 3.3) \times 0.5 = 84^\circ C$$

The output filter capacitor maximum allowed ESR is:

$$ESR \sim V_{TR2} / I_{O2MAX} = 0.036 / 0.5 = 0.072\Omega$$

This requirement is met using a 1000 μF/10 V LXV series capacitor from United Chemicon. For applications requiring higher output current, a heatsink and/or a larger MOSFET should be used to reduce the MOSFET's junction to ambient thermal impedance.

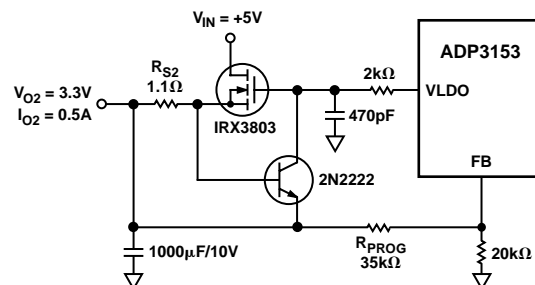

Figure 14. Linear Regulator with Overcurrent Protection

BOARD LAYOUT

A multilayer PCB is recommended with a minimum of two copper layers. One layer on top should be used for traces interconnecting low power SMT components. The ground terminals of those components should be connected with vias to the bottom traces connecting directly to the ADP3153 ground pins. One layer should be a power ground plane. If four layers are possible, one additional layer should be an internal system ground plane, and one additional layer can be used for other system interconnections.

When laying out the printed circuit board, the following checklist should be used to ensure proper operation of the ADP3153.

Board Layout Guidelines

1. The power loop should be routed on the PCB to encompass small areas to minimize radiated switching noise energy to the control circuit and thus to avoid circuit problems caused by noise. This technique also helps to reduce radiated EMI. The power loop includes the input capacitors, the two MOSFETs, the sense resistor, the inductor and the output capacitors. The ground terminals of the input capacitors, the low side FET, the ADP3153 and the output capacitors should be connected together with short and wide traces. It is best to use an internal ground plane.
2. The PGND (power ground) pin of the ADP3153 must return to the grounded terminals of the input and output capacitors and to the source of the low side MOSFET with the shortest and widest traces possible. The AGND (analog ground) pin has to be connected to the ground terminals of the timing capacitor and the compensating capacitor, again with the shortest leads possible, and before it is connected to the PGND pin.
3. The positive terminal of the input capacitors must be connected to the drain of the high side MOSFET. The source terminal of this FET is connected to the drain of the low side FET, (whose source is connected to the ground plane direct) with the widest and shortest traces possible. To kill parasitic ringing at the input of the buck inductor due to parasitic capacitances and inductances, a small ($L > 3$ mm) ferrite bead is recommended to be placed in the drain lead of the low side FET. Also, to minimize dissipation of the high side FET, a low voltage 1 A Schottky diode can be connected between the input of the buck inductor and the source of the low side FET.
4. The positive terminal of the bypass capacitors of the +12 V supply must be connected to the V_{IN} pin of the ADP3153 with the shortest leads possible. The negative terminals must be connected to the PGND pin of the ADP3153.
5. The sense pins of the ADP3153 must be connected to the sense resistor with as short traces as possible. Make sure that the two sense traces are routed together with minimum separation (<1 mm). The output side of the sense resistor should be connected to the V_{CC} pin(s) of the CPU with as short and wide PCB traces as possible to reduce the V_{CC} voltage drop. (Each square unit of 1 ounce Cu-trace has a resistance of ~ 0.53 m Ω . At 14 A, each m Ω of PCB trace resistance between current sense resistor output and V_{CC} terminal(s) of the CPU will reduce the regulated output voltage by 14 mV. The filter capacitors to ground at the sense terminals of the IC should be as close as possible (<8 mm) to the ADP3153. The common ground of the optional filter capacitors should be connected to the AGND pin of the ADP3153 with the shortest traces possible (<10 mm).
6. The microprocessor load should be connected to the output terminals of the converter with the widest and shortest traces possible. Use overlapping traces in different layers to minimize interconnection inductance.

ADP3153

OUTLINE DIMENSIONS

Dimensions shown in inches and (mm).

20-Lead Thin Shrink Small Outline (TSSOP) (RU-20)

