



ST93C66
ST93C67

4K (256 x 16 or 512 x 8) SERIAL MICROWIRE EEPROM

NOT FOR NEW DESIGN

- 1 MILLION ERASE/WRITE CYCLES, with 40 YEARS DATA RETENTION
- DUAL ORGANIZATION: 256 x 16 or 512 x 8
- BYTE/WORD and ENTIRE MEMORY PROGRAMMING INSTRUCTIONS
- SELF-TIMED PROGRAMMING CYCLE with AUTO-ERASE
- READY/BUSY SIGNAL DURING PROGRAMMING
- SINGLE SUPPLY VOLTAGE:
 - 4.5V to 5.5V for ST93C66 version
 - 3V to 5.5V for ST93C67 version
- SEQUENTIAL READ OPERATION
- 5ms TYPICAL PROGRAMMING TIME
- **ST93C66 and ST93C67 are replaced by the M93C66**

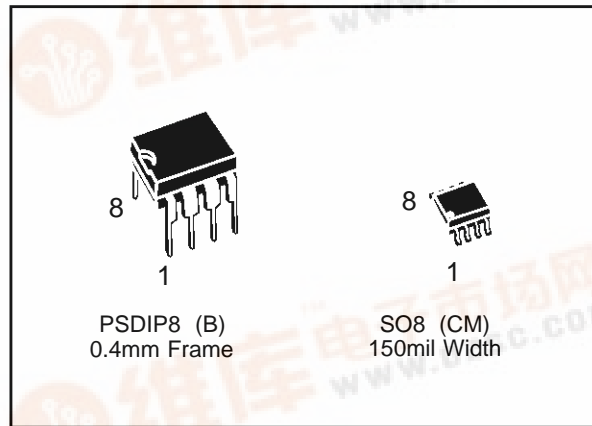

Figure 1. Logic Diagram

DESCRIPTION

This specification covers a range of 4K bit serial EEPROM products, the ST93C66 specified at 5V ± 10% and the ST93C67 specified at 3V to 5.5V. In the text, products are referred to as ST93C66.

The ST93C66 is a 4K bit Electrically Erasable Programmable Memory (EEPROM) fabricated with SGS-THOMSON's High Endurance Single Polysilicon CMOS technology. The memory is accessed through a serial input (D) and output (Q). The 4K bit memory is divided into either 512 x 8 bit bytes or 256 x 16 bit words. The organization may be selected by a signal applied on the ORG input.

Table 1. Signal Names

S	Chip Select Input
D	Serial Data Input
Q	Serial Data Output
C	Serial Clock
ORG	Organisation Select
Vcc	Supply Voltage
Vss	Ground

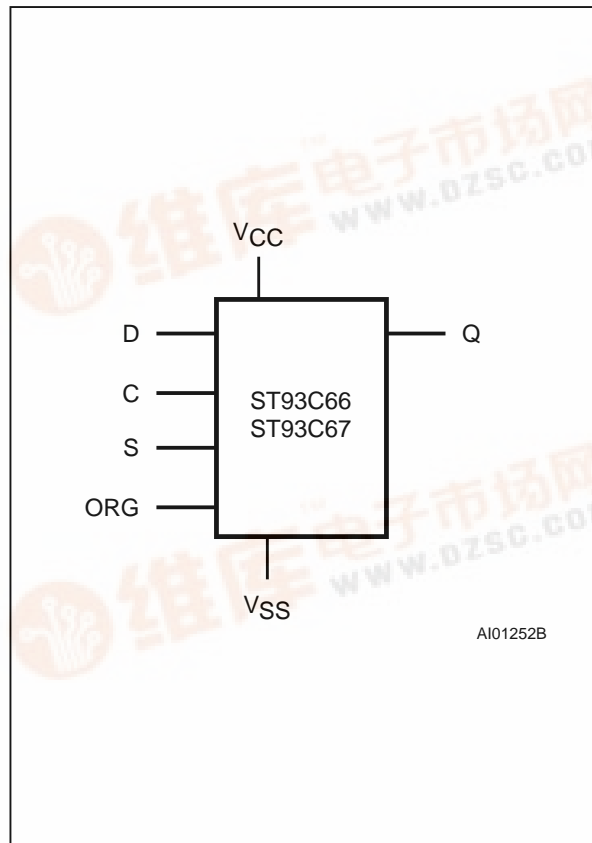

ST93C66, ST93C67

Figure 2A. DIP Pin Connections

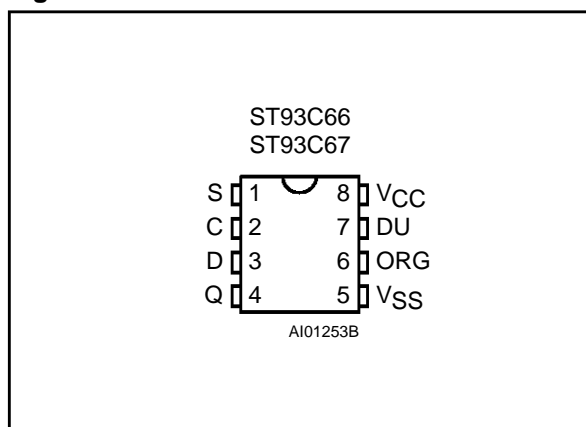

Warning: DU = Don't Use

Figure 2B. SO Pin Connections

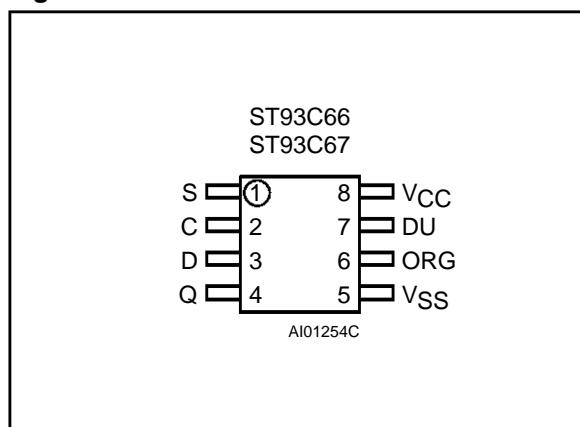

Warning: DU = Don't Use

Table 2. Absolute Maximum Ratings ⁽¹⁾

Symbol	Parameter	Value	Unit
T _A	Ambient Operating Temperature	-40 to 125	°C
T _{STG}	Storage Temperature	-65 to 150	°C
T _{LEAD}	Lead Temperature, Soldering (SO8 package) 40 sec (PSDIP8 package) 10 sec	215 260	°C
V _{IO}	Input or Output Voltages (Q = V _{OH} or Hi-Z)	-0.3 to V _{CC} +0.5	V
V _{CC}	Supply Voltage	-0.3 to 6.5	V
V _{ESD}	Electrostatic Discharge Voltage (Human Body model) ⁽²⁾	7000	V
	Electrostatic Discharge Voltage (Machine model) ⁽³⁾	1000	V

Notes: 1. Except for the rating "Operating Temperature Range", stresses above those listed in the Table "Absolute Maximum Ratings" may cause permanent damage to the device. These are stress ratings only and operation of the device at these or any other conditions above those indicated in the Operating sections of this specification is not implied. Exposure to Absolute Maximum Rating conditions for extended periods may affect device reliability. Refer also to the SGS-THOMSON SURE Program and other relevant quality documents.

2. MIL-STD-883C, 3015.7 (100pF, 1500 Ω).

3. EIAJ IC-121 (Condition C) (200pF, 0 Ω).

DESCRIPTION (cont'd)

The memory is accessed by a set of instructions which includes Read a byte/word, Write a byte/word, Erase a byte/word, Erase All and Write All. A Read instruction loads the address of the first byte/word to be read into an internal address pointer. The data contained at this address is then clocked out serially. The address pointer is automatically incremented after the data is output and, if the Chip Select input (S) is held High, the ST93C66 can output a sequential stream of data bytes/words. In this way, the memory can be read as a data stream from 8 to 4096 bits long, or continuously as the address counter automatically rolls over to '00' when the highest address is reached. Programming is internally self-timed (the external clock signal on C input may be discon-

nected or left running after the start of a Write cycle) and does not require an erase cycle prior to the Write instruction. The Write instruction writes 8 or 16 bits at one time into one of the 512 bytes or 256 words. After the start of the programming cycle, a Busy/Ready signal is available on the Data output (Q) when Chip Select (S) is driven High.

The design of the ST93C66 and the High Endurance CMOS technology used for its fabrication give an Erase/Write cycle Endurance of 1,000,000 cycles and a data retention of 40 years.

The DU (Don't Use) pin does not affect the function of the memory and it is reserved for use by SGS-THOMSON during test sequences. The pin may be left unconnected or may be connected to V_{CC} or V_{SS}. Direct connection of DU to V_{SS} is recommended for the lowest standby power consumption.

AC MEASUREMENT CONDITIONS

Input Rise and Fall Times	≤ 20ns
Input Pulse Voltages	0.4V to 2.4V
Input Timing Reference Voltages	1V to 2.0V
Output Timing Reference Voltages	0.8V to 2.0V

Note that Output Hi-Z is defined as the point where data is no longer driven.

Figure 3. AC Testing Input Output Waveforms

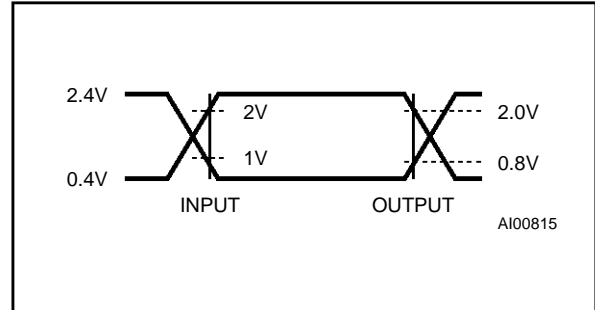

Table 3. Capacitance⁽¹⁾
(T_A = 25 °C, f = 1 MHz)

Symbol	Parameter	Test Condition	Min	Max	Unit
C _{IN}	Input Capacitance	V _{IN} = 0V		5	pF
C _{OUT}	Output Capacitance	V _{OUT} = 0V		5	pF

Note: 1. Sampled only, not 100% tested.

Table 4. DC Characteristics

(T_A = 0 to 70°C or -40 to 85°C; V_{CC} = 4.5V to 5.5V or 3V to 5.5V)

Symbol	Parameter	Test Condition	Min	Max	Unit
I _{LI}	Input Leakage Current	0V ≤ V _{IN} ≤ V _{CC}		±2.5	μA
I _{LO}	Output Leakage Current	0V ≤ V _{OUT} ≤ V _{CC} , Q in Hi-Z		±2.5	μA
I _{CC}	Supply Current (TTL Inputs)	S = V _{IH} , f = 1 MHz		3	mA
	Supply Current (CMOS Inputs)	S = V _{IH} , f = 1 MHz		2	mA
I _{CC1}	Supply Current (Standby)	S = V _{SS} , C = V _{SS} , ORG = V _{SS} or V _{CC}		50	μA
V _{IL}	Input Low Voltage (D, C, S)	V _{CC} = 5V ± 10%	-0.3	0.8	V
		3V ≤ V _{CC} ≤ 4.5V	-0.3	0.2 V _{CC}	V
V _{IH}	Input High Voltage (D, C, S)	V _{CC} = 5V ± 10%	2	V _{CC} + 1	V
		3V ≤ V _{CC} ≤ 4.5V	0.8 V _{CC}	V _{CC} + 1	V
V _{OL}	Output Low Voltage	I _{OL} = 2.1mA		0.4	V
		I _{OL} = 10 μA		0.2	V
V _{OH}	Output High Voltage	I _{OH} = -400μA	2.4		V
		I _{OH} = -10μA	V _{CC} - 0.2		V

ST93C66, ST93C67

Table 5. AC Characteristics

($T_A = 0$ to 70°C or -40 to 85°C ; $V_{CC} = 4.5\text{V}$ to 5.5V or 3V to 5.5V)

Symbol	Alt	Parameter	Test Condition	Min	Max	Unit
t_{SHCH}	t_{CSS}	Chip Select High to Clock High		50		ns
t_{CLSH}	t_{SKS}	Clock Low to Chip Select High		100		ns
t_{DVCH}	t_{DIS}	Input Valid to Clock High		100		ns
t_{CHDX}	t_{DIH}	Clock High to Input Transition	Temp. Range: grade 1	100		ns
			Temp. Range: grades 3, 6	200		ns
t_{CHQL}	t_{PD0}	Clock High to Output Low			500	ns
t_{CHQV}	t_{PD1}	Clock High to Output Valid			500	ns
t_{CLSL}	t_{CSH}	Clock Low to Chip Select Low		0		ns
t_{SLCH}		Chip Select Low to Clock High		250		ns
t_{SLSH}	t_{CS}	Chip Select Low to Chip Select High	Note 1	250		ns
t_{SHQV}	t_{SV}	Chip Select High to Output Valid			500	ns
t_{SLQZ}	t_{DF}	Chip Select Low to Output Hi-Z			200	ns
t_{CHCL}	t_{SKH}	Clock High to Clock Low	Note 2	250		ns
t_{CLCH}	t_{SKL}	Clock Low to Clock High	Note 2	250		ns
t_w	t_{WP}	Erase/Write Cycle time			10	ms
f_c	f_{SK}	Clock Frequency		0	1	MHz

Notes: 1. Chip Select must be brought low for a minimum of 250 ns (t_{SLSH}) between consecutive instruction cycles.

2. The Clock frequency specification calls for a minimum clock period of 1 μs , therefore the sum of the timings $t_{CHCL} + t_{CLCH}$ must be greater or equal to 1 μs . For example, if t_{CHCL} is 250 ns, then t_{CLCH} must be at least 750 ns.

Figure 4. Synchronous Timing, Start and Op-Code Input

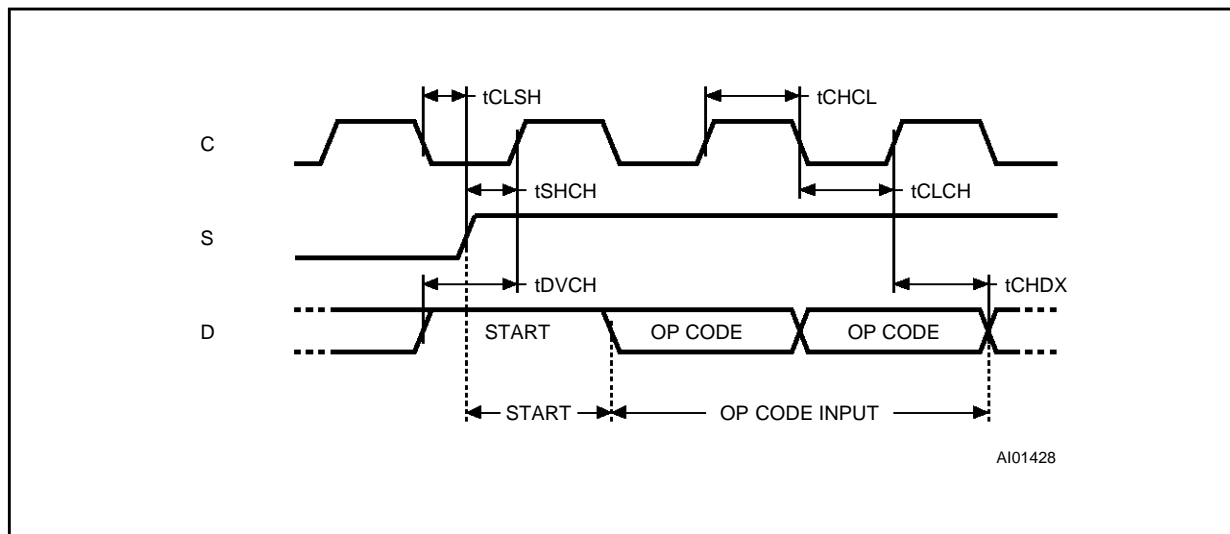
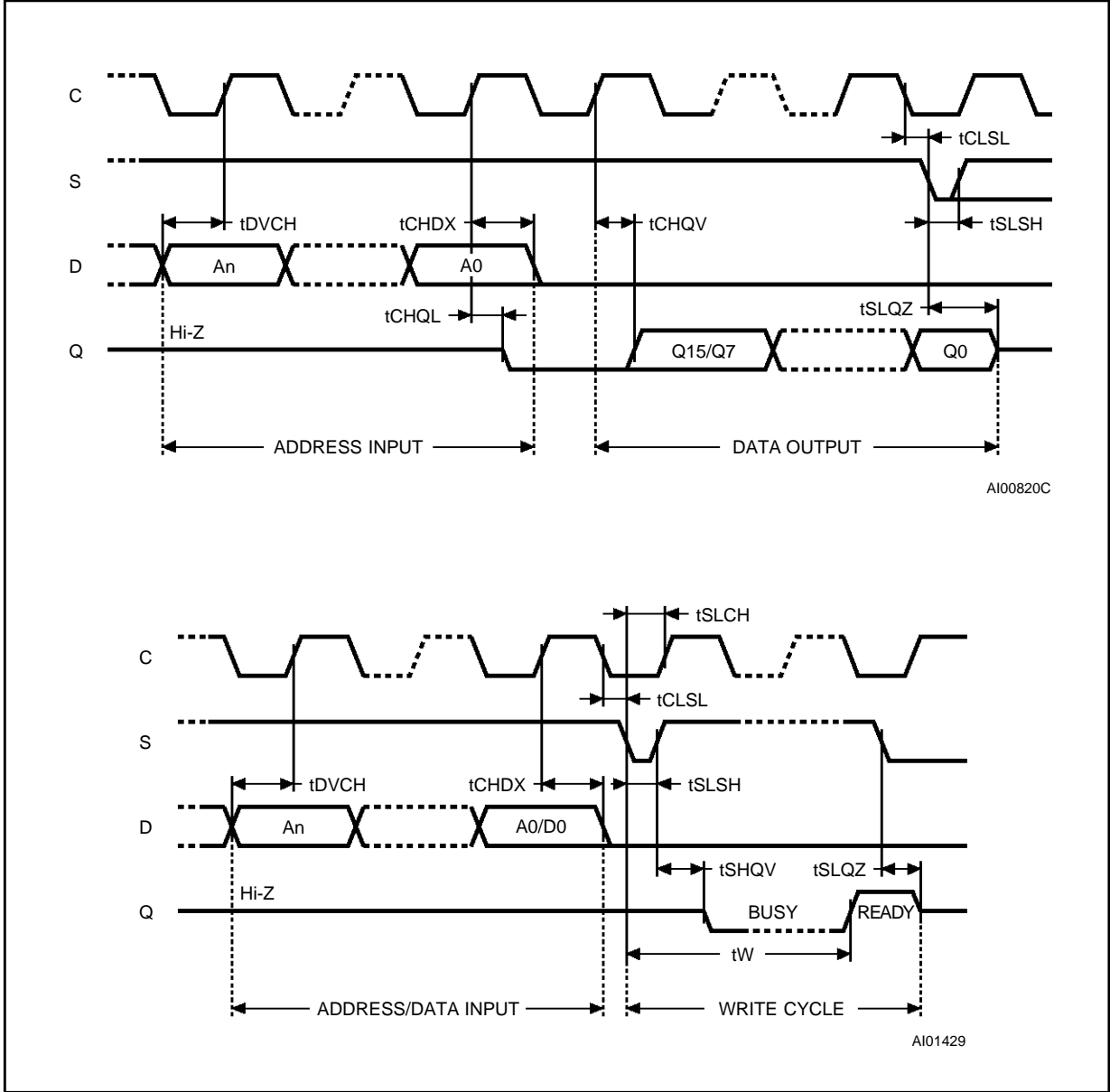

Figure 5. Synchronous Timing, Read or Write



MEMORY ORGANIZATION

The ST93C66 is organized as 512 bytes x 8 bits or 256 words x 16 bits. If the ORG input is left unconnected (or connected to V_{CC}) the x16 organization is selected, when ORG is connected to Ground (V_{SS}) the x8 organization is selected. When the ST93C66 is in standby mode, the ORG input should be unconnected or set to either V_{SS} or V_{CC} in order to achieve the minimum power consumption. Any voltage between V_{SS} and V_{CC} applied to ORG may increase the standby current value.

POWER-ON DATA PROTECTION

In order to prevent data corruption and inadvertent write operations during power up, a Power On Reset (POR) circuit resets all internal programming circuitry and sets the device in the Write Disable mode. When V_{CC} reaches its functional value, the device is properly reset (in the Write Disable mode) and is ready to decode and execute an incoming instruction. A stable V_{CC} must be applied, before applying any logic signal.

INSTRUCTIONS

The ST93C66 has seven instructions, as shown in Table 6. The op-codes of the instructions are made up of 2 bits. The op-code is followed by an address for the byte/word which is eight bits long for the x16 organization or nine bits long for the x8 organization. Each instruction is preceded by the rising edge of the signal applied on the Chip Select (S) input (assuming that the Clock C is low). The data input D is then sampled upon the following rising edges of the clock C until a '1' is sampled and decoded by the ST93C66 as a Start bit.

The ST93C66 is fabricated in CMOS technology and is therefore able to run from zero Hz (static input signals) up to the maximum ratings (specified in Table 5).

Read

The Read instruction (READ) outputs serial data on the Data Output (Q). When a READ instruction is received, the instruction and address are decoded and the data from the memory is transferred into an output shift register. A dummy '0' bit is output first, followed by the 8 bit byte or the 16 bit word with the MSB first. Output data changes are triggered by the Low to High transition of the Clock (C). The ST93C66 will automatically increment the address and will clock out the next byte/word as long as the Chip Select input (S) is held High. In this case the dummy '0' bit is NOT output between bytes/words and a continuous stream of data can be read.

Erase/Write Enable and Disable

The Erase/Write Enable instruction (EWEN) authorizes the following Erase/Write instructions to be executed, the Erase/Write Disable instruction

(EWDS) disables the execution of the following Erase/Write instructions. When power is first applied, the ST93C66 enters the Disable mode. When the EWEN instruction is executed, Write instructions remain enabled until an Erase/Write Disable instruction (EWDS) is executed or V_{CC} falls below the power-on reset threshold. To protect the memory contents from accidental corruption, it is advisable to issue the EWDS instruction after every write cycle.

The READ instruction is not affected by the EWEN or EWDS instructions.

Erase

The Erase instruction (ERASE) programs the addressed memory byte or word bits to '1'. Once the address is correctly decoded, the falling edge of the Chip Select input (S) triggers a self-timed erase cycle.

If the ST93C66 is still performing the erase cycle, the Busy signal (Q = 0) will be returned if S is driven high, and the ST93C66 will ignore any data on the bus. When the erase cycle is completed, the Ready signal (Q = 1) will indicate (if S is driven high) that the ST93C66 is ready to receive a new instruction.

Write

The Write instruction (WRITE) is followed by the address and the 8 or 16 data bits to be written. Data input is sampled on the Low to High transition of the clock. After the last data bit has been sampled, Chip Select (S) must be brought Low before the next rising edge of the clock (C) in order to start the self-timed programming cycle. If the ST93C66 is still performing the write cycle, the Busy signal (Q = 0) will be returned if S is driven high, and the ST93C66 will ignore any data on the bus.

Table 6. Instruction Set

Instruction	Description	Op-Code	x8 Org Address (ORG = 0) ⁽¹⁾	Data	x16 Org Address (ORG = 1) ⁽¹⁾	Data
READ	Read Data from Memory	10	A8-A0	Q7-Q0	A7-A0	Q15-Q0
WRITE	Write Data to Memory	01	A8-A0	D7-D0	A7-A0	D15-D0
EWEN	Erase/Write Enable	00	11XXX XXXX		11XX XXXX	
EWDS	Erase/Write Disable	00	00XXX XXXX		00XX XXXX	
ERASE	Erase Byte or Word	11	A8-A0		A7-A0	
ERAL	Erase All Memory	00	10XXX XXXX		10XX XXXX	
WRAL	Write All Memory with same Data	00	01XXX XXXX	D7-D0	01XX XXXX	D15-D0

Note: 1. X = don't care bit.

Figure 6. READ, WRITE, EWEN, EWDS Sequences

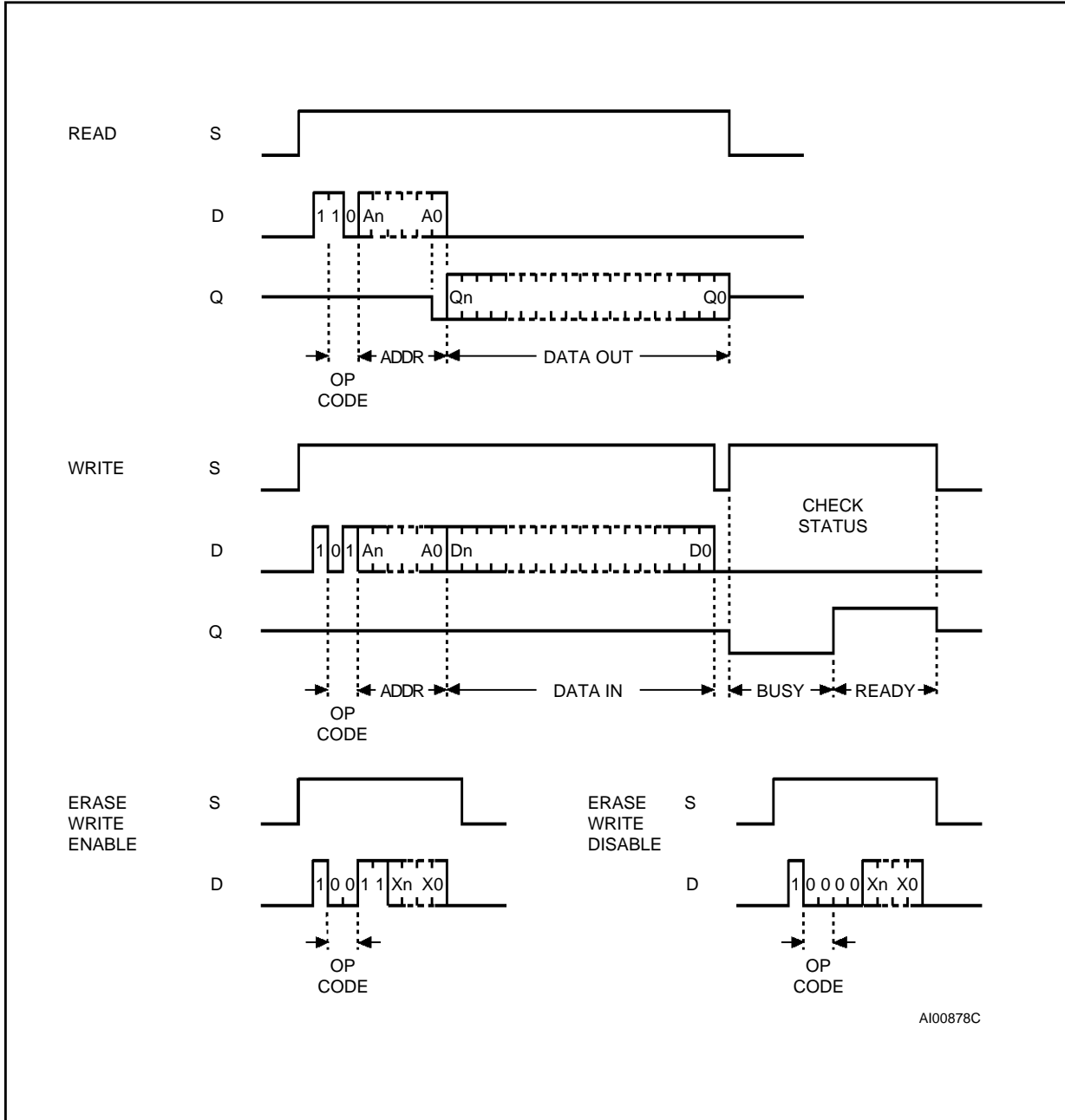

Notes: 1. An: n = 7 for x16 org. and 8 for x8 org.
 2. Xn: n = 5 for x16 org. and 6 for x8 org.

When the write cycle is completed, the Ready signal (Q = 1) will indicate (if S is driven high) that the ST93C66 is ready to receive a new instruction. Programming is internally self-timed (the external clock signal on C input may be disconnected or left

running after the start of a programming cycle) and does not require an Erase instruction prior to the Write instruction (The Write instruction includes an automatic erase cycle before programming data).

Figure 7. ERASE, ERAL Sequences

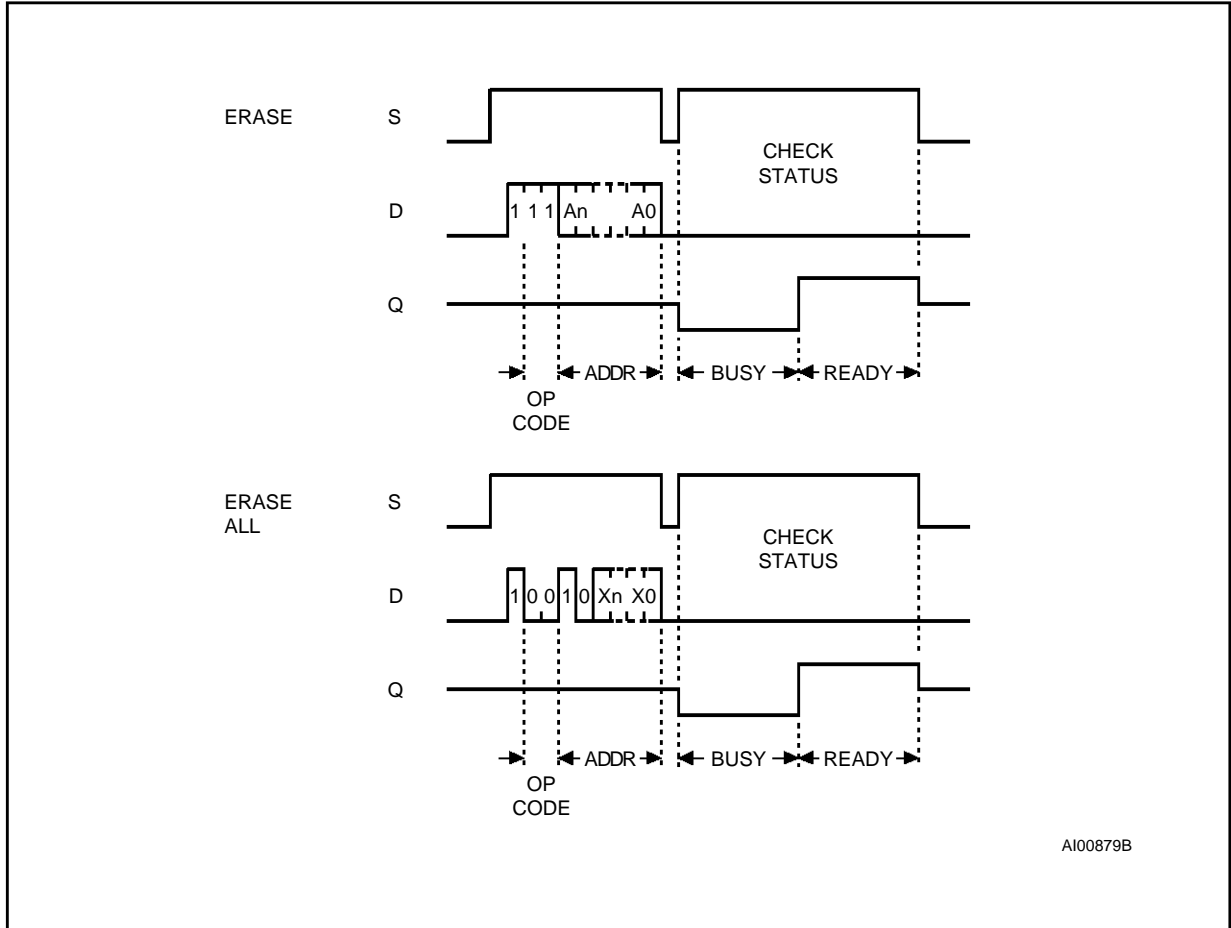

Notes: 1. A_n : $n = 7$ for x16 org. and 8 for x8 org.
 2. X_n : $n = 5$ for x16 org. and 6 for x8 org.

Figure 8. WRAL Sequence

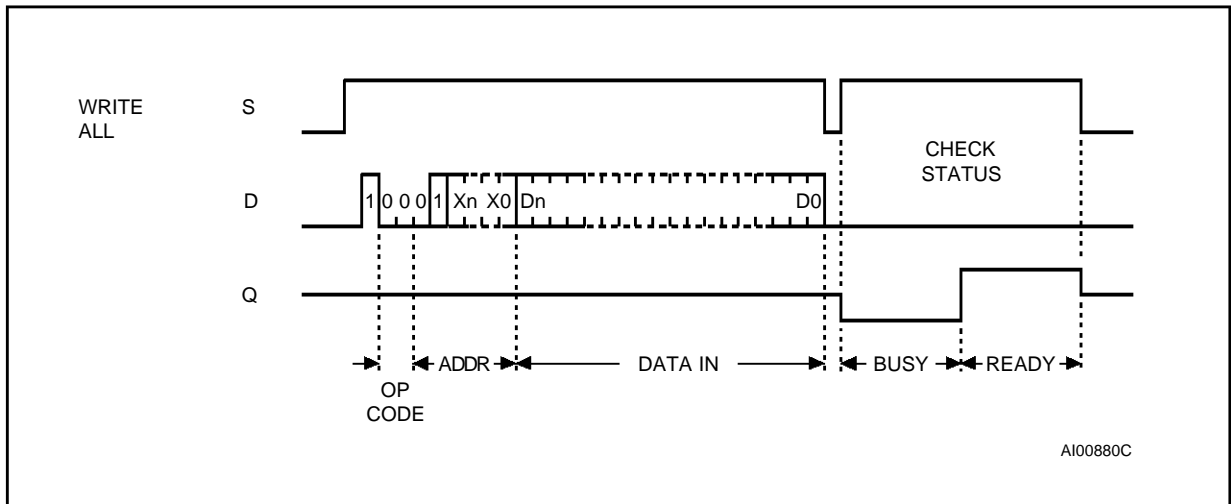

Note: 2. X_n : $n = 5$ for x16 org. and 6 for x8 org.

Erase All

The Erase All instruction (ERAL) erases the whole memory (all memory bits are set to '1'). A dummy address is input during the instruction transfer and the erase is made in the same way as the ERASE instruction. If the ST93C66 is still performing the erase cycle, the Busy signal ($Q = 0$) will be returned if S is driven high, and the ST93C66 will ignore any data on the bus. When the erase cycle is completed, the Ready signal ($Q = 1$) will indicate (if S is driven high) that the ST93C66 is ready to receive a new instruction.

Write All

For correct operation, an ERAL instruction should be executed before the WRAL instruction: the WRAL instruction DOES NOT perform an automatic erase before writing. The Write All instruction (WRAL) writes the Data Input byte or word to all the addresses of the memory. If the ST93C66 is still performing the write cycle, the Busy signal ($Q = 0$) will be returned if S is driven high, and the ST93C66 will ignore any data on the bus. When the write cycle is completed, the Ready signal ($Q = 1$) will indicate (if S is driven high) that the ST93C66 is ready to receive a new instruction.

READY/BUSY Status

During every programming cycle (after a WRITE, ERASE, WRAL or ERAL instruction) the Data Output (Q) indicates the Ready/Busy status of the memory when the Chip Select (S) is driven High. Once the ST93C66 is Ready, the Ready/Busy status is available on the Data Output (Q) until a new start bit is decoded or the Chip Select (S) is brought Low.

COMMON I/O OPERATION

The Data Output (Q) and Data Input (D) signals can be connected together, through a current limiting resistor, to form a common, one wire data bus. Some precautions must be taken when operating the memory with this connection, mostly to prevent a short circuit between the last entered address bit (A0) and the first data bit output by Q. The reader may also refer to the SGS-THOMSON application note "MICROWIRE EEPROM Common I/O Operation".

CLOCK PULSE COUNTER

The ST93C66 offers a functional security filtering glitches on the clock input (C), the Clock pulse counter.

In a normal environment, the ST93C66 expects to receive the exact amount of data on the D input, that is, the exact amount of clock pulses on the C input.

In a noisy environment, the number of pulses received (on the clock input C) may be greater than the clock pulses delivered by the Master (Microcontroller) driving the ST93C66. In such a case, a part of the instruction is delayed by one bit (see Figure 9), and it may induce an erroneous write of data at a wrong address.

The ST93C66 has an on-chip counter which counts the clock pulses from the Start bit until the falling edge of the Chip Select signal. For the WRITE instructions, the number of clock pulses incoming to the counter must be exactly 20 (with the Organisation by 8) from the Start bit to the falling edge of Chip Select signal (1 Start bit + 2 bits of Op-code + 9 bits of Address + 8 bits of Data = 20): if so, the ST93C66 executes the WRITE instruction; if the number of clock pulses is not equal to 20, the instruction will not be executed (and data will not be corrupted).

In the same way, when the Organisation by 16 is selected, the number of clock pulses incoming to the counter must be exactly 27 (1 Start bit + 2 bits of Op-code + 8 bits of Address + 16 bits of Data = 27) from the Start bit to the falling edge of Chip Select signal: if so, the ST93C66 executes the WRITE instruction; if the number of clock pulses is not equal to 27, the instruction will not be executed (and data will not be corrupted). The clock pulse counter is active only on ERASE and WRITE instructions (WRITE, ERASE, ERAL, WRALL).

Figure 9. WRITE Sequence with One Clock Glitch

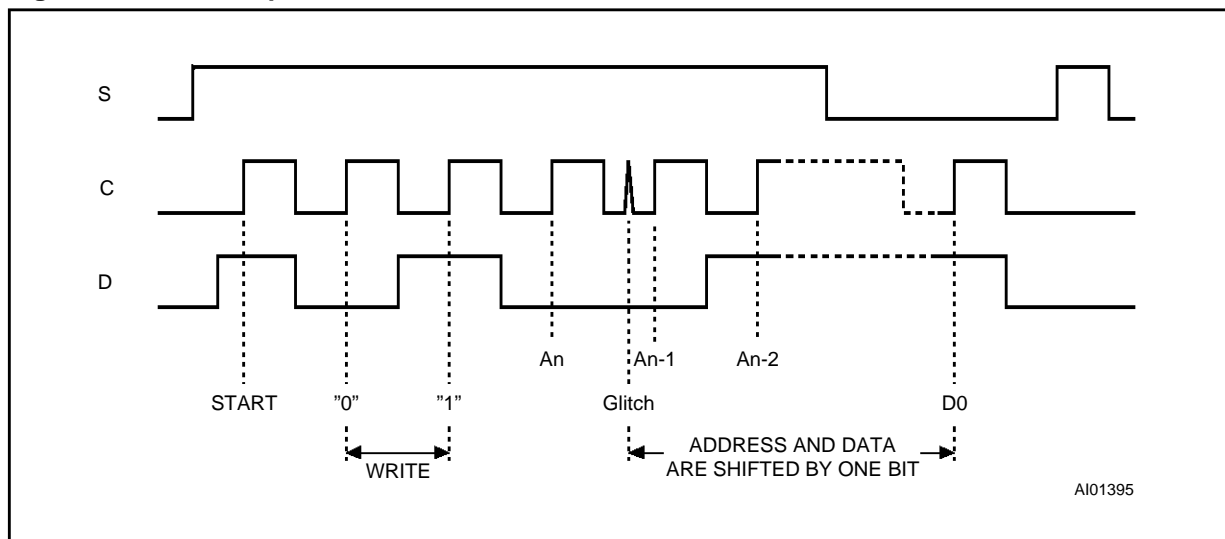

ORDERING INFORMATION SCHEME

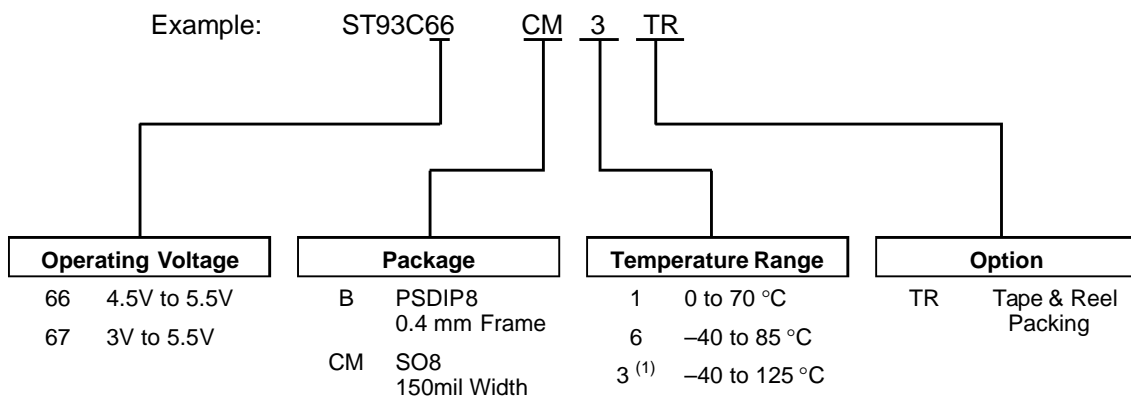

Note: 1. Temperature range on request only.

Devices are shipped from the factory with the memory content set at all "1's" (FFFFh for x16, FFh for x8).

For a list of available options (Operating Voltage, Package, etc...) or for further information on any aspect of this device, please contact the SGS-THOMSON Sales Office nearest to you.

PSDIP8 - 8 pin Plastic Skinny DIP, 0.4mm lead frame

Symb	mm			inches		
	Typ	Min	Max	Typ	Min	Max
A			4.80			0.189
A1		0.70	–		0.028	–
A2		3.10	3.60		0.122	0.142
B		0.38	0.58		0.015	0.023
B1		1.15	1.65		0.045	0.065
C		0.38	0.52		0.015	0.020
D		9.20	9.90		0.362	0.390
E	7.62	–	–	0.300	–	–
E1		6.30	7.10		0.248	0.280
e1	2.54	–	–	0.100	–	–
eA		8.40	–		0.331	–
eB			9.20			0.362
L		3.00	3.80		0.118	0.150
N		8			8	
CP			0.10			0.004

PSDIP8

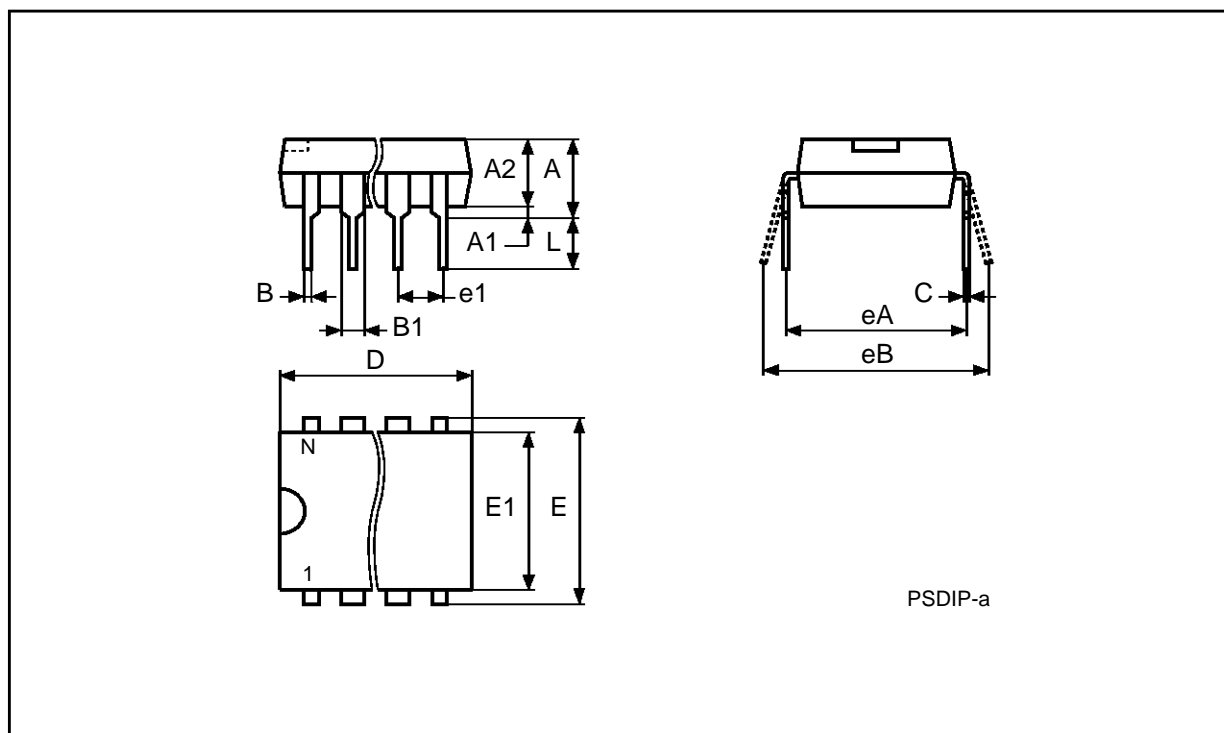

Drawing is not to scale.

SO8 - 8 lead Plastic Small Outline, 150 mils body width

Symb	mm			inches		
	Typ	Min	Max	Typ	Min	Max
A		1.35	1.75		0.053	0.069
A1		0.10	0.25		0.004	0.010
B		0.33	0.51		0.013	0.020
C		0.19	0.25		0.007	0.010
D		4.80	5.00		0.189	0.197
E		3.80	4.00		0.150	0.157
e	1.27	–	–	0.050	–	–
H		5.80	6.20		0.228	0.244
h		0.25	0.50		0.010	0.020
L		0.40	0.90		0.016	0.035
α		0°	8°		0°	8°
N	8			8		
CP			0.10			0.004

SO8

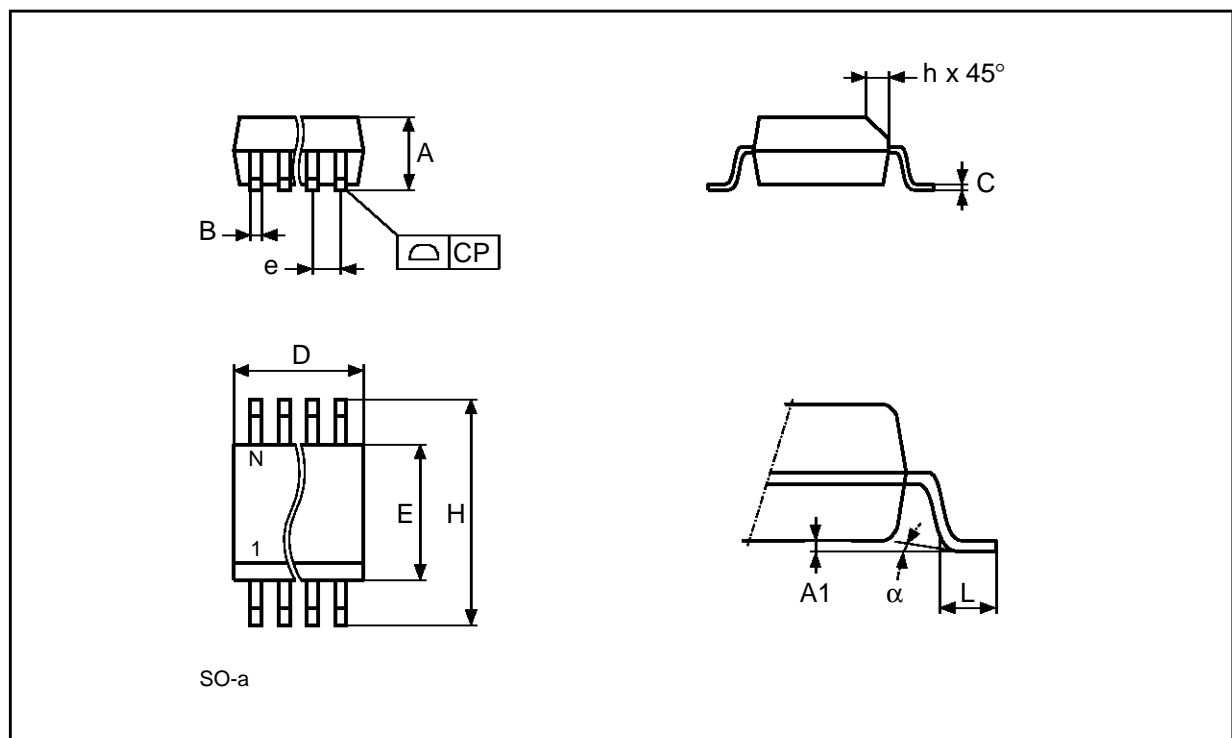

Drawing is not to scale.

Information furnished is believed to be accurate and reliable. However, SGS-THOMSON Microelectronics assumes no responsibility for the consequences of use of such information nor for any infringement of patents or other rights of third parties which may result from its use. No license is granted by implication or otherwise under any patent or patent rights of SGS-THOMSON Microelectronics. Specifications mentioned in this publication are subject to change without notice. This publication supersedes and replaces all information previously supplied. SGS-THOMSON Microelectronics products are not authorized for use as critical components in life support devices or systems without express written approval of SGS-THOMSON Microelectronics.

© 1997 SGS-THOMSON Microelectronics - All Rights Reserved

® MICROWIRE is a registered trademark of National Semiconductor Corp.

SGS-THOMSON Microelectronics GROUP OF COMPANIES
Australia - Brazil - Canada - China - France - Germany - Hong Kong - Italy - Japan - Korea - Malaysia - Malta - Morocco - The Netherlands -
Singapore - Spain - Sweden - Switzerland - Taiwan - Thailand - United Kingdom - U.S.A.