



Active RC, 4th Order Lowpass Filter Family

January 2000

FEATURES

- Extremely Easy to Use—A Single Resistor Value Sets the Cutoff Frequency ($2.56\text{kHz} < f_c < 256\text{kHz}$)
- Extremely Flexible—Different Resistor Values Allow Arbitrary Transfer Functions with or without Gain ($2.56\text{kHz} < f_c < 256\text{kHz}$)
- LTC1563-2: Unity-Gain Butterworth Response Uses a Single Resistor Value, Different Resistor Values Allow Other Responses with or without Gain
- LTC1563-3: Unity-Gain Bessel Response Uses a Single Resistor Value, Different Resistor Values Allow Other Responses with or without Gain
- Rail-to-Rail Input and Output Voltages
- Operates from a Single 3V (2.7V Min) to $\pm 5\text{V}$ Supply
- Low Noise: $36\mu\text{V}_{\text{RMS}}$ for $f_c = 25.6\text{kHz}$, $60\mu\text{V}_{\text{RMS}}$ for $f_c = 256\text{kHz}$
- f_c Accuracy $< \pm 2\%$ (Typ)
- DC Offset $< 1\text{mV}$
- Cascadable to Form 8th Order Lowpass Filters
- Low Power Mode, $f_c < 25.6\text{kHz}$, $I_{\text{SUPPLY}} = 1\text{mA}$ (Typ)
- High Speed Mode, $f_c < 256\text{kHz}$, $I_{\text{SUPPLY}} = 10\text{mA}$ (Typ)
- Shutdown Mode, $I_{\text{SUPPLY}} = 1\mu\text{A}$ (Typ)
- Continuous Time, Active RC Filter, No Clock

APPLICATIONS

- Replaces Discrete RC Active Filters and Modules
- Antialiasing Filters
- Smoothing or Reconstruction Filters
- Linear Phase Filtering for Data Communication
- Phase Locked Loops

DESCRIPTION

The LTC[®]1563-2/LTC1563-3 are a family of extremely easy-to-use, active RC lowpass filters with rail-to-rail inputs and outputs and low DC offset suitable for systems with a resolution of up to 16 bits. The LTC1563-2, with a single resistor value, gives a unity-gain Butterworth response. The LTC1563-3, with a single resistor value, gives a unity-gain Bessel response. The proprietary architecture of these parts allows for a simple resistor calculation:

$$R = 10\text{k} (256\text{kHz}/f_c); f_c = \text{Cutoff Frequency}$$

where f_c is the desired cutoff frequency. For many applications, this formula is all that is needed to design a filter. By simply utilizing different valued resistors, gain and other responses are achieved.

The LTC1563-X features a low power mode, for the lower frequency applications, where the supply current is reduced by an order of magnitude and a near zero power shutdown mode.

The LTC1563-Xs are available in the narrow SSOP-16 package (SO-8 footprint).

LTC, LTC and LT are registered trademarks of Linear Technology Corporation.

TYPICAL APPLICATION

Single 3.3V, 2.56kHz to 256kHz Butterworth Lowpass Filter

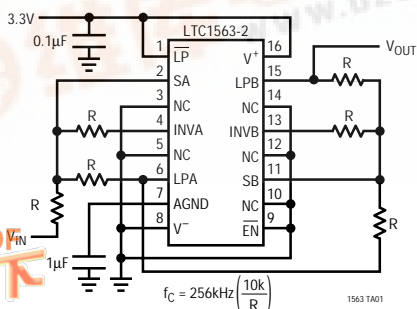

Frequency Response

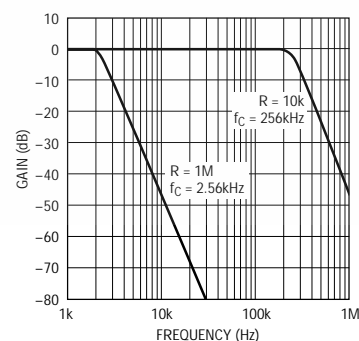

LTC1563-2/LTC1563-3

ABSOLUTE MAXIMUM RATINGS

(Note 1)

Total Supply Voltage (V^+ to V^-)	11V
Maximum Input Voltage at Any Pin	$(V^- - 0.3V) \leq V_{PIN} \leq (V^+ + 0.3V)$
Power Dissipation	500mW
Operating Temperature Range	
LTC1563C	0°C to 70°C
LTC1563I	-40°C to 85°C
Storage Temperature Range	-65°C to 150°C
Lead Temperature (Soldering, 10 sec)	300°C

PACKAGE/ORDER INFORMATION

<p>GN PACKAGE 16-LEAD NARROW PLASTIC SSOP $T_{JMAX} = 150^\circ\text{C}$, $\theta_{JA} = 135^\circ\text{C/W}$</p> <p>NOTE: PINS LABELED NC ARE NOT CONNECTED INTERNALLY AND SHOULD BE CONNECTED TO THE SYSTEM GROUND</p>	<p>ORDER PART NUMBER</p> <p>LTC1563-2CGN LTC1563-3CGN LTC1563-2IGN LTC1563-3IGN</p>
--	---

Consult factory for Military grade parts.

ELECTRICAL CHARACTERISTICS

The ● denotes specifications which apply over the full operating temperature range, otherwise specifications are $T_A = 25^\circ\text{C}$.

$V_S = \text{Single } 4.75\text{V}$, $\overline{\text{EN}}$ pin to logic "low," Gain = 1, $R_{FIL} = R11 = R21 = R31 = R12 = R22 = R32$, specifications apply to both the high speed (HS) and low power (LP) modes unless otherwise noted.

PARAMETER	CONDITIONS	MIN	TYP	MAX	UNITS
Specifications for Both LTC1563-2 and LTC1563-3					
Total Supply Voltage (V_S), HS Mode	●	3		11	V
Total Supply Voltage (V_S), LP Mode	●	2.7		11	V
Positive Output Voltage Swing (LPB Pin) HS Mode	$V_S = 3\text{V}$, $f_C = 25.6\text{kHz}$, $R_{FIL} = 100\text{k}$, $R_L = 10\text{k}$ to GND	●	2.9	2.95	V
	$V_S = 4.75\text{V}$, $f_C = 25.6\text{kHz}$, $R_{FIL} = 100\text{k}$, $R_L = 10\text{k}$ to GND	●	4.55	4.7	V
	$V_S = \pm 5\text{V}$, $f_C = 25.6\text{kHz}$, $R_{FIL} = 100\text{k}$, $R_L = 10\text{k}$ to GND	●	4.8	4.9	V
Negative Output Voltage Swing (LPB Pin) HS Mode	$V_S = 3\text{V}$, $f_C = 25.6\text{kHz}$, $R_{FIL} = 100\text{k}$, $R_L = 10\text{k}$ to GND	●		0.015	0.05
	$V_S = 4.75\text{V}$, $f_C = 25.6\text{kHz}$, $R_{FIL} = 100\text{k}$, $R_L = 10\text{k}$ to GND	●		0.02	0.05
	$V_S = \pm 5\text{V}$, $f_C = 25.6\text{kHz}$, $R_{FIL} = 100\text{k}$, $R_L = 10\text{k}$ to GND	●		-4.95	-4.9
Positive Output Swing (LPB Pin) LP Mode	$V_S = 2.7\text{V}$, $f_C = 25.6\text{kHz}$, $R_{FIL} = 100\text{k}$, $R_L = 10\text{k}$ to GND	●	2.6	2.65	V
	$V_S = 4.75\text{V}$, $f_C = 25.6\text{kHz}$, $R_{FIL} = 100\text{k}$, $R_L = 10\text{k}$ to GND	●	4.55	4.65	V
	$V_S = \pm 5\text{V}$, $f_C = 25.6\text{kHz}$, $R_{FIL} = 100\text{k}$, $R_L = 10\text{k}$ to GND	●	4.8	4.9	V
Negative Output Swing (LPB Pin) LP Mode	$V_S = 2.7\text{V}$, $f_C = 25.6\text{kHz}$, $R_{FIL} = 100\text{k}$, $R_L = 10\text{k}$ to GND	●		0.01	0.05
	$V_S = 4.75\text{V}$, $f_C = 25.6\text{kHz}$, $R_{FIL} = 100\text{k}$, $R_L = 10\text{k}$ to GND	●		0.015	0.05
	$V_S = \pm 5\text{V}$, $f_C = 25.6\text{kHz}$, $R_{FIL} = 100\text{k}$, $R_L = 10\text{k}$ to GND	●		-4.95	-4.9
DC Offset Voltage, HS Mode (Section A Only)	$V_S = 3\text{V}$, $f_C = 25.6\text{kHz}$, $R_{FIL} = 100\text{k}$	●		± 1.5	± 3
	$V_S = 4.75\text{V}$, $f_C = 25.6\text{kHz}$, $R_{FIL} = 100\text{k}$	●		± 1.0	± 3
	$V_S = \pm 5\text{V}$, $f_C = 25.6\text{kHz}$, $R_{FIL} = 100\text{k}$	●		± 1.5	± 3
DC Offset Voltage, LP Mode (Section A Only)	$V_S = 2.7\text{V}$, $f_C = 25.6\text{kHz}$, $R_{FIL} = 100\text{k}$	●		± 2	± 4
	$V_S = 4.75\text{V}$, $f_C = 25.6\text{kHz}$, $R_{FIL} = 100\text{k}$	●		± 2	± 4
	$V_S = \pm 5\text{V}$, $f_C = 25.6\text{kHz}$, $R_{FIL} = 100\text{k}$	●		± 2	± 5
DC Offset Voltage, HS Mode (Input to Output, Sections A, B Cascaded)	$V_S = 3\text{V}$, $f_C = 25.6\text{kHz}$, $R_{FIL} = 100\text{k}$	●		± 1.5	± 3
	$V_S = 4.75\text{V}$, $f_C = 25.6\text{kHz}$, $R_{FIL} = 100\text{k}$	●		± 1.0	± 3
	$V_S = \pm 5\text{V}$, $f_C = 25.6\text{kHz}$, $R_{FIL} = 100\text{k}$	●		± 1.5	± 3
DC Offset Voltage, LP Mode (Input to Output, Sections A, B Cascaded)	$V_S = 2.7\text{V}$, $f_C = 25.6\text{kHz}$, $R_{FIL} = 100\text{k}$	●		± 2	± 5
	$V_S = 4.75\text{V}$, $f_C = 25.6\text{kHz}$, $R_{FIL} = 100\text{k}$	●		± 2	± 5
	$V_S = \pm 5\text{V}$, $f_C = 25.6\text{kHz}$, $R_{FIL} = 100\text{k}$	●		± 2	± 6

ELECTRICAL CHARACTERISTICS

The ● denotes specifications which apply over the full operating temperature range, otherwise specifications are $T_A = 25^\circ\text{C}$.

$V_S = \text{Single } 4.75\text{V}$, $\overline{\text{EN}}$ pin to logic "low," Gain = 1, $R_{\text{FIL}} = R_{11} = R_{21} = R_{31} = R_{12} = R_{22} = R_{32}$, specifications apply to both the high speed (HS) and low power (LP) modes unless otherwise noted.

PARAMETER	CONDITIONS		MIN	TYP	MAX	UNITS
DC Offset Voltage Drift, HS Mode (Input to Output, Sections A, B)	$V_S = 3\text{V}$, $f_C = 25.6\text{kHz}$, $R_{\text{FIL}} = 100\text{k}$	●		5		$\mu\text{V}/^\circ\text{C}$
	$V_S = 4.75\text{V}$, $f_C = 25.6\text{kHz}$, $R_{\text{FIL}} = 100\text{k}$	●		5		$\mu\text{V}/^\circ\text{C}$
	$V_S = \pm 5\text{V}$, $f_C = 25.6\text{kHz}$, $R_{\text{FIL}} = 100\text{k}$	●		5		$\mu\text{V}/^\circ\text{C}$
DC Offset Voltage Drift, LP Mode (Input to Output, Sections A, B)	$V_S = 2.7\text{V}$, $f_C = 25.6\text{kHz}$, $R_{\text{FIL}} = 100\text{k}$	●		5		$\mu\text{V}/^\circ\text{C}$
	$V_S = 4.75\text{V}$, $f_C = 25.6\text{kHz}$, $R_{\text{FIL}} = 100\text{k}$	●		5		$\mu\text{V}/^\circ\text{C}$
	$V_S = \pm 5\text{V}$, $f_C = 25.6\text{kHz}$, $R_{\text{FIL}} = 100\text{k}$	●		5		$\mu\text{V}/^\circ\text{C}$
AGND Voltage	$V_S = 4.75\text{V}$, $f_C = 25.6\text{kHz}$, $R_{\text{FIL}} = 100\text{k}$	●	2.35	2.375	2.40	V
Power Supply Current, HS Mode	$V_S = 3\text{V}$, $f_C = 25.6\text{kHz}$, $R_{\text{FIL}} = 100\text{k}$	●		8.0	14	mA
	$V_S = 4.75\text{V}$, $f_C = 25.6\text{kHz}$, $R_{\text{FIL}} = 100\text{k}$	●		10.5	17	mA
	$V_S = \pm 5\text{V}$, $f_C = 25.6\text{kHz}$, $R_{\text{FIL}} = 100\text{k}$	●		15	23	mA
Power Supply Current, LP Mode	$V_S = 2.7\text{V}$, $f_C = 25.6\text{kHz}$, $R_{\text{FIL}} = 100\text{k}$	●		1.0	1.8	mA
	$V_S = 4.75\text{V}$, $f_C = 25.6\text{kHz}$, $R_{\text{FIL}} = 100\text{k}$	●		1.4	2.5	mA
	$V_S = \pm 5\text{V}$, $f_C = 25.6\text{kHz}$, $R_{\text{FIL}} = 100\text{k}$	●		2.3	3.5	mA
Shutdown Mode Supply Current	$V_S = 4.75\text{V}$, $f_C = 25.6\text{kHz}$, $R_{\text{FIL}} = 100\text{k}$	●		1	20	μA
$\overline{\text{EN}}$ Input Logic Low Level	$V_S = 3\text{V}$	●			0.8	V
	$V_S = 4.75\text{V}$	●			1	V
	$V_S = \pm 5\text{V}$	●			1	V
$\overline{\text{EN}}$ Input Logic High Level	$V_S = 3\text{V}$	●	2.5			V
	$V_S = 4.75\text{V}$	●	4.3			V
	$V_S = \pm 5\text{V}$	●	4.4			V
$\overline{\text{LP}}$ Logic Low Level	$V_S = 3\text{V}$	●			0.8	V
	$V_S = 4.75\text{V}$	●			1	V
	$V_S = \pm 5\text{V}$	●			1	V
$\overline{\text{LP}}$ Logic High Level	$V_S = 3\text{V}$	●	2.5			V
	$V_S = 4.75\text{V}$	●	4.3			V
	$V_S = \pm 5\text{V}$	●	4.4			V

LTC1563-2 Transfer Function Characteristics

Cutoff Frequency Range, f_C HS Mode	$V_S = 3\text{V}$	●	5		256	kHz
	$V_S = 4.75\text{V}$	●	5		256	kHz
	$V_S = \pm 5\text{V}$	●	5		256	kHz
Cutoff Frequency Range, f_C LP Mode	$V_S = 2.7\text{V}$	●	5		25.6	kHz
	$V_S = 4.75\text{V}$	●	5		25.6	kHz
	$V_S = \pm 5\text{V}$	●	5		25.6	kHz
Cutoff Frequency Accuracy, HS Mode $f_C = 25.6\text{kHz}$	$V_S = 3\text{V}$, $R_{\text{FIL}} = 100\text{k}$	●	-1.5	± 1.5	3.5	%
	$V_S = 4.75\text{V}$, $R_{\text{FIL}} = 100\text{k}$	●	-1.5	± 1.5	3.5	%
	$V_S = \pm 5\text{V}$, $R_{\text{FIL}} = 100\text{k}$	●	-1.5	± 1.5	3.5	%
Cutoff Frequency Accuracy, HS Mode $f_C = 256\text{kHz}$	$V_S = 3\text{V}$, $R_{\text{FIL}} = 10\text{k}$	●	-5	± 1.5	1.5	%
	$V_S = 4.75\text{V}$, $R_{\text{FIL}} = 10\text{k}$	●	-5	± 1.5	1.5	%
	$V_S = \pm 5\text{V}$, $R_{\text{FIL}} = 10\text{k}$	●	-5	± 1.5	1.5	%
Cutoff Frequency Accuracy, LP Mode $f_C = 25.6\text{kHz}$	$V_S = 2.7\text{V}$, $R_{\text{FIL}} = 100\text{k}$	●	-3	± 1.5	3	%
	$V_S = 4.75\text{V}$, $R_{\text{FIL}} = 100\text{k}$	●	-3	± 1.5	3	%
	$V_S = \pm 5\text{V}$, $R_{\text{FIL}} = 100\text{k}$	●	-3	± 1.5	3	%
Cutoff Frequency Temperature Coefficient		●		± 1		ppm/ $^\circ\text{C}$
Passband Gain, HS Mode, $f_C = 25.6\text{kHz}$ $V_S = 4.75\text{V}$, $R_{\text{FIL}} = 100\text{k}$	Test Frequency = 2.56kHz ($0.1 \cdot f_C$)	●	-0.2	0	0.2	dB
	Test Frequency = 12.8kHz ($0.5 \cdot f_C$)	●	-0.3	0	0.3	dB

LTC1563-2/LTC1563-3

ELECTRICAL CHARACTERISTICS

The ● denotes specifications which apply over the full operating temperature range, otherwise specifications are $T_A = 25^\circ\text{C}$.

$V_S = \text{Single } 4.75\text{V}$, $\overline{\text{EN}}$ pin to logic "low," Gain = 1, $R_{\text{FIL}} = R11 = R21 = R31 = R12 = R22 = R32$, specifications apply to both the high speed (HS) and low power (LP) modes unless otherwise noted.

PARAMETER	CONDITIONS		MIN	TYP	MAX	UNITS
Stopband Gain, HS Mode, $f_C = 25.6\text{kHz}$ $V_S = 4.75\text{V}$, $R_{\text{FIL}} = 100\text{k}$	Test Frequency = 51.2kHz ($2 \cdot f_C$)	●		-24	-21.5	dB
	Test Frequency = 102.4kHz ($4 \cdot f_C$)	●		-48	-46	dB
Passband Gain, HS Mode, $f_C = 256\text{kHz}$ $V_S = 4.75\text{V}$, $R_{\text{FIL}} = 10\text{k}$	Test Frequency = 25.6kHz ($0.1 \cdot f_C$)	●	-0.2	0	0.2	dB
	Test Frequency = 128kHz ($0.5 \cdot f_C$)	●	-0.5	0	0.5	dB
Stopband Gain, HS Mode, $f_C = 256\text{kHz}$ $V_S = 4.75\text{V}$, $R_{\text{FIL}} = 10\text{k}$	Test Frequency = 400kHz ($1.56 \cdot f_C$)	●		-15.7	-13.5	dB
	Test Frequency = 500kHz ($1.95 \cdot f_C$)	●		-23.3	-21.5	dB
Passband Gain, LP Mode, $f_C = 25.6\text{kHz}$ $V_S = 4.75\text{V}$, $R_{\text{FIL}} = 100\text{k}$	Test Frequency = 2.56kHz ($0.1 \cdot f_C$)	●	-0.25	0	0.25	dB
	Test Frequency = 12.8kHz ($0.5 \cdot f_C$)	●	-0.6	-0.02	0.6	dB
Stopband Gain, LP Mode, $f_C = 25.6\text{kHz}$ $V_S = 4.75\text{V}$, $R_{\text{FIL}} = 100\text{k}$	Test Frequency = 51.2kHz ($2 \cdot f_C$)	●		-24	-22	dB
	Test Frequency = 102.4kHz ($4 \cdot f_C$)	●		-48	-46.5	dB

LTC1563-3 Transfer Function Characteristics

Cutoff Frequency Range, f_C HS Mode	$V_S = 3\text{V}$	●	5		256	kHz
	$V_S = 4.75\text{V}$	●	5		256	kHz
	$V_S = \pm 5\text{V}$	●	5		256	kHz
Cutoff Frequency Range, f_C LP Mode	$V_S = 2.7\text{V}$	●	5		25.6	kHz
	$V_S = 4.75\text{V}$	●	5		25.6	kHz
	$V_S = \pm 5\text{V}$	●	5		25.6	kHz
Cutoff Frequency Accuracy, HS Mode $f_C = 25.6\text{kHz}$	$V_S = 3\text{V}$, $R_{\text{FIL}} = 100\text{k}$	●	-2	± 2	5.5	%
	$V_S = 4.75\text{V}$, $R_{\text{FIL}} = 100\text{k}$	●	-2	± 2	5.5	%
	$V_S = \pm 5\text{V}$, $R_{\text{FIL}} = 100\text{k}$	●	-2	± 2	5.5	%
Cutoff Frequency Accuracy, HS Mode $f_C = 256\text{kHz}$	$V_S = 3\text{V}$, $R_{\text{FIL}} = 10\text{k}$	●	-2	± 2	6	%
	$V_S = 4.75\text{V}$, $R_{\text{FIL}} = 10\text{k}$	●	-2	± 2	6	%
	$V_S = \pm 5\text{V}$, $R_{\text{FIL}} = 10\text{k}$	●	-2	± 2	6	%
Cutoff Frequency Accuracy, LP Mode $f_C = 25.6\text{kHz}$	$V_S = 2.7\text{V}$, $R_{\text{FIL}} = 100\text{k}$	●	-3	± 3	7	%
	$V_S = 4.75\text{V}$, $R_{\text{FIL}} = 100\text{k}$	●	-3	± 3	7	%
	$V_S = \pm 5\text{V}$, $R_{\text{FIL}} = 100\text{k}$	●	-3	± 3	7	%
Cutoff Frequency Temperature Coefficient		●		± 1		ppm/ $^\circ\text{C}$
Passband Gain, HS Mode, $f_C = 25.6\text{kHz}$ $V_S = 4.75\text{V}$, $R_{\text{FIL}} = 100\text{k}$	Test Frequency = 2.56kHz ($0.1 \cdot f_C$)	●	-0.2	-0.03	0.2	dB
	Test Frequency = 12.8kHz ($0.5 \cdot f_C$)	●	-1.0	-0.72	-0.25	dB
Stopband Gain, HS Mode, $f_C = 25.6\text{kHz}$ $V_S = 4.75\text{V}$, $R_{\text{FIL}} = 100\text{k}$	Test Frequency = 51.2kHz ($2 \cdot f_C$)	●		-13.6	-10	dB
	Test Frequency = 102.4kHz ($4 \cdot f_C$)	●		-34.7	-31	dB
Passband Gain, HS Mode, $f_C = 256\text{kHz}$ $V_S = 4.75\text{V}$, $R_{\text{FIL}} = 10\text{k}$	Test Frequency = 25.6kHz ($0.1 \cdot f_C$)	●	-0.2	-0.03	0.2	dB
	Test Frequency = 128kHz ($0.5 \cdot f_C$)	●	-1.1	-0.72	-0.5	dB
Stopband Gain, HS Mode, $f_C = 256\text{kHz}$ $V_S = 4.75\text{V}$, $R_{\text{FIL}} = 10\text{k}$	Test Frequency = 400kHz ($1.56 \cdot f_C$)	●		-8.3	-6	dB
	Test Frequency = 500kHz ($1.95 \cdot f_C$)	●		-13	-10.5	dB
Passband Gain, LP Mode, $f_C = 25.6\text{kHz}$ $V_S = 4.75\text{V}$, $R_{\text{FIL}} = 100\text{k}$	Test Frequency = 2.56kHz ($0.1 \cdot f_C$)	●	-0.2	-0.03	0.2	dB
	Test Frequency = 12.8kHz ($0.5 \cdot f_C$)	●	-1.0	-0.72	-0.25	dB
Stopband Gain, LP Mode, $f_C = 25.6\text{kHz}$ $V_S = 4.75\text{V}$, $R_{\text{FIL}} = 100\text{k}$	Test Frequency = 51.2kHz ($2 \cdot f_C$)	●		-13.6	-11	dB
	Test Frequency = 102.4kHz ($4 \cdot f_C$)	●		-34.7	-32	dB

Note 1: Absolute Maximum Ratings are those value beyond which the life of a device may be impaired.

PIN FUNCTIONS

$\overline{\text{LP}}$ (Pin 1): Low Power. The LTC1563-X has two operating modes. Most applications use the part's High Speed operating mode. Some lower frequency, lower gain applications can take advantage of the Low Power mode. When placed in the Low Power mode, the supply current is nearly an order of magnitude lower than the High Speed mode. Refer to the Applications Information section for more information on the Low Power mode.

The LTC1563-X is in the High Speed mode when the $\overline{\text{LP}}$ input is at a logic high level or is open-circuited. A small pull-up current source at the $\overline{\text{LP}}$ input defaults the LTC1563-X to the High Speed mode if the pin is left open. The part is in the Low Power mode when the pin is pulled to a logic low level or connected to V^- .

SA, SB (Pins 2, 11): Summing Pins. These pins are a summing point for signals fed forward and backward. Capacitance on the SA or SB pin will cause excess peaking of the frequency response near the cutoff frequency. The three external resistors for each section should be located as close as possible to the summing pin to minimize this effect. Refer to the Applications Information section for more details.

NC (Pins 3, 5, 10, 12, 14): These pins are not connected internally. For best performance, they should be connected to ground.

INVA, INVB (Pins 4, 13): Inverting Input. Each of the INV pins is an inverting input of an op amp. Note that the INV pins are high impedance, sensitive nodes of the filter and very susceptible to coupling of unintended signals. Capacitance on the INV nodes will also affect the frequency response of the filter sections. For these reasons, printed circuit connections to the INV pins must be kept as short as possible.

LPA, LPB (Pins 6, 15): Lowpass Output. These pins are the rail-to-rail outputs of an op amp. Each output is

designed to drive a nominal net load of $5\text{k}\Omega$ and 20pF . Refer to the Applications Information section for more details on output loading effects.

AGND (Pin 7): Analog Ground. The AGND pin is the midpoint of an internal resistive voltage divider developing a potential halfway between the V^+ and V^- pins. The equivalent series resistance is nominally $10\text{k}\Omega$. This serves as an internal ground reference. Filter performance will reflect the quality of the analog signal ground. An analog ground plane surrounding the package is recommended. The analog ground plane should be connected to any digital ground at a single point. Figures 1 and 2 show the proper connections for dual and single supply operation.

V^- , V^+ (Pins 8, 16): The V^- and V^+ pins should be bypassed with $0.1\mu\text{F}$ capacitors to an adequate analog ground or ground plane. These capacitors should be connected as closely as possible to the supply pins. Low noise linear supplies are recommended. Switching supplies are not recommended as they will decrease the filter's dynamic range. Refer to Figures 1 and 2 for the proper connections for dual and single supply operation.

$\overline{\text{EN}}$ (Pin 9): $\overline{\text{ENABLE}}$. When the $\overline{\text{EN}}$ input goes high or is open-circuited, the LTC1563-X enters a shutdown state and only junction leakage currents flow. The AGND pin, the LPA output and the LPB output assume high impedance states. If an input signal is applied to a complete filter circuit while the LTC1563-X is in shutdown, some signal will normally flow to the output through passive components around the inactive part.

A small internal pull-up current source at the $\overline{\text{EN}}$ input defaults the LTC1563 to the shutdown state if the $\overline{\text{EN}}$ pin is left floating. Therefore, the user *must* connect the $\overline{\text{EN}}$ pin to V^- (or a logic low) to enable the part for normal operation.

LTC1563-2/LTC1563-3

PIN FUNCTIONS

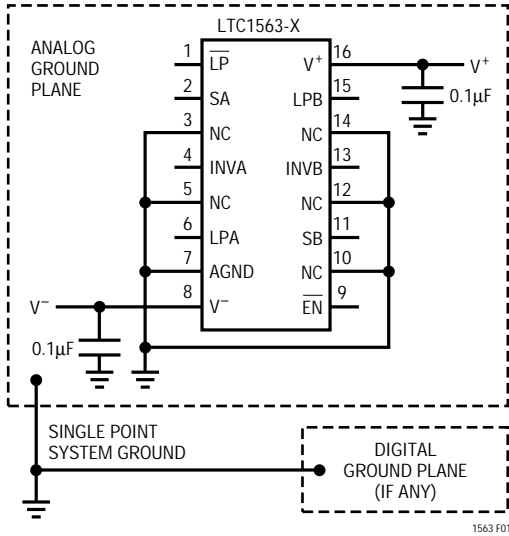

Figure 1. Dual Supply Power and Ground Connections

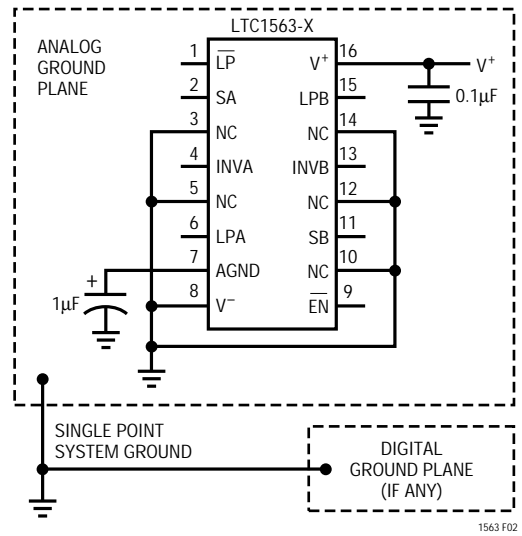
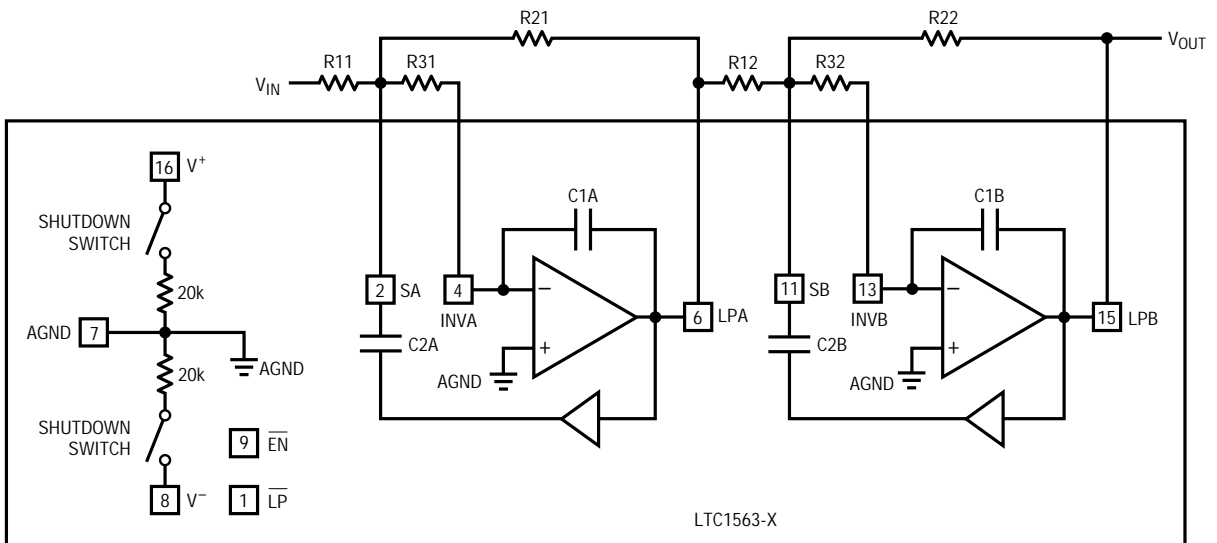

Figure 2. Single Supply Power and Ground Connections

BLOCK DIAGRAM



PATENT PENDING

1563 BD

APPLICATIONS INFORMATION

Functional Description

The LTC1563-2/LTC1563-3 are a family of easy-to-use, 4th order lowpass filters with rail-to-rail operation. The LTC1563-2, with a single resistor value, gives a unity-gain filter approximating a Butterworth response. The LTC1563-3, with a single resistor value, gives a unity-gain filter approximating a Bessel (linear phase) response. The proprietary architecture of these parts allows for a simple unity-gain resistor calculation:

$$R = 10k(256kHz/f_c)$$

where f_c is the desired cutoff frequency. For many applications, this formula is all that is needed to design a filter. For example, a 50kHz filter requires a 51.2k resistor. In practice, a 51.1k resistor would be used as this is the closest E96, 1% value available.

The LTC1563-X is constructed with two 2nd order sections. The output of the first section (section A) is simply fed into the second section (section B). Note that section A and section B are similar, but not identical. The parts are designed to be simple and easy to use.

By simply utilizing different valued resistors, gain and other transfer functions are achieved. For these applications, the resistor value calculation gets more difficult. The tables of formulas provided later in this section make this task much easier. For best results, design these filters using FilterCAD™ Version 3.0 (or newer) or contact the Linear Technology Filter Applications group for assistance.

Cutoff Frequency (f_c) and Gain limitations

The LTC563-X has both a maximum f_c limit and a minimum f_c limit. The maximum f_c limit (256kHz in High Speed mode and 25.6kHz in the Low Power mode) is set by the speed of the LTC1563-X's op amps. At the maximum f_c , the gain is also limited to unity.

A minimum f_c is dictated by the practical limitation of reliably obtaining large valued, precision resistors. As the desired f_c decreases, the resistor value required increases. When f_c is 2.56kHz, the resistors are 1M. Obtaining a reliable, precise 1M resistance between two points on a printed circuit board is somewhat difficult. For example, a 1M resistor with 20M Ω of stray, layout related resistance

in parallel, yields a net effective resistance of 952k and an error of –5%. Note that the gain is also limited to unity at the minimum f_c .

At intermediate f_c , the gain is limited by one of the two reasons discussed above. For best results, design filters with gain using FilterCAD Version 3 (or newer) or contact the Linear Technology Filter Applications Group for assistance.

DC Offset, Noise and Gain Considerations

The LTC1563-X is DC offset trimmed in a 2-step manner. First, section A is trimmed for minimum DC offset. Next, section B is trimmed to minimize the total DC offset (section A *plus* section B). This method is used to give the minimum DC offset in unity gain applications and most higher gain applications.

For gains greater than unity, the gain should be distributed such that most of the gain is taken in section A, with section B at a lower gain (preferably unity). This type of gain distribution results in the lowest noise and lowest DC offset. For high gain, low frequency applications, all of the gain is taken in section A, with section B set for unity-gain. In this configuration, the noise and DC offset is dominated by those of section A. At higher frequencies, the op amps' finite bandwidth limits the amount of gain that section A can reliably achieve. The gain is more evenly distributed in this case. The noise and DC offset of section A is now multiplied by the gain of section B. The result is slightly higher noise and offset.

Output Loading: Resistive and Capacitive

The op amps of the LTC1563-X have a rail-to-rail output stage. To obtain maximum performance, the output loading effects must be considered. Output loading issues can be divided into resistive effects and capacitive effects.

Resistive loading affects the maximum output signal swing and signal distortion. If the output load is excessive, the output swing is reduced and distortion is increased. All of the output voltage swing testing on the LTC1563-X is done with R22 = 100k and a 10k load resistor. For best undistorted output swing, the output load resistance should be greater than 10k.

APPLICATIONS INFORMATION

Capacitive loading on the output reduces the stability of the op amp. If the capacitive loading is sufficiently high, the stability margin is decreased to the point of oscillation at the output. Capacitive loading should be kept below 30pF. Good, tight layout techniques should be maintained at all times. These parts should not drive long traces and must never drive a long coaxial cable. *When probing the LTC1563-X, always use a 10x probe. Never use a 1x probe.* A standard 10x probe has a capacitance of 10pF to 15pF while a 1x probe's capacitance can be as high as 150pF. The use of a 1x probe will probably cause oscillation.

For larger capacitive loads, a series isolation resistor can be used between the part and the capacitive load. If the load is too great, a buffer must be used.

Layout Precautions

The LTC1563-X is an active RC filter. The response of the filter is determined by the on-chip capacitors and the external resistors. Any external, stray capacitance in parallel with an on-chip capacitor, or to an AC ground, can alter the transfer function.

Capacitance to an AC ground is the most likely problem. Capacitance on the LPA or LPB pins does not affect the transfer function but does affect the stability of the op amps. Capacitance on the INVA and INVB pins will affect the transfer function somewhat and will also affect the stability of the op amps. Capacitance on the SA and SB pins alters the transfer function of the filter. These pins are the most sensitive to stray capacitance. Stray capacitance on these pins results in peaking of the frequency response near the cutoff frequency. Poor layout can give 0.5dB to 1dB of excess peaking.

To minimize the effects of parasitic layout capacitance, all of the resistors for section A should be placed as close as possible to the SA pin. Place the R31 resistor first so that it is as close as possible to the SA pin on one end and as close as possible to the INVA pin on the other end. Use the same strategy for the layout of section B, keeping all of the resistors as close as possible to the SB node and first placing R32 between the SB and INVB pins. It is also best if the signal routing and resistors are on the same layer as the part without any vias in the signal path.

TYPICAL APPLICATIONS

4th Order Filter Responses Using the LTC1563-2

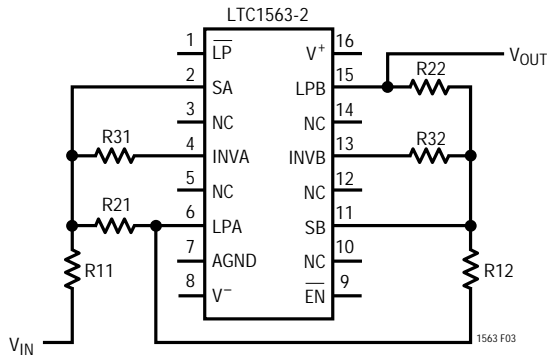

Figure 3. 4th Order Filter Connections (Power Supply, Ground, EN and LP Connections Not Shown for Clarity). Table 1 Shows Resistor Values

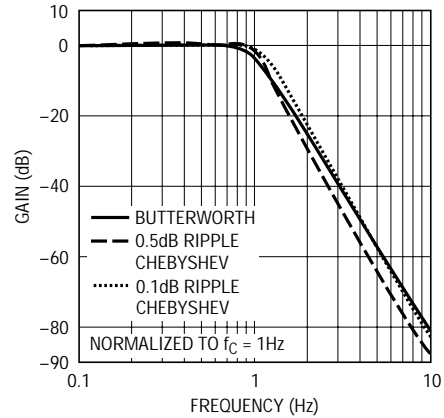

Figure 3a. Frequency Response

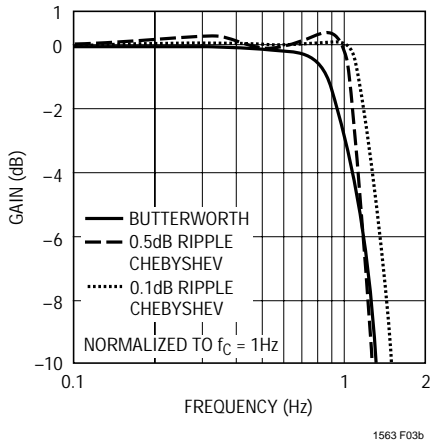

Figure 3b. Passband Frequency Response

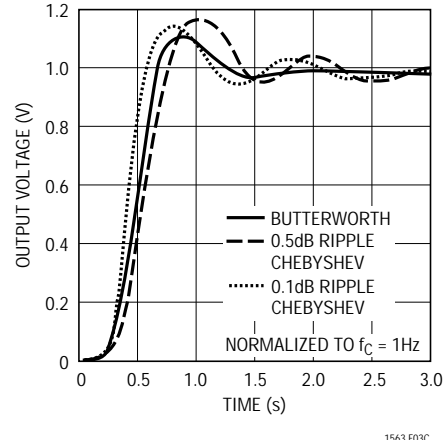

Figure 3c. Step Response

Table 1. Resistor Values, Normalized to 256kHz Cutoff Frequency (f_C), Figure 3. The Passband Gain, of the 4th Order LTC1563-2 Lowpass Filter, Is Set to Unity. (Note 1)

	BUTTERWORTH	0.1dB RIPPLE CHEBYSHEV	0.5dB RIPPLE CHEBYSHEV
LP Mode Max f_C	25.6kHz	15kHz	13kHz
HS Mode Max f_C	256kHz	135kHz	113kHz
R11 = R21 =	$10k(256kHz/f_C)$	$13.7k(256kHz/f_C)$	$20.5k(256kHz/f_C)$
R31 =	$10k(256kHz/f_C)$	$10.7k(256kHz/f_C)$	$12.4k(256kHz/f_C)$
R12 = R22 =	$10k(256kHz/f_C)$	$10k(256kHz/f_C)$	$12.1k(256kHz/f_C)$
R32 =	$10k(256kHz/f_C)$	$6.81k(256kHz/f_C)$	$6.98k(256kHz/f_C)$

Example: In HS mode, 0.1dB ripple Chebyshev, 100kHz cutoff frequency, R11 = R21 = 35k \cong 34.8k (1%), R31 = 27.39k \cong 27.4k (1%), R12 = R22 = 256k \cong 255k (1%), R32 = 17.43k \cong 17.4k (1%)

Note 1: The resistor values listed in this table provide good approximations of the listed transfer functions. For the optimal resistor values, higher gain or other transfer functions, use FilterCAD Version 3.0 (or newer) or contact the Linear Technology Filter Applications group for assistance.

LTC1563-2/LTC1563-3

TYPICAL APPLICATIONS

4th Order Filter Responses Using the LTC1563-3

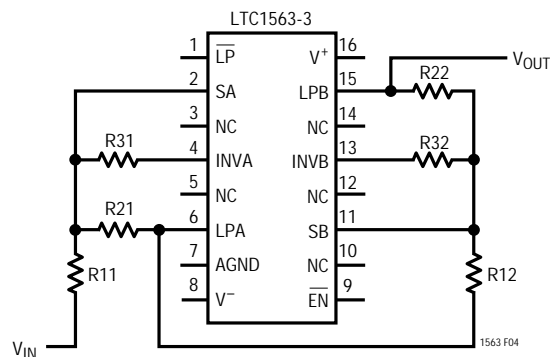

Figure 4. 4th Order Filter Connections (Power Supply, Ground, EN and LP Connections Not Shown for Clarity). Table 2 Shows Resistor Values

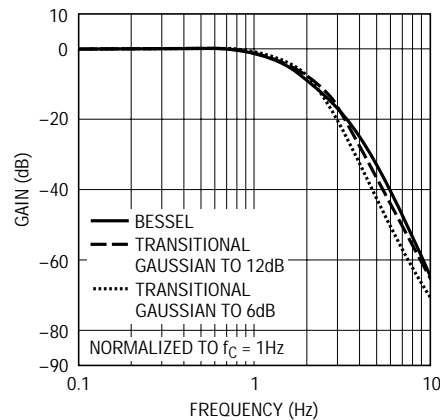

Figure 4a. Frequency Response

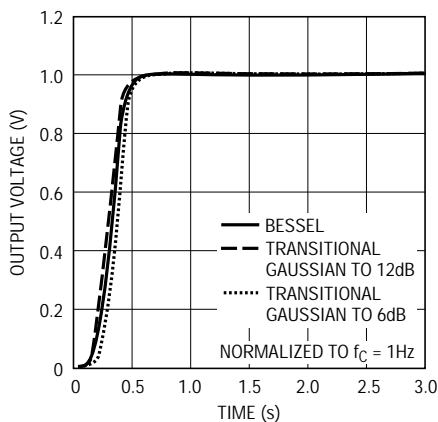

Figure 4b. Step Response

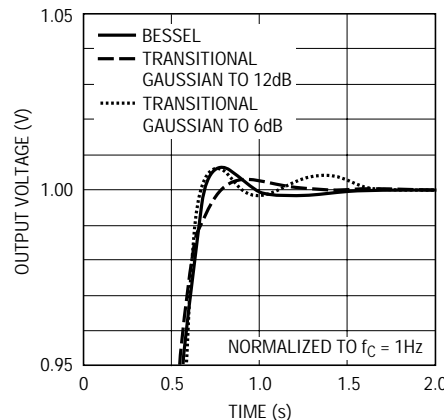

Figure 4c. Step Response—Settling

Table 2. Resistor Values, Normalized to 256kHz Cutoff Frequency (f_C), Figure 4. The Passband Gain, of the 4th Order LTC1563-3 Lowpass Filter, Is Set to Unity. (Note 1)

	BESSEL	TRANSITIONAL GAUSSIAN TO 6dB	TRANSITIONAL GAUSSIAN TO 12dB
LP Mode Max f_C	25.6kHz	20kHz	21kHz
HS Mode Max f_C	256kHz	175kHz	185kHz
R11 = R21 =	10k(256kHz/ f_C)	17.4k(256kHz/ f_C)	15k(256kHz/ f_C)
R31 =	10k(256kHz/ f_C)	13.3k(256kHz/ f_C)	11.8k(256kHz/ f_C)
R12 = R22 =	10k(256kHz/ f_C)	14.3k(256kHz/ f_C)	10.5k(256kHz/ f_C)
R32 =	10k(256kHz/ f_C)	6.04k(256kHz/ f_C)	6.19k(256kHz/ f_C)

Note 1: The resistor values listed in this table provide good approximations of the listed transfer functions. For the optimal resistor values, higher gain or other transfer functions, use FilterCAD Version 3.0 (or newer) or contact the Linear Technology Filter Applications group for assistance.

TYPICAL APPLICATIONS

$\pm 5V$, 2.3mA Supply Current, 20kHz, 4th Order, 0.5dB Ripple Chebyshev Lowpass Filter

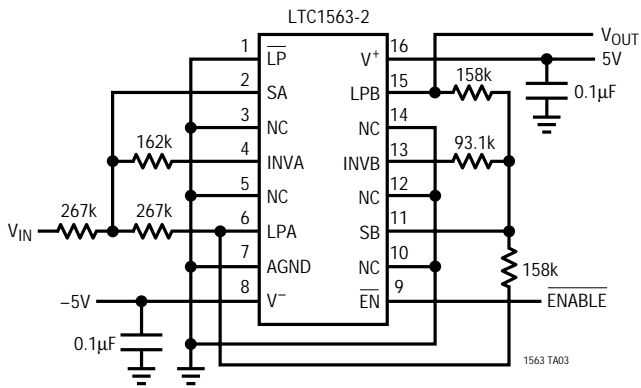

Frequency Response

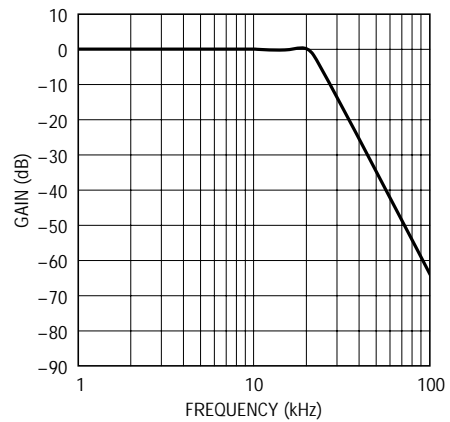

1563 TA04

Single 3.3V, 2mA Supply Current, 20kHz 8th Order Butterworth Lowpass Filter

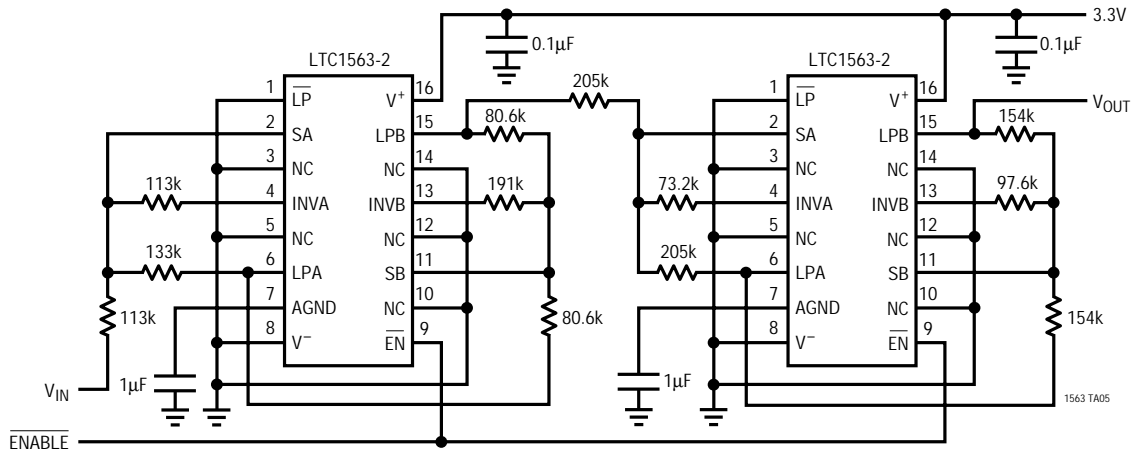

Frequency Response

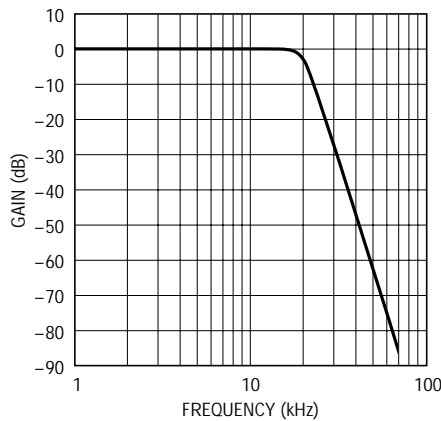

1563 TA06

LTC1563-2/LTC1563-3

TYPICAL APPLICATIONS

Single 3.3V, 256kHz Bessel Lowpass Filter

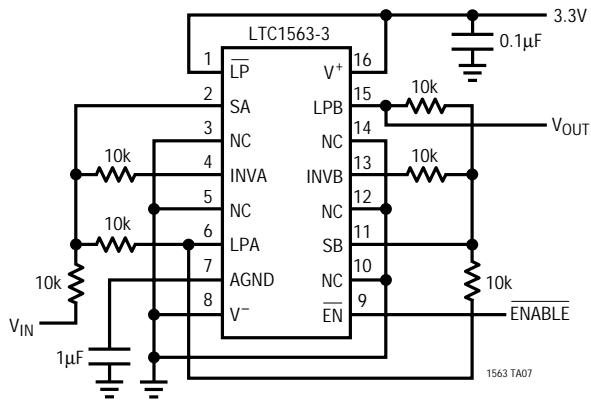

Frequency Response

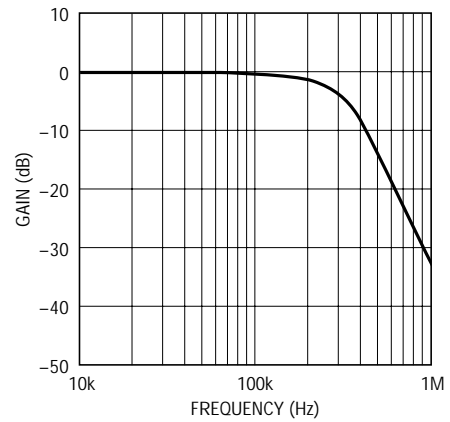

PACKAGE DESCRIPTION

GN Package
16-Lead Plastic SSOP (Narrow 0.150)
(LTC DWG # 05-08-1641)

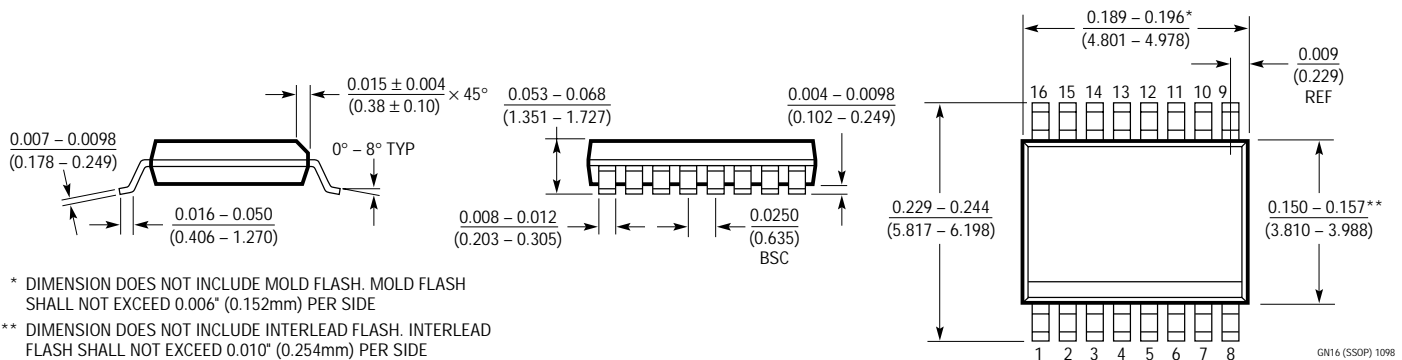

RELATED PARTS

PART NUMBER	DESCRIPTION	COMMENTS
LTC1560-1	5-Pole Elliptic Lowpass, $f_c = 1\text{MHz}/0.5\text{MHz}$	No External Components, SO-8
LTC1562	Universal Quad 2-Pole Active RC	$10\text{kHz} < f_0 < 150\text{kHz}$
LTC1562-2	Universal Quad 2-Pole Active RC	$20\text{kHz} < f_0 < 300\text{kHz}$
LTC1569-6	Low Power 10-Pole Delay Equalized Elliptic Lowpass	$f_c < 80\text{kHz}$, One Resistor Sets f_c , SO-8
LTC1569-7	10-Pole Delay Equalized Elliptic Lowpass	$f_c < 256\text{kHz}$, One Resistor Sets f_c , SO-8