

HIGH-VOLTAGE ADJUSTABLE REGULATOR

SLVS036E – SEPTEMBER 1981 – REVISED FEBRUARY 2000

- Output Adjustable From 1.25 V to 125 V When Used With an External Resistor Divider
- 700-mA Output Current
- Full Short-Circuit, Safe-Operating-Area, and Thermal-Shutdown Protection
- 0.001%/V Typical Input Voltage Regulation
- 0.15% Typical Output Voltage Regulation
- 76-dB Typical Ripple Rejection
- Standard TO-220AB Package

KC PACKAGE
(TOP VIEW)

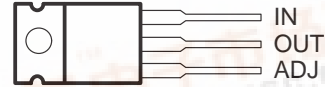

The OUT terminal is in electrical contact with the mounting base.

TO-220AB

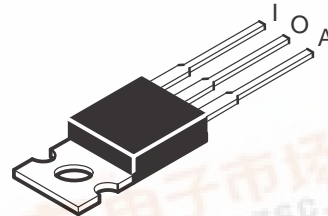

description

The TL783 is an adjustable three-terminal high-voltage regulator with an output range of 1.25 V to 125 V and a DMOS output transistor capable of sourcing more than 700 mA. It is designed for use in high-voltage applications where standard bipolar regulators cannot be used. Excellent performance specifications, superior to those of most bipolar regulators, are achieved through circuit design and advanced layout techniques.

As a state-of-the-art regulator, the TL783 combines standard bipolar circuitry with high-voltage double-diffused MOS transistors on one chip to yield a device capable of withstanding voltages far higher than standard bipolar integrated circuits. Because of its lack of secondary-breakdown and thermal-runaway characteristics usually associated with bipolar outputs, the TL783 maintains full overload protection while operating at up to 125 V from input to output. Other features of the device include current limiting, safe-operating-area (SOA) protection, and thermal shutdown. Even if ADJ is inadvertently disconnected, the protection circuitry remains functional.

Only two external resistors are required to program the output voltage. An input bypass capacitor is necessary only when the regulator is situated far from the input filter. An output capacitor, although not required, improves transient response and protection from instantaneous output short circuits. Excellent ripple rejection can be achieved without a bypass capacitor at the adjustment terminal.

The TL783C is characterized for operation over the virtual junction temperature range of 0°C to 125°C.

AVAILABLE OPTIONS

T _J	PACKAGED DEVICE	CHIP FORM (Y)
	HEAT-SINK MOUNTED (KC)	
0°C to 125°C	TL783CKC	TL783Y

Chip forms are tested at 25°C.

Please be aware that an important notice concerning availability, standard warranty, and use in critical applications of Texas Instruments semiconductor products and disclaimers thereto appears at the end of this data sheet.

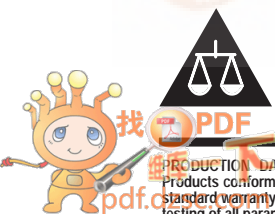

PRODUCTION DATA information is current as of publication date. Products conform to specifications per the terms of Texas Instruments standard warranty. Production processing does not necessarily include testing of all parameters.

TL783 HIGH-VOLTAGE ADJUSTABLE REGULATOR

SLVS036E – SEPTEMBER 1981 – REVISED FEBRUARY 2000

functional block diagram

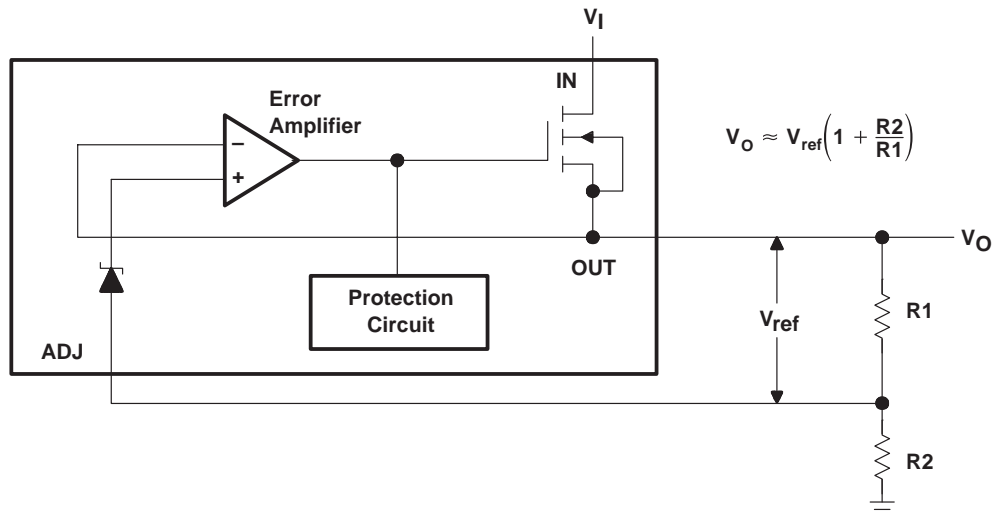

absolute maximum ratings over operating temperature range (unless otherwise noted)†

Input-to-output differential voltage, $V_I - V_O$	125 V
Operating free-air, T_A ; case, T_C ; or virtual junction, T_J , temperature	150°C
Package thermal impedance, θ_{JA} (see Notes 1 and 2)	22°C/W
Lead temperature 1,6 mm (1/16 inch) from case for 10 seconds	260°C
Storage temperature range, T_{stg}	-65°C to 150°C

† Stresses beyond those listed under “absolute maximum ratings” may cause permanent damage to the device. These are stress ratings only, and functional operation of the device at these or any other conditions beyond those indicated under “recommended operating conditions” is not implied. Exposure to absolute-maximum-rated conditions for extended periods may affect device reliability.

- NOTES: 1. Maximum power dissipation is a function of $T_J(\max)$, θ_{JA} , and T_A . The maximum allowable power dissipation at any allowable ambient temperature is $P_D = (T_J(\max) - T_A)/\theta_{JA}$. Operating at the absolute maximum T_J of 150°C can impact reliability. Due to variations in individual device electrical characteristics and thermal resistance, the built-in thermal overload protection may be activated at power levels slightly above or below the rated dissipation.
2. The package thermal impedance is calculated in accordance with JESD 51.

recommended operating conditions

	MIN	MAX	UNIT
Input-to-output voltage differential, $V_I - V_O$		125	V
Output current, I_O	15	700	mA
Operating virtual junction temperature, T_J		125	°C

TL783 HIGH-VOLTAGE ADJUSTABLE REGULATOR

SLVS036E – SEPTEMBER 1981 – REVISED FEBRUARY 2000

electrical characteristics at $V_I - V_O = 25\text{ V}$, $I_O = 0.5\text{ A}$, $T_J = 0^\circ\text{C}$ to 125°C (unless otherwise noted)

PARAMETER	TEST CONDITIONS†		TL783C			UNIT
			MIN	TYP	MAX	
Input voltage regulation‡	$V_I - V_O = 20\text{ V}$ to 125 V , $P \leq$ rated dissipation	$T_J = 25^\circ\text{C}$	0.001	0.01		%V
		$T_J = 0^\circ\text{C}$ to 125°C	0.004	0.02		
Ripple rejection	$\Delta V_I(\text{PP}) = 10\text{ V}$, $V_O = 10\text{ V}$, $f = 120\text{ Hz}$		66	76		dB
Output voltage regulation	$I_O = 15\text{ mA}$ to 700 mA , $T_J = 25^\circ\text{C}$	$V_O \leq 5\text{ V}$	7.5	25		mV
		$V_O \geq 5\text{ V}$	0.15%	0.5%		
	$I_O = 15\text{ mA}$ to 700 mA , $P \leq$ rated dissipation	$V_O \leq 5\text{ V}$	20	70		mV
		$V_O \geq 5\text{ V}$	0.3%	1.5%		
Output voltage change with temperature			0.4%			
Output voltage long-term drift	1000 hours at $T_J = 125^\circ\text{C}$, $V_I - V_O = 125\text{ V}$		0.2%			
Output noise voltage	$f = 10\text{ Hz}$ to 10 kHz , $T_J = 25^\circ\text{C}$		0.003%			
Minimum output current to maintain regulation	$V_I - V_O = 125\text{ V}$				15	mA
Peak output current	$V_I - V_O = 25\text{ V}$, $t = 1\text{ ms}$		1100			mA
	$V_I - V_O = 15\text{ V}$, $t = 30\text{ ms}$		715			
	$V_I - V_O = 25\text{ V}$, $t = 30\text{ ms}$		700	900		
	$V_I - V_O = 125\text{ V}$, $t = 30\text{ ms}$		100	250		
ADJ input current			83	110		μA
Change in ADJ input current	$V_I - V_O = 15\text{ V}$ to 125 V , $I_O = 15\text{ mA}$ to 700 mA , $P \leq$ rated dissipation		0.5	5		μA
Reference voltage (OUT to ADJ)	$V_I - V_O = 10\text{ V}$ to 125 V , $I_O = 15\text{ mA}$ to 700 mA , $P \leq$ rated dissipation, See Note 3		1.2	1.27	1.3	V

† Pulse-testing techniques maintain the junction temperature as close to the ambient temperature as possible. Thermal effects must be taken into account separately.

‡ Input voltage regulation is expressed here as the percentage change in output voltage per 1-V change at the input.

NOTE 3: Due to the dropout voltage and output current-limiting characteristics of this device, output current is limited to less than 700 mA at input-to-output voltage differentials of less than 25 V.

TL783 HIGH-VOLTAGE ADJUSTABLE REGULATOR

SLVS036E – SEPTEMBER 1981 – REVISED FEBRUARY 2000

electrical characteristics at $V_I - V_O = 25\text{ V}$, $I_O = 0.5\text{ A}$, $T_J = 25^\circ\text{C}$ (unless otherwise noted)

PARAMETER	TEST CONDITION†	TL783Y			UNIT
		MIN	TYP	MAX	
Input voltage regulation‡	$V_I - V_O = 20\text{ V to }125\text{ V}$, $P \leq \text{rated dissipation}$	0.001			%/V
Ripple rejection	$\Delta V_I(\text{PP}) = 10\text{ V}$, $V_O = 10\text{ V}$, $f = 120\text{ Hz}$	76			dB
Output voltage regulation	$I_O = 15\text{ mA to }700\text{ mA}$	$V_O \leq 5\text{ V}$	7.5		mV
		$V_O \geq 5\text{ V}$	0.15%		
	$I_O = 15\text{ mA to }700\text{ mA}$, $P \leq \text{rated dissipation}$	$V_O \leq 5\text{ V}$	20		mV
		$V_O \geq 5\text{ V}$	0.3%		
Output voltage change with temperature		0.4%			
Output noise voltage	$f = 10\text{ Hz to }10\text{ kHz}$	0.003%			
Peak output current	$V_I - V_O = 25\text{ V}$, $t = 1\text{ ms}$	1100			mA
	$V_I - V_O = 15\text{ V}$, $t = 30\text{ ms}$	715			
	$V_I - V_O = 25\text{ V}$, $t = 30\text{ ms}$	900			
	$V_I - V_O = 125\text{ V}$, $t = 30\text{ ms}$	250			
ADJ input current		83			μA
Change in ADJ input current	$V_I - V_O = 15\text{ V to }125\text{ V}$, $I_O = 15\text{ mA to }700\text{ mA}$, $P \leq \text{rated dissipation}$	0.5			μA
Reference voltage (OUT to ADJ)	$V_I - V_O = 10\text{ V to }125\text{ V}$, $I_O = 15\text{ mA to }700\text{ mA}$, $P \leq \text{rated dissipation}$, See Note 3	1.27			V

† Pulse-testing techniques maintain the junction temperature as close to the ambient temperature as possible. Thermal effects must be taken into account separately.

‡ Input voltage regulation is expressed here as the percentage change in output voltage per 1-V change at the input.

NOTE 3: Due to the dropout voltage and output current-limiting characteristics of this device, output current is limited to less than 700 mA at input-to-output voltage differentials of less than 25 V.

TL783 HIGH-VOLTAGE ADJUSTABLE REGULATOR

SLVS036E – SEPTEMBER 1981 – REVISED FEBRUARY 2000

TYPICAL CHARACTERISTICS

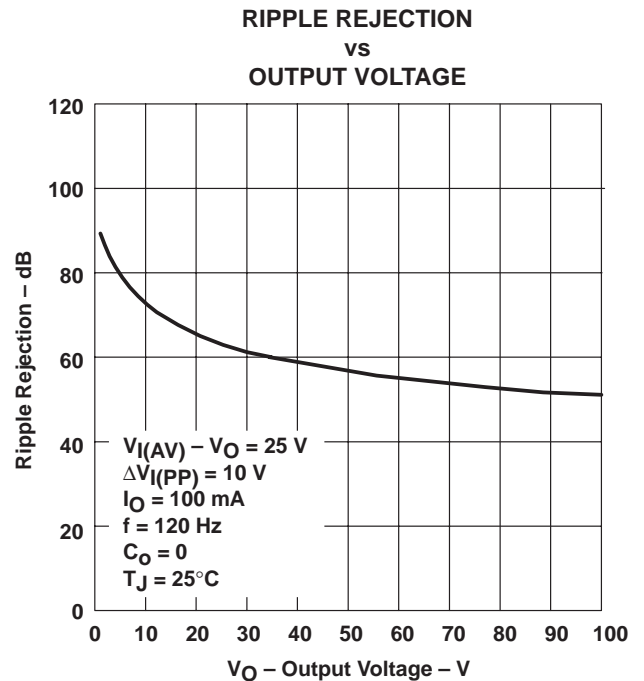
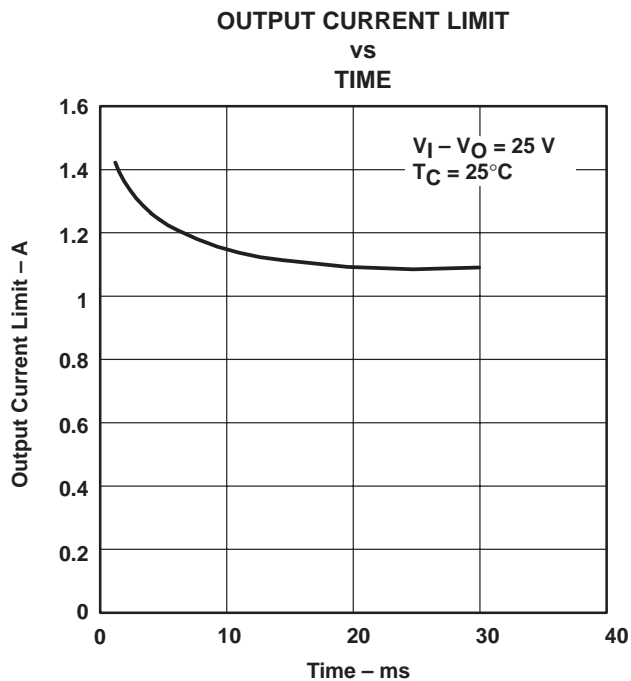
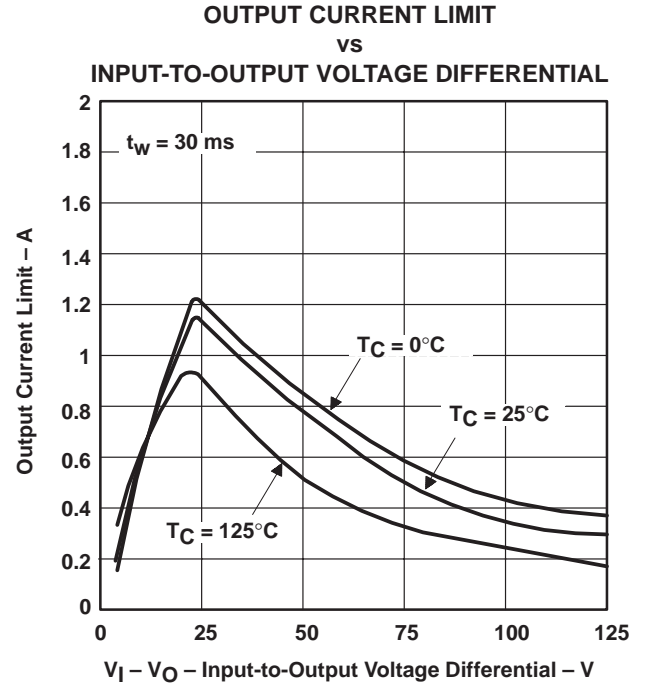
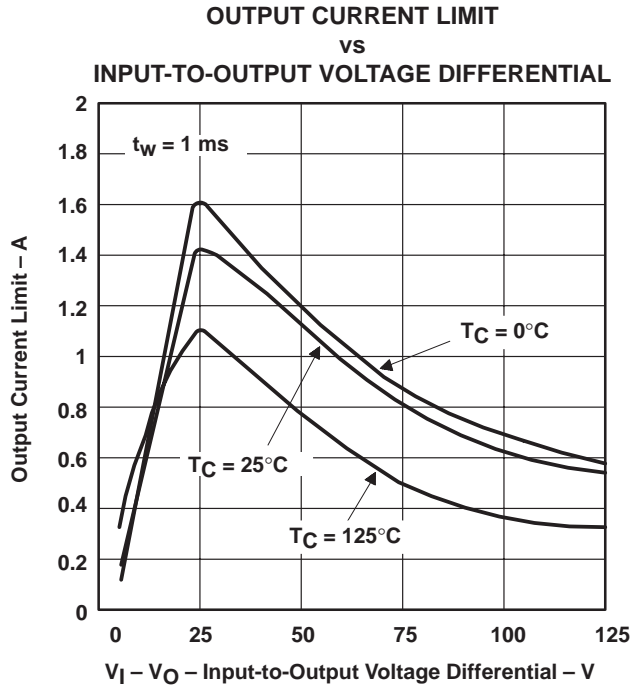

TL783 HIGH-VOLTAGE ADJUSTABLE REGULATOR

SLVS036E – SEPTEMBER 1981 – REVISED FEBRUARY 2000

TYPICAL CHARACTERISTICS†

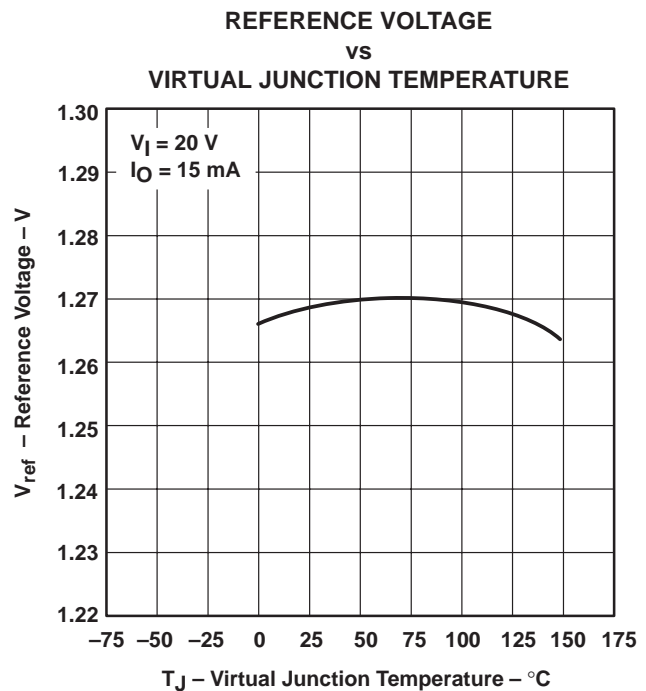
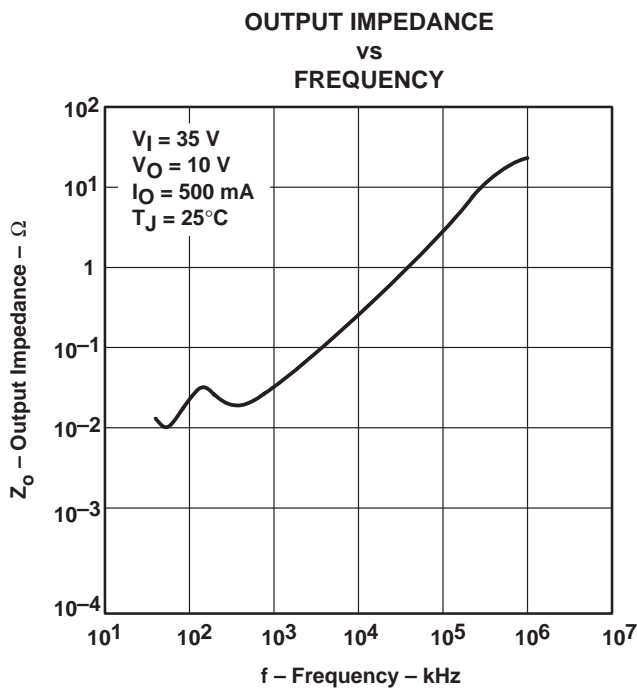
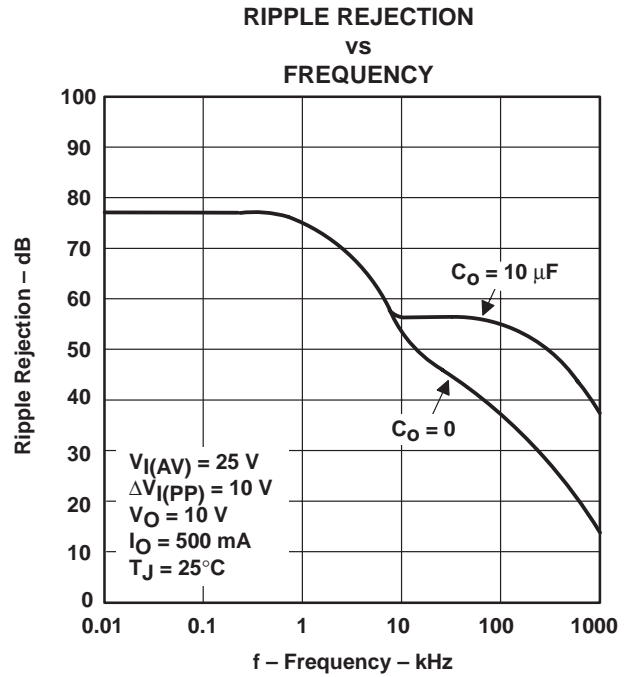
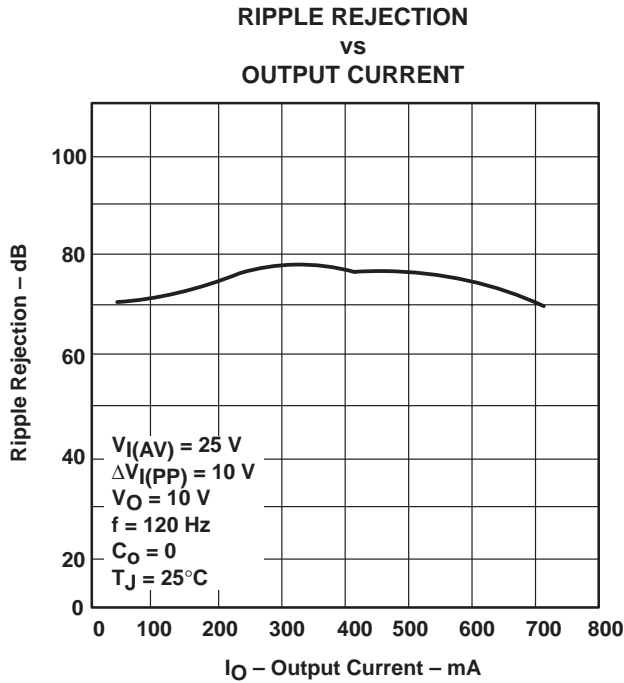

† Data at high and low temperatures are applicable only within the recommended operating free-air temperature ranges of the various devices.

TYPICAL CHARACTERISTICS

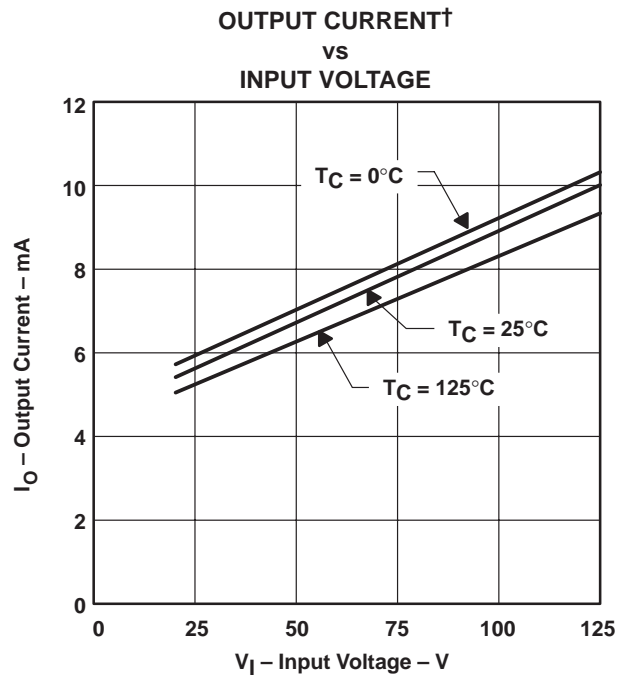
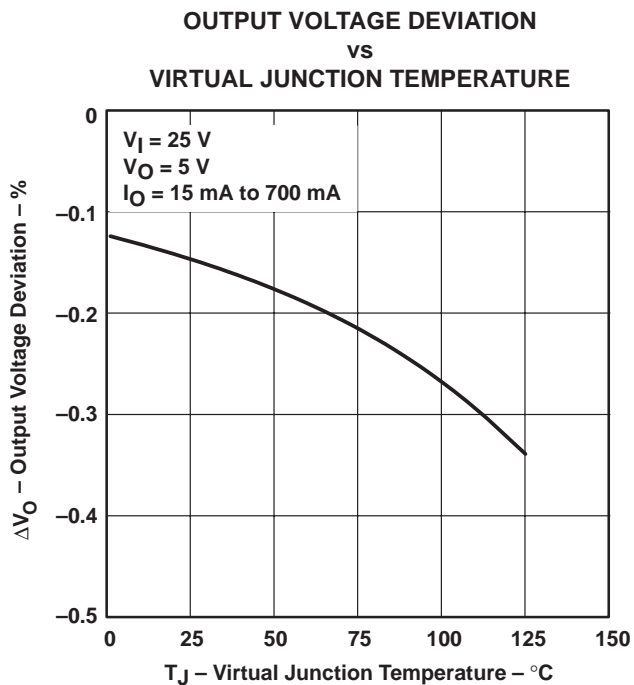
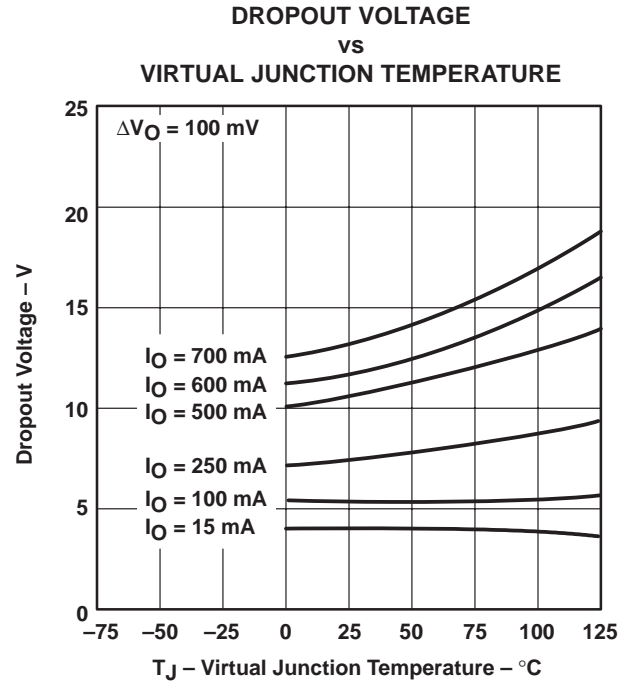
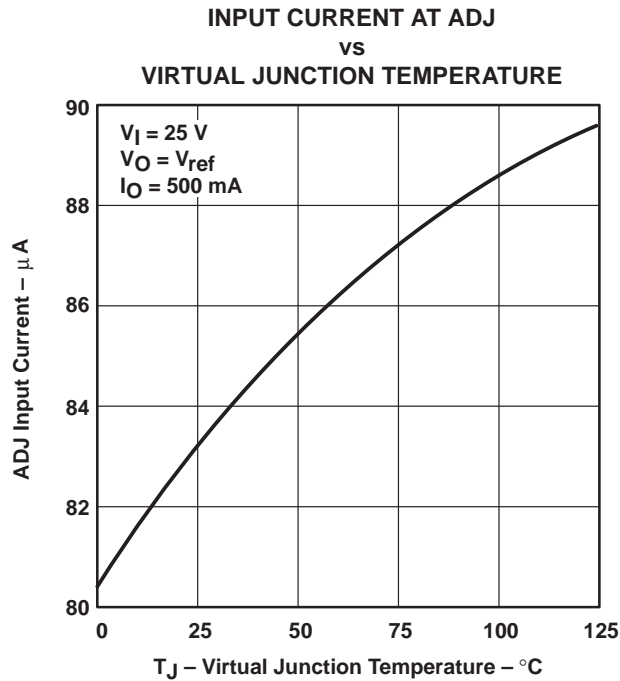

† This is the minimum current required to maintain voltage regulation.

TL783 HIGH-VOLTAGE ADJUSTABLE REGULATOR

SLVS036E – SEPTEMBER 1981 – REVISED FEBRUARY 2000

TYPICAL CHARACTERISTICS

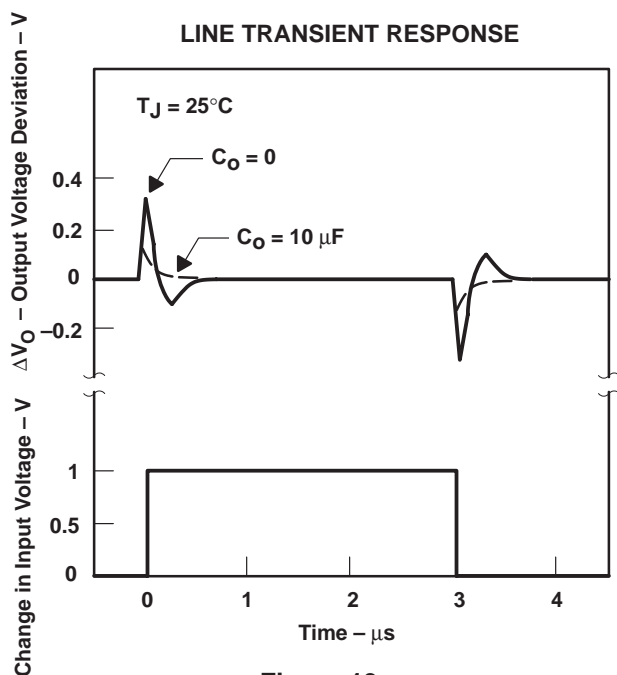

Figure 13

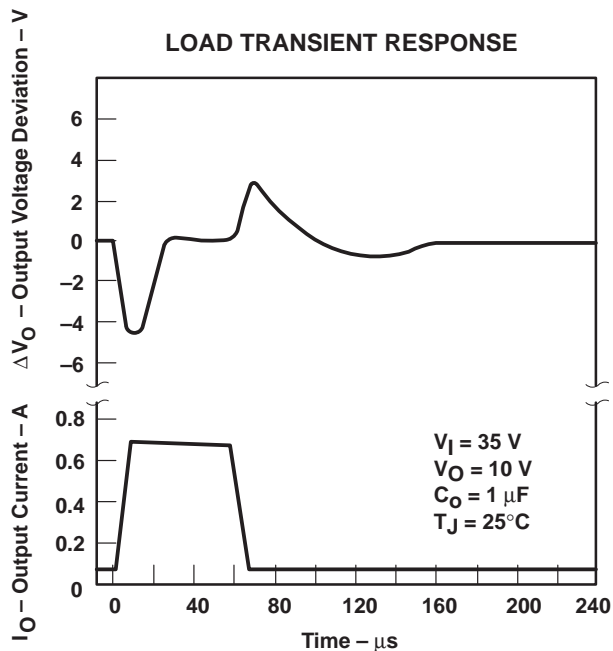

Figure 14

DESIGN CONSIDERATIONS

The internal reference (see functional block diagram) generates 1.25 V nominal (V_{ref}) between OUT and ADJ. This voltage is developed across R1 and causes a constant current to flow through R1 and the programming resistor R2, giving an output voltage of:

$$V_O = V_{\text{ref}} (1 + R_2/R_1) + I_{I(\text{ADJ})} (R_2)$$

or

$$V_O \approx V_{\text{ref}} (1 + R_2/R_1)$$

The TL783 was designed to minimize the input current at ADJ and maintain consistency over line and load variations, thereby minimizing the associated (R_2) error term.

To maintain $I_{I(\text{ADJ})}$ at a low level, all quiescent operating current is returned to the output terminal. This quiescent current must be sunk by the external load and is the minimum load current necessary to prevent the output from rising. The recommended R1 value of 82 Ω provides a minimum load current of 15 mA. Larger values can be used when the input-to-output differential voltage is less than 125 V (see the output-current curve in Figure 14) or when the load sinks some portion of the minimum current.

DESIGN CONSIDERATIONS

bypass capacitors

The TL783 regulator is stable without bypass capacitors; however, any regulator becomes unstable with certain values of output capacitance if an input capacitor is not used. Therefore, the use of input bypassing is recommended whenever the regulator is located more than four inches from the power-supply filter capacitor. A 1- μ F tantalum or aluminum electrolytic capacitor usually is sufficient.

Adjustment-terminal capacitors are not recommended for use on the TL783 because they can seriously degrade load transient response as well as create a need for extra protection circuitry. Excellent ripple rejection presently is achieved without this added capacitor.

Due to the relatively low gain of the MOS output stage, output voltage dropout may occur under large load transient conditions. The addition of an output bypass capacitor greatly enhances load transient response and prevents dropout. For most applications, it is recommended that an output bypass capacitor be used, with a minimum value of:

$$C_o (\mu\text{F}) = 15/V_o$$

Larger values provide proportionally better transient-response characteristics.

protection circuitry

The TL783 regulator includes built-in protection circuits capable of guarding the device against most overload conditions encountered in normal operation. These protective features are current limiting, safe-operating-area protection, and thermal shutdown. These circuits protect the device under occasional fault conditions only. Continuous operation in the current limit or thermal shutdown mode is not recommended.

The internal protection circuits of the TL783 protect the device up to maximum-rated V_I as long as certain precautions are taken. If V_I is instantaneously switched on, transients exceeding maximum input ratings may occur, which can destroy the regulator. These are usually caused by lead inductance and bypass capacitors causing a ringing voltage on the input. In addition, when rise times in excess of 10 V/ns are applied to the input, a parasitic npn transistor in parallel with the DMOS output can be turned on, causing the device to fail. If the device is operated over 50 V and the input is switched on rather than ramped on, a low-Q capacitor, such as tantalum or aluminum electrolytic should be used rather than ceramic, paper, or plastic bypass capacitors. A Q factor of 0.015 or greater usually provides adequate damping to suppress ringing. Normally, no problems occur if the input voltage is allowed to ramp upward through the action of an ac line rectifier and filter network.

Similarly, when an instantaneous short circuit is applied to the output, both ringing and excessive fall times can result. A tantalum or aluminum electrolytic bypass capacitor is recommended to eliminate this problem. However, if a large output capacitor is used and the input is shorted, addition of a protection diode may be necessary to prevent capacitor discharge through the regulator. The amount of discharge current delivered is dependent on output voltage, size of capacitor, and fall time of V_I . A protective diode (see Figure 17) is required only for capacitance values greater than:

$$C_o (\mu\text{F}) = 3 \times 10^4 / (V_o)^2$$

Care always should be taken to prevent insertion of regulators into a socket with power on. Power should be turned off before removing or inserting regulators.

TL783 HIGH-VOLTAGE ADJUSTABLE REGULATOR

SLVS036E – SEPTEMBER 1981 – REVISED FEBRUARY 2000

DESIGN CONSIDERATIONS

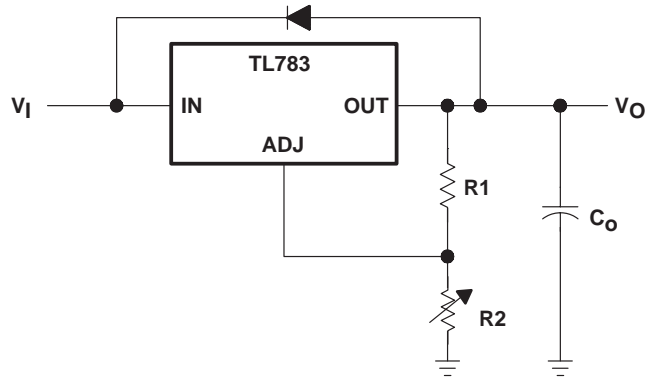

Figure 15. Regulator With Protective Diode

load regulation

The current-set resistor (R1) should be located close to the regulator output terminal rather than near the load. This eliminates long line drops from being amplified, through the action of R1 and R2, to degrade load regulation. To provide remote ground sensing, R2 should be near the load ground.

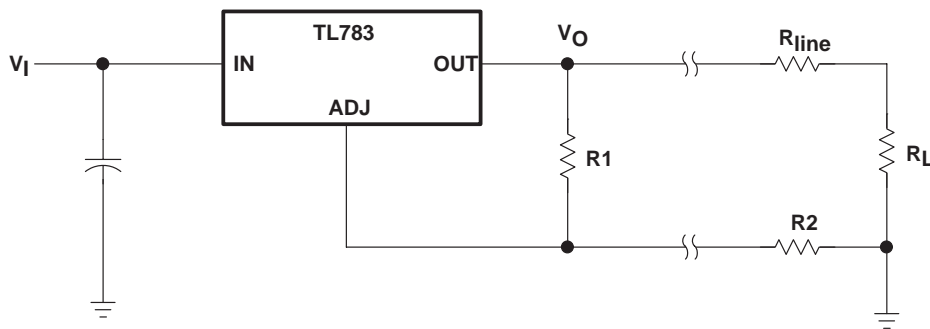
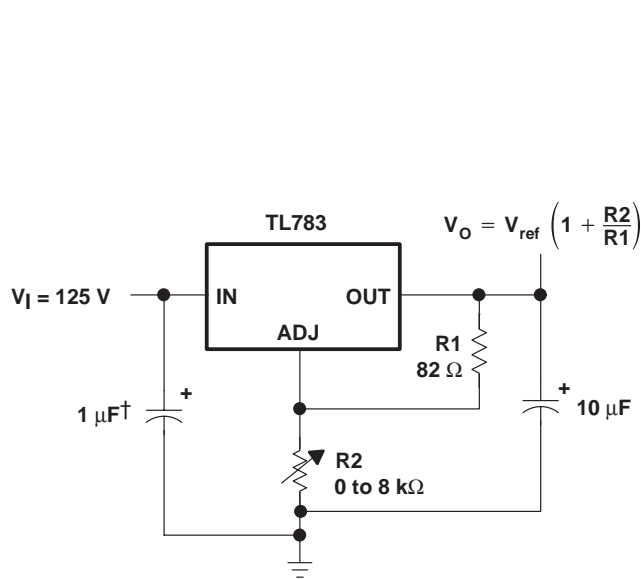

Figure 16. Regulator With Current-Set Resistor

TL783 HIGH-VOLTAGE ADJUSTABLE REGULATOR

SLVS036E – SEPTEMBER 1981 – REVISED FEBRUARY 2000

APPLICATION INFORMATION



† Needed if device is more than 4 inches from filter capacitor

Figure 17. 1.25-V to 115-V Adjustable Regulator

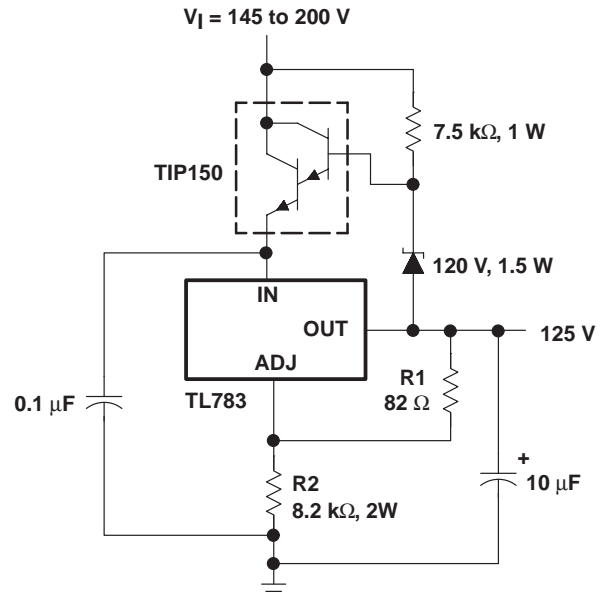

Figure 18. 125-V Short-Circuit-Protected Off-Line Regulator

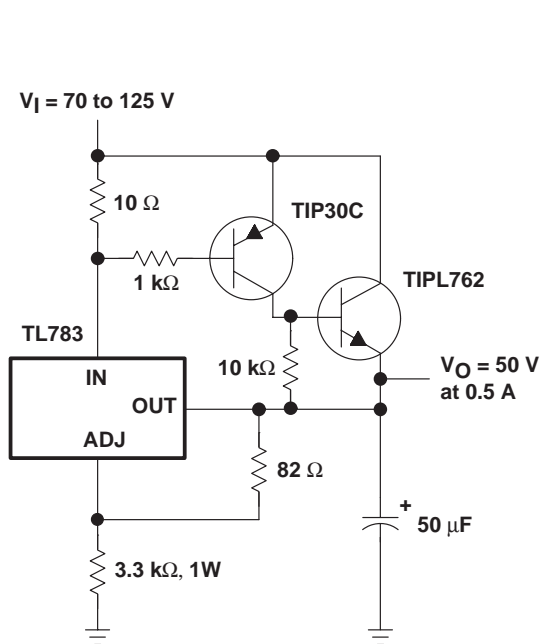

Figure 19. 50-V Regulator With Current Boost

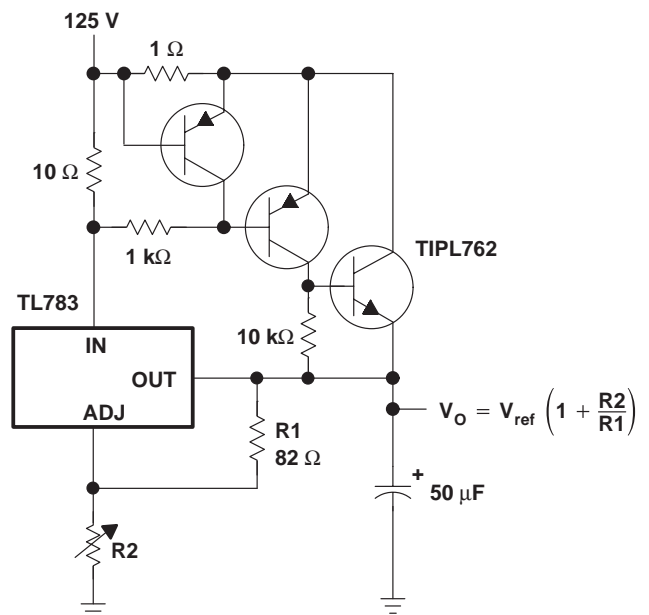

Figure 20. Adjustable Regulator With Current Boost and Current Limit

TL783 HIGH-VOLTAGE ADJUSTABLE REGULATOR

SLVS036E – SEPTEMBER 1981 – REVISED FEBRUARY 2000

APPLICATION INFORMATION

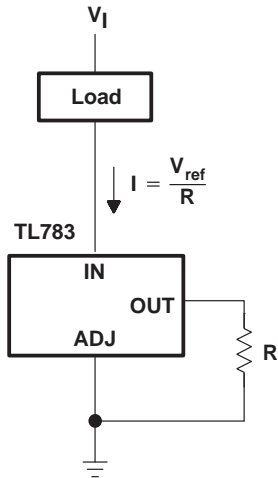

Figure 21. Current-Sinking Regulator

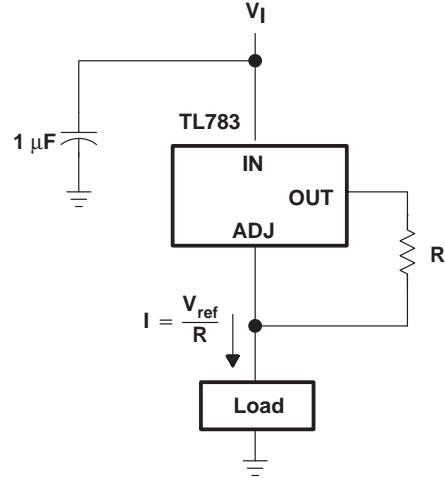

Figure 22. Current-Sourcing Regulator

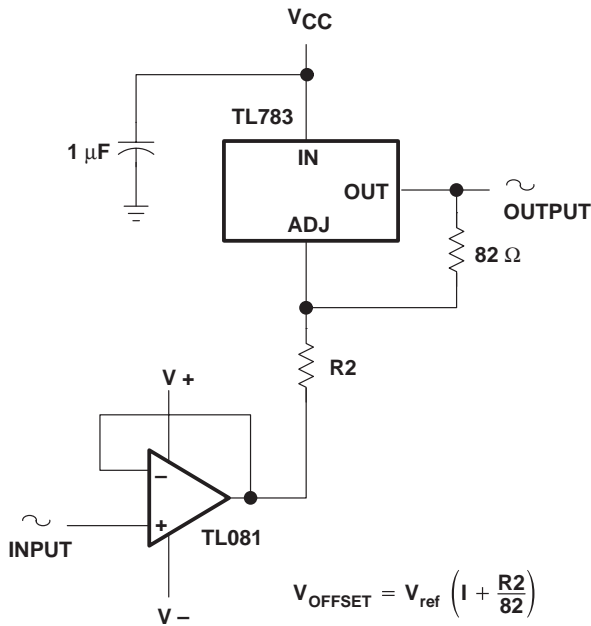

Figure 23. High-Voltage Unity-Gain Offset Amplifier

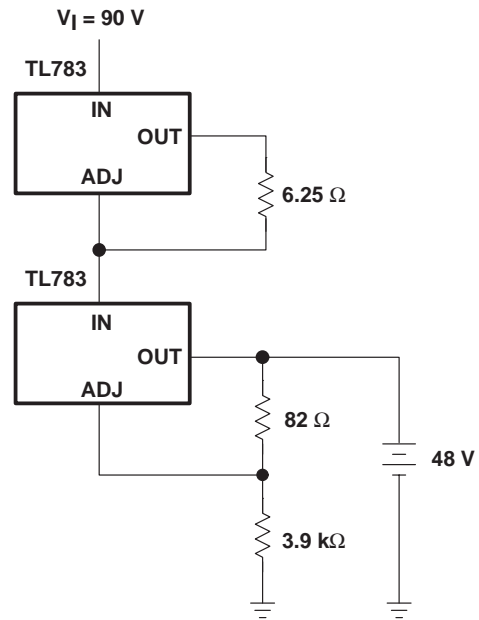

Figure 24. 48-V, 200-mA Float Charger

IMPORTANT NOTICE

Texas Instruments and its subsidiaries (TI) reserve the right to make changes to their products or to discontinue any product or service without notice, and advise customers to obtain the latest version of relevant information to verify, before placing orders, that information being relied on is current and complete. All products are sold subject to the terms and conditions of sale supplied at the time of order acknowledgement, including those pertaining to warranty, patent infringement, and limitation of liability.

TI warrants performance of its semiconductor products to the specifications applicable at the time of sale in accordance with TI's standard warranty. Testing and other quality control techniques are utilized to the extent TI deems necessary to support this warranty. Specific testing of all parameters of each device is not necessarily performed, except those mandated by government requirements.

CERTAIN APPLICATIONS USING SEMICONDUCTOR PRODUCTS MAY INVOLVE POTENTIAL RISKS OF DEATH, PERSONAL INJURY, OR SEVERE PROPERTY OR ENVIRONMENTAL DAMAGE ("CRITICAL APPLICATIONS"). TI SEMICONDUCTOR PRODUCTS ARE NOT DESIGNED, AUTHORIZED, OR WARRANTED TO BE SUITABLE FOR USE IN LIFE-SUPPORT DEVICES OR SYSTEMS OR OTHER CRITICAL APPLICATIONS. INCLUSION OF TI PRODUCTS IN SUCH APPLICATIONS IS UNDERSTOOD TO BE FULLY AT THE CUSTOMER'S RISK.

In order to minimize risks associated with the customer's applications, adequate design and operating safeguards must be provided by the customer to minimize inherent or procedural hazards.

TI assumes no liability for applications assistance or customer product design. TI does not warrant or represent that any license, either express or implied, is granted under any patent right, copyright, mask work right, or other intellectual property right of TI covering or relating to any combination, machine, or process in which such semiconductor products or services might be or are used. TI's publication of information regarding any third party's products or services does not constitute TI's approval, warranty or endorsement thereof.