



# LT1933

## 600mA, 500kHz Step-Down Switching Regulator in SOT-23

### FEATURES

- **Wide Input Range: 3.6V to 36V**
- 5V at 600mA from 16V to 36V Input
- 3.3V at 600mA from 12V to 36V Input
- 5V at 500mA from 6.3V to 36V Input
- 3.3V at 500mA from 4.5V to 36V Input
- Fixed Frequency 500kHz Operation
- Uses Tiny Capacitors and Inductors
- Soft-Start
- Internally Compensated
- Low Shutdown Current:  $<2\mu\text{A}$
- Output Adjustable Down to 1.25V
- Low Profile (1mm) SOT-23 (ThinSOT™) Package

### APPLICATIONS

- Automotive Battery Regulation
- Industrial Control Supplies
- Wall Transformer Regulation
- Distributed Supply Regulation
- Battery-Powered Equipment

### DESCRIPTION

The LT<sup>®</sup>1933 is a current mode PWM step-down DC/DC converter with an internal 0.75A power switch, packaged in a tiny 6-lead SOT-23. The wide input range of 3.6V to 36V makes the LT1933 suitable for regulating power from a wide variety of sources, including unregulated wall transformers, 24V industrial supplies and automotive batteries. Its high operating frequency allows the use of tiny, low cost inductors and ceramic capacitors, resulting in low, predictable output ripple.

Cycle-by-cycle current limit provides protection against shorted outputs, and soft-start eliminates input current surge during start up. The low current ( $<2\mu\text{A}$ ) shutdown provides output disconnect, enabling easy power management in battery-powered systems.

LT, LTC and LT are registered trademarks of Linear Technology Corporation. ThinSOT is a trademark of Linear Technology Corporation.

### TYPICAL APPLICATION

3.3V Step-Down Converter

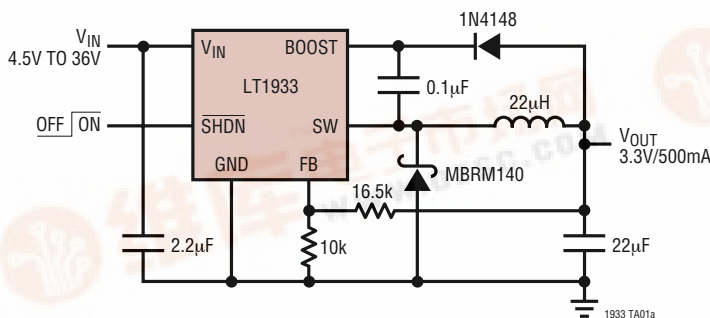

Efficiency

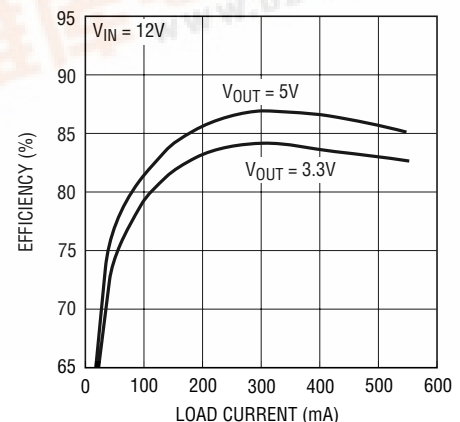

# LT1933

## ABSOLUTE MAXIMUM RATINGS

(Note 1)

Input Voltage ( $V_{IN}$ )	-0.4V to 36V
BOOST Pin Voltage	43V
BOOST Pin Above SW Pin	20V
SHDN Pin	-0.4V to 36V
FB Voltage	-0.4V to 6V
Operating Temperature Range (Note 2)	
LT1933E	-40°C to 85°C
LT1933I	-40°C to 125°C
Maximum Junction Temperature	125°C
Storage Temperature Range	-65°C to 150°C
Lead Temperature (Soldering, 10 sec)	300°C

## PACKAGE/ORDER INFORMATION

	ORDER PART NUMBER
	LT1933ES6 LT1933IS6
	S6 PART MARKING
	LTAGN LTAGP

Consult factory for parts specified with wider operating temperature ranges.

## ELECTRICAL CHARACTERISTICS

The ● denotes specifications which apply over the full operating temperature range, otherwise specifications are at  $T_A = 25^\circ\text{C}$ .  $V_{IN} = 12\text{V}$ ,  $V_{BOOST} = 17\text{V}$ , unless otherwise noted. (Note 2)

PARAMETER	CONDITIONS	MIN	TYP	MAX	UNITS
Undervoltage Lockout			3.35	3.6	V
Feedback Voltage		● 1.225	1.245	1.265	V
FB Pin Bias Current	$V_{FB} = \text{Measured } V_{REF} + 10\text{mV}$ (Note 4)	●	40	120	nA
Quiescent Current	Not Switching		1.6	2.5	mA
Quiescent Current in Shutdown	$V_{SHDN} = 0\text{V}$		0.01	2	$\mu\text{A}$
Reference Line Regulation	$V_{IN} = 5\text{V to } 36\text{V}$		0.01		%/V
Switching Frequency	$V_{FB} = 1.1\text{V}$	400	500	600	kHz
	$V_{FB} = 0\text{V}$		55		kHz
Maximum Duty Cycle		● 88	94		%
Switch Current Limit	(Note 3)	0.75	1.05		A
Switch $V_{CESAT}$	$I_{SW} = 400\text{mA}$		370	500	mV
Switch Leakage Current				2	$\mu\text{A}$
Minimum Boost Voltage Above Switch	$I_{SW} = 400\text{mA}$		1.9	2.3	V
BOOST Pin Current	$I_{SW} = 400\text{mA}$		18	25	mA
SHDN Input Voltage High		2.3			V
SHDN Input Voltage Low				0.3	V
SHDN Bias Current	$V_{SHDN} = 2.3\text{V}$ (Note 5)		34	50	$\mu\text{A}$
	$V_{SHDN} = 0\text{V}$		0.01	0.1	$\mu\text{A}$

**Note 1:** Absolute Maximum Ratings are those values beyond which the life of the device may be impaired.

**Note 2:** The LT1933E is guaranteed to meet performance specifications from 0°C to 70°C. Specifications over the -40°C to 85°C operating temperature range are assured by design, characterization and correlation

with statistical process controls. The LT1933I specifications are guaranteed over the -40°C to 125°C temperature range.

**Note 3:** Current limit guaranteed by design and/or correlation to static test. Slope compensation reduces current limit at higher duty cycle.

**Note 4:** Current flows out of pin.

**Note 5:** Current flows into pin.

# TYPICAL PERFORMANCE CHARACTERISTICS

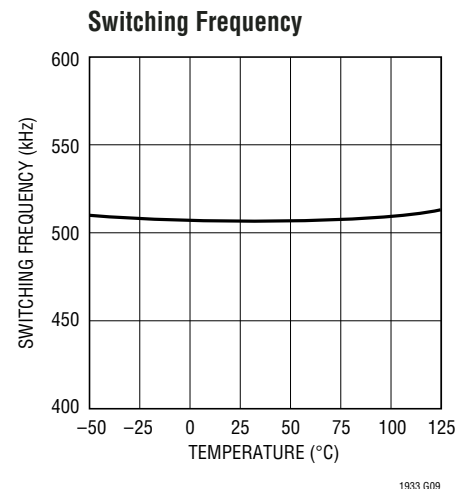
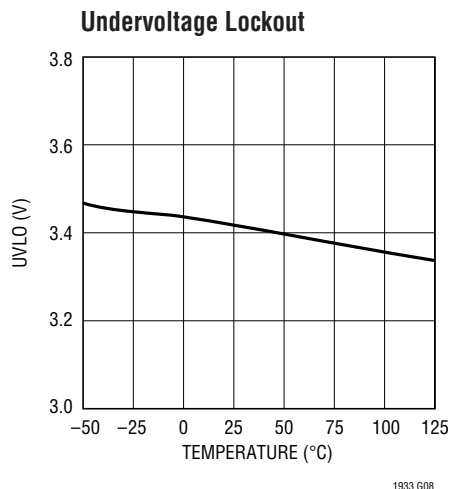
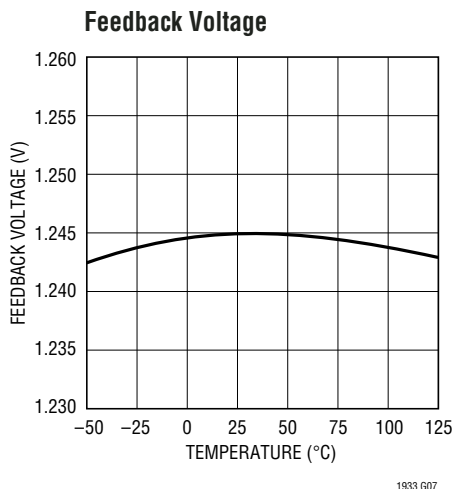
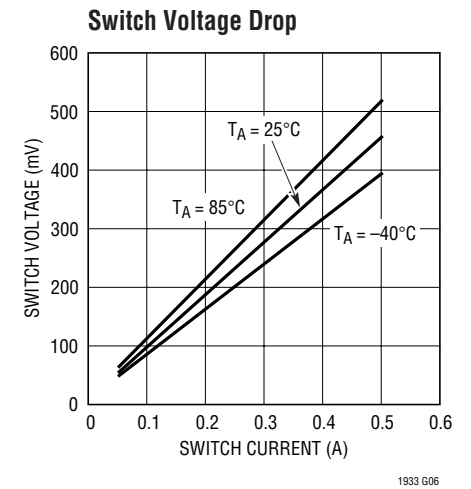
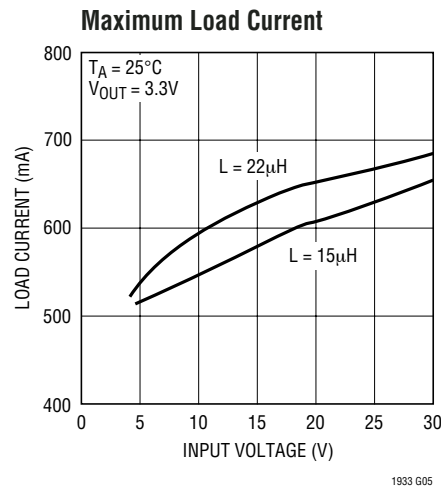
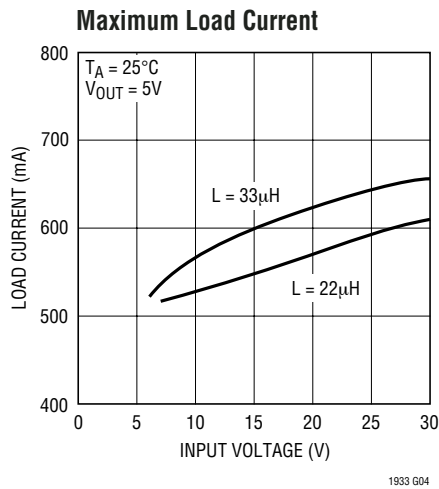
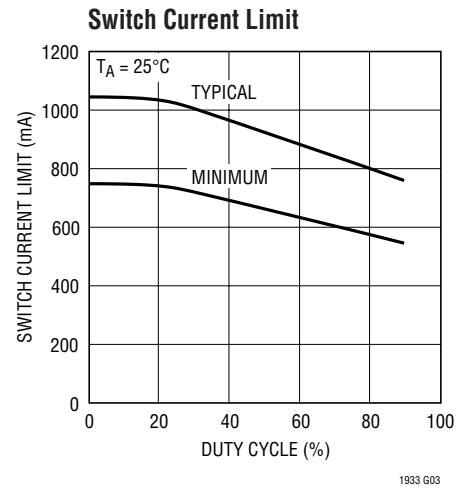
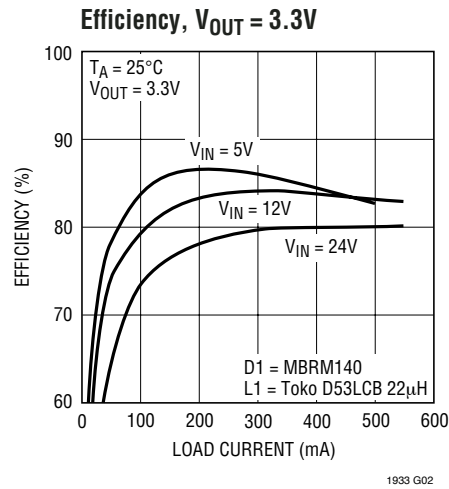
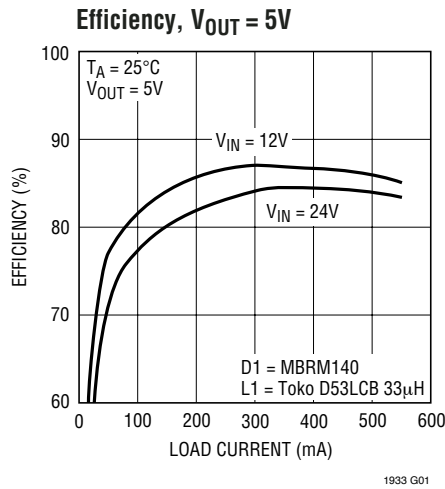

# TYPICAL PERFORMANCE CHARACTERISTICS

**Frequency Foldback**

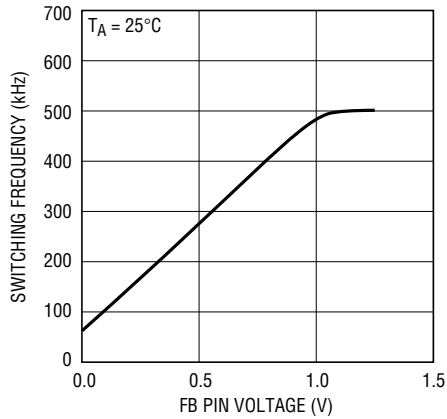

1933 G10

**Soft-Start**

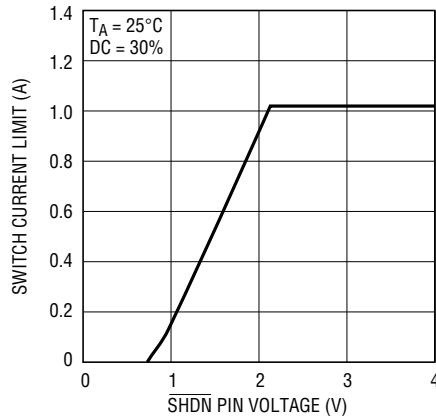

1933 G11

**SHDN Pin Current**

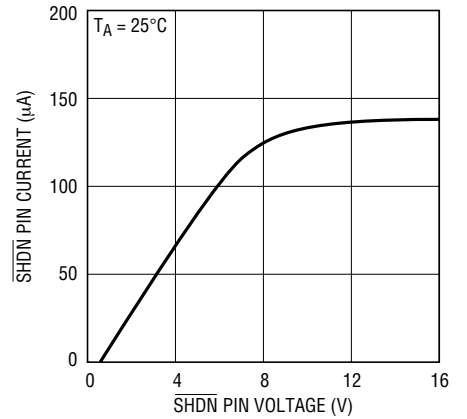

1933 G12

**Typical Minimum Input Voltage**

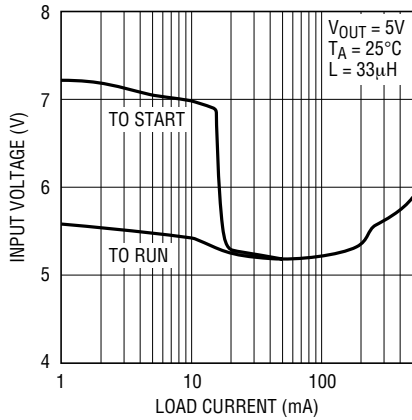

1933 G13

**Typical Minimum Input Voltage**

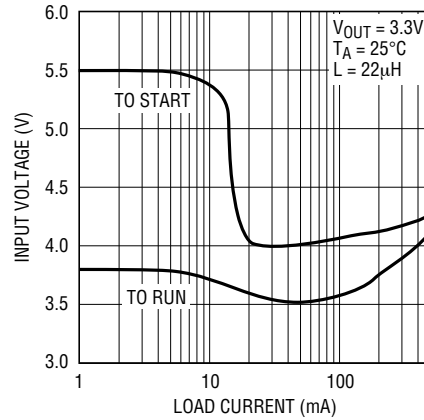

1933 G14

**Switch Current Limit**

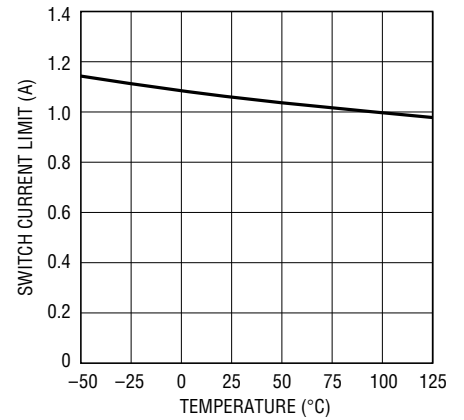

1933 G15

**Operating Waveforms**

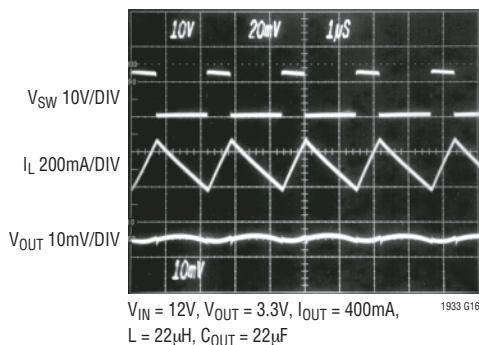

1933 G16

**Operating Waveforms, Discontinuous Mode**

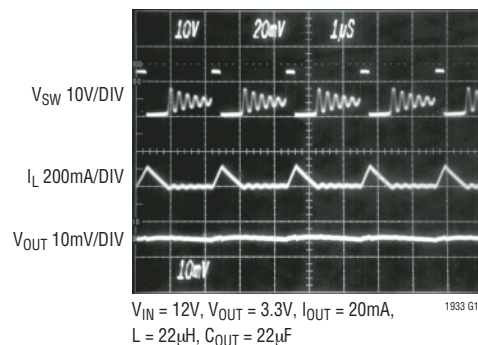

1933 G16

## PIN FUNCTIONS

**BOOST (Pin 1):** The BOOST pin is used to provide a drive voltage, higher than the input voltage, to the internal bipolar NPN power switch.

**GND (Pin 2):** Tie the GND pin to a local ground plane below the LT1933 and the circuit components. Return the feedback divider to this pin.

**FB (Pin 3):** The LT1933 regulates its feedback pin to 1.245V. Connect the feedback resistor divider tap to this pin. Set the output voltage according to  $V_{OUT} = 1.245V (1 + R1/R2)$ . A good value for R2 is 10k.

**SHDN (Pin 4):** The SHDN pin is used to put the LT1933 in shutdown mode. Tie to ground to shut down the LT1933. Tie to 2.3V or more for normal operation. If the shutdown feature is not used, tie this pin to the  $V_{IN}$  pin. SHDN also provides a soft-start function; see the Applications Information section.

**$V_{IN}$  (Pin 5):** The  $V_{IN}$  pin supplies current to the LT1933's internal regulator and to the internal power switch. This pin must be locally bypassed.

**SW (Pin 6):** The SW pin is the output of the internal power switch. Connect this pin to the inductor, catch diode and boost capacitor.

## BLOCK DIAGRAM

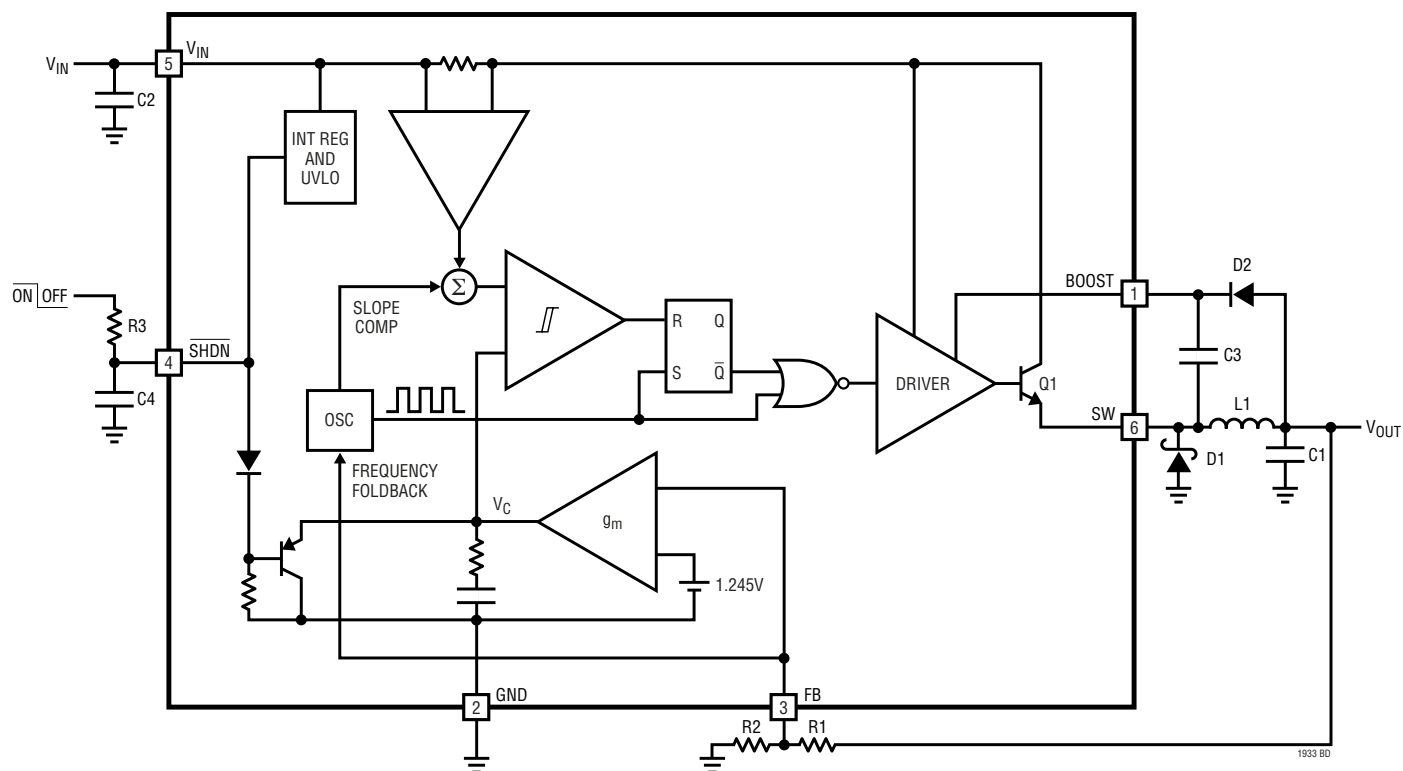

# LT1933

## OPERATION (Refer to Block Diagram)

The LT1933 is a constant frequency, current mode step down regulator. A 500kHz oscillator enables an RS flip-flop, turning on the internal 750mA power switch Q1. An amplifier and comparator monitor the current flowing between the  $V_{IN}$  and SW pins, turning the switch off when this current reaches a level determined by the voltage at  $V_C$ . An error amplifier measures the output voltage through an external resistor divider tied to the FB pin and servos the  $V_C$  node. If the error amplifier's output increases, more current is delivered to the output; if it decreases, less current is delivered. An active clamp (not shown) on the  $V_C$  node provides current limit. The  $V_C$  node is also clamped to the voltage on the  $\overline{\text{SHDN}}$  pin; soft-start is implemented by generating a voltage ramp at the  $\overline{\text{SHDN}}$  pin using an external resistor and capacitor.

An internal regulator provides power to the control circuitry. This regulator includes an undervoltage lockout to prevent switching when  $V_{IN}$  is less than  $\sim 3.35\text{V}$ . The  $\overline{\text{SHDN}}$  pin is used to place the LT1933 in shutdown, disconnecting the output and reducing the input current to less than  $2\mu\text{A}$ .

The switch driver operates from either the input or from the BOOST pin. An external capacitor and diode are used to generate a voltage at the BOOST pin that is higher than the input supply. This allows the driver to fully saturate the internal bipolar NPN power switch for efficient operation.

The oscillator reduces the LT1933's operating frequency when the voltage at the FB pin is low. This frequency foldback helps to control the output current during startup and overload.

## APPLICATIONS INFORMATION

### FB Resistor Network

The output voltage is programmed with a resistor divider between the output and the FB pin. Choose the 1% resistors according to:

$$R1 = R2(V_{OUT}/1.245 - 1)$$

$R2$  should be 20k or less to avoid bias current errors. Reference designators refer to the Block Diagram.

### Input Voltage Range

The input voltage range for LT1933 applications depends on the output voltage and on the absolute maximum ratings of the  $V_{IN}$  and BOOST pins.

The minimum input voltage is determined by either the LT1933's minimum operating voltage of  $\sim 3.35\text{V}$ , or by its maximum duty cycle. The duty cycle is the fraction of time that the internal switch is on and is determined by the input and output voltages:

$$DC = (V_{OUT} + V_D)/(V_{IN} - V_{SW} + V_D)$$

where  $V_D$  is the forward voltage drop of the catch diode ( $\sim 0.4\text{V}$ ) and  $V_{SW}$  is the voltage drop of the internal switch ( $\sim 0.4\text{V}$  at maximum load). This leads to a minimum input

voltage of:

$$V_{IN(MIN)} = (V_{OUT} + V_D)/DC_{MAX} - V_D + V_{SW}$$

with  $DC_{MAX} = 0.88$

The maximum input voltage is determined by the absolute maximum ratings of the  $V_{IN}$  and BOOST pins and by the minimum duty cycle  $DC_{MIN} = 0.08$  (corresponding to a minimum on time of 130ns):

$$V_{IN(MAX)} = (V_{OUT} + V_D)/DC_{MIN} - V_D + V_{SW}$$

Note that this is a restriction on the operating input voltage; the circuit will tolerate transient inputs up to the absolute maximum ratings of the  $V_{IN}$  and BOOST pins.

### Inductor Selection and Maximum Output Current

A good first choice for the inductor value is:

$$L = 5 (V_{OUT} + V_D)$$

where  $V_D$  is the voltage drop of the catch diode ( $\sim 0.4\text{V}$ ) and  $L$  is in  $\mu\text{H}$ . With this value the maximum load current will be above 500mA. The inductor's RMS current rating must be greater than your maximum load current and its saturation current should be about 30% higher. For robust operation in fault conditions the saturation current should

## APPLICATIONS INFORMATION

be ~1A. To keep efficiency high, the series resistance (DCR) should be less than  $0.2\Omega$ . Table 1 lists several vendors and types that are suitable.

Of course, such a simple design guide will not always result in the optimum inductor for your application. A larger value provides a slightly higher maximum load current, and will reduce the output voltage ripple. If your load is lower than 500mA, then you can decrease the value of the inductor and operate with higher ripple current. This allows you to use a physically smaller inductor, or one with a lower DCR resulting in higher efficiency. There are several graphs in the Typical Performance Characteristics section of this data sheet that show the maximum load current as a function of input voltage and inductor value for several popular output voltages. Low inductance may result in discontinuous mode operation, which is OK, but further reduces maximum load current. For details of maximum output current and discontinuous mode operation, see Linear Technology Application Note 44. Finally, for duty cycles greater than 50% ( $V_{OUT}/V_{IN} < 0.5$ ), there is a minimum inductance required to avoid subharmonic oscillations. Choosing L greater than  $3(V_{OUT} + V_D) \mu\text{H}$  prevents subharmonic oscillations at all duty cycles.

### Catch Diode

A 0.5A or 1A Schottky diode is recommended for the catch diode, D1. The diode must have a reverse voltage rating equal to or greater than the maximum input voltage. The ON Semiconductor MBR0540 is a good choice; it is rated

for 0.5A forward current and a maximum reverse voltage of 40V. The MBRM140 provides better efficiency, and will handle extended overload conditions.

### Input Capacitor

Bypass the input of the LT1933 circuit with a  $2.2\mu\text{F}$  or higher value ceramic capacitor of X7R or X5R type. Y5V types have poor performance over temperature and applied voltage, and should not be used. A  $2.2\mu\text{F}$  ceramic is adequate to bypass the LT1933 and will easily handle the ripple current. However, if the input power source has high impedance, or there is significant inductance due to long wires or cables, additional bulk capacitance may be necessary. This can be provided with a low performance electrolytic capacitor.

Step-down regulators draw current from the input supply in pulses with very fast rise and fall times. The input capacitor is required to reduce the resulting voltage ripple at the LT1933 and to force this very high frequency switching current into a tight local loop, minimizing EMI. A  $2.2\mu\text{F}$  capacitor is capable of this task, but only if it is placed close to the LT1933 and the catch diode; see the PCB Layout section. A second precaution regarding the ceramic input capacitor concerns the maximum input voltage rating of the LT1933. A ceramic input capacitor combined with trace or cable inductance forms a high quality (under damped) tank circuit. If the LT1933 circuit is plugged into a live supply, the input voltage can ring to twice its nominal value, possibly exceeding the LT1933's

**Table 1. Inductor Vendors**

Vendor	URL	Part Series	Inductance Range ( $\mu\text{H}$ )	Size (mm)
Coilcraft	www.coilcraft.com	DO1608C	10 to 22	$2.9 \times 4.5 \times 6.6$
		MSS5131	10 to 22	$3.1 \times 5.1 \times 5.1$
		MSS6122	10 to 33	$2.2 \times 6.1 \times 6.1$
Sumida	www.sumida.com	CR43	10 to 22	$3.5 \times 4.3 \times 4.8$
		CDRH4D28	10 to 33	$3.0 \times 5.0 \times 5.0$
		CDRH5D28	22 to 47	$3.0 \times 5.7 \times 5.7$
Toko	www.toko.com	D52LC	10 to 22	$2.0 \times 5.0 \times 5.0$
		D53LC	22 to 47	$3.0 \times 5.0 \times 5.0$
Würth Elektronik	www.we-online.com	WE-TPC MH	10 to 22	$2.8 \times 4.8 \times 4.8$
		WE-PD4 S	10 to 22	$2.9 \times 4.5 \times 6.6$
		WE-PD2 S	10 to 47	$3.2 \times 4.0 \times 4.5$

## APPLICATIONS INFORMATION

voltage rating. This situation is easily avoided; see the Hot Plugging Safely section.

### Output Capacitor

The output capacitor has two essential functions. Along with the inductor, it filters the square wave generated by the LT1933 to produce the DC output. In this role it determines the output ripple, and low impedance at the switching frequency is important. The second function is to store energy in order to satisfy transient loads and stabilize the LT1933's control loop.

Ceramic capacitors have very low equivalent series resistance (ESR) and provide the best ripple performance. A good value is

$$C_{OUT} = 60/V_{OUT}$$

where  $C_{OUT}$  is in  $\mu\text{F}$ . Use X5R or X7R types, and keep in mind that a ceramic capacitor biased with  $V_{OUT}$  will have less than its nominal capacitance. This choice will provide low output ripple and good transient response. Transient performance can be improved with a high value capacitor, but a phase lead capacitor across the feedback resistor  $R1$

may be required to get the full benefit (see the Compensation section).

High performance electrolytic capacitors can be used for the output capacitor. Low ESR is important, so choose one that is intended for use in switching regulators. The ESR should be specified by the supplier, and should be  $0.1\Omega$  or less. Such a capacitor will be larger than a ceramic capacitor and will have a larger capacitance, because the capacitor must be large to achieve low ESR. Table 2 lists several capacitor vendors.

Figure 1 shows the transient response of the LT1933 with several output capacitor choices. The output is 3.3V. The load current is stepped from 100mA to 400mA and back to 100mA, and the oscilloscope traces show the output voltage. The upper photo shows the recommended value. The second photo shows the improved response (less voltage drop) resulting from a larger output capacitor and a phase lead capacitor. The last photo shows the response to a high performance electrolytic capacitor. Transient performance is improved due to the large output capacitance, but output ripple (as shown by the broad trace) has increased because of the higher ESR of this capacitor.

**Table 2. Capacitor Vendors**

Vendor	Phone	URL	Part Series	Comments
Panasonic	(714) 373-7366	www.panasonic.com	Ceramic, Polymer, Tantalum	EEF Series
Kemet	(864) 963-6300	www.kemet.com	Ceramic, Tantalum	T494, T495
Sanyo	(408) 749-9714	www.sanyovideo.com	Ceramic, Polymer, Tantalum	POSCAP
Murata	(404) 436-1300	www.murata.com	Ceramic	
AVX		www.avxcorp.com	Ceramic, Tantalum	TPS Series
Taiyo Yuden	(864) 963-6300	www.taiyo-yuden.com	Ceramic	



APPLICATIONS INFORMATION

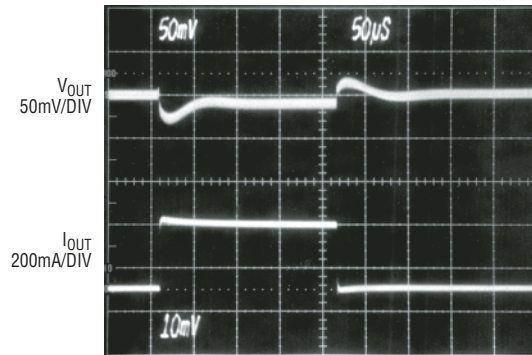
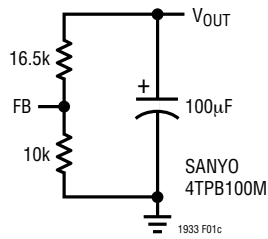
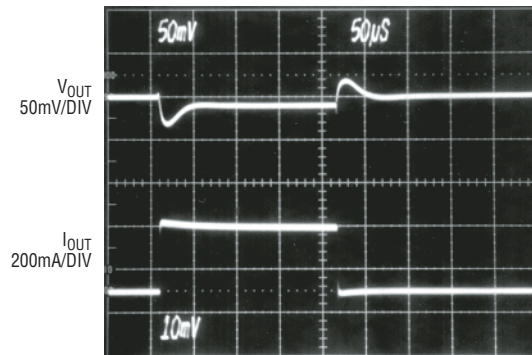
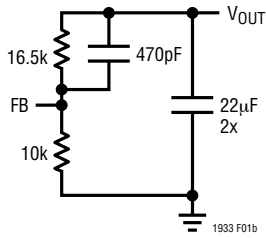
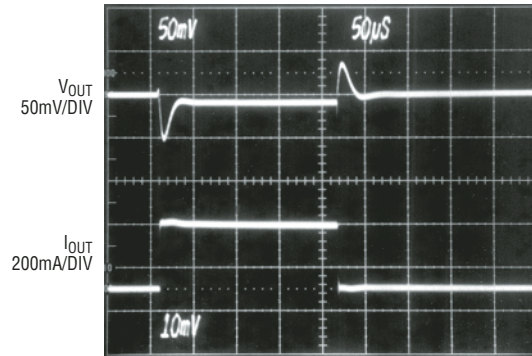
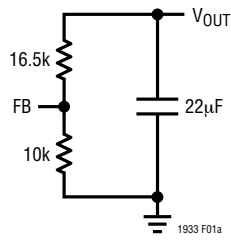

Figure 1. Transient Load Response of the LT1933 with Different Output Capacitors as the Load Current is Stepped from 100mA to 400mA.  $V_{IN} = 12V$ ,  $V_{OUT} = 3.3V$ ,  $L = 22\mu H$ .

## APPLICATIONS INFORMATION

### BOOST Pin Considerations

Capacitor C3 and diode D2 are used to generate a boost voltage that is higher than the input voltage. In most cases a 0.1 $\mu$ F capacitor and fast switching diode (such as the 1N4148 or 1N914) will work well. Figure 2 shows two ways to arrange the boost circuit. The BOOST pin must be at least 2.3V above the SW pin for best efficiency. For outputs of 3V and above, the standard circuit (Figure 2a) is best. For outputs between 2.5V and 3V, use a 0.47 $\mu$ F capacitor and a small Schottky diode (such as the BAT-54). For lower output voltages the boost diode can be tied to the input (Figure 2b). The circuit in Figure 2a is more efficient because the BOOST pin current comes from a lower voltage source. You must also be sure that the maximum voltage rating of the BOOST pin is not exceeded.

The minimum operating voltage of an LT1933 application is limited by the undervoltage lockout (~3.35V) and by the maximum duty cycle as outlined above. For proper startup, the minimum input voltage is also limited by the boost circuit. If the input voltage is ramped slowly, or the LT1933 is turned on with its SHDN pin when the output is already in regulation, then the boost capacitor may not be fully charged. Because the boost capacitor is charged with the

energy stored in the inductor, the circuit will rely on some minimum load current to get the boost circuit running properly. This minimum load will depend on input and output voltages, and on the arrangement of the boost circuit. The minimum load generally goes to zero once the circuit has started. Figure 3 shows a plot of minimum load to start and to run as a function of input voltage. In many cases the discharged output capacitor will present a load to the switcher which will allow it to start. The plots show the worst-case situation where  $V_{IN}$  is ramping very slowly. For lower start-up voltage, the boost diode can be tied to  $V_{IN}$ ; however, this restricts the input range to one-half of the absolute maximum rating of the BOOST pin.

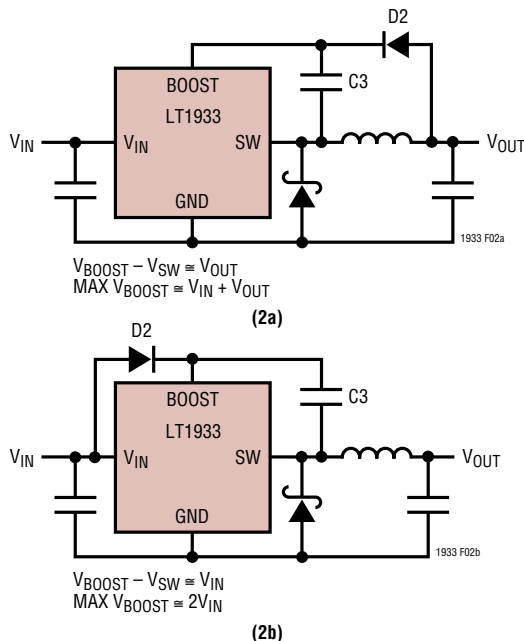

Figure 2. Two Circuits for Generating the Boost Voltage

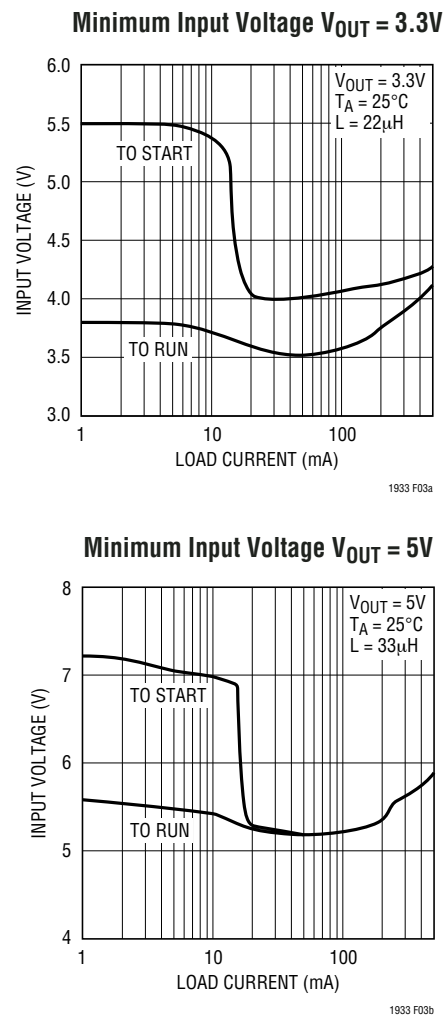

Figure 3. The Minimum Input Voltage Depends on Output Voltage, Load Current and Boost Circuit

## APPLICATIONS INFORMATION

At light loads, the inductor current becomes discontinuous and the effective duty cycle can be very high. This reduces the minimum input voltage to approximately 300mV above  $V_{OUT}$ . At higher load currents, the inductor current is continuous and the duty cycle is limited by the maximum duty cycle of the LT1933, requiring a higher input voltage to maintain regulation.

### Soft-Start

The  $\overline{\text{SHDN}}$  pin can be used to soft-start the LT1933, reducing the maximum input current during start up. The  $\overline{\text{SHDN}}$  pin is driven through an external RC filter to create a voltage ramp at this pin. Figure 4 shows the start up waveforms with and without the soft-start circuit. By choosing a large RC time constant, the peak start up current can be reduced to the current that is required to regulate the output, with no overshoot. Choose the value of the resistor so that it can supply 60 $\mu\text{A}$  when the  $\overline{\text{SHDN}}$  pin reaches 2.3V.

### Shorted and Reversed Input Protection

If the inductor is chosen so that it won't saturate excessively, an LT1933 buck regulator will tolerate a shorted output. There is another situation to consider in systems where the output will be held high when the input to the LT1933 is absent. This may occur in battery charging applications or in battery backup systems where a battery or some other supply is diode OR-ed with the LT1933's output. If the  $V_{IN}$  pin is allowed to float and the  $\overline{\text{SHDN}}$  pin is held high (either by a logic signal or because it is tied to  $V_{IN}$ ), then the LT1933's internal circuitry will pull its quiescent current through its SW pin. This is fine if your system can tolerate a few mA in this state. If you ground the  $\overline{\text{SHDN}}$  pin, the SW pin current will drop to essentially zero. However, if the  $V_{IN}$  pin is grounded while the output is held high, then parasitic diodes inside the LT1933 can

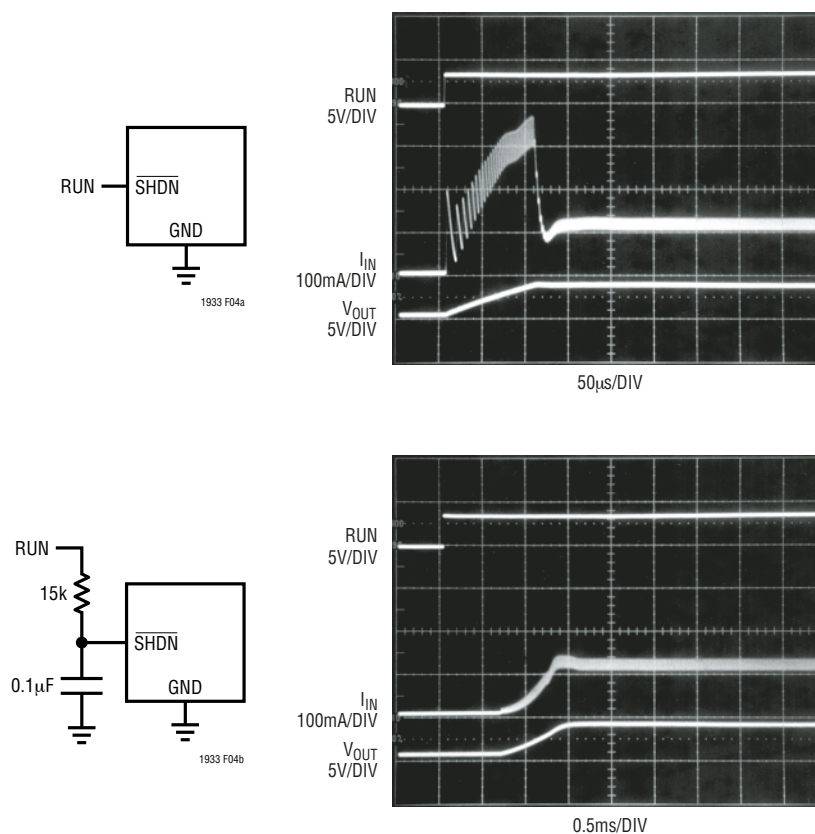
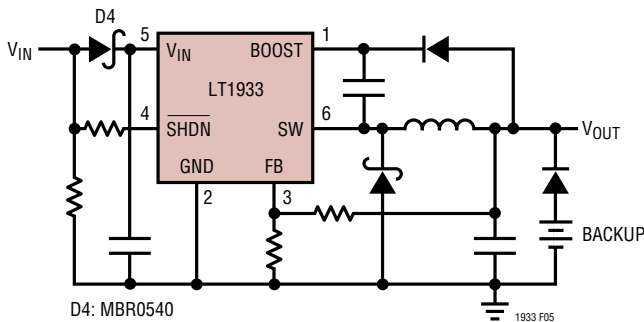

Figure 4. To Soft-Start the LT1933, Add a Resistor and Capacitor to the  $\overline{\text{SHDN}}$  Pin.  $V_{IN} = 12\text{V}$ ,  $V_{OUT} = 3.3\text{V}$ ,  $C_{OUT} = 22\mu\text{F}$ ,  $R_{LOAD} = 10\Omega$ .

## APPLICATIONS INFORMATION

pull large currents from the output through the SW pin and the  $V_{IN}$  pin. Figure 5 shows a circuit that will run only when the input voltage is present and that protects against a shorted or reversed input.

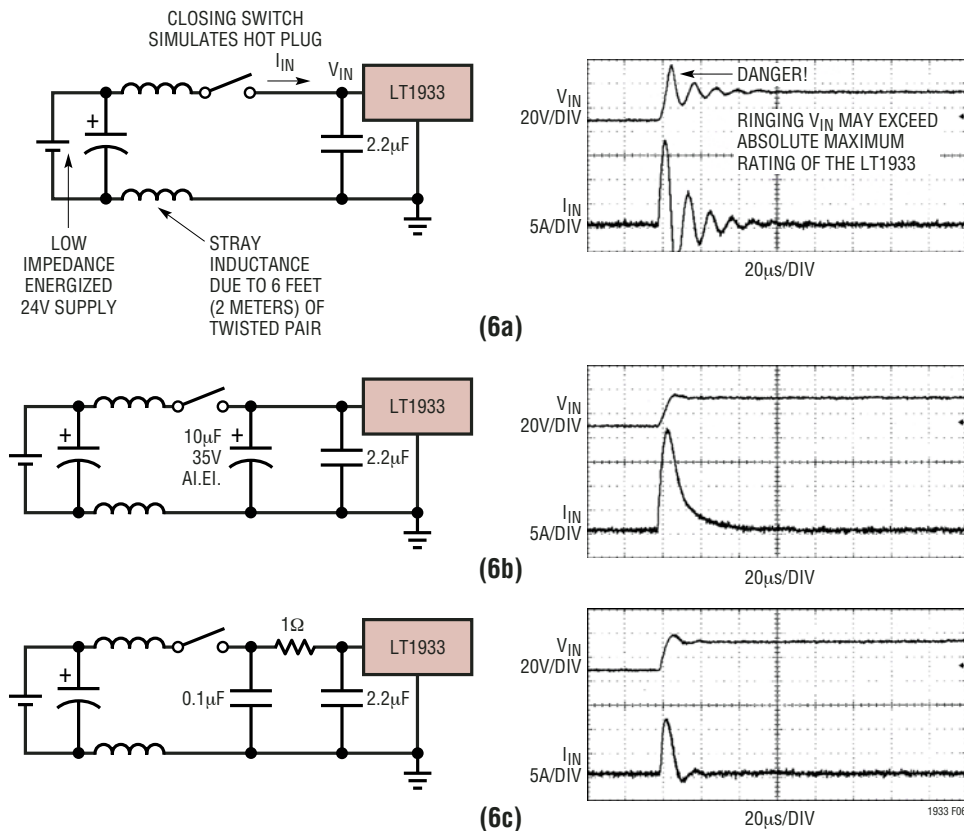

**Figure 5. Diode D4 Prevents a Shorted Input from Discharging a Backup Battery Tied to the Output; It Also Protects the Circuit from a Reversed Input. The LT1933 Runs Only When the Input is Present**

### Hot Plugging Safely

The small size, robustness and low impedance of ceramic capacitors make them an attractive option for the input bypass capacitor of LT1933 circuits. However, these capacitors can cause problems if the LT1933 is plugged into a live supply (see Linear Technology Application Note 88 for a complete discussion). The low loss ceramic capacitor combined with stray inductance in series with the power source forms an under damped tank circuit, and the voltage at the  $V_{IN}$  pin of the LT1933 can ring to twice the nominal input voltage, possibly exceeding the LT1933's rating and damaging the part. If the input supply is poorly controlled or the user will be plugging the LT1933 into an energized supply, the input network should be designed to prevent this overshoot.

Figure 6 shows the waveforms that result when an LT1933 circuit is connected to a 24V supply through six feet of 24-gauge twisted pair. The first plot is the response with a



**Figure 6. A Well Chosen Input Network Prevents Input Voltage Overshoot and Ensures Reliable Operation When the LT1933 is Connected to a Live Supply**

## APPLICATIONS INFORMATION

2.2 $\mu$ F ceramic capacitor at the input. The input voltage rings as high as 35V and the input current peaks at 20A. One method of damping the tank circuit is to add another capacitor with a series resistor to the circuit. In Figure 6b an aluminum electrolytic capacitor has been added. This capacitor's high equivalent series resistance damps the circuit and eliminates the voltage overshoot. The extra capacitor improves low frequency ripple filtering and can slightly improve the efficiency of the circuit, though it is likely to be the largest component in the circuit. An alternative solution is shown in Figure 6c. A 1 $\Omega$  resistor is added in series with the input to eliminate the voltage overshoot (it also reduces the peak input current). A 0.1 $\mu$ F capacitor improves high frequency filtering. This solution is smaller and less expensive than the electrolytic capacitor. For high input voltages its impact on efficiency is minor, reducing efficiency less than one half percent for a 5V output at full load operating from 24V.

### Frequency Compensation

The LT1933 uses current mode control to regulate the output. This simplifies loop compensation. In particular, the LT1933 does not require the ESR of the output capacitor for stability allowing the use of ceramic capacitors to achieve low output ripple and small circuit size.

Figure 7 shows an equivalent circuit for the LT1933 control loop. The error amp is a transconductance amplifier with finite output impedance. The power section, consisting of the modulator, power switch and inductor, is modeled as a transconductance amplifier generating an output current proportional to the voltage at the  $V_C$  node. Note that the output capacitor integrates this current, and

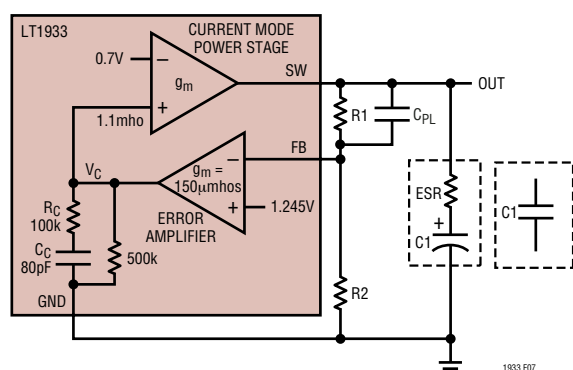

Figure 7. Model for Loop Response

that the capacitor on the  $V_C$  node ( $C_C$ ) integrates the error amplifier output current, resulting in two poles in the loop.  $R_C$  provides a zero. With the recommended output capacitor, the loop crossover occurs above the  $R_C C_C$  zero. This simple model works well as long as the value of the inductor is not too high and the loop crossover frequency is much lower than the switching frequency. With a larger ceramic capacitor (very low ESR), crossover may be lower and a phase lead capacitor ( $C_{PL}$ ) across the feedback divider may improve the phase margin and transient response. Large electrolytic capacitors may have an ESR large enough to create an additional zero, and the phase lead may not be necessary.

If the output capacitor is different than the recommended capacitor, stability should be checked across all operating conditions, including load current, input voltage and temperature. The LT1375 data sheet contains a more thorough discussion of loop compensation and describes how to test the stability using a transient load.

### PCB Layout

For proper operation and minimum EMI, care must be taken during printed circuit board layout. Figure 8 shows the recommended component placement with trace, ground plane and via locations. Note that large, switched currents flow in the LT1933's  $V_{IN}$  and SW pins, the catch diode ( $D_1$ ) and the input capacitor ( $C_2$ ). The loop formed by these components should be as small as possible and tied to system ground in only one place. These components, along with the inductor and output capacitor,

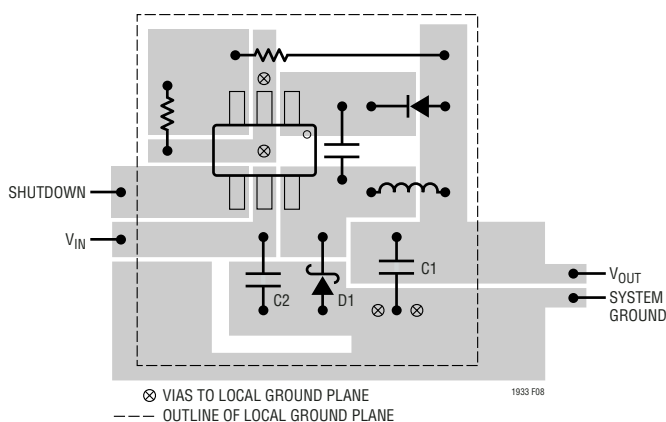

Figure 8. A Good PCB Layout Ensures Proper, Low EMI Operation

# LT1933

should be placed on the same side of the circuit board, and their connections should be made on that layer. Place a local, unbroken ground plane below these components, and tie this ground plane to system ground at one location, ideally at the ground terminal of the output capacitor C1. The SW and BOOST nodes should be as small as possible. Finally, keep the FB node small so that the ground pin and ground traces will shield it from the SW and BOOST nodes. Include two vias near the GND pin of the LT1933 to help remove heat from the LT1933 to the ground plane.

## High Temperature Considerations

The die temperature of the LT1933 must be lower than the maximum rating of 125°C. This is generally not a concern unless the ambient temperature is above 85°C. For higher temperatures, care should be taken in the layout of the circuit to ensure good heat sinking of the LT1933. The maximum load current should be derated as the ambient temperature approaches 125°C.

The die temperature is calculated by multiplying the LT1933 power dissipation by the thermal resistance from junction to ambient. Power dissipation within the LT1933 can be

estimated by calculating the total power loss from an efficiency measurement and subtracting the catch diode loss. The resulting temperature rise at full load is nearly independent of input voltage. Thermal resistance depends on the layout of the circuit board, but a value of 125°C/W is typical.

Die temperature rise was measured on a two-layer, five by five cm circuit board in still air. The LT1933 producing 5V at 500mA showed a temperature rise of 28°C, allowing it to deliver full load to 97°C ambient. Above this temperature the load current should be reduced. For 3.3V at 500mA the temperature rise is 24°C.

## Other Linear Technology Publications

Application notes AN19, AN35 and AN44 contain more detailed descriptions and design information for Buck regulators and other switching regulators. The LT1376 data sheet has a more extensive discussion of output ripple, loop compensation and stability testing. Design Note DN100 shows how to generate a bipolar output supply using a Buck regulator.

## TYPICAL APPLICATIONS

### 1.8V Step-Down Converter

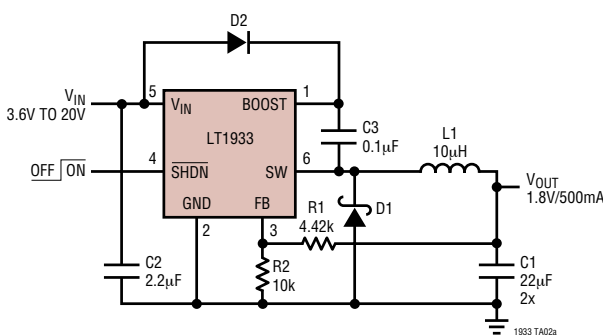

### 5V Step-Down Converter

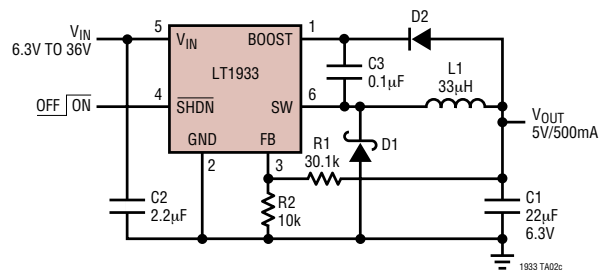

### 3.3V Step-Down Converter

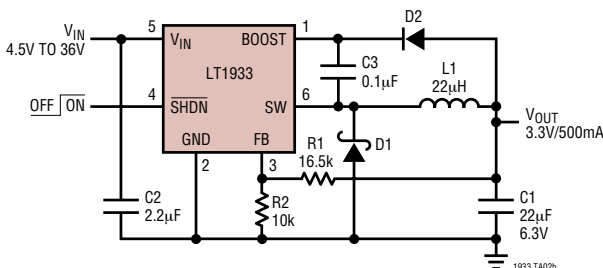

### 12V Step-Down Converter

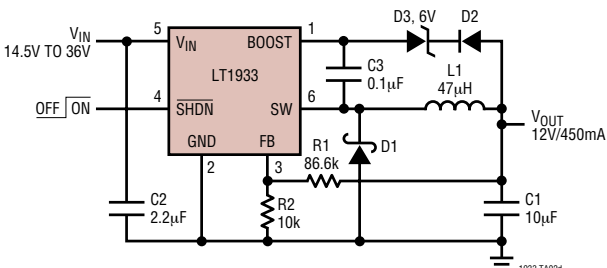

# PACKAGE DESCRIPTION

**S6 Package**  
**6-Lead Plastic SOT-23**  
 (Reference LTC DWG # 05-08-1634)

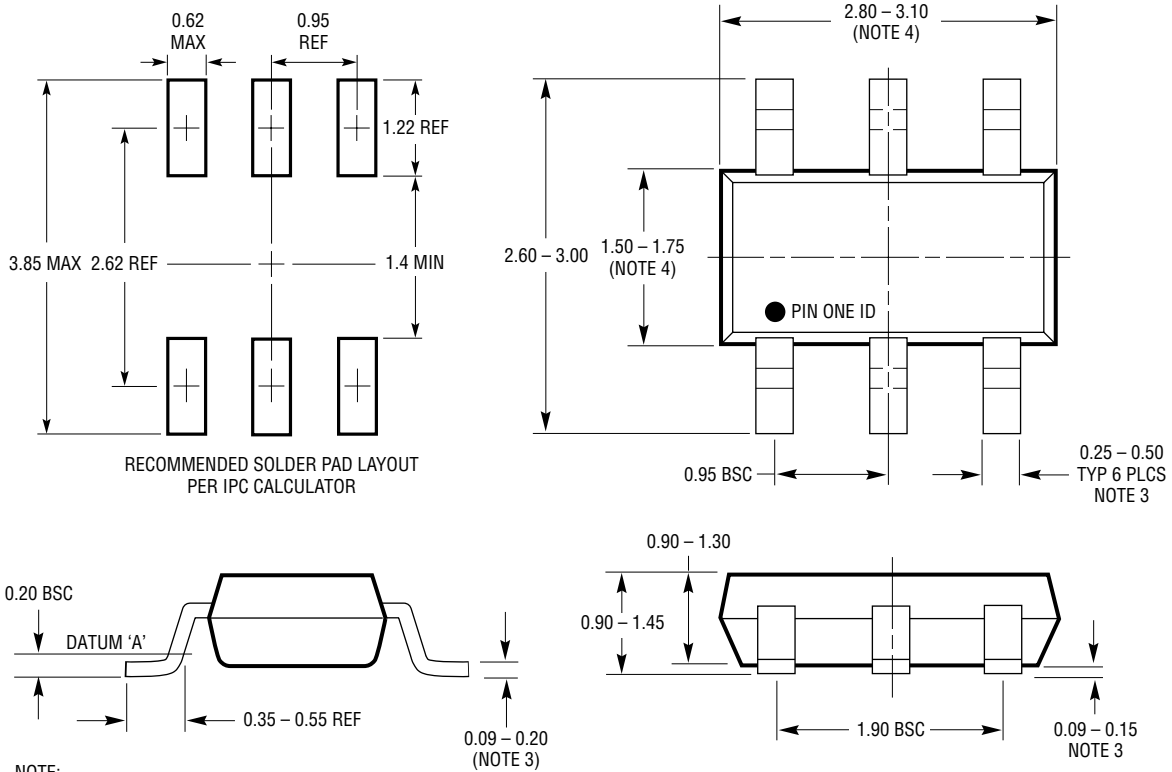

- NOTE:
1. DIMENSIONS ARE IN MILLIMETERS
  2. DRAWING NOT TO SCALE
  3. DIMENSIONS ARE INCLUSIVE OF PLATING
  4. DIMENSIONS ARE EXCLUSIVE OF MOLD FLASH AND METAL BURR
  5. MOLD FLASH SHALL NOT EXCEED 0.254mm
  6. PACKAGE EIAJ REFERENCE IS SC-74A (EIAJ)

**ATTENTION: ORIGINAL SOT23-6L PACKAGE.**  
 MOST SOT23-6L PRODUCTS CONVERTED TO THIN SOT23 PACKAGE, DRAWING # 05-08-1636 AFTER APPROXIMATELY APRIL 2001 SHIP DATE

S6 SOT-23 0502

**TYPICAL APPLICATIONS**

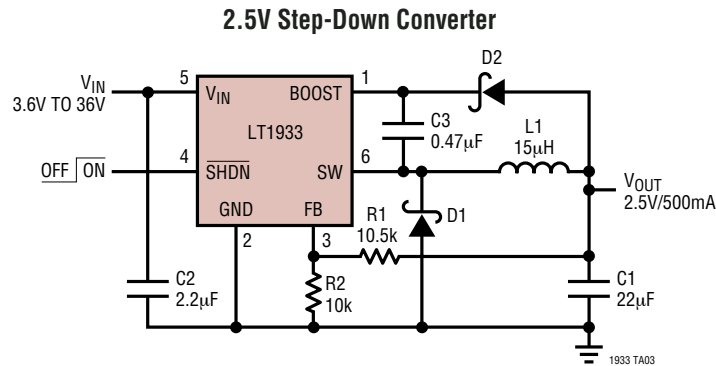

**RELATED PARTS**

PART NUMBER	DESCRIPTION	COMMENTS
LT1074/LT1074HV	4.4A I <sub>OUT</sub> , 100kHz, High Efficiency Step-Down DC/DC Converter	V <sub>IN</sub> : 7.3V to 45V/64V, V <sub>OUT(MIN)</sub> = 2.21V, I <sub>Q</sub> = 8.5mA, I <sub>SD</sub> = 10µA, DD-5/DD-7, TO220-5/ TO220-7 Packages
LT1076/LT1076HV	1.6A I <sub>OUT</sub> , 100kHz, High Efficiency Step-Down DC/DC Converter	V <sub>IN</sub> : 7.3V to 45V/64V, V <sub>OUT(MIN)</sub> = 2.21V, I <sub>Q</sub> = 8.5mA, I <sub>SD</sub> = 10µA, DD-5/DD-7, TO220-5/ TO220-7 Packages
LT1676	60V, 440mA I <sub>OUT</sub> , 100kHz, High Efficiency Step-Down DC/DC Converter	V <sub>IN</sub> : 7.4V to 60V, V <sub>OUT(MIN)</sub> = 1.24V, I <sub>Q</sub> = 3.2mA, I <sub>SD</sub> = 2.5µA, S8 Package
LT1765	25V, 2.75A I <sub>OUT</sub> , 1.25MHz, High Efficiency Step-Down DC/DC Converter	V <sub>IN</sub> : 3V to 25V, V <sub>OUT(MIN)</sub> = 1.2V, I <sub>Q</sub> = 1mA, I <sub>SD</sub> = 15µA, S8, TSSOP16E Packages
LT1766	60V, 1.2A I <sub>OUT</sub> , 200kHz, High Efficiency Step-Down DC/DC Converter	V <sub>IN</sub> : 5.5V to 60V, V <sub>OUT(MIN)</sub> = 1.2V, I <sub>Q</sub> = 2.5mA, I <sub>SD</sub> = 25µA, TSSOP16/TSSOP16E Packages
LT1767	25V, 1.2A I <sub>OUT</sub> , 1.25MHz, High Efficiency Step-Down DC/DC Converter	V <sub>IN</sub> : 3V to 25V, V <sub>OUT(MIN)</sub> = 1.2V, I <sub>Q</sub> = 1mA, I <sub>SD</sub> = 6µA, MS8/MS8E Packages
LT1776	40V, 550mA I <sub>OUT</sub> , 200kHz, High Efficiency Step-Down DC/DC Converter	V <sub>IN</sub> : 7.4V to 40V, V <sub>OUT(MIN)</sub> = 1.24V, I <sub>Q</sub> = 3.2mA, I <sub>SD</sub> = 30µA, N8, S8 Packages
LT1940	25V, Dual 1.4A I <sub>OUT</sub> , 1.1MHz, High Efficiency Step-Down DC/DC Converter	V <sub>IN</sub> : 3.6V to 25V, V <sub>OUT(MIN)</sub> = 1.25V, I <sub>Q</sub> = 3.8mA, I <sub>SD</sub> = <30µA, TSSOP16E Package
LT1956	60V, 1.2A I <sub>OUT</sub> , 500kHz, High Efficiency Step-Down DC/DC Converter	V <sub>IN</sub> : 5.5V to 60V, V <sub>OUT(MIN)</sub> = 1.2V, I <sub>Q</sub> = 2.5mA, I <sub>SD</sub> = 25µA, TSSOP16/TSSOP16E Packages
LT1976	60V, 1.2A I <sub>OUT</sub> , 200kHz, High Efficiency Step-Down DC/DC Converter with Burst-Mode®	V <sub>IN</sub> : 3.3V to 60V, V <sub>OUT(MIN)</sub> = 1.2V, I <sub>Q</sub> = 100µA, I <sub>SD</sub> = <1µA, TSSOP16E Package
LT3010	80V, 50mA, Low Noise Linear Regulator	V <sub>IN</sub> : 1.5V to 80V, V <sub>OUT(MIN)</sub> = 1.28V, I <sub>Q</sub> = 30µA, I <sub>SD</sub> = <1µA, MS8E Package
LT3407	Dual 600mA I <sub>OUT</sub> , 1.5MHz, Synchronous Step-Down DC/DC Converter	V <sub>IN</sub> : 2.5V to 5.5V, V <sub>OUT(MIN)</sub> = 0.6V, I <sub>Q</sub> = 40µA, I <sub>SD</sub> = <1µA, MS10E Package
LT3412	2.5A I <sub>OUT</sub> , 4MHz, Synchronous Step-Down DC/DC Converter	V <sub>IN</sub> : 2.5V to 5.5V, V <sub>OUT(MIN)</sub> = 0.8V, I <sub>Q</sub> = 60µA, I <sub>SD</sub> = <1µA, TSSOP16E Package
LTC3414	4A I <sub>OUT</sub> , 4MHz, Synchronous Step-Down DC/DC Converter	V <sub>IN</sub> : 2.3V to 5.5V, V <sub>OUT(MIN)</sub> = 0.8V, I <sub>Q</sub> = 64µA, I <sub>SD</sub> = <1µA, TSSOP20E Package
LT3430/LT3431	60V, 2.75A I <sub>OUT</sub> , 200kHz/500kHz, High Efficiency Step-Down DC/DC Converter	V <sub>IN</sub> : 5.5V to 60V, V <sub>OUT(MIN)</sub> = 1.2V, I <sub>Q</sub> = 2.5mA, I <sub>SD</sub> = 30µA, TSSOP16E Package

Burst Mode is a registered trademark of Linear Technology Corporation.