

IS63LV1024L

128K x 8 HIGH-SPEED CMOS STATIC RAM 3.3V REVOLUTIONARY PINOUT

AUGUST 2002

FEATURES

- High-speed access times:
8, 10, 12 ns
- High-performance, low-power CMOS process
- Multiple center power and ground pins for greater noise immunity
- Easy memory expansion with \overline{CE} and \overline{OE} options
- \overline{CE} power-down
- Fully static operation: no clock or refresh required
- TTL compatible inputs and outputs
- Single 3.3V power supply
- Packages available:
 - 32-pin 300-mil SOJ
 - 32-pin 400-mil SOJ

- 32-pin TSOP (Type II)
- 32-pin STSOP (Type I)
- 36-pin BGA (8mmx10mm)

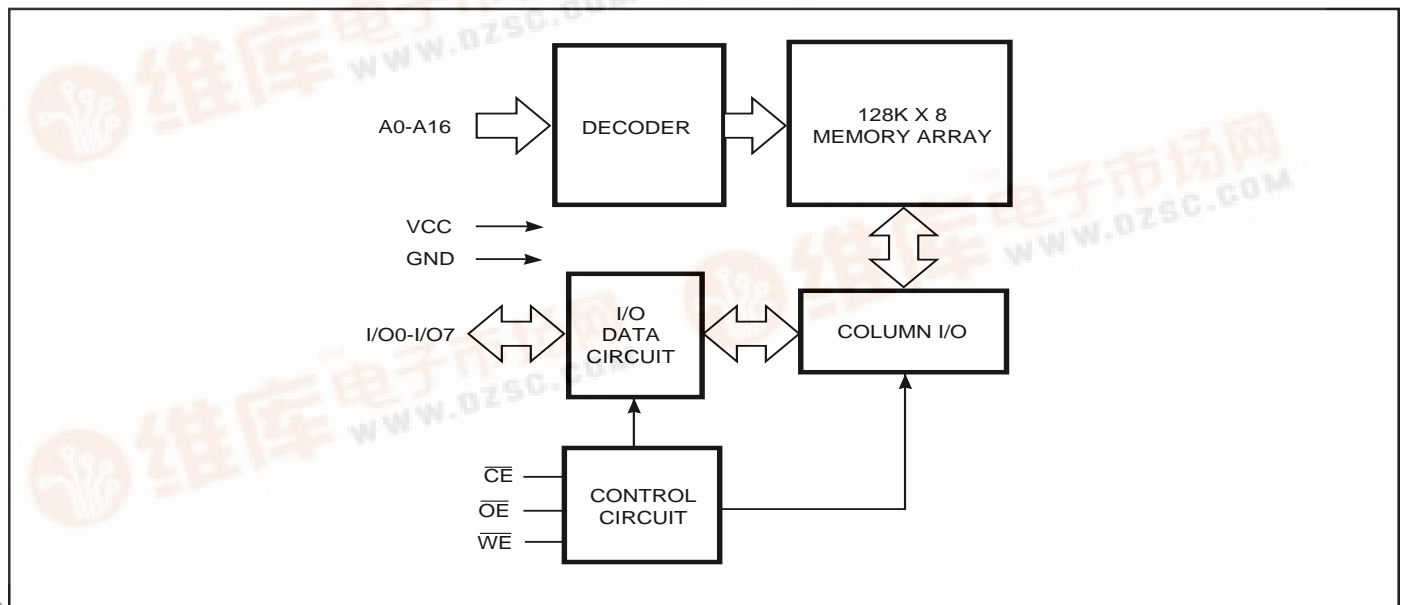
DESCRIPTION

The *ISSI* IS63LV1024L is a very high-speed, low power, 131,072-word by 8-bit CMOS static RAM in revolutionary pinout. The IS63LV1024L is fabricated using *ISSI*'s high-performance CMOS technology. This highly reliable process coupled with innovative circuit design techniques, yields higher performance and low power consumption devices.

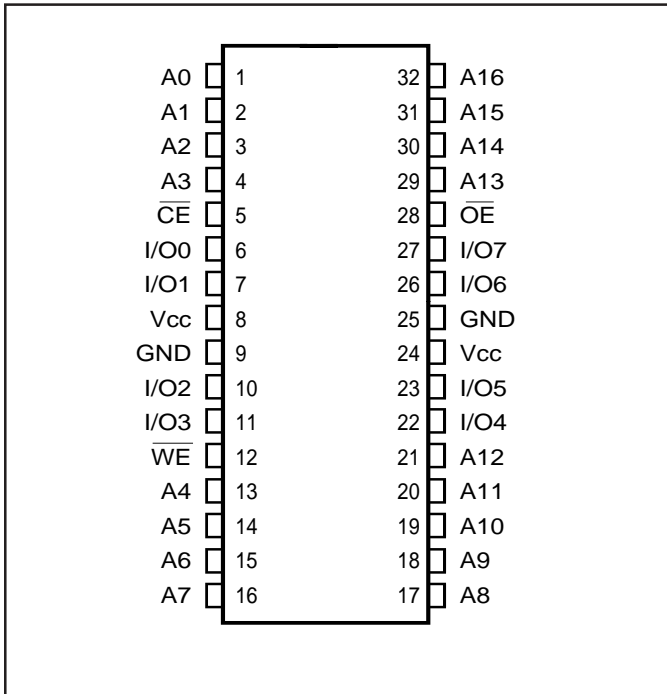
When \overline{CE} is HIGH (deselected), the device assumes a standby mode at which the power dissipation can be reduced down to 250 μ W (typical) with CMOS input levels.

The IS63LV1024L operates from a single 3.3V power supply and all inputs are TTL-compatible.

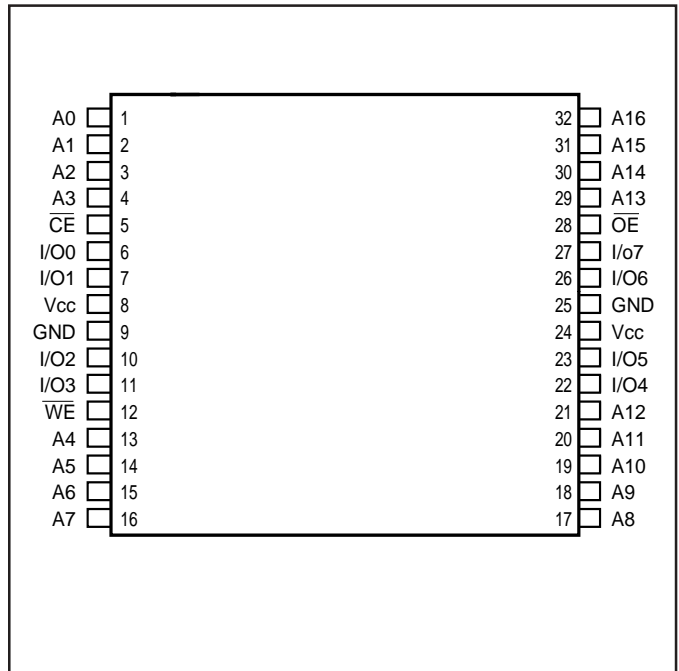
FUNCTIONAL BLOCK DIAGRAM



PIN CONFIGURATION
32-Pin SOJ



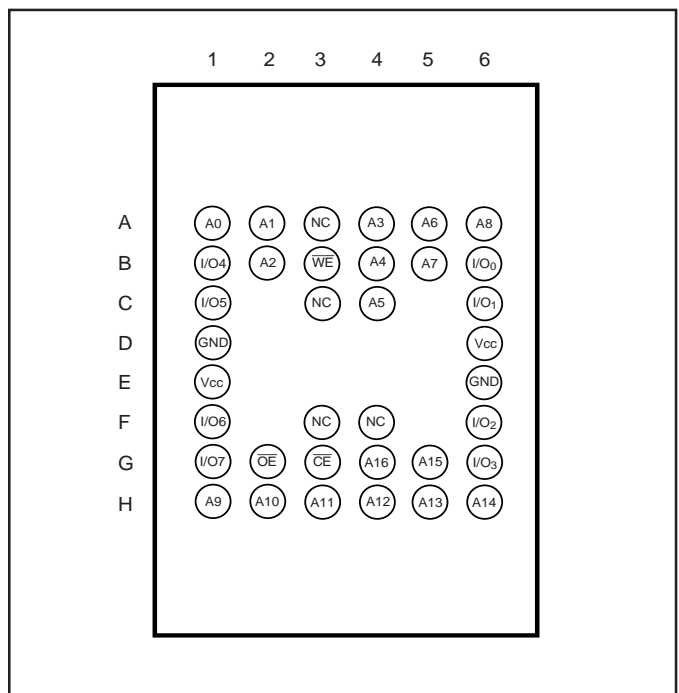
PIN CONFIGURATION
32-Pin TSOP (Type II) (T)
32-Pin STSOP (Type I) (H)



PIN DESCRIPTIONS

A0-A16	Address Inputs
\overline{CE}	Chip Enable Input
\overline{OE}	Output Enable Input
\overline{WE}	Write Enable Input
I/O0-I/O7	Bidirectional Ports
Vcc	Power
GND	Ground

PIN CONFIGURATION
36-mini BGA (B) (8 mm x 10 mm)



TRUTH TABLE

Mode	\overline{WE}	\overline{CE}	\overline{OE}	I/O Operation	Vcc Current
Not Selected (Power-down)	X	H	X	High-Z	ISB1, ISB2
Output Disabled	H	L	H	High-Z	Icc1, Icc2
Read	H	L	L	DOUT	Icc1, Icc2
Write	L	L	X	DIN	Icc1, Icc2

ABSOLUTE MAXIMUM RATINGS⁽¹⁾

Symbol	Parameter	Value	Unit
V _{TERM}	Terminal Voltage with Respect to GND	-0.5 to V _{CC} + 0.5	V
T _{BIAS}	Temperature Under Bias	-55 to +125	°C
T _{STG}	Storage Temperature	-65 to +150	°C
P _T	Power Dissipation	1.0	W

Notes:

1. Stress greater than those listed under ABSOLUTE MAXIMUM RATINGS may cause permanent damage to the device. This is a stress rating only and functional operation of the device at these or any other conditions above those indicated in the operational sections of this specification is not implied. Exposure to absolute maximum rating conditions for extended periods may affect reliability.

OPERATING RANGE

Range	Ambient Temperature	V _{CC}
Commercial	0°C to +70°C	3.3V ± 0.3V
Industrial	-40°C to +85°C	3.3V ± 0.15V

DC ELECTRICAL CHARACTERISTICS (Over Operating Range)

Symbol	Parameter	Test Conditions	Min.	Max.	Unit
V _{OH}	Output HIGH Voltage	V _{CC} = Min., I _{OH} = -4.0 mA	2.4	—	V
V _{OL}	Output LOW Voltage	V _{CC} = Min., I _{OL} = 8.0 mA	—	0.4	V
V _{IH}	Input HIGH Voltage		2.2	V _{CC} + 0.3	V
V _{IL}	Input LOW Voltage ⁽¹⁾		-0.3	0.8	V
I _{LI}	Input Leakage	GND ≤ V _{IN} ≤ V _{CC}	Com. Ind.	-1 5	1 5 μA
I _{LO}	Output Leakage	GND ≤ V _{OUT} ≤ V _{CC} , Outputs Disabled	Com. Ind.	-1 -5	1 5 μA

Notes:

1. V_{IL} = -3.0V for pulse width less than 10 ns.

POWER SUPPLY CHARACTERISTICS⁽¹⁾ (Over Operating Range)

Symbol	Parameter	Test Conditions		-8 ns		-10 ns		-12 ns		Unit
				Min.	Max.	Min.	Max.	Min.	Max.	
I _{CC1}	V _{CC} Operating Supply Current	V _{CC} = Max., $\overline{CE} = V_{IL}$	Com.	—	100	—	95	—	90	mA
		I _{OUT} = 0 mA, f = Max.	Ind.	—	110	—	105	—	100	
I _{SB}	TTL Standby Current (TTL Inputs)	V _{CC} = Max., V _{IN} = V _{IH} or V _{IL} $\overline{CE} \geq V_{IH}$, f = Max	Com. Ind.	—	35	—	30	—	25	mA
				—	40	—	35	—	30	
I _{SB1}	TTL Standby Current (TTL Inputs)	V _{CC} = Max., V _{IN} = V _{IH} or V _{IL} $\overline{CE} \geq V_{IH}$, f = 0	Com. Ind.	—	15	—	15	—	15	mA
				—	20	—	20	—	20	
I _{SB2}	CMOS Standby Current (CMOS Inputs)	V _{CC} = Max., $\overline{CE} \leq V_{CC} - 0.2V$, V _{IN} ≥ V _{CC} - 0.2V, or V _{IN} ≤ 0.2V, f = 0	Com. Ind.	—	1	—	1	—	1	mA
				—	1.5	—	1.5	—	1.5	

Notes:

- At f = f_{MAX}, address and data inputs are cycling at the maximum frequency, f = 0 means no input lines change.

CAPACITANCE^(1,2)

Symbol	Parameter	Conditions	Max.	Unit
C _{IN}	Input Capacitance	V _{IN} = 0V	6	pF
C _{I/O}	Input/Output Capacitance	V _{OUT} = 0V	8	pF

Notes:

- Tested initially and after any design or process changes that may affect these parameters.
- Test conditions: T_A = 25°C, f = 1 MHz, V_{CC} = 3.3V.

READ CYCLE SWITCHING CHARACTERISTICS⁽¹⁾ (Over Operating Range)

Symbol	Parameter	-8 ns		-10 ns		-12 ns		Unit
		Min.	Max.	Min.	Max.	Min.	Max.	
t _{RC}	Read Cycle Time	8	—	10	—	12	—	ns
t _{AA}	Address Access Time	—	8	—	10	—	12	ns
t _{OH}	Output Hold Time	2	—	2	—	2	—	ns
t _{ACE}	$\overline{\text{CE}}$ Access Time	—	8	—	10	—	12	ns
t _{DOE}	$\overline{\text{OE}}$ Access Time	—	4	—	5	—	6	ns
t _{LZOE⁽²⁾}	$\overline{\text{OE}}$ to Low-Z Output	0	—	0	—	0	—	ns
t _{HZOE⁽²⁾}	$\overline{\text{OE}}$ to High-Z Output	0	4	0	5	0	6	ns
t _{LZCE⁽²⁾}	$\overline{\text{CE}}$ to Low-Z Output	3	—	3	—	3	—	ns
t _{HZCE⁽²⁾}	$\overline{\text{CE}}$ to High-Z Output	0	4	0	5	0	6	ns
t _{PU}	$\overline{\text{CE}}$ to Power Up Time	0	—	0	—	0	—	ns
t _{PD}	$\overline{\text{CE}}$ to Power Down Time	—	8	—	10	—	12	ns

Notes:

- Test conditions assume signal transition times of 3 ns or less, timing reference levels of 1.5V, input pulse levels of 0 to 3.0V and C1 output loading specified in Figure 1.
- Tested with the C2 load in Figure 1. Transition is measured ± 500 mV from steady-state voltage. Not 100% tested.

AC TEST CONDITIONS

Parameter	Unit
Input Pulse Level	0V to 3.0V
Input Rise and Fall Times	3 ns
Input and Output Timing and Reference Levels	1.5V
Output Load	See Figures 1a and 1b

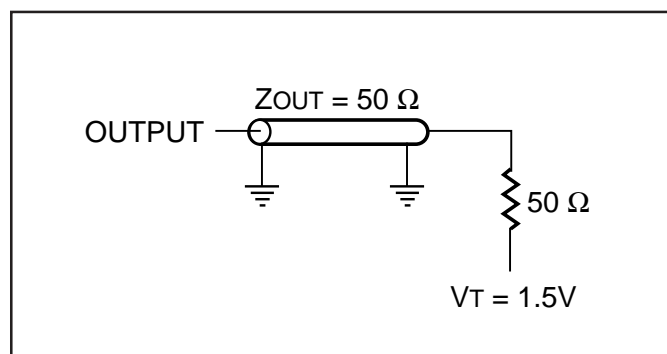
AC TEST LOADS

Figure 1

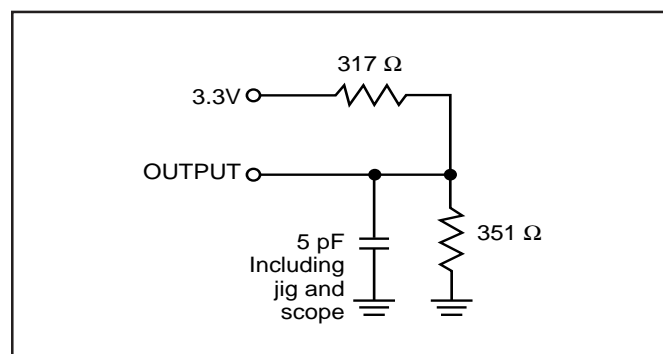
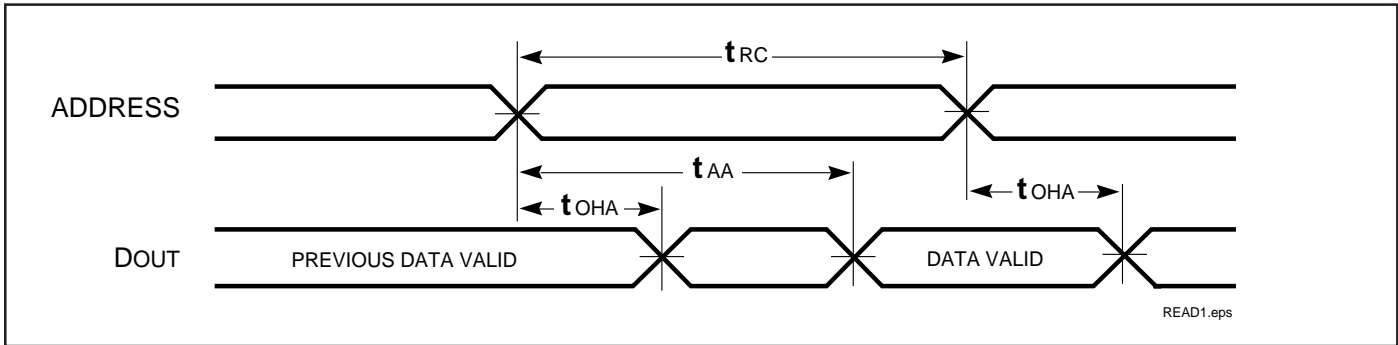


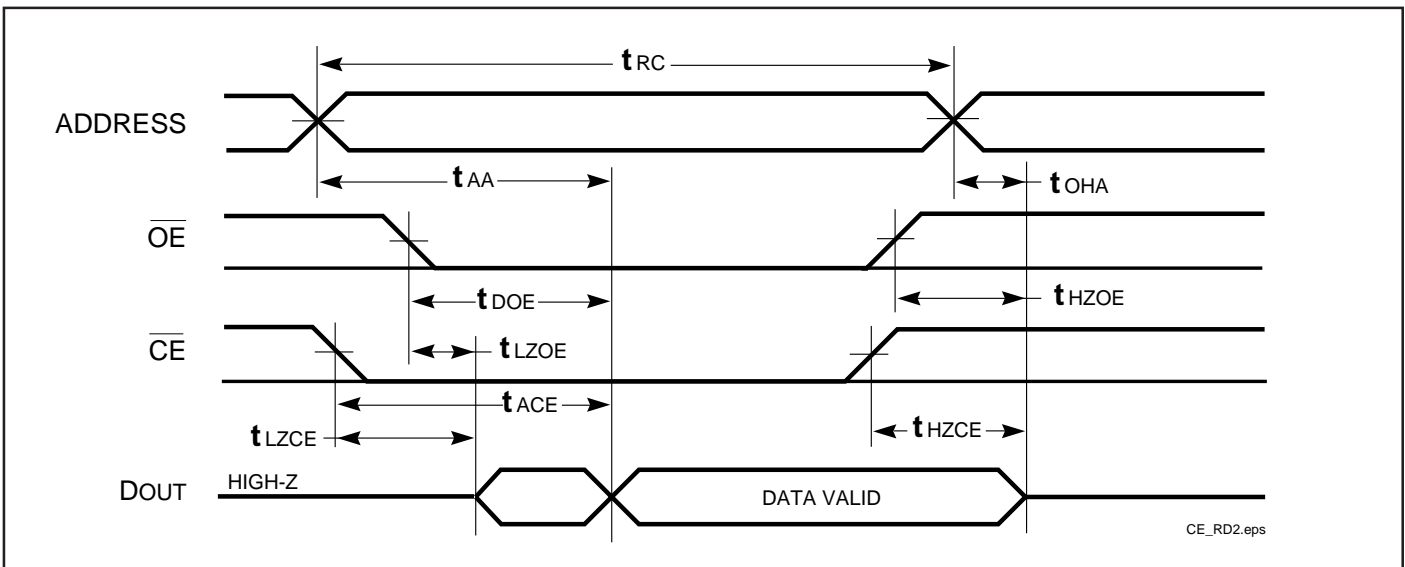
Figure 2

AC WAVEFORMS

READ CYCLE NO. 1^(1,2)



READ CYCLE NO. 2^(1,3)



Notes:

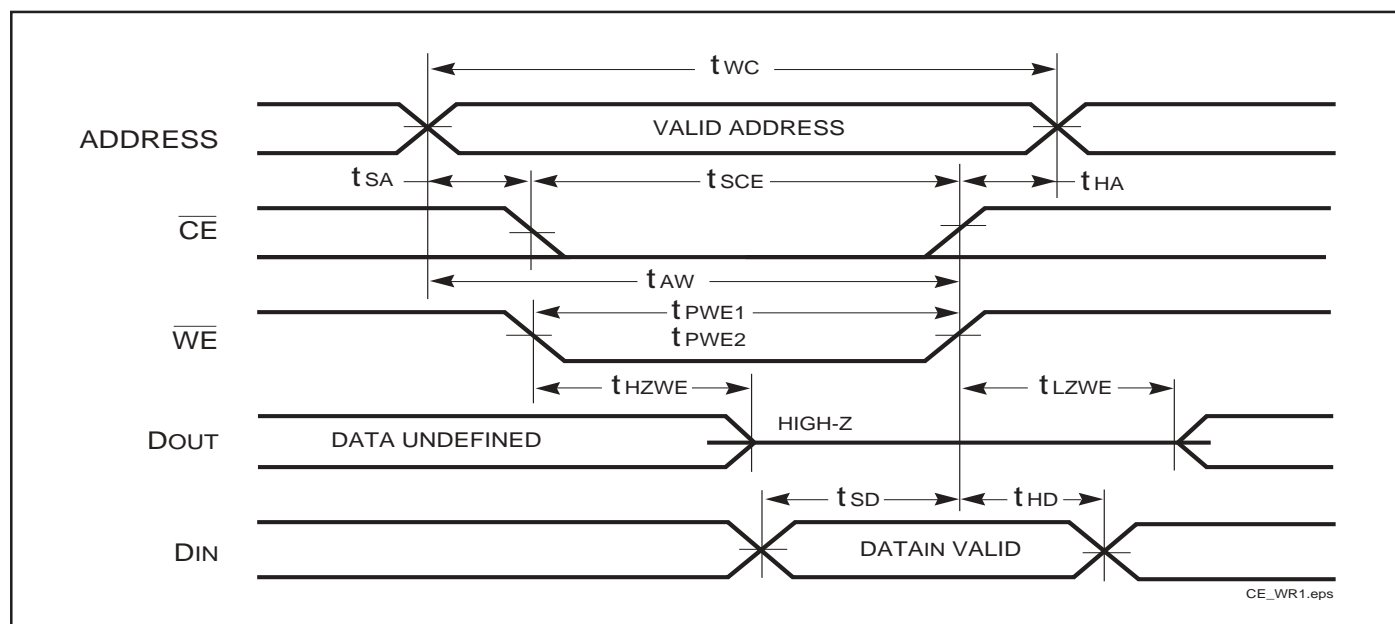
1. \overline{WE} is HIGH for a Read Cycle.
2. The device is continuously selected. \overline{OE} , $\overline{CE} = V_{IL}$.
3. Address is valid prior to or coincident with \overline{CE} LOW transitions.

WRITE CYCLE SWITCHING CHARACTERISTICS^(1,3) (Over Operating Range)

Symbol	Parameter	-8 ns		-10 ns		-12 ns		Unit
		Min.	Max.	Min.	Max.	Min.	Max.	
t _{WC}	Write Cycle Time	8	—	10	—	12	—	ns
t _{SCE}	\overline{CE} to Write End	7	—	7	—	8	—	ns
t _{AW}	Address Setup Time to Write End	8	—	8	—	8	—	ns
t _{HA}	Address Hold from Write End	0	—	0	—	0	—	ns
t _{SA}	Address Setup Time	0	—	0	—	0	—	ns
t _{PWE₁} ⁽¹⁾	\overline{WE} Pulse Width (\overline{OE} High)	7	—	7	—	8	—	ns
t _{PWE₂} ⁽²⁾	\overline{WE} Pulse Width (\overline{OE} Low)	8	—	10	—	12	—	ns
t _{SD}	Data Setup to Write End	5	—	5	—	6	—	ns
t _{HD}	Data Hold from Write End	0	—	0	—	0	—	ns
t _{HZWE} ⁽²⁾	\overline{WE} LOW to High-Z Output	—	4	—	5	—	6	ns
t _{LZWE} ⁽²⁾	\overline{WE} HIGH to Low-Z Output	3	—	3	—	3	—	ns

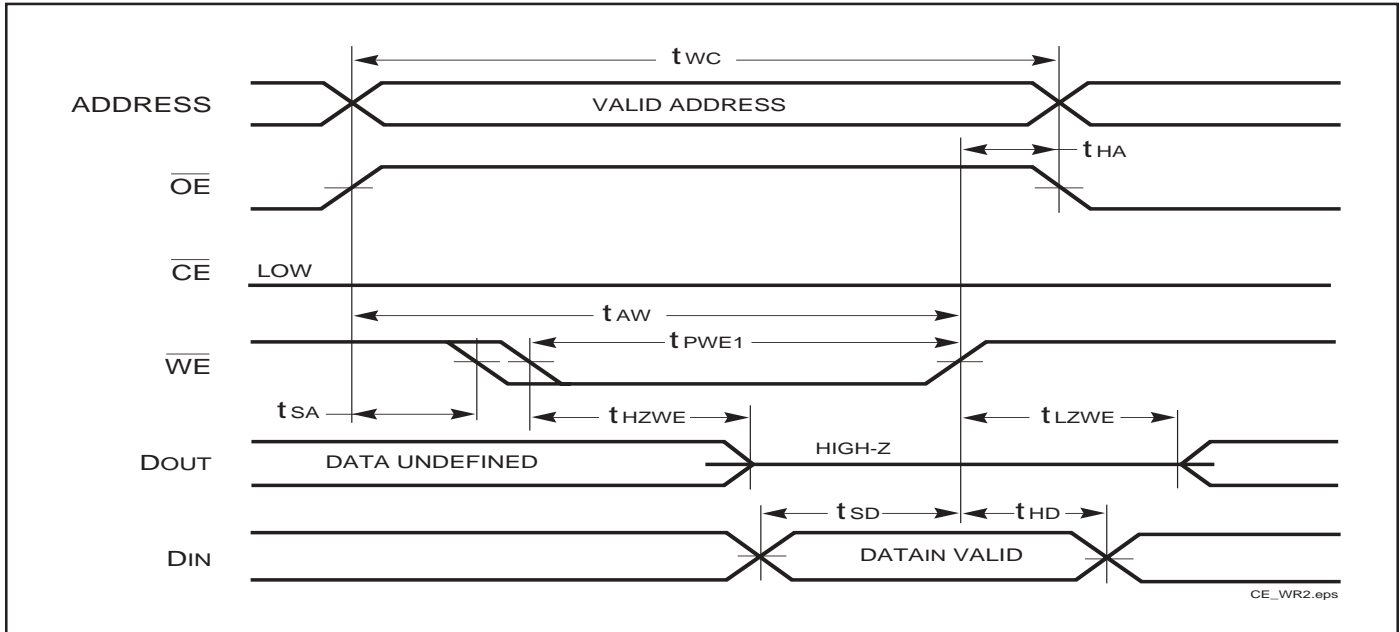
Notes:

1. Test conditions assume signal transition times of 3ns or less, timing reference levels of 1.5V, input pulse levels of 0 to 3.0V and output loading specified in Figure 1a.
2. Tested with the load in Figure 1b. Transition is measured ± 500 mV from steady-state voltage. Not 100% tested.
3. The internal write time is defined by the overlap of \overline{CE} LOW and \overline{WE} LOW. All signals must be in valid states to initiate a Write, but any one can go inactive to terminate the Write. The Data Input Setup and Hold timing are referenced to the rising or falling edge of the signal that terminates the Write.

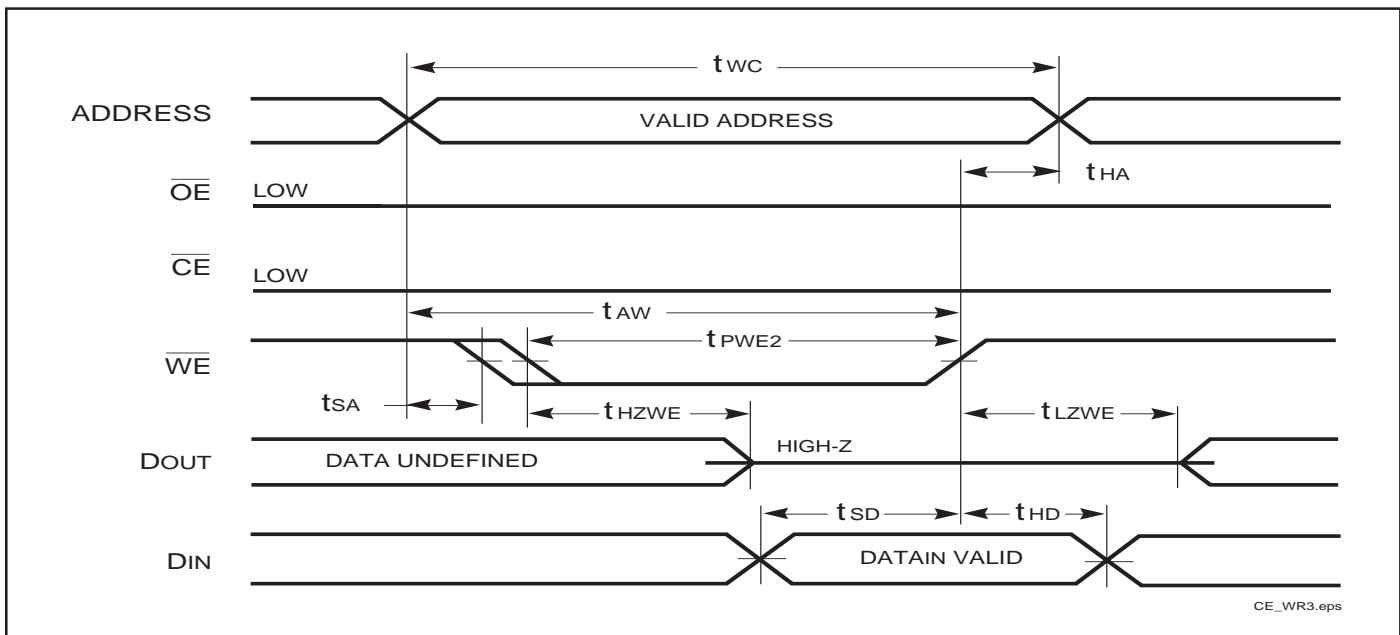
AC WAVEFORMS**WRITE CYCLE NO. 1^(1,2)** (\overline{CE} Controlled, \overline{OE} = HIGH or LOW)

AC WAVEFORMS

WRITE CYCLE NO. 2⁽¹⁾ (\overline{WE} Controlled, \overline{OE} = HIGH during Write Cycle)



WRITE CYCLE NO. 3 (\overline{WE} Controlled: \overline{OE} is LOW During Write Cycle)



Notes:

1. The internal write time is defined by the overlap of \overline{CE} LOW and \overline{WE} LOW. All signals must be in valid states to initiate a Write, but any one can go inactive to terminate the Write. The Data Input Setup and Hold timing are referenced to the rising or falling edge of the signal that terminates the Write.
2. I/O will assume the High-Z state if $\overline{OE} \cdot V_{IH}$.

IS63LV1024L

ORDERING INFORMATION

Commercial Range: 0°C to +70°C

Speed (ns)	Order Part No.	Package
8	IS63LV1024L-8T	TSOP (Type II)
	IS63LV1024L-8H	STSOP (Type I) (8mm x13.4mm)
	IS63LV1024L-8J	300-mil Plastic SOJ
	IS63LV1024L-8K	400-mil Plastic SOJ
	IS63LV1024L-8B	mBGA(8mmx10mm)
10	IS63LV1024L-10T	TSOP (Type II)
	IS63LV1024L-10J	300-mil Plastic SOJ
	IS63LV1024L-10K	400-mil Plastic SOJ
	IS63LV1024L-10B	mBGA(8mmx10mm)
12	IS63LV1024L-12T	TSOP (Type II)
	IS63LV1024L-12H	STSOP (Type I) (8mm x13.4mm)
	IS63LV1024L-12J	300-mil Plastic SOJ
	IS63LV1024L-12K	400-mil Plastic SOJ
	IS63LV1024L-12B	mBGA(8mmx10mm)

Industrial Range: -40°C to +85°C

Speed (ns)	Order Part No.	Package
8	IS63LV1024L-8TI	TSOP (Type II)
	IS63LV1024L-8JI	300-mil Plastic SOJ
	IS63LV1024L-8KI	400-mil Plastic SOJ
	IS63LV1024L-8BI	mBGA(8mmx10mm)
10	IS63LV1024L-10TI	TSOP (Type II)
	IS63LV1024L-10HI	STSOP (Type I) (8mm x13.4mm)
	IS63LV1024L-10JI	300-mil Plastic SOJ
	IS63LV1024L-10KI	400-mil Plastic SOJ
	IS63LV1024L-10BI	mBGA(8mmx10mm)
12	IS63LV1024L-12TI	TSOP (Type II)
	IS63LV1024L-12JI	300-mil Plastic SOJ
	IS63LV1024L-12KI	400-mil Plastic SOJ
	IS63LV1024L-12BI	mBGA(8mmx10mm)