



February 2005

LM2753 High Power Switched Capacitor Voltage Converter/Flash LED Driver

General Description

The LM2753 is capable of driving a Flash LED with a pulsed current of 400mA at an input voltage of 3.6V. A switched capacitor doubler, the LM2753 provides a regulated 5V output (V_{OUT}) over an input supply range of 3.0V to 5.5V. The switched output, I_{OUT} , takes less than 10ns to turn on and provide maximum current to a Flash LED. Flash LED current is set via a ballast resistor. Continuous illumination current (Torch Mode) is programmed by connecting a resistor between I_{OUT} and V_{OUT} . This device uses only three small, low-cost ceramic capacitors.

LM2753 uses Pulse Frequency Modulation (PFM) regulation. Typical operating frequency is 725kHz. Under no-load conditions, LM2753 operates on only 60µA. If the output is connected to ground, the charge pump stays in the gain of 1 which helps limit the input current to 300mA (typ.)

LM2753 is available in a 10-pin No Pullback Leadless Leadframe Package: LLP-10.

Features

- Input Voltage Range: 3.0V to 5.5V
- Regulated 5V Output
- 250mA Output Current with a 3.6V input
- 400mA Pulsed Output Current (up to 500ms duration)
- 60µA (typ.) Quiescent Current
- PFM Regulation
- Inductor-less solution: requires only 3 small capacitors
- <1µA Typical Shutdown Current
- 10-pin LLP Package (No Pullback): 3mm x 3mm x 0.75mm

Applications

- Cell Phone Camera Flash
- General Purpose Regulated Voltage Output, High Current Supply

Typical Application Circuit

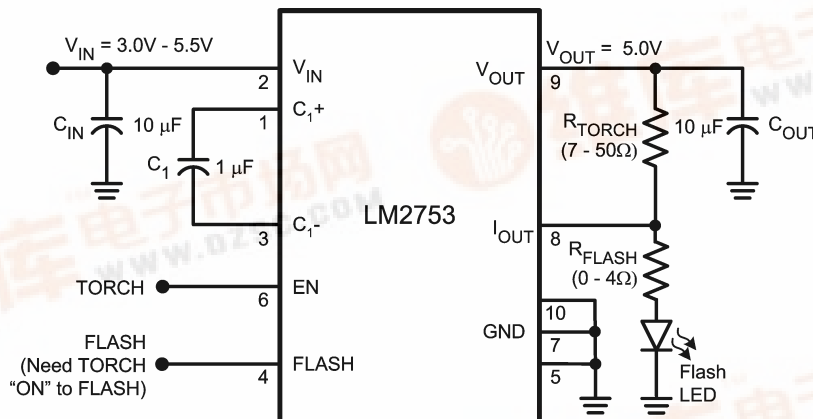

20140601

LM2753 High Power Switched Capacitor Voltage Converter/Flash LED Driver



Connection Diagram

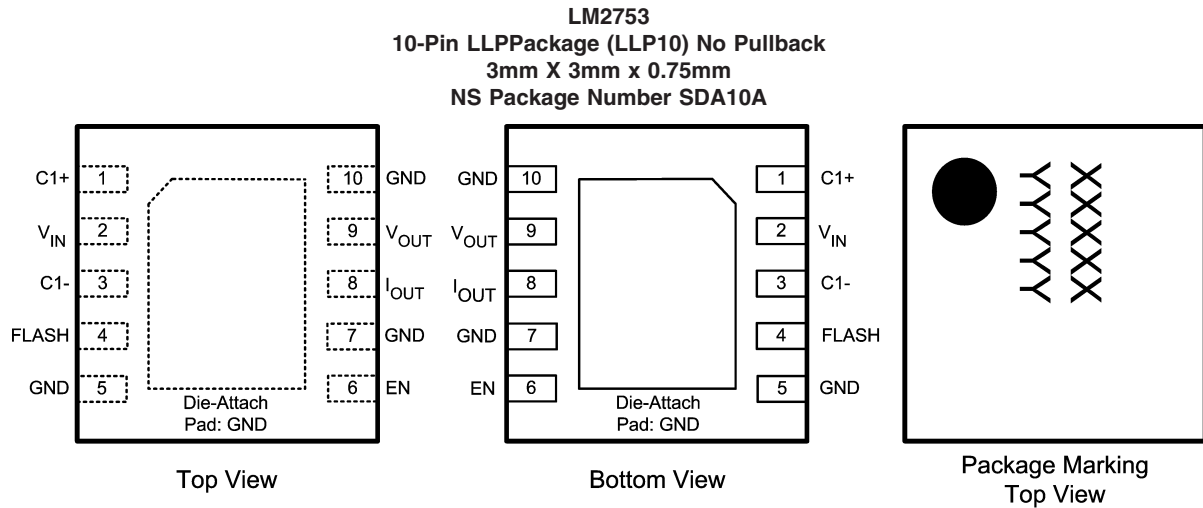

Note: The actual physical placement of the package marking will vary from part to part. The package marking placeholder "XXXXX" is a code for die traceability. "YYYYY" identifies the device (part number, voltage option, etc.). See the Order Information table below for the device ID codes.

20140605

Pin Descriptions

| Pin # | Name | Description |
|-------|-----------|--|
| 1 | C_{1+} | Flying capacitor connection. |
| 2 | V_{IN} | Input Voltage Connection. Input Voltage Range: 3.0V to 5.5V. |
| 3 | C_{1-} | Flying Capacitor connection. |
| 4 | FLASH | Flash Logic Input Pin. Logic HIGH = Flash Output On, Logic LOW = Flash Output Off. There is an internal pulldown of 300k Ω between FLASH and GND. |
| 5 | GND | Connect to Ground. |
| 6 | EN | Enable Pin. Logic HIGH = Enable, Logic LOW = Shut Down. There is an internal pulldown of 300k Ω between EN and GND |
| 7 | GND | Connect to Ground. |
| 8 | I_{OUT} | Flash Output. On/Off Control via FLASH Pin. |
| 9 | V_{OUT} | 5V Regulated Output. |
| 10 | GND | Connect to Ground |

Ordering Information

| Output Voltage | Ordering Number | Package Mark ID | Package | Supplied As |
|----------------|-----------------|-----------------|------------------------|---------------------------|
| 5.0V | LM2753SD | D004B | SDA10A Non-Pullback | 250 Units, Tape and Reel |
| 5.0V | LM2753SDX | D004B | LLP | 3000 Units, Tape and Reel |

Absolute Maximum Ratings (Notes 1, 2)

If Military/Aerospace specified devices are required, please contact the National Semiconductor Sales Office/Distributors for availability and specifications. If Military/Aerospace specified devices are required, please contact the National semiconductor Sales/Office/Distributors for availability and specifications.

| | |
|--|--|
| V_{IN} Pin: Voltage to Ground | -0.3V to 6.0V |
| EN, Flash pins: Voltage to GND | -0.3V to ($V_{IN}+0.3$) w/ 6.0V max |
| Continuous Power Dissipation (Note 3) | Internally Limited |
| Junction Temperature ($T_{J-MAX-ABS}$) | 150°C |
| Storage Temperature Range | -65°C to 150°C |
| Maximum Lead Temperature (Soldering, 10sec.) | 265°C |
| ESD Rating (Note 4) | |
| Human-body model: | 2kV |
| Machine model: | 200V |

Electrical Characteristics (Notes 2, 7)

Limits in standard typeface are for $T_A = 25^\circ\text{C}$. Limits in **boldface** type apply over the full operating ambient temperature range ($-40^\circ\text{C} \leq T_A \leq +85^\circ\text{C}$). Unless otherwise noted, specifications apply to the LM2753 Typical Application Circuit (pg. 1) with: $V_{IN} = 3.6\text{V}$, $V(\text{EN}) = V_{IN}$, $V(\text{FLASH}) = \text{GND}$, $C_1 = 1.0\mu\text{F}$, $C_{IN} = C_{OUT} = 10.0\mu\text{F}$ (Note 8).

| Symbol | Parameter | Conditions | Min | Typ | Max | Units |
|-------------|------------------------------|--|-----------------------------|-----|-----------------------------|---------------|
| V_{OUT} | Output Voltage | $3.0\text{V} \leq V_{IN} \leq 5.5\text{V}$, $I_{OUT} \leq 100\text{mA}$ | 4.75 (-5%) | 5.0 | 5.25 (+5%) | V |
| I_{VOUT} | Continuous Load Current | $3.0\text{V} \leq V_{IN} \leq 5.5\text{V}$ $V_{OUT} = 5\text{V}$ (typ.) | | 200 | | mA |
| I_{OUT} | Pulsed Flash Current | $V(\text{FLASH}) = 1.8\text{V}$ $T_{PULSE} = 500\text{mS}$ $V_{IOUT-MAX} = 4.1\text{V}$ (typ.) | | 400 | | mA |
| I_Q | Quiescent Current | $I_{OUT} = 0\text{mA}$ $3.0\text{V} \leq V_{IN} \leq 5.5\text{V}$ | | 60 | 80 | μA |
| I_{SD} | Shutdown Supply Current | $V(\text{EN}) = 0\text{V}$ $3.0\text{V} \leq V_{IN} \leq 5.5\text{V}$ | | 0.1 | 1 | μA |
| | | $V(\text{EN}) = 0\text{V}$ $3.0\text{V} \leq V_{IN} \leq 5.5\text{V}$ $T_A = 85^\circ\text{C}$ | | 0.2 | | |
| R_{OUT} | Output Impedance | $V_{IN} = 3.2\text{V}$ | | 5.3 | | Ω |
| fsw | Switching Frequency | $3.0\text{V} \leq V_{IN} \leq 5.5\text{V}$ | 475 | 725 | 950 | kHz |
| V_{IH} | Logic Input High | Input Pins: EN, FLASH | 1.20 | | V_{IN} | V |
| V_{IL} | Logic Input Low | Input Pins: EN, FLASH | 0 | | .30 | V |
| I_{IH} | Logic Input High Current | $V(\text{EN}) = V(\text{FLASH}) = 3.0\text{V}$ | | 10 | | μA |
| I_{IL} | Logic Input Low Current | $V(\text{EN}) = V(\text{FLASH}) = 0\text{V}$ | | 10 | | nA |
| t_{ON} | Turn-On Time (Note 9) | | | 640 | | μs |
| t_{FLASH} | Flash Turn-On Time (Note 10) | $V(\text{FLASH}) = 3.6\text{V}$ | | 10 | | ns |

Note 1: Absolute Maximum Ratings indicate limits beyond which damage to the component may occur. Operating Ratings are conditions under which operation of the device is guaranteed. Operating Ratings do not imply guaranteed performance limits. For guaranteed performance limits and associated test conditions, see the Electrical Characteristics tables.

Note 2: All voltages are with respect to the potential at the GND pin.

Note 3: Internal thermal shutdown circuitry protects the device from permanent damage. Thermal shutdown engages at $T_J = 125^\circ\text{C}$ (typ.).

Note 4: The Human body model is a 100 pF capacitor discharged through a 1.5 k Ω resistor into each pin. The machine model is a 200pF capacitor discharged directly into each pin. MIL-STD-883 3015.7

Operating Ratings (Notes 1, 2)

| | |
|--------------------------------------|----------------|
| Input Voltage Range | 3.0V to 5.5V |
| EN, Flash Input Voltage Range | 0V to V_{IN} |
| Junction Temperature (T_J) Range | -40°C to 120°C |
| Ambient Temperature (T_A) Range | -40°C to 85°C |
| (Note 5) | |

Thermal Properties

| | |
|--|--------|
| Junction-to-Ambient Thermal Resistance, LLP-10 | 55°C/W |
| Package (θ_{JA}) (Note 6) | |

Electrical Characteristics (Notes 2, 7) (Continued)

Note 5: In applications where high power dissipation and/or poor package thermal resistance is present, the maximum ambient temperature may have to be derated. Maximum ambient temperature (T_{A-MAX}) is dependent on the maximum operating junction temperature ($T_{J-MAX-OP} = 120^{\circ}\text{C}$), the maximum power dissipation of the device in the application (P_{D-MAX}), and the junction-to ambient thermal resistance of the part/package in the application (θ_{JA}), as given by the following equation: $T_{A-MAX} = T_{J-MAX-OP} - (\theta_{JA} \times P_{D-MAX})$.

Note 6: Junction-to-ambient thermal resistance (θ_{JA}) is taken from a thermal modeling result, performed under the conditions and guidelines set forth in the JEDEC standard JESD51-7. The test board is a 4 layer FR-4 board measuring 102mm x 76mm x 1.6mm with a 2 x 1 array of thermal vias. The ground plane on the board is 50mm x 50mm. Thickness of copper layers are 36 μm /18 μm /18 μm /36 μm (1.5oz/1oz/1oz/1.5oz). Ambient temperature in simulation is 22 $^{\circ}\text{C}$, still air. Power dissipation is 1W.

The value of θ_{JA} of the LM2753 in LLP-10 could fall in a range as wide as 50 $^{\circ}\text{C}/\text{W}$ to 150 $^{\circ}\text{C}/\text{W}$ (if not wider), depending on PWB material, layout, and environmental conditions. In applications where high maximum power dissipation exists (high V_{IN} , high I_{OUT}), special care must be paid to thermal dissipation issues. For more information on these topics, please refer to **Application Note 1187: Leadless Leadframe Package (LLP)** and the **Power Efficiency and Power Dissipation** section of this datasheet.

Note 7: Min and Max limits are guaranteed by design, test, or statistical analysis. Typical numbers are not guaranteed, but do represent the most likely norm.

Note 8: C_{IN} , C_{OUT} , and C_1 : Low-ESR Surface-Mount Ceramic Capacitors (MLCCs) used in setting electrical characteristics

Note 9: Turn-on time is measured from when the EN signal is pulled high until the output voltage on V_{OUT} crosses 90% of its final value.

Note 10: Flash Turn-on time is measured from when the FLASH signal is pulled high until the voltage on I_{OUT} crosses 90% of its final programmed value.

Block Diagram

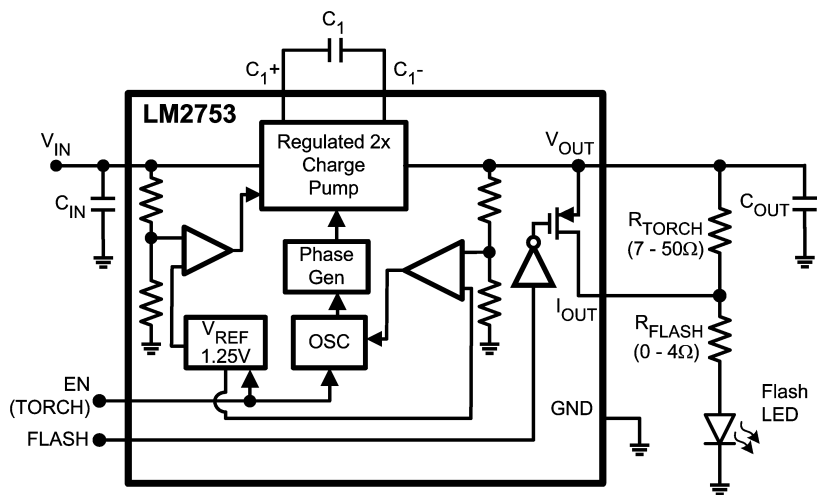

20140606

Application Information

CIRCUIT DESCRIPTION

The LM2753 is a Switched Capacitor Doubler with a regulated 5V output. It is capable of continuously supplying up to 200mA at 5V to a load connected to V_{OUT} . This device uses Pulse Frequency Modulation and a Multi-Level Switch Array to regulate and maintain the output voltage. For higher load currents, such as during Flash operation, the output voltage is allowed to droop to supply the necessary current. Although there is no current limit on this device, the device will automatically default to a gain of 1 when the output is brought below the input voltage. This configuration limits the input current to about 300mA (typ.). The operating range for the LM2753 is over the extended Li-Ion battery range from 2.7V to 5.5V.

Aside from powering Flash LEDs, the LM2753 is suitable for driving other devices with power requirements up to 200mA. White LEDs can also be connected to this device to backlight a cellular phone keypad and display. The LED brightness can be controlled by applying a PWM (Pulse Width Modulation) signal to the Enable pin (EN) during "Torch" mode, or to the Flash pin during "Flash" mode. (see **PWM BRIGHTNESS CONTROL PROCEDURES** section).

SOFT START

Soft Start is engaged when the device is taken out of Shut-down mode (EN = logic HIGH) or when voltage is supplied simultaneously to the VIN and EN pins. During Soft Start, the voltage on V_{OUT} will ramp up in proportion to the rate that the reference voltage is being ramped up. The output voltage is programmed to rise from 0V to 5V in 640 μ s (typ.).

ENABLE MODE

The Enable logic pin (EN) disables the part and reduces the quiescent current to 0.1 μ A (typ.). The LM2753 has an active-high enable pin (LOW = shut down, HIGH = operating). The LM2753 EN pin can be driven with a low-voltage CMOS logic signal (1.5V logic, 1.8V logic, etc). There is an internal 300k Ω pull-down resistor between the EN and GND pins of the LM2753.

FLASH MODE

The Flash logic pin (Flash) controls the internal FET connected between the V_{OUT} and I_{OUT} pins on the LM2753. The LM2753 has an active-HIGH Flash pin (LOW = shut down, HIGH = operating). A logic HIGH signal must be present on the EN pin before a logic HIGH signal is placed on the Flash input pin. The EN and Flash input pins can be connected together and controlled with the same logic signal. The turn-on time for I_{OUT} in this configuration will be limited by the turn-on time of the device. The turn-on time for the internal FET is typically 10ns when the device is already on (EN signal HIGH, V_{OUT} at 5V). The LM2753 Flash pin can be driven with a low-voltage CMOS logic signal (1.5V logic, 1.8V logic, etc). There is an internal 300k Ω pull-down resistor between the Flash and GND pins of the LM2753.

CAPACITOR SELECTION

The LM2753 requires 3 external capacitors for proper operation. Surface-mount multi-layer ceramic capacitors are recommended. These capacitors are small, inexpensive and have very low equivalent series resistance (ESR, ≤ 15 m Ω typ.). Tantalum capacitors, OS-CON capacitors, and alumi-

num electrolytic capacitors are generally not recommended for use with the LM2753 due to their high ESR, as compared to ceramic capacitors.

For most applications, ceramic capacitors with X7R or X5R temperature characteristic are preferred for use with the LM2753. These capacitors have tight capacitance tolerance (as good as $\pm 10\%$), hold their value over temperature (X7R: $\pm 15\%$ over -55°C to 125°C ; X5R: $\pm 15\%$ over -55°C to 85°C), and typically have little voltage coefficient when compared to other types of capacitors. However selecting a capacitor with a voltage rating much higher than the voltage it will be subjected to, will ensure that the capacitance will stay closer to the capacitor's nominal value. Capacitors with Y5V or Z5U temperature characteristic are generally not recommended for use with the LM2753. Capacitors with these temperature characteristics typically have wide capacitance tolerance ($+80\%$, -20%), vary significantly over temperature (Y5V: $+22\%$, -82% over -30°C to $+85^{\circ}\text{C}$ range; Z5U: $+22\%$, -56% over $+10^{\circ}\text{C}$ to $+85^{\circ}\text{C}$ range), and have poor voltage coefficients. Under some conditions, a nominal 1 μ F Y5V or Z5U capacitor could have a capacitance of only 0.1 μ F. Such detrimental deviation is likely to cause Y5V and Z5U capacitors to fail to meet the minimum capacitance requirements of the LM2753. *Table 1* lists suggested capacitor suppliers for the typical application circuit.

TABLE 1. Ceramic Capacitor Manufacturers

| Manufacturer | Contact |
|--------------|--|
| TDK | www.component.tdk.com |
| Murata | www.murata.com |
| Taiyo Yuden | www.t-yuden.com |

FLASH LED SELECTION

The LM2753 provides a 5V (typ.) fixed voltage to drive a Flash LED with a continuous current up to 200mA (typ.). At LED currents above 200mA (typ.), the output of the LM2753 is allowed to droop to deliver the desired current to the Flash LED. This droop limits the maximum forward voltage and in turn the maximum current that can be supplied to a given LED. LEDs should be chosen such that the LED forward voltage at the desired maximum LED current does not exceed the output voltage of the LM2753 when loaded down with that same current. It is suggested that the selected LEDs be binned due to the relatively high forward voltage tolerance of Flash LEDs. The typical and maximum diode forward voltage depends highly on the manufacturer and their technology. *Table 2* lists several suggested manufacturers.

TABLE 2. Flash LED Selection

| Manufacturer | Contact |
|---------------------|--|
| Agilent | www.agilent.com/semiconductors |
| AOT | www.aot.com.tw |
| Citizen | www.c-e.co.jp/e/ |
| Lumiled | www.lumileds.com |
| Nichia | www.nichia.com |
| Osram | www.osram-os.com |
| Panasonic | www.panasonic.co.jp/semicon/ |
| Seoul Semiconductor | en.seoulsemicon.co.kr |

Application Information (Continued)

PFM REGULATION

The LM2753 achieves its tightly regulated output voltage with pulse-frequency modulated (PFM) regulation. PFM simply means the part only pumps when charge needs to be delivered to the output in order to keep the output voltage in regulation. When the output voltage is above the target regulation voltage the part idles, consuming minimal supply current with C_1 is connected between V_{IN} and GND and V_{IN} is disconnected from V_{OUT} . In this state, the load current is supplied solely by the charge stored on the output capacitor. As this capacitor discharges and the output voltage falls below the target regulation voltage, the charge pump activates, and charge is delivered to the output. This charge supplies the load current and boosts the voltage on the output capacitor.

The primary benefit of PFM regulation is when output currents are light and the part is predominantly in the low-supply-current idle state. Net supply current is minimal because the part only occasionally needs to recharge the output capacitor by activating the charge pump. With PFM regulation, input and output ripple frequencies vary significantly, and are dependent on output current, input voltage, and to a lesser degree, other factors such as temperature, internal switch characteristics, and capacitor characteristics (voltage tolerance, temperature variation).

OUTPUT VOLTAGE RIPPLE

The voltage ripple on the output of the LM2753 is highly dependent on the application conditions. The output capacitance, input voltage, and output current each play a significant part in determining the output voltage ripple. Due to the complexity of the LM2753 operation, providing equations or models to approximate the magnitude of the ripple cannot be easily accomplished. However, the following general statements can be made.

The output capacitor will have a significant effect on output voltage ripple magnitude. Ripple magnitude will typically be linearly proportional to the output capacitance present. The ESR of the output capacitor also contributes to the output voltage ripple, as there is effectively an AC voltage drop across the ESR due to current switching in and out of the capacitor. To keep the voltage ripple small, a low-ESR ceramic capacitor is recommended on the output. Placing multiple capacitors in parallel can reduce ripple significantly, by both increasing capacitance and reducing ESR. When capacitors are in parallel the ESR of the capacitors are in parallel as well, resulting in a net ESR according to the properties of parallel resistance. Two identical capacitors in parallel have twice the capacitance and half the ESR as compared to a single capacitor if the same type. On a similar note, if a large-value, high-ESR capacitor (tantalum, for example) is to be used as the primary output capacitor, the net ESR can be significantly reduced by placing a low-ESR ceramic capacitor in parallel with this primary output capacitor.

I_{OUT} PIN

An internal FET is connected between the V_{OUT} pin and the I_{OUT} pin of the LM2753. When a logic high signal is placed on the Flash input pin, the internal FET turns on and connects I_{OUT} to V_{OUT} in less than 10ns (typ). If the I_{OUT} pin is not going to be used, the Flash input pin can be tied to GND and the I_{OUT} pin can be left unconnected.

In the typical application circuit there is one resistor between V_{OUT} and I_{OUT} and another resistor between I_{OUT} and the Flash LED. When a LOW logic signal is placed on the Flash input pin, the internal FET opens and current flows from V_{OUT} through both resistors and through the Flash LED. When a logic HIGH signal is applied to the Flash input pin the internal FET closes, shorting out the resistor between V_{OUT} and I_{OUT} , and current flows through the second resistor and the Flash LED.

Follow the steps below to set the desired current levels for the Flash LED:

Setting Flash Current

1. Determine the LED's forward voltage at the desired Flash current.
2. Find the voltage difference between I_{OUT} and the LED forward voltage.
3. Divide the voltage difference by the desired Flash current to obtain the needed Flash LED ballast resistance

Setting Torch Current

1. First determine required Flash Ballast
2. Determine the LED's forward voltage at the desired continuous Torch current
3. Find the voltage difference between V_{OUT} and the LED forward voltage.
4. Divide the voltage difference by the desired Torch current to obtain the total resistance needed.
5. Subtract the Flash Ballast resistance from this total resistance to find the required Torch resistance between V_{OUT} and I_{OUT}

PWM BRIGHTNESS CONTROL PROCEDURES

The brightness of a Flash LED connected to V_{OUT} can be linearly varied from zero up to the maximum programmed current level by applying a Pulse-Width-Modulated signal to the EN pin of the LM2753. The following procedures illustrate how to program the LED drive current and adjust the output current level using a PWM signal.

1. To select the maximum desired current level, refer to the "I_{OUT} Pin" section and follow the steps detailed in the "Setting Flash Current" and "Setting Torch Current" sub-headings.
2. Brightness control for "Torch" mode can be implemented by pulsing a signal at the EN pin, while Flash is connected to a logic LOW signal. Also, brightness control can also be implemented for Flash mode by pulsing a signal on the Flash pin while the part is already enabled (EN = logic HIGH). LED brightness is proportional to the duty cycle (D) of the PWM signal. For linear brightness control over the full duty cycle adjustment range, the PWM frequency (f) should be limited during Torch mode to accommodate the turn-on time ($T_{ON} = 640\mu s$) of the device. Also, the PWM frequency should be limited during "Flash" mode to accommodate the turn-on time ($T_{FLASH} = 10ns$) of the I_{OUT} output FET.

$$D \times (1/f) > T_{ON,FLASH}$$

$$f_{MAX} = D_{MIN} \div T_{ON,FLASH}$$

If the PWM frequency is much less than 100Hz, flicker may be seen in the LEDs. For the LM2753, zero duty cycle will turn off the LED and a 50% duty cycle will result in an average I_{OUT} being half of the programmed LED current. For example, if the output is programmed for a maximum of 100mA through the Flash LED, a 50% duty cycle will result in an average I_{LED} of 50mA.

Application Information (Continued)

MULTI-LEVEL SWITCH ARRAY.

In order to supply high load currents across the entire V_{IN} operating range, especially at lower V_{IN} , switches in the charge pump are normally designed to have low on-resistance. However at high input voltages and low load currents, this low resistance results in high output voltage ripple due to the output capacitor being charged too quickly. To solve this problem, while still being able to deliver the needed output current, the LM2753 has a switch array with multiple switches connected in parallel.

The number of switches used in parallel depends on the input voltage applied to the LM2753. At lower input voltages all paralleled switches are used, and as the input voltage rises, switches are removed from the parallel configuration. The highest switch resistance is achieved as the input voltage reaches the maximum operating voltage, which helps with voltage management.

THERMAL PROTECTION

When the junction temperature exceeds 140°C (typ.), the LM2753 internal thermal protection circuitry disables the part. This feature protects the device from damage due to excessive power dissipation. The device will recover and operate normally when the junction temperature falls below 125°C (typ.). It is important to have good thermal conduction with a proper layout to reduce thermal resistance.

POWER EFFICIENCY

Charge-Pump efficiency is derived in the following two ideal equations (supply current and other losses are neglected for simplicity):

$$I_{IN} = G \times I_{OUT}$$

$$E = (V_{OUT} \times I_{OUT}) \div (V_{IN} \times I_{IN}) = V_{OUT} \div (G \times V_{IN})$$

In the equations, G represents the charge pump gain. Efficiency is at its highest as $G \times V_{IN}$ approaches V_{OUT} . Refer to the efficiency graph in the **Typical Performance Characteristics** section for the detailed efficiency data.

POWER DISSIPATION

The power dissipation ($P_{DISSIPATION}$) and junction temperature (T_J) can be approximated with the equations below. P_{IN} is the product of the input current and input voltage, P_{OUT} is the power consumed by the load connected to the output, T_A is the ambient temperature, and θ_{JA} is the junction-to-ambient thermal resistance for the LLP-10 package. V_{IN} is the input voltage to the LM2753, V_{VOUT} is the voltage at the output of the device, and I_{OUT} is the total current supplied to the load(s) connected to both V_{OUT} and I_{OUT} .

$$\begin{aligned} P_{DISSIPATION} &= P_{IN} - P_{OUT} \\ &= (V_{IN} \times I_{OUT}) - (V_{VOUT} \times I_{OUT}) \\ T_J &= T_A + (P_{DISSIPATION} \times \theta_{JA}) \end{aligned}$$

The junction temperature rating takes precedence over the ambient temperature rating. The LM2753 may be operated outside the ambient temperature rating, so long as the junction temperature of the device does not exceed the maximum operating rating of 120°C. The maximum ambient temperature rating must be derated in applications where high power dissipation and/or poor thermal resistance causes the junction temperature to exceed 120°C.

Physical Dimensions inches (millimeters) unless otherwise noted

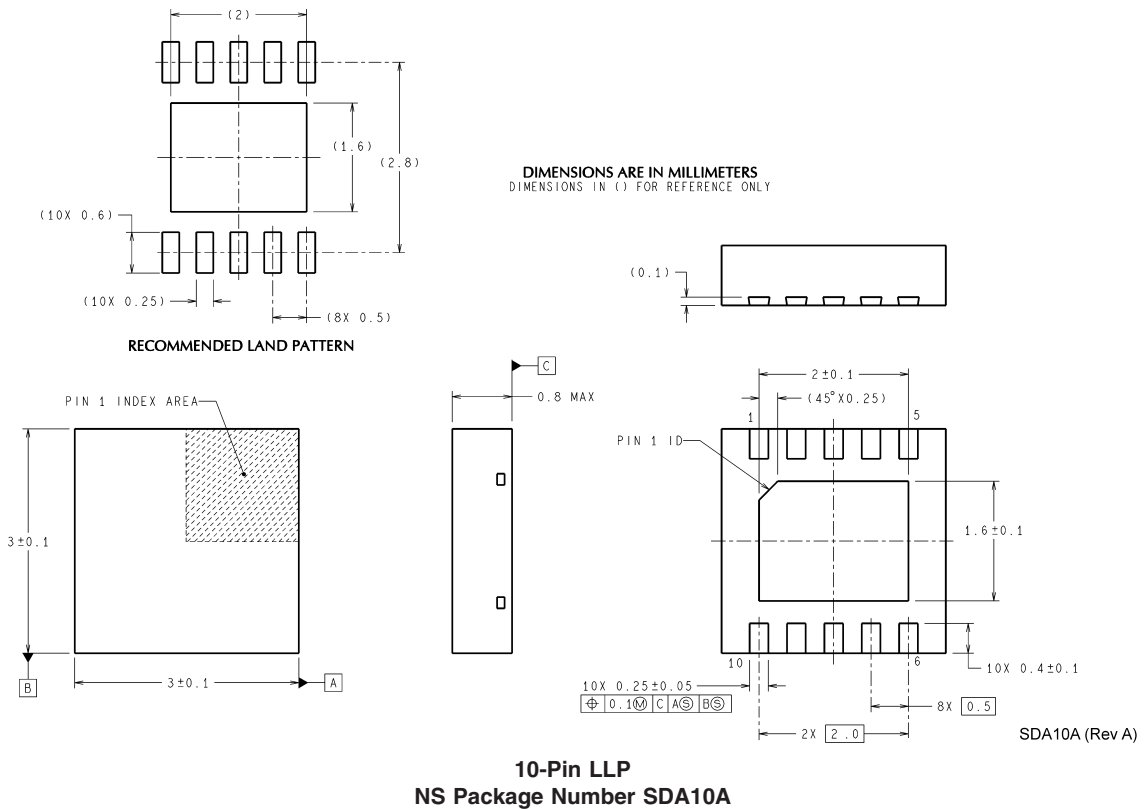

National does not assume any responsibility for use of any circuitry described, no circuit patent licenses are implied and National reserves the right at any time without notice to change said circuitry and specifications.

For the most current product information visit us at www.national.com.

LIFE SUPPORT POLICY

NATIONAL'S PRODUCTS ARE NOT AUTHORIZED FOR USE AS CRITICAL COMPONENTS IN LIFE SUPPORT DEVICES OR SYSTEMS WITHOUT THE EXPRESS WRITTEN APPROVAL OF THE PRESIDENT AND GENERAL COUNSEL OF NATIONAL SEMICONDUCTOR CORPORATION. As used herein:

1. Life support devices or systems are devices or systems which, (a) are intended for surgical implant into the body, or (b) support or sustain life, and whose failure to perform when properly used in accordance with instructions for use provided in the labeling, can be reasonably expected to result in a significant injury to the user.
2. A critical component is any component of a life support device or system whose failure to perform can be reasonably expected to cause the failure of the life support device or system, or to affect its safety or effectiveness.

BANNED SUBSTANCE COMPLIANCE

National Semiconductor manufactures products and uses packing materials that meet the provisions of the Customer Products Stewardship Specification (CSP-9-111C2) and the Banned Substances and Materials of Interest Specification (CSP-9-111S2) and contain no "Banned Substances" as defined in CSP-9-111S2.



**National Semiconductor
Americas Customer
Support Center**
Email: new.feedback@nsc.com
Tel: 1-800-272-9959

**National Semiconductor
Europe Customer Support Center**
Fax: +49 (0) 180-530 85 86
Email: europe.support@nsc.com
Deutsch Tel: +49 (0) 69 9508 6208
English Tel: +44 (0) 870 24 0 2171
Français Tel: +33 (0) 1 41 91 8790

**National Semiconductor
Asia Pacific Customer
Support Center**
Email: ap.support@nsc.com

**National Semiconductor
Japan Customer Support Center**
Fax: 81-3-5639-7507
Email: jpn.feedback@nsc.com
Tel: 81-3-5639-7560