

## Features

- Fast Read Access Time - 45 ns
- Low Power CMOS Operation
  - 100  $\mu$ A max. Standby
  - 30 mA max. Active at 5 MHz
- JEDEC Standard Packages
  - 40-Lead 600-mil PDIP
  - 44-Lead PLCC
  - 40-Lead TSOP (10 mm x 14 mm)
- Direct Upgrade from 512K (AT27C516) EPROM
- 5V  $\pm$  10% Power Supply
- High Reliability CMOS Technology
  - 2000V ESD Protection
  - 200 mA Latchup Immunity
- Rapid™ Programming Algorithm - 100  $\mu$ s/word (typical)
- CMOS and TTL Compatible Inputs and Outputs
- Integrated Product Identification Code
- Commercial and Industrial Temperature Ranges

## Description

The AT27C1024 is a low-power, high-performance 1,048,576 bit one-time programmable read only memory (OTP EPROM) organized 64K by 16 bits. It requires only one 5V power supply in normal read mode operation. Any word can be accessed in less than 45 ns, eliminating the need for speed reducing WAIT states. The by-16 organization make this part ideal for high-performance 16- and 32-bit microprocessor systems.

(continued)

## Pin Configurations

Pin Name	Function
A0 - A15	Addresses
O0 - O15	Outputs
CE	Chip Enable
OE	Output Enable
PGM	Program Strobe
NC	No Connect

Note: Both GND pins must be connected.

PDIP Top View

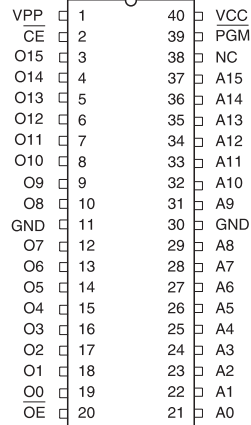

PLCC Top View

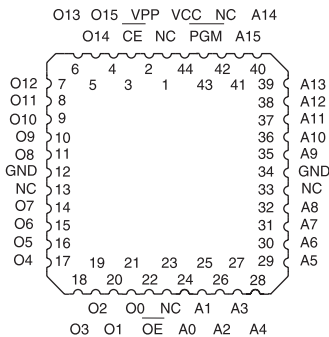

TSOP Top View  
Type 1

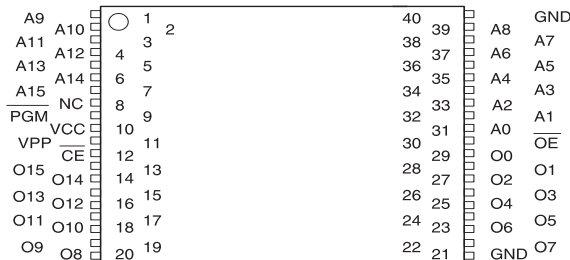

# 1-Megabit (64K x 16) OTP EPROM

## AT27C1024



In read mode, the AT27C1024 typically consumes 15 mA. Standby mode supply current is typically less than 10  $\mu$ A.

The AT27C1024 is available in industry standard JEDEC-approved one-time programmable (OTP) plastic PDIP, PLCC, and TSOP packages. The device features two-line control ( $\overline{CE}$ ,  $\overline{OE}$ ) to eliminate bus contention in high-speed systems.

With high density 64K word storage capability, the AT27C1024 allows firmware to be stored reliably and to be accessed by the system without the delays of mass storage media.

Atmel's 27C1024 have additional features to ensure high quality and efficient production use. The Rapid™ Programming Algorithm reduces the time required to program the part and guarantees reliable programming. Programming time is typically only 100  $\mu$ s/word. The Integrated Product Identification Code electronically identifies the device and manufacturer. This feature is used by industry standard programming equipment to select the proper programming algorithms and voltages.

## System Considerations

Switching between active and standby conditions via the Chip Enable pin may produce transient voltage excursions. Unless accommodated by the system design, these transients may exceed data sheet limits, resulting in device non-conformance. At a minimum, a 0.1  $\mu$ F high frequency, low inherent inductance, ceramic capacitor should be utilized for each device. This capacitor should be connected between the  $V_{CC}$  and Ground terminals of the device, as close to the device as possible. Additionally, to stabilize the supply voltage level on printed circuit boards with large EPROM arrays, a 4.7  $\mu$ F bulk electrolytic capacitor should be utilized, again connected between the  $V_{CC}$  and Ground terminals. This capacitor should be positioned as close as possible to the point where the power supply is connected to the array.

## Block Diagram

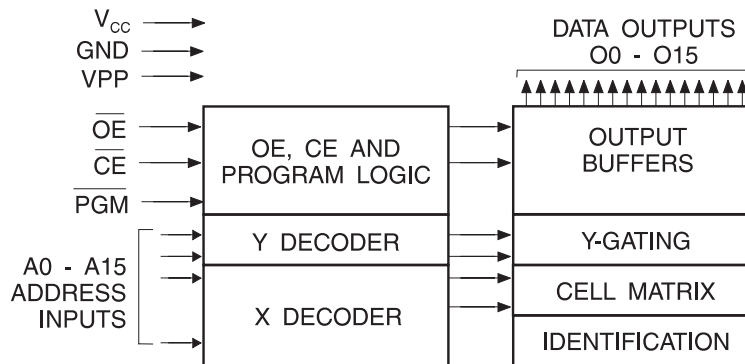

## Absolute Maximum Ratings\*

Temperature Under Bias .....	-55°C to +125°C
Storage Temperature.....	-65°C to +150°C
Voltage on Any Pin with Respect to Ground .....	-2.0V to +7.0V (1)
Voltage on A9 with Respect to Ground .....	-2.0V to +14.0V (1)
V <sub>PP</sub> Supply Voltage with Respect to Ground .....	-2.0V to +14.0V (1)

**\*NOTICE:** Stresses beyond those listed under “Absolute Maximum Ratings” may cause permanent damage to the device. This is a stress rating only and functional operation of the device at these or any other conditions beyond those indicated in the operational sections of this specification is not implied. Exposure to absolute maximum rating conditions for extended periods may affect device reliability.

**Note:** Minimum voltage is -0.6V DC which may undershoot to -2.0V for pulses of less than 20 ns. Maximum output pin voltage is V<sub>CC</sub> + 0.75V DC which may overshoot to +7.0V for pulses of less than 20 ns.

## Operating Modes

Mode/Pin	CE	OE	PGM	Ai	V <sub>PP</sub>	Outputs
Read	V <sub>IL</sub>	V <sub>IL</sub>	X <sup>(1)</sup>	Ai	X	D <sub>OUT</sub>
Output Disable	X	V <sub>IH</sub>	X	X	X	High Z
Standby	V <sub>IH</sub>	X	X	X	X <sup>(5)</sup>	High Z
Rapid Program <sup>(2)</sup>	V <sub>IL</sub>	V <sub>IH</sub>	V <sub>IL</sub>	Ai	V <sub>PP</sub>	D <sub>IN</sub>
PGM Verify	V <sub>IL</sub>	V <sub>IL</sub>	V <sub>IH</sub>	Ai	V <sub>PP</sub>	D <sub>OUT</sub>
PGM Inhibit	V <sub>IH</sub>	X	X	X	V <sub>PP</sub>	High Z
Product Identification <sup>(4)</sup>	V <sub>IL</sub>	V <sub>IL</sub>	X	A9 = V <sub>H</sub> <sup>(3)</sup> A0 = V <sub>IH</sub> or V <sub>IL</sub> A1 - A15 = V <sub>IL</sub>	V <sub>CC</sub>	Identification Code

- Notes:
1. X can be V<sub>IL</sub> or V<sub>IH</sub>.
  2. Refer to Programming Characteristics.
  3. V<sub>H</sub> = 12.0 ± 0.5V.
  4. Two identifier words may be selected. All Ai inputs are held low (V<sub>IL</sub>), except A9 which is set to V<sub>H</sub> and A0 which is toggled low (V<sub>IL</sub>) to select the Manufacturer's Identification word and high (V<sub>IH</sub>) to select the Device Code word.
  5. Standby V<sub>CC</sub> current (I<sub>SB</sub>) is specified with V<sub>PP</sub> = V<sub>CC</sub>. V<sub>CC</sub> > V<sub>PP</sub> will cause a slight increase in I<sub>SB</sub>.

## DC and AC Operating Conditions for Read Operation

		AT27C1024					
		-45	-55	-70	-90	-12	-15
Operating Temperature (Case)	Com.	0°C - 70°C	0°C - 70°C	0°C - 70°C	0°C - 70°C	0°C - 70°C	0°C - 70°C
	Ind.	-40°C - 85°C	-40°C - 85°C	-40°C - 85°C	-40°C - 85°C	-40°C - 85°C	-40°C - 85°C
V <sub>CC</sub> Power Supply		5V ± 10%	5V ± 10%	5V ± 10%	5V ± 10%	5V ± 10%	5V ± 10%

## DC and Operating Characteristics for Read Operation

Symbol	Parameter	Condition	Min	Max	Units
I <sub>LI</sub>	Input Load Current	V <sub>IN</sub> = 0V to V <sub>CC</sub>		± 1	μA
I <sub>LO</sub>	Output Leakage Current	V <sub>OUT</sub> = 0V to V <sub>CC</sub>		± 5	μA
IPP1 <sup>(2)</sup>	V <sub>PP</sub> <sup>(1)</sup> Read/Standby Current	V <sub>PP</sub> = V <sub>CC</sub>		10	μA
I <sub>SB</sub>	V <sub>CC</sub> <sup>(1)</sup> Standby Current	I <sub>SB1</sub> (CMOS), $\overline{CE} = V_{CC} \pm 0.3V$		100	μA
		I <sub>SB2</sub> (TTL), $\overline{CE} = 2.0$ to V <sub>CC</sub> + 0.5V		1	mA
I <sub>CC</sub>	V <sub>CC</sub> Active Current	f = 5 MHz, I <sub>OUT</sub> = 0 mA, $\overline{CE} = V_{IL}$		30	mA
V <sub>IL</sub>	Input Low Voltage		-0.6	0.8	V
V <sub>IH</sub>	Input High Voltage		2.0	V <sub>CC</sub> + 0.5	V
V <sub>OL</sub>	Output Low Voltage	I <sub>OL</sub> = 2.1 mA		0.4	V
V <sub>OH</sub>	Output High Voltage	I <sub>OH</sub> = -400 μA	2.4		V

- Note: 1. V<sub>CC</sub> must be applied simultaneously or before V<sub>PP</sub> and removed simultaneously or after V<sub>PP</sub>  
 2. V<sub>PP</sub> may be connected directly to V<sub>CC</sub>, except during programming. The supply current would then be the sum of I<sub>CC</sub> and I<sub>PP</sub>

## AC Characteristics for Read Operation

Symbol	Parameter	Condition	AT27C1024						Units						
			-45		-55		-70			-90		-12		-15	
			Min	Max	Min	Max	Min	Max		Min	Max	Min	Max	Min	Max
t <sub>ACC</sub> <sup>(3)</sup>	Address to Output Delay	$\overline{CE} = \overline{OE} = V_{IL}$	45		55		70		90		120		150	ns	
t <sub>CE</sub> <sup>(2)</sup>	$\overline{CE}$ to Output Delay	$\overline{OE} = V_{IL}$	45		55		70		90		120		150	ns	
t <sub>OE</sub> <sup>(2)(3)</sup>	$\overline{OE}$ to Output Delay	$\overline{CE} = V_{IL}$	20		25		25		30		35		50	ns	
t <sub>DF</sub> <sup>(4)(5)</sup>	$\overline{OE}$ or $\overline{CE}$ High to Output Float, whichever occurred first		20		25		25		30		30		40	ns	
t <sub>OH</sub>	Output Hold from Address, $\overline{CE}$ or $\overline{OE}$ , whichever occurred first		7		7		7		0		0		0	ns	

Notes: 2, 3, 4, 5. - see AC Waveforms for Read Operation.

## AC Waveforms for Read Operation<sup>(1)</sup>

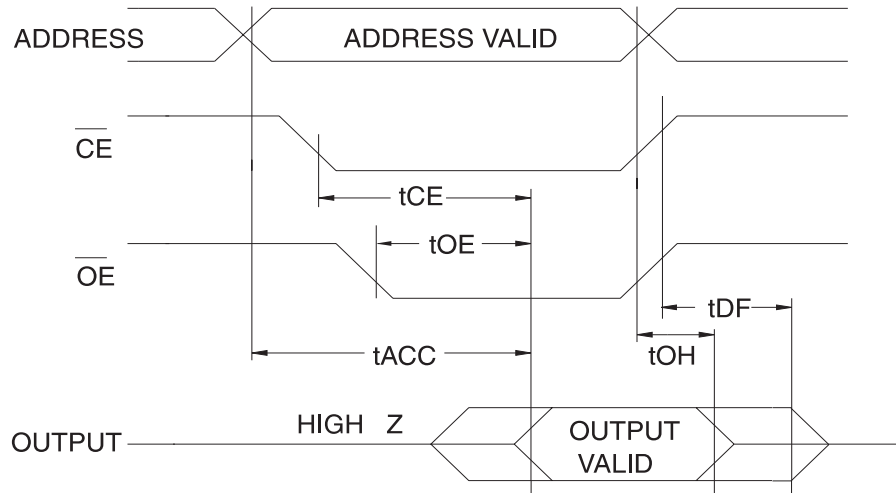

- Notes:
1. Timing measurement reference level is 1.5V for -45 and -55 devices. Input AC drive levels are  $V_{IL} = 0.0V$  and  $V_{IH} = 3.0V$ . Timing measurement reference levels for all other speed grades are  $V_{OL} = 0.8V$  and  $V_{OH} = 2.0V$ . Input AC drive levels are  $V_{IL} = 0.45V$  and  $V_{IH} = 2.4V$ .
  2.  $\overline{OE}$  may be delayed up to  $t_{CE} - t_{OE}$  after the falling edge of  $\overline{CE}$  without impact on  $t_{CE}$ .
  3.  $\overline{OE}$  may be delayed up to  $t_{ACC} - t_{OE}$  after the address is valid without impact on  $t_{ACC}$ .
  4. This parameter is only sampled and is not 100% tested.
  5. Output float is defined as the point when data is no longer driven.

## Pin Capacitance

( $f = 1 \text{ MHz}$   $T = 25^\circ\text{C}$ )<sup>(1)</sup>

	Typ	Max	Units	Conditions
$C_{IN}$	4	10	pF	$V_{IN} = 0V$
$C_{OUT}$	8	12	pF	$V_{OUT} = 0V$

Note: 1. Typical values for nominal supply voltage. This parameter is only sampled and is not 100% tested.

## Input Test Waveforms and Measurement Levels

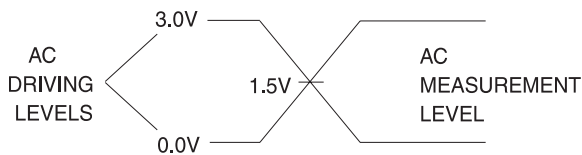

For -45 and -55 Devices Only

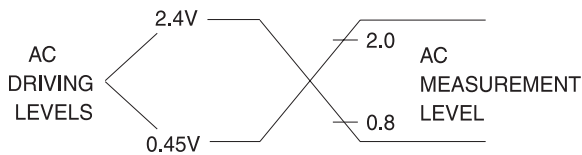

For -70 and slower Devices Only

## Output Test Load

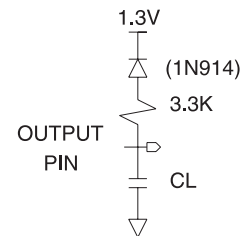

Note:  $C_L = 100 \text{ pF}$  including jig capacitance except -45 and -55 devices, where  $C_L = 30 \text{ pF}$ .

## Programming Waveforms<sup>(1)</sup>

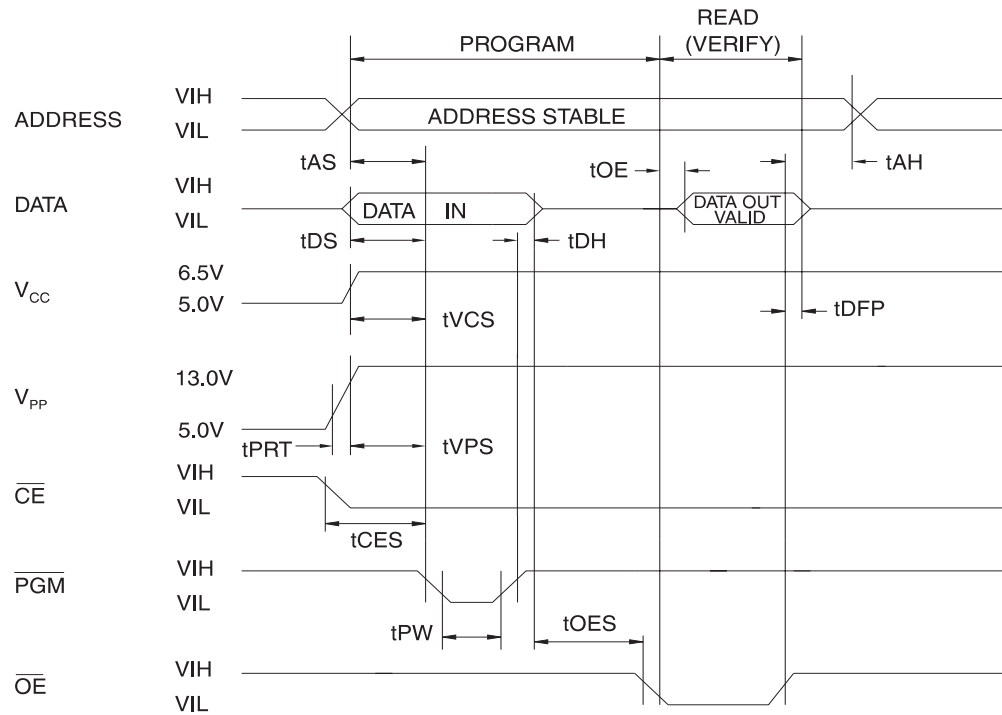

- Notes:
1. The Input Timing Reference is 0.8V for V<sub>IL</sub> and 2.0V for V<sub>IH</sub>.
  2. t<sub>OE</sub> and t<sub>DFP</sub> are characteristics of the device but must be accommodated by the programmer.
  3. When programming the AT27C1024 a 0.1 μF capacitor is required across V<sub>PP</sub> and ground to suppress spurious voltage transients.

## DC Programming Characteristics

TA = 25 ± 5°C, V<sub>CC</sub> = 6.5 ± 0.25V, V<sub>PP</sub> = 13.0 ± 0.25V

Symbol	Parameter	Test Conditions	Limits		Units
			Min	Max	
I <sub>LI</sub>	Input Load Current	V <sub>IN</sub> = V <sub>IL</sub> , V <sub>IH</sub>		±10	μA
V <sub>IL</sub>	Input Low Level		-0.6	0.8	V
V <sub>IH</sub>	Input High Level		2.0	V <sub>CC</sub> + 0.1	V
V <sub>OL</sub>	Output Low Voltage	I <sub>OL</sub> = 2.1 mA		0.4	V
V <sub>OH</sub>	Output High Voltage	I <sub>OH</sub> = -400 μA	2.4		V
I <sub>CC2</sub>	V <sub>CC</sub> Supply Current (Program and Verify)			50	mA
I <sub>PP2</sub>	V <sub>PP</sub> Supply Current	CE = PGM = V <sub>IL</sub>		30	mA
V <sub>ID</sub>	A9 Product Identification Voltage		11.5	12.5	V

## AC Programming Characteristics

$T_A = 25 \pm 5^\circ\text{C}$ ,  $V_{CC} = 6.5 \pm 0.25\text{V}$ ,  $V_{PP} = 13.0 \pm 0.25\text{V}$

Symbol	Parameter	Test Conditions <sup>(1)</sup>	Limits		Units	
			Min	Max		
$t_{AS}$	Address Setup Time	Input Rise and Fall Times (10% to 90%) 20ns	2		$\mu\text{s}$	
$t_{CES}$	$\overline{CE}$ Setup Time		2		$\mu\text{s}$	
$t_{OES}$	$\overline{OE}$ Setup Time		2		$\mu\text{s}$	
$t_{DS}$	Data Setup Time		2		$\mu\text{s}$	
$t_{AH}$	Address Hold Time		Input Pulse Levels 0.45V to 2.4V	0		$\mu\text{s}$
$t_{DH}$	Data Hold Time			2		$\mu\text{s}$
$t_{DFP}$	$\overline{OE}$ High to Output Float Delay <sup>(2)</sup>		Input Timing Reference Level 0.8V to 2.0V	0	130	ns
$t_{VPS}$	$V_{PP}$ Setup Time			2		$\mu\text{s}$
$t_{VCS}$	$V_{CC}$ Setup Time			Output Timing Reference Level 0.8V to 2.0V	2	
$t_{PW}$	$\overline{PGM}$ Program Pulse Width <sup>(3)</sup>		95		105	$\mu\text{s}$
$t_{OE}$	Data Valid from $\overline{OE}$		150		ns	
$t_{PRT}$	$V_{PP}$ Pulse Rise Time During Programming	50			ns	

- Notes:
- $V_{CC}$  must be applied simultaneously or before  $V_{PP}$  and removed simultaneously or after  $V_{PP}$
  - This parameter is only sampled and is not 100% tested. Output Float is defined as the point where data is no longer driven — see timing diagram.
  - Program Pulse width tolerance is  $100 \mu\text{sec} \pm 5\%$ .

## Atmel's 27C1024 Integrated Product Identification Code

Codes	Pins										Hex Data
	A0	015-08	07	06	05	04	03	02	01	00	
Manufacturer	0	0	0	0	0	1	1	1	1	0	001E
Device Type	1	0	1	1	1	1	0	0	0	1	00F1

## Rapid Programming Algorithm

A 100  $\mu\text{s}$  PGM pulse width is used to program. The address is set to the first location.  $V_{CC}$  is raised to 6.5V and  $V_{PP}$  is raised to 13.0V. Each address is first programmed with one 100  $\mu\text{s}$  PGM pulse without verification. Then a verification / reprogramming loop is executed for each address. In the event a word fails to pass verification, up to 10 successive 100  $\mu\text{s}$  pulses are applied with a verification

after each pulse. If the word fails to verify after 10 pulses have been applied, the part is considered failed. After the word verifies properly, the next address is selected until all have been checked.  $V_{PP}$  is then lowered to 5.0V and  $V_{CC}$  to 5.0V. All words are read again and compared with the original data to determine if the device passes or fails.

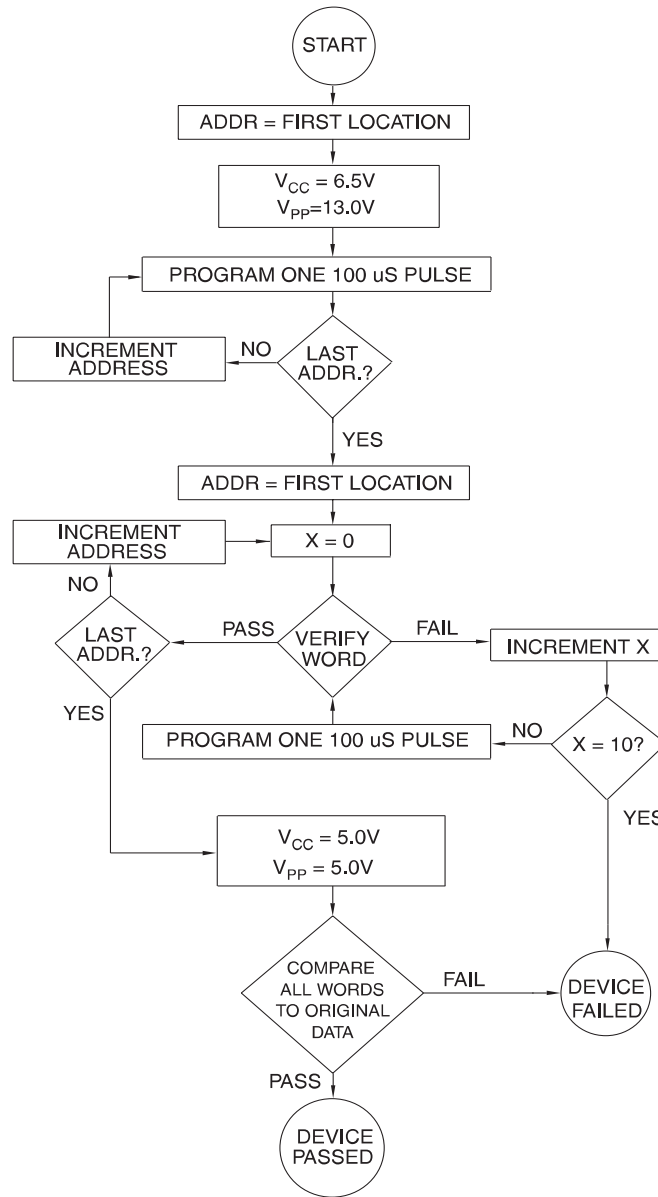



## Ordering Information

t <sub>ACC</sub> (ns)	I <sub>CC</sub> (mA)		Ordering Code	Package	Operation Range
	Active	Standby			
45	30	0.1	AT27C1024-45JC AT27C1024-45PC AT27C1024-45VC	44J 40P6 40V	Commercial (0°C to 70°C)
	30	0.1	AT27C1024-45JI AT27C1024-45PI AT27C1024-45VI	44J 40P6 40V	Industrial (-40°C to 85°C)
55	30	0.1	AT27C1024-55JC AT27C1024-55PC AT27C1024-55VC	44J 40P6 40V	Commercial (0°C to 70°C)
	30	0.1	AT27C1024-55JI AT27C1024-55PI AT27C1024-55VI	44J 40P6 40V	Industrial (-40°C to 85°C)
70	30	0.1	AT27C1024-70JC AT27C1024-70PC AT27C1024-70VC	44J 40P6 40V	Commercial (0°C to 70°C)
	30	0.1	AT27C1024-70JI AT27C1024-70PI AT27C1024-70VI	44J 40P6 40V	Industrial (-40°C to 85°C)
90	30	0.1	AT27C1024-90JC AT27C1024-90PC AT27C1024-90VC	44J 40P6 40V	Commercial (0°C to 70°C)
	30	0.1	AT27C1024-90JI AT27C1024-90PI AT27C1024-90VI	44J 40P6 40V	Industrial (-40°C to 85°C)
120	30	0.1	AT27C1024-12JC AT27C1024-12PC AT27C1024-12VC	44J 40P6 40V	Commercial (0°C to 70°C)
	30	0.1	AT27C1024-12JI AT27C1024-12PI AT27C1024-12VI	44J 40P6 40V	Industrial (-40°C to 85°C)
150	30	0.1	AT27C1024-15JC AT27C1024-15PC AT27C1024-15VC	44J 40P6 40V	Commercial (0°C to 70°C)
	30	0.1	AT27C1024-15JI AT27C1024-15PI AT27C1024-15VI	44J 40P6 40V	Industrial (-40°C to 85°C)

Package Type	
<b>44J</b>	44-Lead, Plastic J-Leaded Chip Carrier (PLCC)
<b>40P6</b>	40-Lead, 0.600" Wide, Plastic Dual Inline Package (PDIP)
<b>40V</b>	40-Lead, Plastic Thin Small Outline Package (TSOP) 10 x 14 mm

Copyright © Each Manufacturing Company.

All Datasheets cannot be modified without permission.

This datasheet has been download from :

[www.AllDataSheet.com](http://www.AllDataSheet.com)

100% Free DataSheet Search Site.

Free Download.

No Register.

Fast Search System.

[www.AllDataSheet.com](http://www.AllDataSheet.com)