

MAXIM

High-Speed, Low-Voltage, 4Ω, Dual SPST CMOS Analog Switches

General Description

The MAX4641/MAX4642/MAX4643 are monolithic, dual, single-pole/single-throw (SPST) switches that can operate from a single supply ranging from +1.8V to +5.5V. The MAX4641/MAX4642/MAX4643 provide low 4Ω on-resistance (RON), 0.6Ω RON matching between channels, and 1Ω RON flatness over the entire analog signal range. These devices offer fast switching times of less than 20ns while consuming less than 0.01μW of quiescent power.

The MAX4641 has two normally open (NO) switches, and the MAX4642 has two normally closed (NC) switches. The MAX4643 has one NO switch and one NC switch. All three devices have low 0.35nA leakage currents over the entire temperature range. The MAX4641/MAX4642/MAX4643 are available in small 8-pin μMAX and 8-pin QFN packages.

Applications

- Battery-Operated Equipment
- Audio and Video Signal Routing
- Low-Voltage Data-Acquisition Systems
- Sample-and-Hold Circuits
- Communications Circuits

Rail-to-Rail is a trademark of Nippon Motorola, Ltd.

Features

- ◆ +1.8V to +5.5V Single-Supply Operation
- ◆ Rail-to-Rail™ Analog Signal Range
- ◆ Guaranteed RON
 - 4Ω max (+5V supply)
 - 8Ω max (+3V supply)
- ◆ +1.8V Operation
 - RON 30Ω typ Over Temperature
 - ton 18ns typ, toff 12ns typ
- ◆ Guaranteed RON Flatness: 1Ω (+5V supply)
- ◆ Guaranteed RON Match Between Channels
 - 0.6Ω (+5V supply)
- ◆ Low Leakage (<0.35nA) Over Entire Temperature Range
- ◆ Excellent AC Characteristics
 - Low Crosstalk: -97dB at 1MHz
 - High Off-Isolation: -80dB at 1MHz
 - 0.018% Total Harmonic Distortion
- ◆ Low Power Consumption: < 0.01μW

Ordering Information

PART	TEMP RANGE	PIN-PACKAGE
MAX4641EUA	-40°C to +85°C	8 μMAX
MAX4641EGA	-40°C to +85°C	8 QFN 3 x 3
MAX4642EUA	-40°C to +85°C	8 μMAX
MAX4642EGA	-40°C to +85°C	8 QFN 3 x 3
MAX4643EUA	-40°C to +85°C	8 μMAX
MAX4643EGA	-40°C to +85°C	8 QFN 3 x 3

Pin Configurations/Functional Diagrams/Truth Tables

TOP VIEW

MAX4641

IN_	NO_
0	OFF
1	ON

MAX4642

IN_	NC_
0	ON
1	OFF

MAX4643

IN_	NO1	NC2
0	OFF	ON
1	ON	OFF

Pin Configurations continued at end of data sheet.

MAX4641/MAX4642/MAX4643

High-Speed, Low-Voltage, 4Ω, Dual SPST CMOS Analog Switches

ABSOLUTE MAXIMUM RATINGS

(All Voltages Referenced to GND)

V+	-0.3V to +6V
IN ₋ , COM ₋ , NO ₋ , NC ₋ (Note 1)	-0.3V to (V+ + 0.3V)
Continuous Current (any terminal)	±20mA
Continuous Current (NO ₋ , NC ₋ , COM ₋)	±50mA
Peak Current (NO ₋ , NC ₋ , COM ₋ , pulsed at 1ms, 10% duty cycle)	±100mA

Continuous Power Dissipation (T_A = +70°C)

8-Pin μMAX (derate 4.5mW/°C above +70°C)	362mW
8-Pin QFN (derate 24.4mW/°C above +70°C)	1951mW
Operating Temperature Range	-40°C to +85°C
Junction Temperature	+150°C
Storage Temperature Range	-65°C to +150°C
Lead Temperature (soldering, 10s)	+300°C

Note 1: Signals on NO₋, NC₋, COM₋, or IN₋ exceeding V+ or GND are clamped by internal diodes. Limit forward-diode current to maximum current rating.

Stresses beyond those listed under "Absolute Maximum Ratings" may cause permanent damage to the device. These are stress ratings only, and functional operation of the device at these or any other conditions beyond those indicated in the operational sections of the specifications is not implied. Exposure to absolute maximum rating conditions for extended periods may affect device reliability.

ELECTRICAL CHARACTERISTICS—Single +5V Supply

(V+ = +4.5V to +5.5V, V_{INH} = 2.4V, V_{INL} = 0.8V, T_A = T_{MIN} to T_{MAX}, unless otherwise noted. Typical values are at T_A = +25°C.)

PARAMETER	SYMBOL	CONDITIONS	MIN	TYP	MAX	UNITS	
ANALOG SWITCH							
Analog Signal Range	V _{COM-} , V _{NO-} , V _{NC-}		0		V+	V	
On-Resistance	R _{ON}	V+ = 4.5V, I _{COM-} = 10mA, V _{NO-} or V _{NC-} = 0 to V+	T _A = +25°C		2.5	4	Ω
			T _A = T _{MIN} to T _{MAX}		5		
On-Resistance Match Between Channels (Notes 2, 8)	ΔR _{ON}	V+ = 4.5V, I _{COM-} = 10mA, V _{NO-} or V _{NC-} = 0 to V+	T _A = +25°C		0.2	0.6	Ω
			T _A = T _{MIN} to T _{MAX}		0.8		
On-Resistance Flatness (Note 3)	R _{FLAT}	V+ = 4.5V, I _{COM-} = 10mA, V _{NO-} or V _{NC-} = 0 to V+	T _A = +25°C		0.85	1	Ω
			T _A = T _{MIN} to T _{MAX}		1.5		
NO ₋ , NC ₋ Off-Leakage Current (Note 4)	I _{NO-(OFF)} , I _{NC-(OFF)}	V+ = 5.5V, V _{COM-} = 1V or 4.5V, V _{NO-} or V _{NC-} = 4.5V or 1V	T _A = +25°C		-0.25	0.01	nA
			T _A = T _{MIN} to T _{MAX}		-0.35	0.35	
COM ₋ Off-Leakage Current (Note 4)	I _{COM-(OFF)}	V+ = 5.5V, V _{COM-} = 1V or 4.5V, V _{NO-} or V _{NC-} = 4.5V or 1V	T _A = +25°C		-0.25	0.01	nA
			T _A = T _{MIN} to T _{MAX}		-0.35	0.35	
COM ₋ On-Leakage Current (Notes 4, 5)	I _{COM-(ON)}	V+ = 5.5V, V _{COM-} = 1V or 4.5V	T _A = +25°C		-0.25	0.01	nA
			T _A = T _{MIN} to T _{MAX}		-0.35	0.35	
DIGITAL INPUTS							
IN ₋ Input Logic High	V _{IH}		2.4			V	
IN ₋ Input Logic Low	V _{IL}				0.8	V	
IN ₋ Input Current	I _{IN}	V _{IN-} = 0.8V or 2.4V	-0.1	0.005	0.1	μA	

High-Speed, Low-Voltage, 4Ω, Dual SPST CMOS Analog Switches

MAX4641/MAX4642/MAX4643

ELECTRICAL CHARACTERISTICS—Single +5V Supply (continued)

(V+ = +4.5V to +5.5V, VINH = 2.4V, VINL = 0.8V, TA = TMIN to TMAX, unless otherwise noted. Typical values are at TA = +25°C.)

PARAMETER	SYMBOL	CONDITIONS	MIN	TYP	MAX	UNITS
DYNAMIC						
Turn-On Time (Note 4)	tON	RL = 300Ω, CL = 35pF, VNO_ = VNC_ = 3V, Figure 2	TA = +25°C	9	15	ns
			TA = TMIN to TMAX		18	
Turn-Off Time (Note 4)	tOFF	RL = 300Ω, CL = 35pF, VNO_ = VNC_ = 3V, Figure 2	TA = +25°C	5	8	ns
			TA = TMIN to TMAX		10	
Break-Before-Make (Note 4) (MAX4643 only)	tBBM	RL = 300Ω, CL = 35pF, VNO_ = VNC_ = 3V, Figure 2	TA = +25°C	7		ns
			TA = TMIN to TMAX	1		
Charge Injection	Q	VGEN = 0, RGEN = 0, CL = 1nF, Figure 4		2		pC
NO_, NC_ Off-Capacitance	CNO_ (OFF), CNC_ (OFF)	NO_ or NC_ = GND, f = 1MHz, Figure 5		7		pF
COM_ Off-Capacitance	C _{COM_} (OFF)	f = 1MHz, Figure 5		7		pF
Switch On-Capacitance	C(ON)	f = 1MHz, Figure 5		18		pF
Off-Isolation (Note 6)	VISO	CL = 5pF, RL = 50Ω, Figure 3	f = 10MHz	-56		dB
			f = 1MHz	-80		
Crosstalk (Note 7)	VCT	CL = 5pF, RL = 50Ω, Figure 3	f = 10MHz	-77		dB
			f = 1MHz	-97		
Total Harmonic Distortion	THD	RL = 600Ω, 0.5Vp-p, f = 20Hz to 20kHz		0.018		%
SUPPLY						
Positive Supply Current	I+	V+ = 5.5V, VIN_ = 0 or V+		0.001	1.0	μA

ELECTRICAL CHARACTERISTICS—Single +3V Supply

(V+ = +2.7V to +3.3V, VINH = 2.0V, VINL = 0.4V, TA = TMIN to TMAX, unless otherwise noted. Typical values are at TA = +25°C.)

PARAMETER	SYMBOL	CONDITIONS	MIN	TYP	MAX	UNITS
ANALOG SWITCH						
Analog Signal Range	VCOM_, VNO_, VNC_		0		V+	V
On-Resistance	RON	V+ = 2.7V, ICOM_ = 10mA, VNO_ or VNC_ = 0 to V+	TA = +25°C	6	8	Ω
			TA = TMIN to TMAX		9	
On-Resistance Match Between Channels (Notes 2, 8)	ΔRON	V+ = 2.7V, ICOM_ = 10mA, VNO_ or VNC_ = 0 to V+	TA = +25°C	0.2	0.6	Ω
			TA = TMIN to TMAX		0.8	
On-Resistance Flatness (Note 3)	RFLAT	V+ = 2.7V, ICOM_ = 10mA, VNO_ or VNC_ = 0 to V+	TA = +25°C	1.5	3.0	Ω
			TA = TMIN to TMAX		3.5	

High-Speed, Low-Voltage, 4Ω, Dual SPST CMOS Analog Switches

ELECTRICAL CHARACTERISTICS—Single +3V Supply (continued)

(V+ = +2.7V to +3.3V, V_{INH} = 2.0V, V_{INL} = 0.4V, T_A = T_{MIN} to T_{MAX}, unless otherwise noted. Typical values are at T_A = +25°C.)

PARAMETER	SYMBOL	CONDITIONS	MIN	TYP	MAX	UNITS
DIGITAL INPUTS						
IN_ Input Logic High	V _{IH}		2.0			V
IN_ Input Logic Low	V _{IL}				0.4	V
IN_ Input Current	I _{IN}	V _{IN_} = 0.4V or 2.0V	-0.1	0.005	0.1	μA
DYNAMIC						
Turn-On Time (Note 4)	t _{ON}	R _L = 300Ω, C _L = 35pF, V _{NO_} = V _{NC_} = 2V, Figure 2	T _A = +25°C	14	20	ns
			T _A = T _{MIN} to T _{MAX}		22	
Turn-Off Time (Note 4)	t _{OFF}	R _L = 300Ω, C _L = 35pF, V _{NO_} = V _{NC_} = 2V, Figure 2	T _A = +25°C	6	10	ns
			T _A = T _{MIN} to T _{MAX}		11	
Break-Before-Make (Note 4) (MAX4643 only)	t _{BBM}	R _L = 300Ω, C _L = 35pF, V _{NO_} = V _{NC_} = 2V, Figure 2	T _A = +25°C	7		ns
			T _A = T _{MIN} to T _{MAX}	1		
Charge Injection	Q	V _{GEN} = 0, R _{GEN} = 0, C _L = 1nF, Figure 4		2		pC
NO_, NC_ Off-Capacitance	C _{NO_(OFF)} , C _{NC_(OFF)}	NO_ or NC_ = GND, f = 1MHz, Figure 5		7		pF
COM_ Off-Capacitance	C _{COM_(OFF)}	f = 1MHz, Figure 5		7		pF
Switch On-Capacitance	C _(ON)	f = 1MHz, Figure 5		18		pF
Off-Isolation (Note 6)	V _{ISO}	C _L = 5pF, R _L = 50Ω, Figure 3	f = 10MHz	-56		dB
			f = 1MHz	-80		
Crosstalk (Note 7)	V _{CT}	C _L = 5pF, R _L = 50Ω, Figure 3	f = 10MHz	-77		dB
			f = 1MHz	-97		
SUPPLY						
Positive Supply Current	I ₊	V ₊ = 3.3V, V _{IN_} = 0 or V ₊		0.001	1.0	μA

Note 2: $\Delta R_{ON} = R_{ON(MAX)} - R_{ON(MIN)}$.

Note 3: R_{ON} Flatness is defined as the difference between the maximum and minimum value of on-resistance as measured over the specified analog signal range.

Note 4: Guaranteed by design.

Note 5: On-Leakage performed with voltage applied to COM_, with NO_ and NC_ left floating.

Note 6: Off-Isolation = $20\log_{10}(V_{O_}/V_{I_})$, where V_{O_} is V_{COM_} and V_{I_} is V_{NC_} or V_{NO_} from the network analyzer.

Note 7: Crosstalk is measured between the two switches.

Note 8: R_{ON} and ΔR_{ON} matching specifications for QFN-packaged parts are guaranteed by design.

High-Speed, Low-Voltage, 4Ω, Dual SPST CMOS Analog Switches

Typical Operating Characteristics

(V+ = +5V or +3V, VINH = V+, VINL = GND, TA = +25°C, unless otherwise noted.)

MAX4641/MAX4642/MAX4643

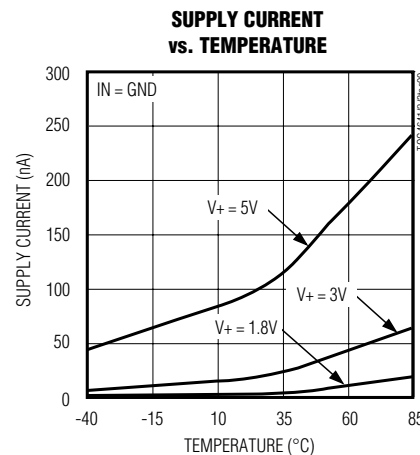
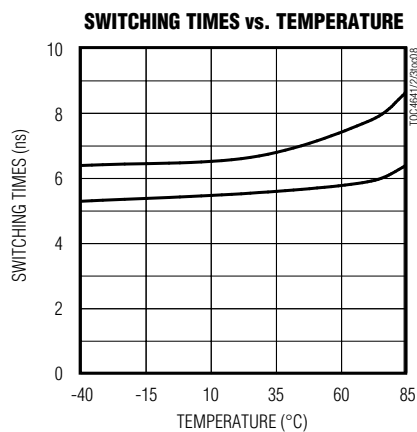
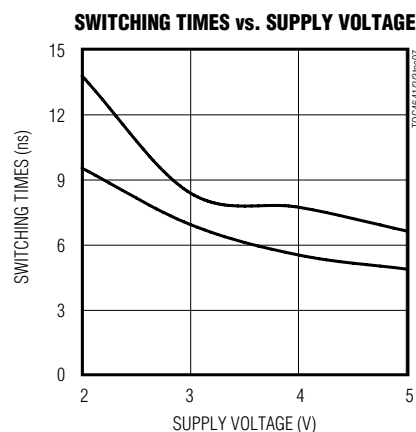
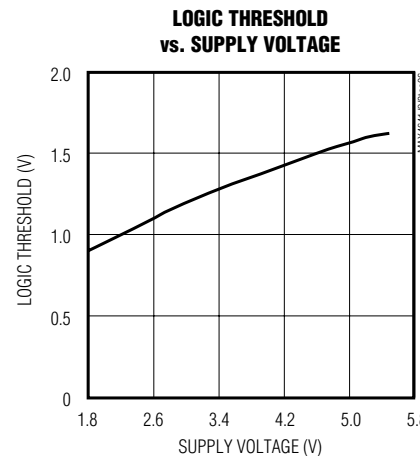
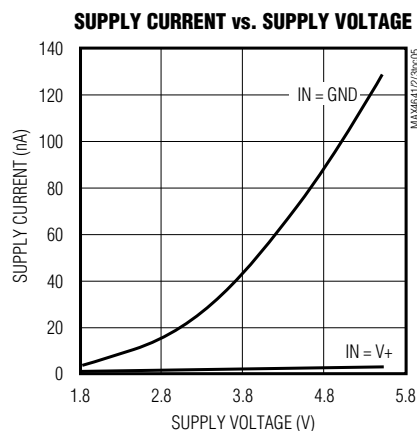
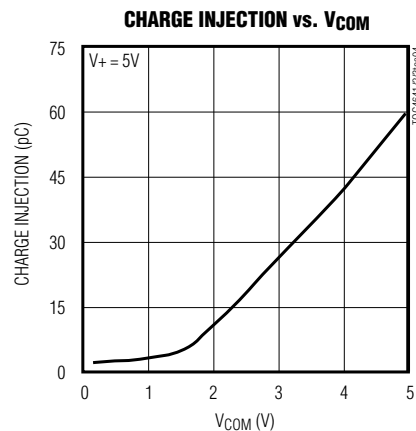
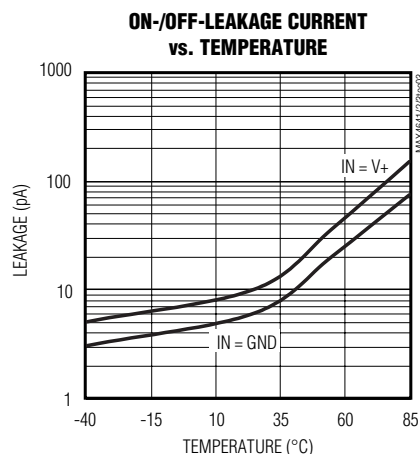
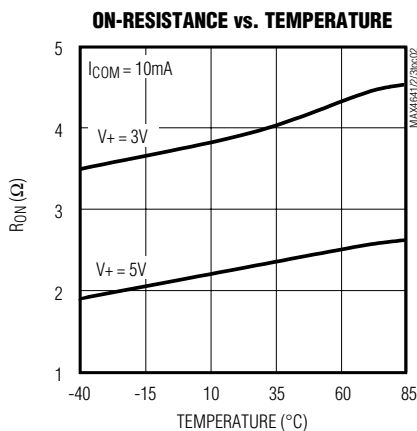
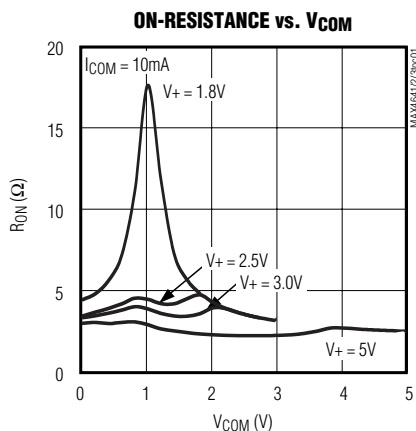

High-Speed, Low-Voltage, 4Ω, Dual SPST CMOS Analog Switches

Typical Operating Characteristics (continued)

(V+ = +5V or +3V, VINH = V+, VINL = GND, TA = +25°C, unless otherwise noted.)

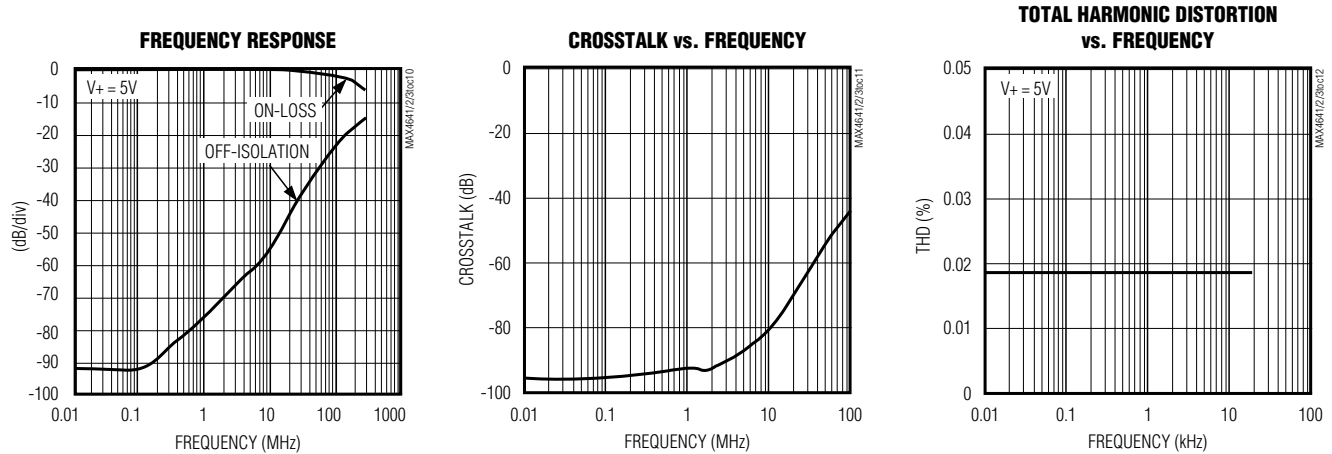

Pin Description

PIN			NAME	FUNCTION
MAX4641	MAX4642	MAX4643		
1, 5	–	–	NO1, NO2	Analog Switch Normally Open Terminals
–	1, 5	–	NC1, NC2	Analog Switch Normally Closed Terminals
–	–	1	NO1	Analog Switch Normally Open Terminal
–	–	5	NC2	Analog Switch Normally Closed Terminal
2, 6	2, 6	2, 6	COM1, COM2	Analog Switch Common Terminals
3, 7	3, 7	3, 7	IN2, IN1	Logic-Controlled Inputs
4	4	4	GND	Ground
8	8	8	V+	Positive Supply Input. Bypass with a 0.1μF capacitor to GND.

Note: NO_, NC_, and COM_ pins are identical and interchangeable. Signals can be passed through either side of these bidirectional switches. However, the typical off-capacitances differ, as shown in the *Electrical Characteristics*.

High-Speed, Low-Voltage, 4Ω, Dual SPST CMOS Analog Switches

Pin Configurations/Functional Diagrams/Truth Tables (continued)

MAX4641/MAX4642/MAX4643

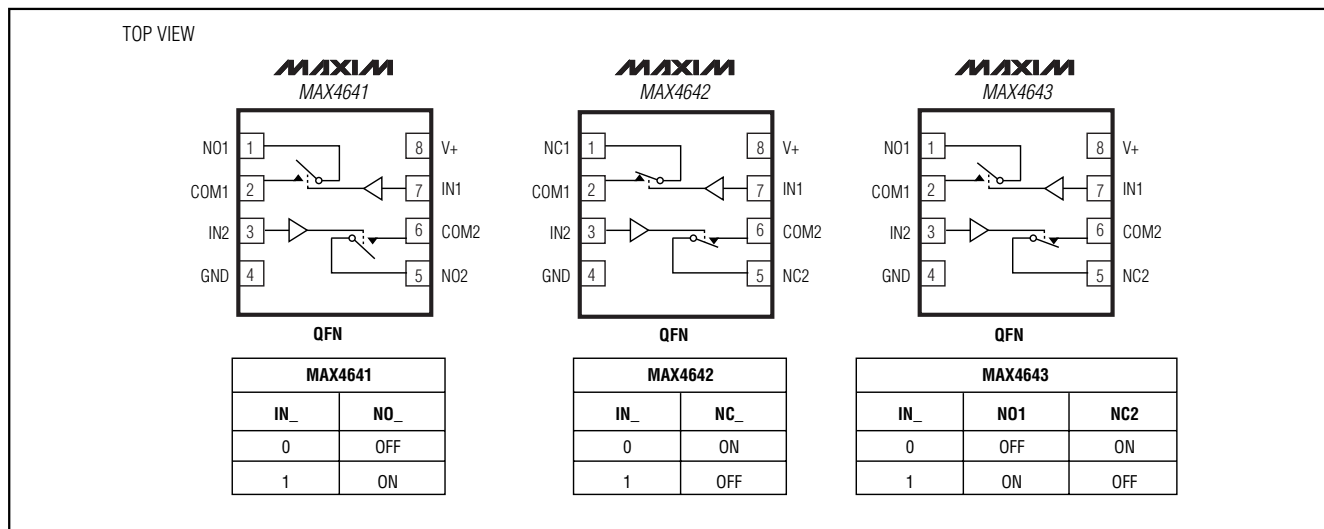

Applications Information

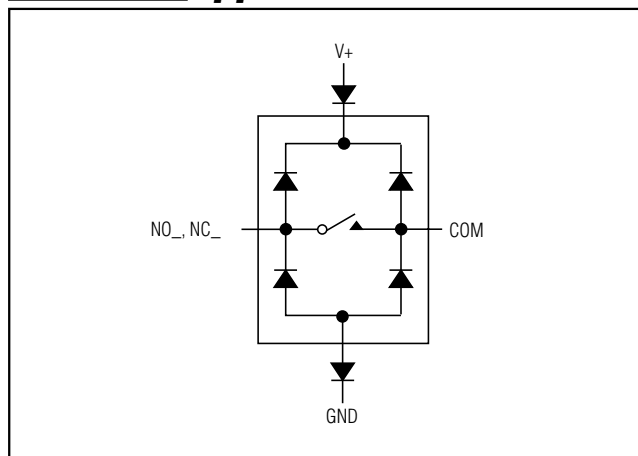

Figure 1. Overvoltage Protection Using External Blocking Diodes

exceeds $V+$ or GND (Figure 1). Virtually all of the analog leakage current comes from the ESD diodes to $V+$ or GND. Although the ESD diodes on a given signal pin are identical, and therefore fairly well balanced, they are reverse biased differently. Each is biased by either $V+$ or GND and the analog signal. This means their leakages will vary as the signal varies. The difference in the two diode leakages to the $V+$ and GND pins constitutes the analog-signal-path leakage current. All analog leakage current flows between each pin and one of the supply terminals, not to the other switch terminal. This is why both sides of a given switch can show leakage currents of the same or opposite polarity.

There is no normal current path between the analog-signal paths and $V+$ or GND. $V+$ and GND also power the internal logic and logic-level translators. The logic-level translators convert the logic level into switched $V+$ and GND signals to drive the analog signal gates.

The MAX4641/MAX4642/MAX4643 operate from a single supply ranging from +1.8V to +5.5V. The devices are guaranteed to be functional over that supply range, but TTL/CMOS compatibility is only valid for operation using a +5V supply. All voltage levels are referenced to GND. Positive and negative DC analog inputs or AC signals can be accommodated by shifting $V+$ and GND.

ESD-protection diodes are internally connected between each analog-signal pin and both $V+$ and GND. One of these diodes conducts if any analog signal

High-Speed, Low-Voltage, 4Ω, Dual SPST CMOS Analog Switches

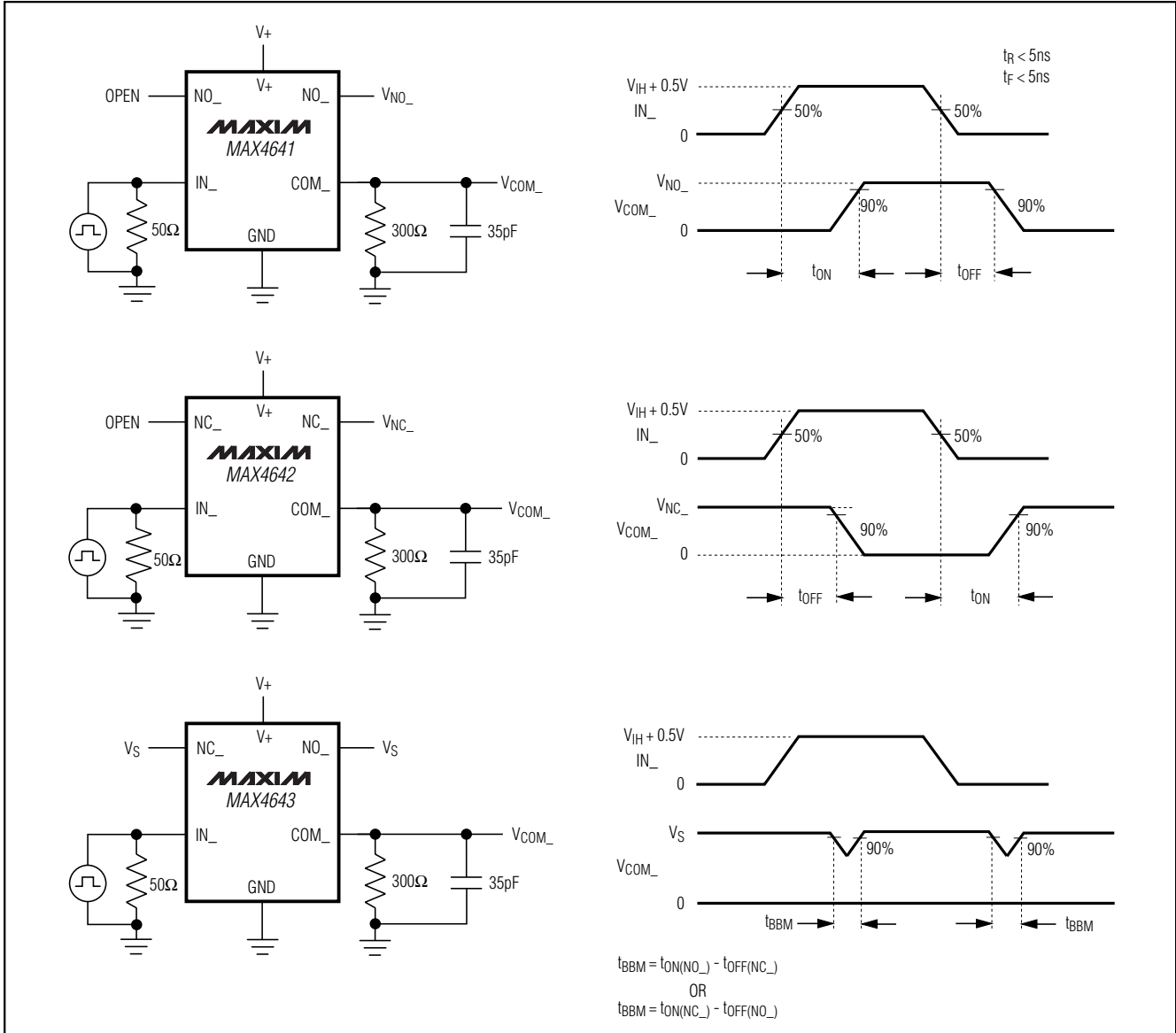

Figure 2. Switching Times

High-Speed, Low-Voltage, 4Ω, Dual SPST CMOS Analog Switches

MAX4641/MAX4642/MAX4643

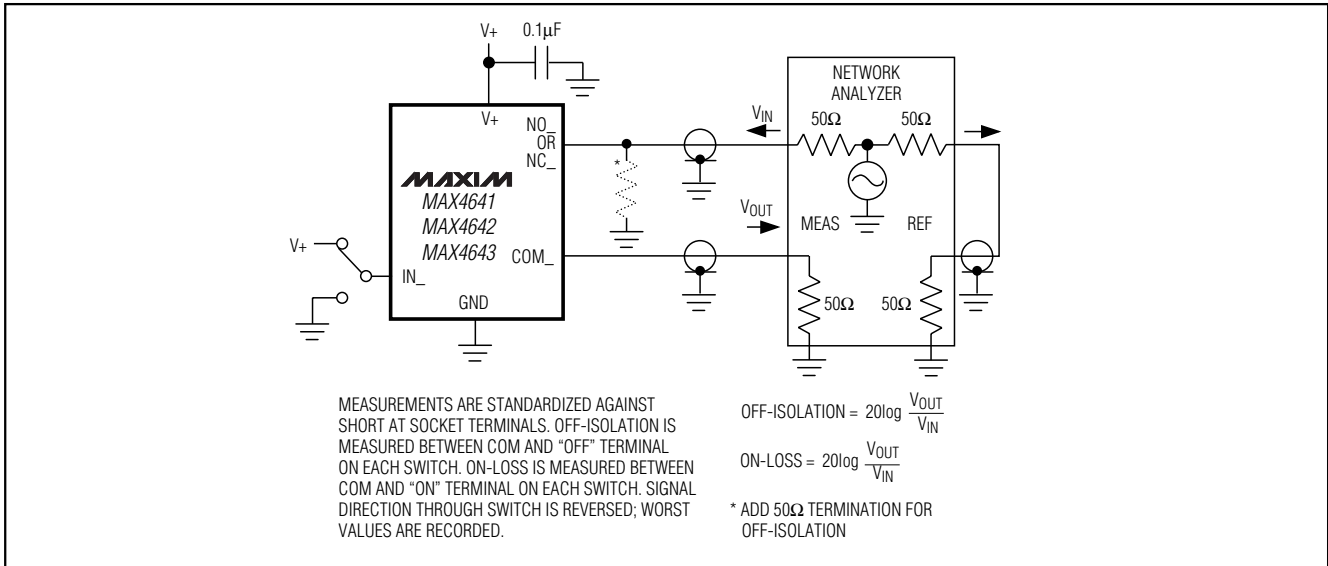

Figure 3. Off-Isolation, On-Loss, and Crosstalk

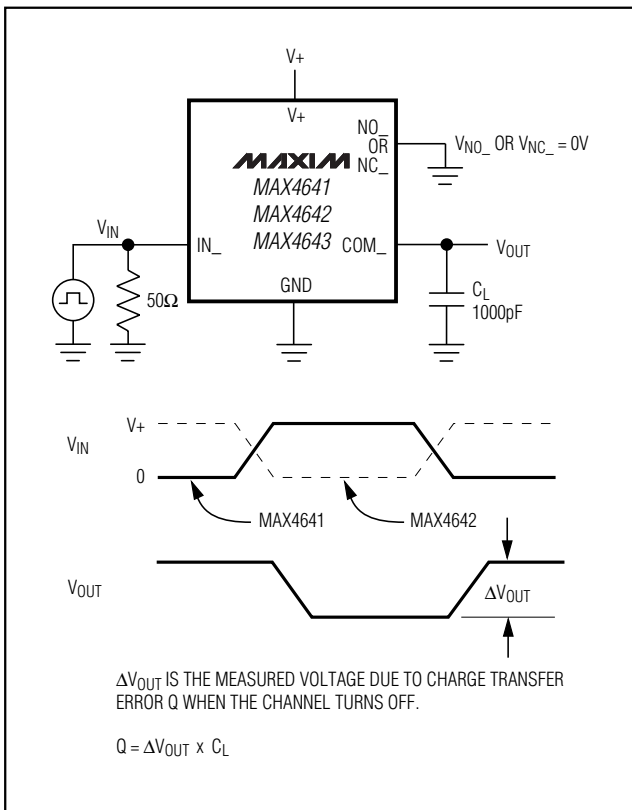

Figure 4. Charge Injection

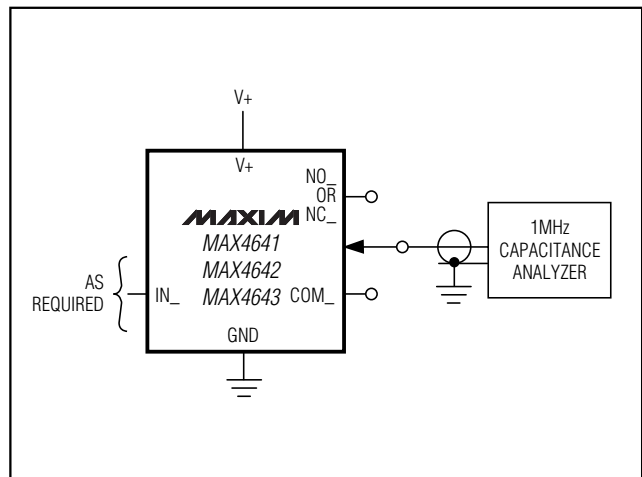

Figure 5. NO₁, NC₁, and COM₁ Capacitance

Chip Information

TRANSISTOR COUNT: 105

High-Speed, Low-Voltage, 4Ω, Dual SPST CMOS Analog Switches

Package Information

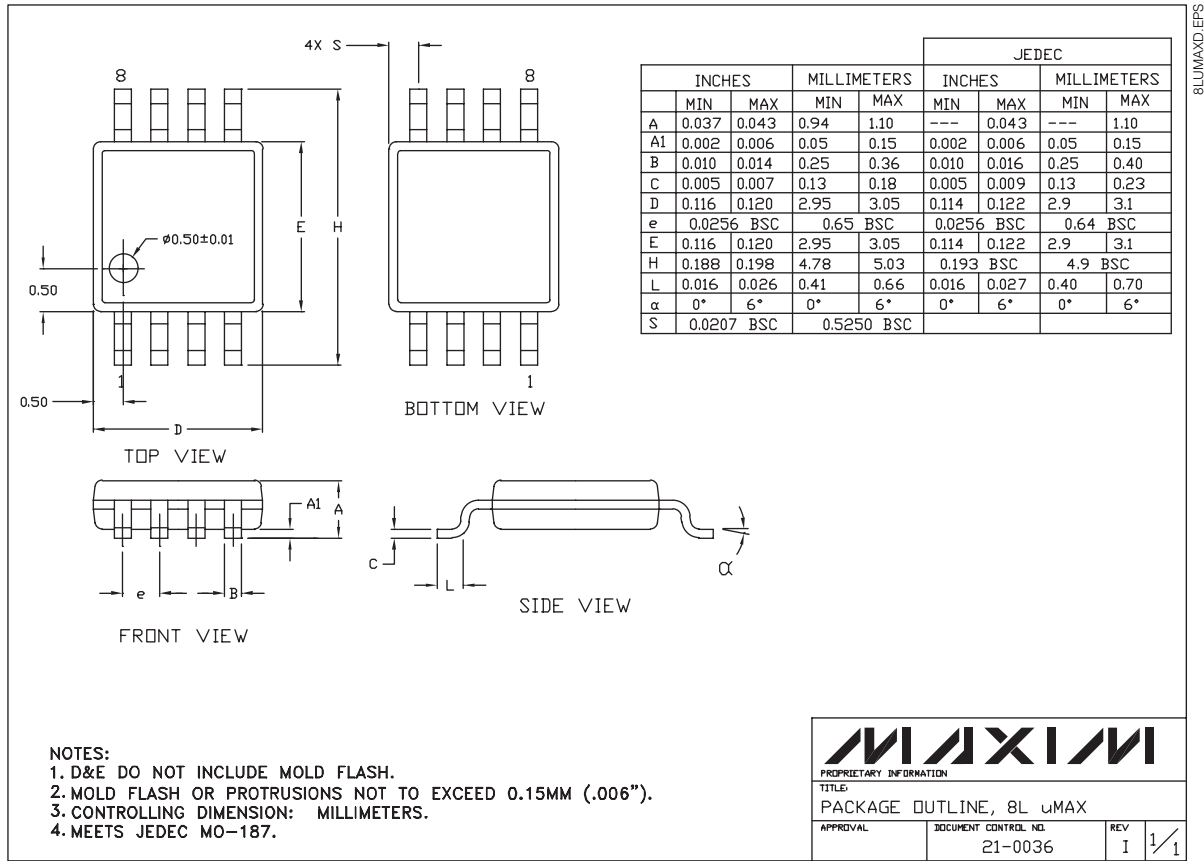

8LUMAXD.EPS

PROPRIETARY INFORMATION

TITLE:
PACKAGE OUTLINE, 8L uMAX

APPROVAL	DOCUMENT CONTROL NO. 21-0036	REV I	1/1
----------	---------------------------------	----------	-----

Maxim cannot assume responsibility for use of any circuitry other than circuitry entirely embodied in a Maxim product. No circuit patent licenses are implied. Maxim reserves the right to change the circuitry and specifications without notice at any time.

10 **Maxim Integrated Products, 120 San Gabriel Drive, Sunnyvale, CA 94086 408-737-7600**