

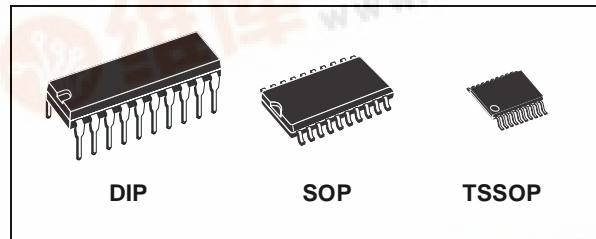

# M74HC541

## OCTAL BUS BUFFER WITH 3 STATE OUTPUTS (NON INVERTED)

- HIGH SPEED:  
 $t_{PD} = 9ns$  (TYP.) at  $V_{CC} = 6V$
- LOW POWER DISSIPATION:  
 $I_{CC} = 4\mu A$  (MAX.) at  $T_A = 25^\circ C$
- HIGH NOISE IMMUNITY:  
 $V_{NIH} = V_{NIL} = 28\% V_{CC}$  (MIN.)
- SYMMETRICAL OUTPUT IMPEDANCE:  
 $|I_{OH}| = |I_{OL}| = 6mA$  (MIN)
- BALANCED PROPAGATION DELAYS:  
 $t_{PLH} \cong t_{PHL}$
- WIDE OPERATING VOLTAGE RANGE:  
 $V_{CC}$  (OPR) = 2V to 6V
- PIN AND FUNCTION COMPATIBLE WITH  
 74 SERIES 541



### ORDER CODES

PACKAGE	TUBE	T & R
DIP	M74HC541B1R	
SOP	M74HC541M1R	M74HC541RM13TR
TSSOP		M74HC541TTR

### DESCRIPTION

The 74HC541 is an advanced high-speed CMOS OCTAL BUS BUFFER (3-STATE) fabricated with silicon gate C<sup>2</sup>MOS technology. The M74HC541 is a non inverting buffer.

The 3-STATE control gate operates as a two input AND such that if either  $\overline{G1}$  and  $\overline{G2}$  are high, all eight output are in the high impedance state. In

order to enhance PC board layout the M74HC541 offer a pinout having inputs and outputs on opposite sides of the package.

All inputs are equipped with protection circuits against static discharge and transient excess voltage.

### PIN CONNECTION AND IEC LOGIC SYMBOLS

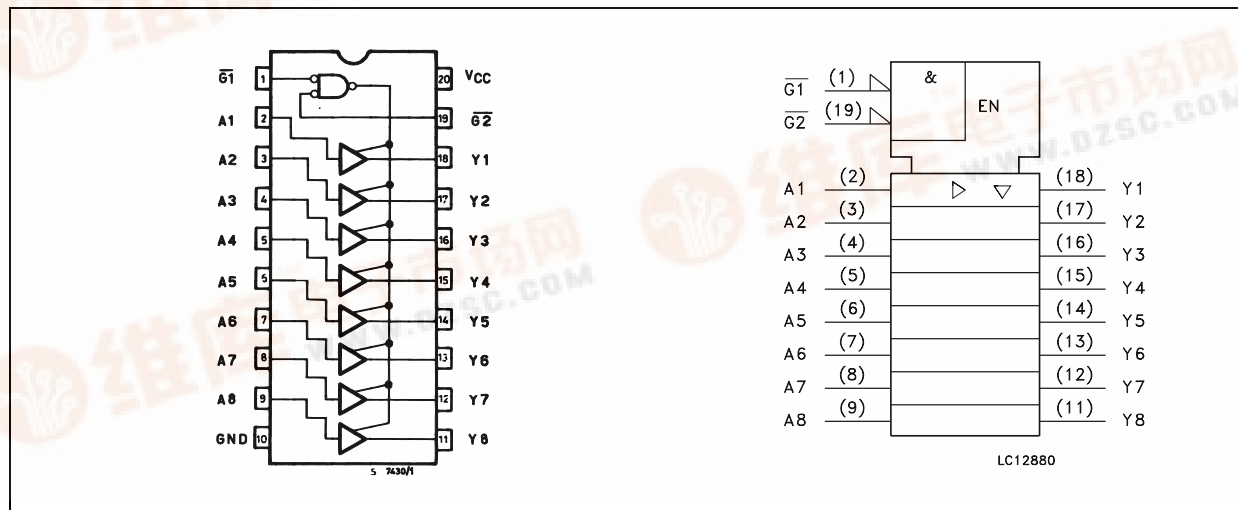

## M74HC541

### INPUT AND OUTPUT EQUIVALENT CIRCUIT

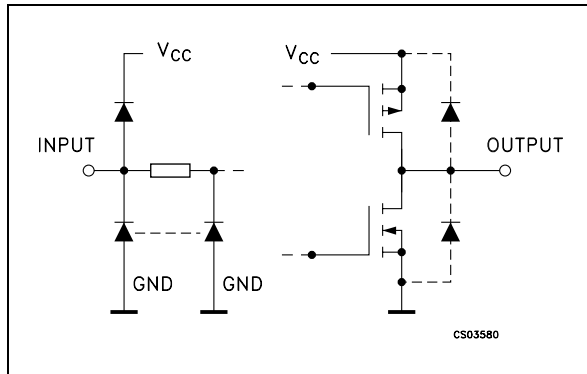

### PIN DESCRIPTION

PIN No	SYMBOL	NAME AND FUNCTION
1, 19	G1, G2	Output Enable Inputs
2, 3, 4, 5, 6, 7, 8, 9	A1 to A8	Data Inputs
18, 17, 16, 15, 14, 13, 12, 11	Y1 to Y8	Bus Outputs
10	GND	Ground (0V)
20	V <sub>CC</sub>	Positive Supply Voltage

### TRUTH TABLE

INPUT			OUTPUT
$\overline{G1}$	$\overline{G2}$	A <sub>n</sub>	Y <sub>n</sub>
H	X	X	Z
X	H	X	Z
L	L	H	H
L	L	L	L

X : Don't Care  
Z : High Impedance

### ABSOLUTE MAXIMUM RATINGS

Symbol	Parameter	Value	Unit
V <sub>CC</sub>	Supply Voltage	-0.5 to +7	V
V <sub>I</sub>	DC Input Voltage	-0.5 to V <sub>CC</sub> + 0.5	V
V <sub>O</sub>	DC Output Voltage	-0.5 to V <sub>CC</sub> + 0.5	V
I <sub>IK</sub>	DC Input Diode Current	± 20	mA
I <sub>OK</sub>	DC Output Diode Current	± 20	mA
I <sub>O</sub>	DC Output Current	± 35	mA
I <sub>CC</sub> or I <sub>GND</sub>	DC V <sub>CC</sub> or Ground Current	± 70	mA
P <sub>D</sub>	Power Dissipation	500(*)	mW
T <sub>stg</sub>	Storage Temperature	-65 to +150	°C
T <sub>L</sub>	Lead Temperature (10 sec)	300	°C

Absolute Maximum Ratings are those values beyond which damage to the device may occur. Functional operation under these conditions is not implied

(\*) 500mW at 65 °C; derate to 300mW by 10mW/°C from 65°C to 85°C

## RECOMMENDED OPERATING CONDITIONS

Symbol	Parameter	Value	Unit	
$V_{CC}$	Supply Voltage	2 to 6	V	
$V_I$	Input Voltage	0 to $V_{CC}$	V	
$V_O$	Output Voltage	0 to $V_{CC}$	V	
$T_{op}$	Operating Temperature	-55 to 125	°C	
$t_r, t_f$	Input Rise and Fall Time	$V_{CC} = 2.0V$	0 to 1000	ns
		$V_{CC} = 4.5V$	0 to 500	ns
		$V_{CC} = 6.0V$	0 to 400	ns

## DC SPECIFICATIONS

Symbol	Parameter	Test Condition		Value						Unit	
		$V_{CC}$ (V)		$T_A = 25^\circ\text{C}$			-40 to 85°C		-55 to 125°C		
				Min.	Typ.	Max.	Min.	Max.	Min.		Max.
$V_{IH}$	High Level Input Voltage	2.0		1.5			1.5		1.5		V
		4.5		3.15			3.15		3.15		
		6.0		4.2			4.2		4.2		
$V_{IL}$	Low Level Input Voltage	2.0				0.5		0.5		0.5	V
		4.5				1.35		1.35		1.35	
		6.0				1.8		1.8		1.8	
$V_{OH}$	High Level Output Voltage	2.0	$I_O = -20 \mu\text{A}$	1.9	2.0		1.9		1.9		V
		4.5	$I_O = -20 \mu\text{A}$	4.4	4.5		4.4		4.4		
		6.0	$I_O = -20 \mu\text{A}$	5.9	6.0		5.9		5.9		
		4.5	$I_O = -6.0 \text{ mA}$	4.18	4.31		4.13		4.10		
		6.0	$I_O = -7.8 \text{ mA}$	5.68	5.8		5.63		5.60		
$V_{OL}$	Low Level Output Voltage	2.0	$I_O = 20 \mu\text{A}$		0.0	0.1		0.1		0.1	V
		4.5	$I_O = 20 \mu\text{A}$		0.0	0.1		0.1		0.1	
		6.0	$I_O = 20 \mu\text{A}$		0.0	0.1		0.1		0.1	
		4.5	$I_O = 6.0 \text{ mA}$		0.17	0.26		0.33		0.40	
		6.0	$I_O = 7.8 \text{ mA}$		0.18	0.26		0.33		0.40	
$I_I$	Input Leakage Current	6.0	$V_I = V_{CC}$ or GND			$\pm 0.1$		$\pm 1$		$\pm 1$	$\mu\text{A}$
$I_{OZ}$	High Impedance Output Leakage Current	6.0	$V_I = V_{IH}$ or $V_{IL}$ $V_O = V_{CC}$ or GND			$\pm 0.5$		$\pm 5$		$\pm 10$	$\mu\text{A}$
$I_{CC}$	Quiescent Supply Current	6.0	$V_I = V_{CC}$ or GND			4		40		80	$\mu\text{A}$

## M74HC541

### AC ELECTRICAL CHARACTERISTICS ( $C_L = 50 \text{ pF}$ , Input $t_r = t_f = 6 \text{ ns}$ )

Symbol	Parameter	Test Condition			Value						Unit	
		$V_{CC}$ (V)	$C_L$ (pF)		$T_A = 25^\circ\text{C}$			$-40 \text{ to } 85^\circ\text{C}$		$-55 \text{ to } 125^\circ\text{C}$		
					Min.	Typ.	Max.	Min.	Max.	Min.		Max.
$t_{TLH}$ $t_{THL}$	Output Transition Time	2.0	50			25	60		75		90	ns
		4.5				7	12		19		18	
		6.0				6	10		13		15	
$t_{PLH}$ $t_{PHL}$	Propagation Delay Time	2.0	50			40	85		105		130	ns
		4.5				10	17		21		26	
		6.0				9	14		18		22	
		2.0	150			56	115		145		175	ns
		4.5				14	23		29		35	
		6.0				12	20		25		30	
$t_{PZL}$ $t_{PZH}$	High Impedance Output Enable Time	2.0	50	$R_L = 1 \text{ K}\Omega$		47	110		140		165	ns
		4.5				13	22		28		33	
		6.0				11	19		24		28	
		2.0	150	$R_L = 1 \text{ K}\Omega$		61	135		170		205	ns
		4.5				17	27		34		41	
		6.0				14	23		29		35	
$t_{PLZ}$ $t_{PHZ}$	High Impedance Output Disable Time	2.0	50	$R_L = 1 \text{ K}\Omega$		52	110		140		165	ns
		4.5				15	22		28		33	
		6.0				13	19		24		28	

### CAPACITIVE CHARACTERISTICS

Symbol	Parameter	Test Condition			Value						Unit	
		$V_{CC}$ (V)			$T_A = 25^\circ\text{C}$			$-40 \text{ to } 85^\circ\text{C}$		$-55 \text{ to } 125^\circ\text{C}$		
					Min.	Typ.	Max.	Min.	Max.	Min.		Max.
$C_{IN}$	Input Capacitance	5.0				5	10		10		10	pF
$C_{PD}$	Power Dissipation Capacitance (note 1)	5.0				31						pF

1)  $C_{PD}$  is defined as the value of the IC's internal equivalent capacitance which is calculated from the operating current consumption without load. (Refer to Test Circuit). Average operating current can be obtained by the following equation.  $I_{CC(oper)} = C_{PD} \times V_{CC} \times f_{IN} + I_{CC}/8$  (per circuit)

TEST CIRCUIT

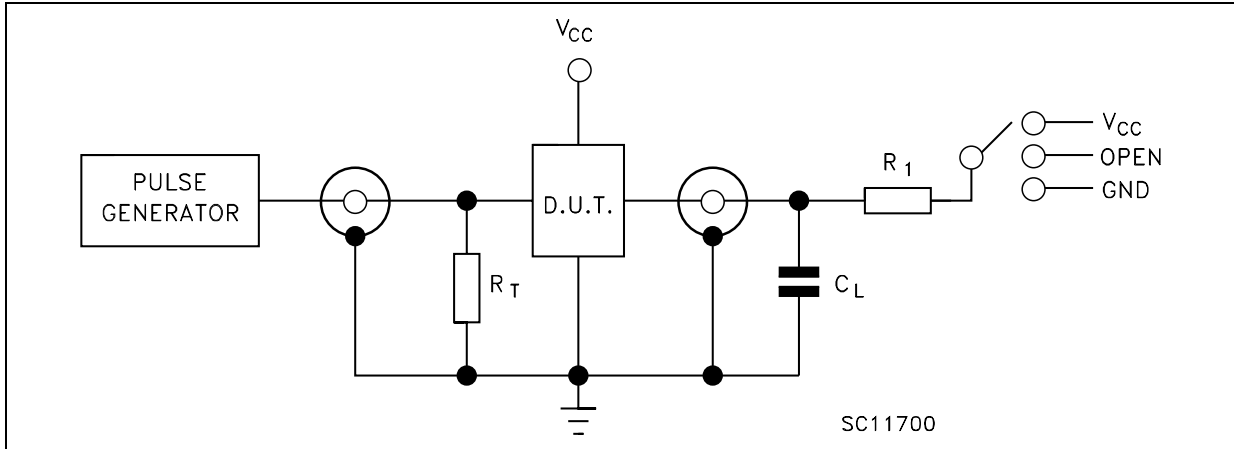

TEST	SWITCH
$t_{PLH}$ , $t_{PHL}$	Open
$t_{PZL}$ , $t_{PLZ}$	$V_{CC}$
$t_{PZH}$ , $t_{PHZ}$	GND

$C_L$  = 50pF/150pF or equivalent (includes jig and probe capacitance)  
 $R_1$  = 1K $\Omega$  or equivalent  
 $R_T$  =  $Z_{OUT}$  of pulse generator (typically 50 $\Omega$ )

WAVEFORM 1: PROPAGATION DELAY TIMES (f=1MHz; 50% duty cycle)

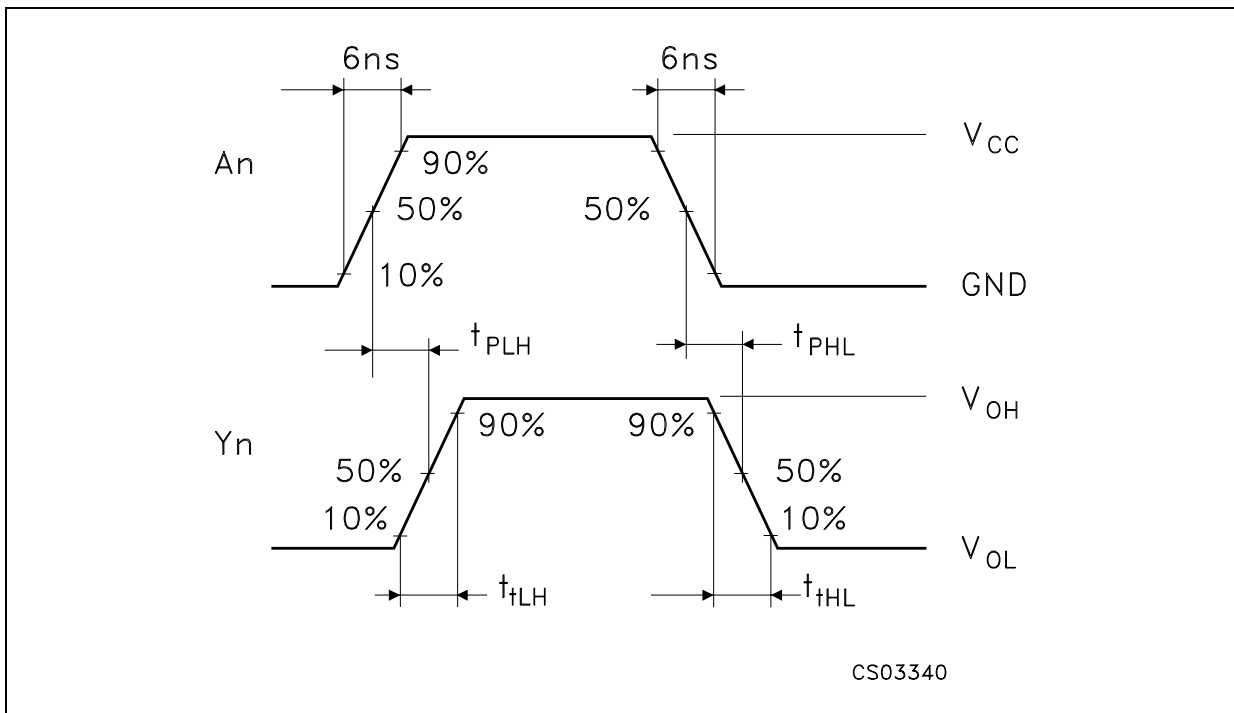

M74HC541

WAVEFORM 2 : OUTPUT ENABLE AND DISABLE TIMES (f=1MHz; 50% duty cycle)

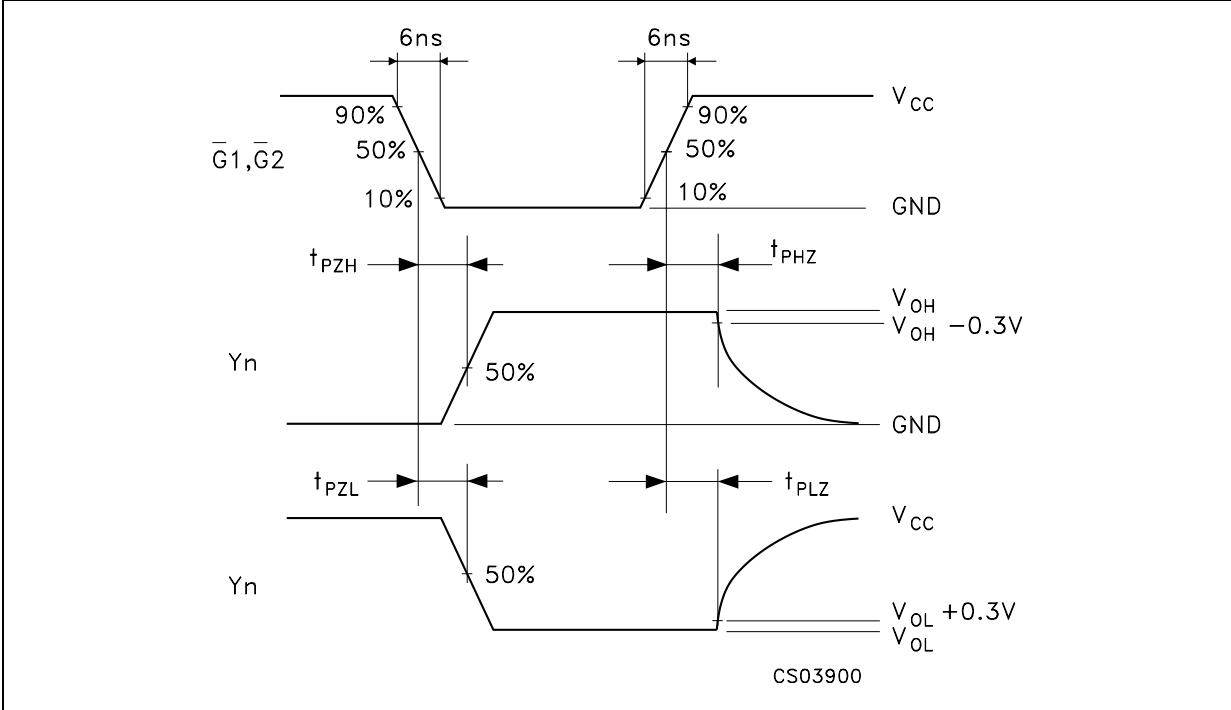

### Plastic DIP-20 (0.25) MECHANICAL DATA

DIM.	mm.			inch		
	MIN.	TYP.	MAX.	MIN.	TYP.	MAX.
a1	0.254			0.010		
B	1.39		1.65	0.055		0.065
b		0.45			0.018	
b1		0.25			0.010	
D			25.4			1.000
E		8.5			0.335	
e		2.54			0.100	
e3		22.86			0.900	
F			7.1			0.280
l			3.93			0.155
L		3.3			0.130	
Z			1.34			0.053

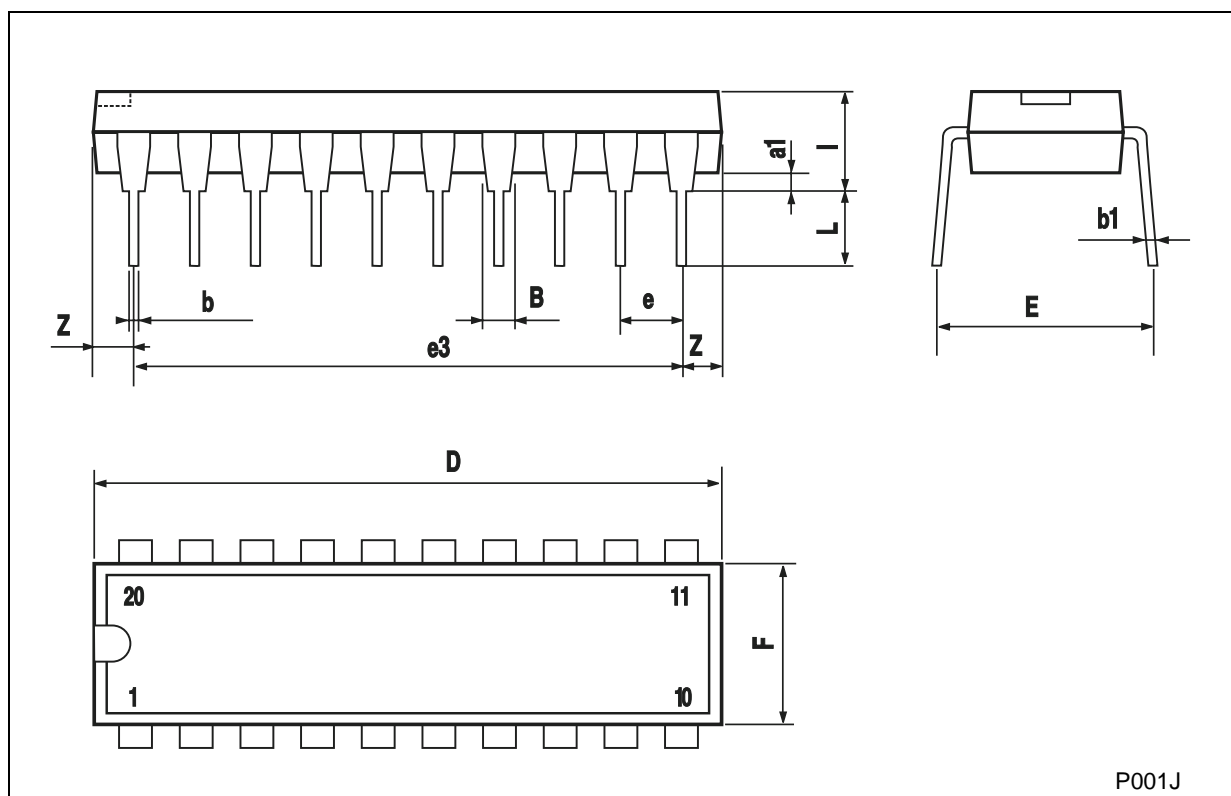

## SO-20 MECHANICAL DATA

DIM.	mm.			inch		
	MIN.	TYP	MAX.	MIN.	TYP.	MAX.
A			2.65			0.104
a1	0.1		0.2	0.004		0.008
a2			2.45			0.096
b	0.35		0.49	0.014		0.019
b1	0.23		0.32	0.009		0.012
C		0.5			0.020	
c1	45° (typ.)					
D	12.60		13.00	0.496		0.512
E	10.00		10.65	0.393		0.419
e		1.27			0.050	
e3		11.43			0.450	
F	7.40		7.60	0.291		0.300
L	0.50		1.27	0.020		0.050
M			0.75			0.029
S	8° (max.)					

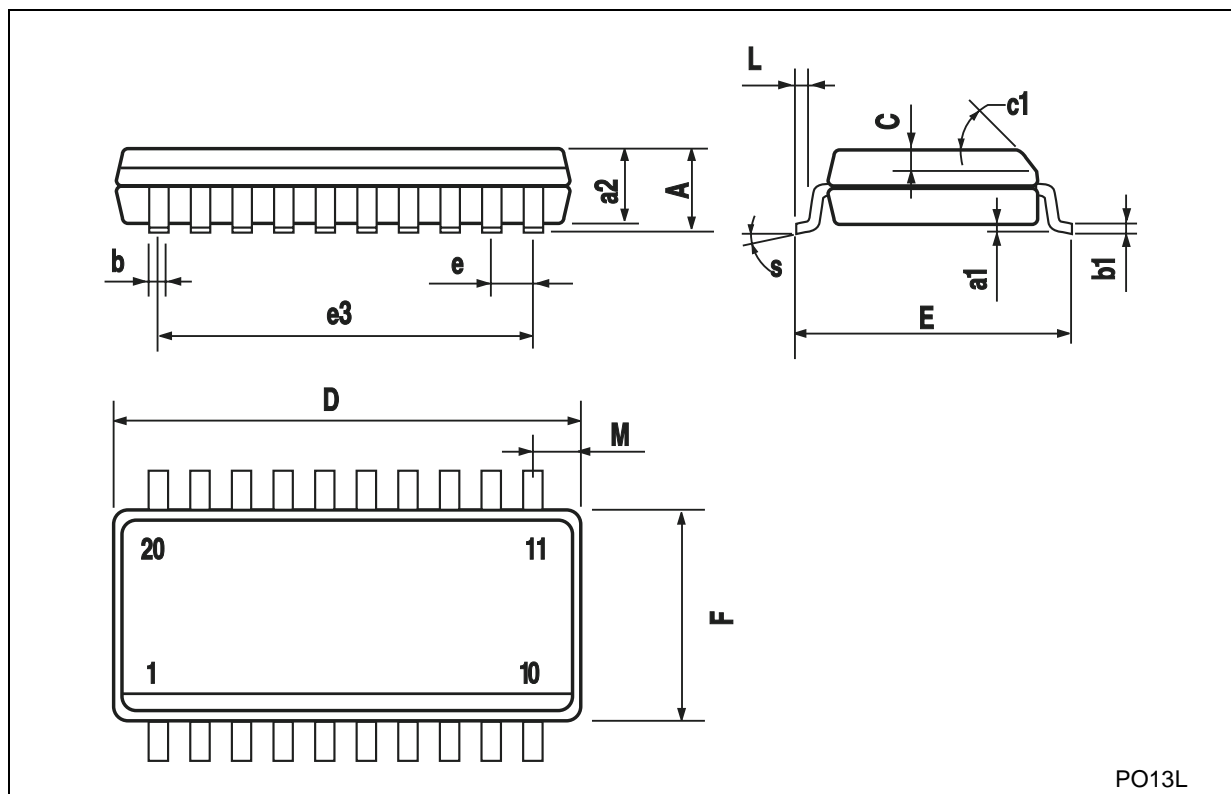



## TSSOP20 MECHANICAL DATA

DIM.	mm.			inch		
	MIN.	TYP	MAX.	MIN.	TYP.	MAX.
A			1.2			0.047
A1	0.05		0.15	0.002	0.004	0.006
A2	0.8	1	1.05	0.031	0.039	0.041
b	0.19		0.30	0.007		0.012
c	0.09		0.20	0.004		0.0089
D	6.4	6.5	6.6	0.252	0.256	0.260
E	6.2	6.4	6.6	0.244	0.252	0.260
E1	4.3	4.4	4.48	0.169	0.173	0.176
e		0.65 BSC			0.0256 BSC	
K	0°		8°	0°		8°
L	0.45	0.60	0.75	0.018	0.024	0.030

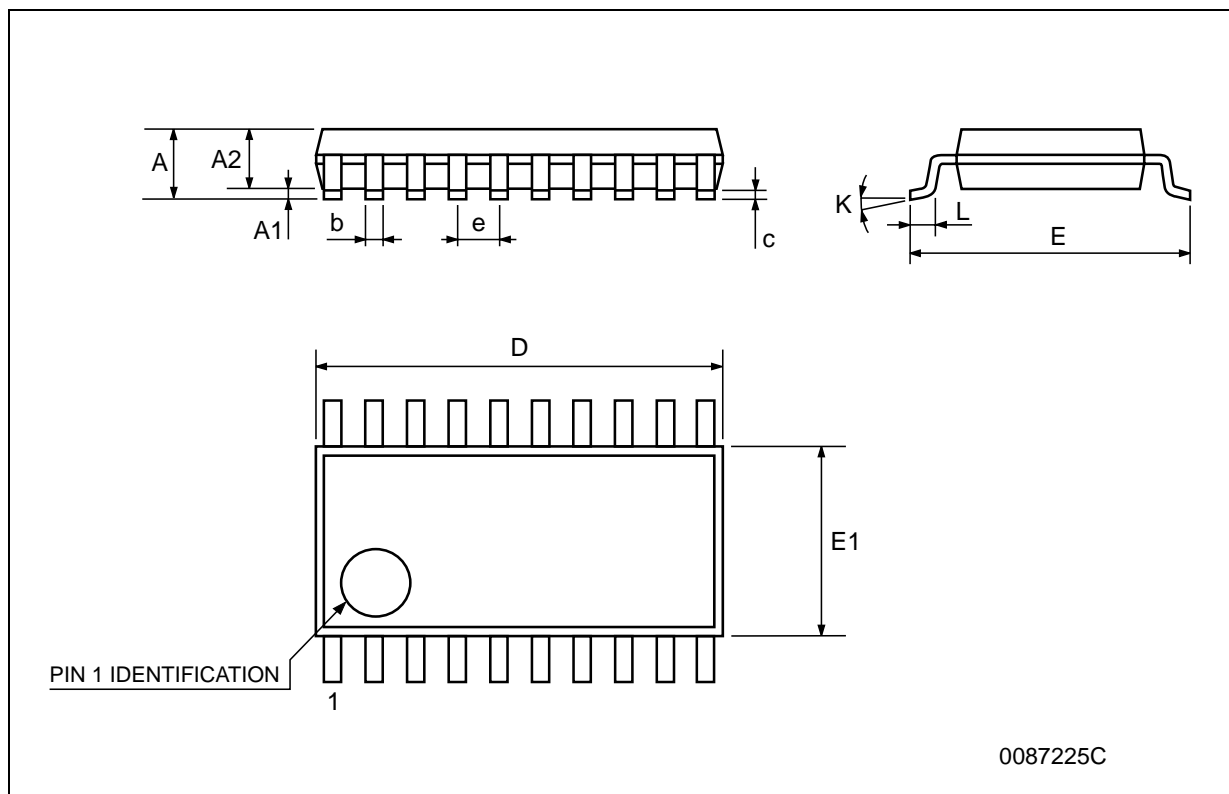

Information furnished is believed to be accurate and reliable. However, STMicroelectronics assumes no responsibility for the consequences of use of such information nor for any infringement of patents or other rights of third parties which may result from its use. No license is granted by implication or otherwise under any patent or patent rights of STMicroelectronics. Specifications mentioned in this publication are subject to change without notice. This publication supersedes and replaces all information previously supplied. STMicroelectronics products are not authorized for use as critical components in life support devices or systems without express written approval of STMicroelectronics.

© The ST logo is a registered trademark of STMicroelectronics

© 2001 STMicroelectronics - Printed in Italy - All Rights Reserved  
STMicroelectronics GROUP OF COMPANIES

Australia - Brazil - China - Finland - France - Germany - Hong Kong - India - Italy - Japan - Malaysia - Malta - Morocco  
Singapore - Spain - Sweden - Switzerland - United Kingdom

© <http://www.st.com>