



February 1988

## CD4041UB/CD4041UBC Quad True/Complement Buffer

### General Description

The CD4041UB/CD4041UBC is a quad true/complement buffer consisting of N- and P-channel enhancement mode transistors having low-channel resistance and high current (sourcing and sinking) capability. The CD4041 is intended for use as a buffer, line driver, or CMOS-to-TTL driver.

All inputs are protected from static discharge by diode clamps to  $V_{DD}$  and  $V_{SS}$ .

### Features

- Wide supply voltage range 3.0V to 15V
- High noise immunity 40%  $V_{DD}$  (typ.)
- True output
  - High current source and sink capability
  - 8 mA (typ.) @  $V_O = 9.5V, V_{DD} = 10V$
  - 3.2 mA (typ.) @  $V_O = 0.4V, V_{DD} = 5V$  (two TTL loads)
- Complement output
  - Medium current source and sink capability
  - 3.6 mA (typ.) @  $V_O = 9.5V, V_{DD} = 10V$
  - 1.6 mA (typ.) @  $V_O = 0.4V, V_{DD} = 5V$

### Connection and Schematic Diagrams

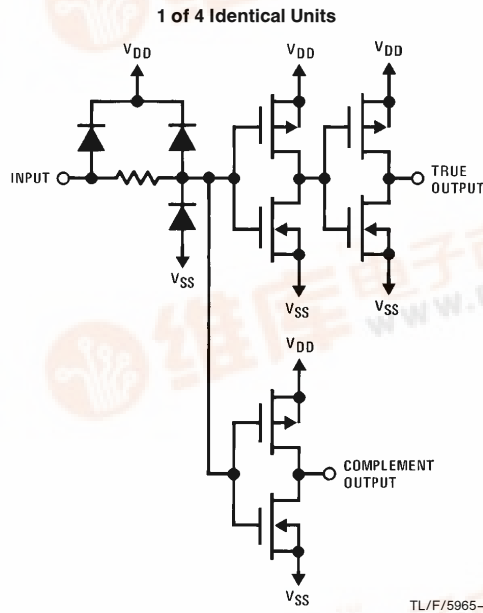
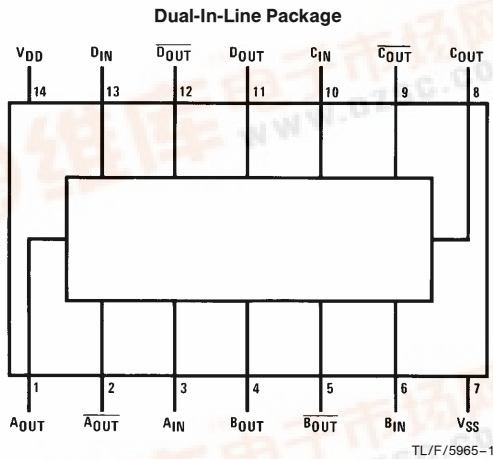

CD4041UB/CD4041UBC Quad True/Complement Buffer



## Absolute Maximum Ratings (Notes 1 and 2)

If Military/Aerospace specified devices are required, please contact the National Semiconductor Sales Office/Distributors for availability and specifications.

Supply Voltage ( $V_{DD}$ )	–0.5V to +18V
Input Voltage ( $V_{IN}$ )	–0.5V to $V_{DD}$ + 0.5V
Storage Temperature Range ( $T_S$ )	–65°C to +150°C
Power Dissipation ( $P_D$ )	
Dual-In-Line	700 mW
Small Outline	500 mW
Lead Temp. ( $T_L$ ) (Soldering, 10 sec.)	260°C

## Recommended Operating Conditions (Note 2)

Supply Voltage ( $V_{DD}$ )	3V to 15V
Input Voltage ( $V_{IN}$ )	0V to $V_{DD}$
Operating Temperature Range ( $T_A$ )	
CD4041UB	–55°C to +125°C
CD4041UBC	–40°C to +85°C

## DC Electrical Characteristics CD4041UBM (Note 2)

Symbol	Parameter	Conditions	–55°C		+25°C			+125°C		Units
			Min	Max	Min	Typ	Max	Min	Max	
$I_{DD}$	Quiescent Device Current	$V_{DD} = 5V$		1		0.01	1		30	$\mu A$
		$V_{DD} = 10V$		2		0.01	2		60	$\mu A$
		$V_{DD} = 15V$		4		0.01	4		120	$\mu A$
$V_{OL}$	Low Level Output Voltage	$ I_O  < 1 \mu A, V_{IL} = 0V, V_{IH} = V_{DD}$								
		$V_{DD} = 5V$		0.05		0	0.05		0.05	V
		$V_{DD} = 10V$		0.05		0	0.05		0.05	V
$V_{OH}$	High Level Output Voltage	$ I_O  < 1 \mu A, V_{IL} = 0V, V_{IH} = V_{DD}$								
		$V_{DD} = 5V$	4.95		4.95	5		4.95		V
		$V_{DD} = 10V$	9.95		9.95	10		9.95		V
$V_{IL}$	Low Level Input Voltage	$ I_O  < 1 \mu A$								
		$V_{DD} = 5V, V_O = 0.5V$ or 4.5V		1.0		2	1.0		1.0	V
		$V_{DD} = 10V, V_O = 1V$ or 9V		2.0		4	2.0		2.0	V
$V_{IH}$	High Level Input Voltage	$ I_O  < 1 \mu A$								
		$V_{DD} = 5V, V_O = 0.5V$ or 4.5V	4.0		4.0	3		4.0		V
		$V_{DD} = 10V, V_O = 1V$ or 9V	8.0		8.0	6		8.0		V
$I_{OL}$	Low Level Output Current True Output (Note 3)	$V_{IL} = 0V$								
		$V_{DD} = 5V, V_O = 0.4V$	2.1		1.6	3.2		1.2		mA
		$V_{DD} = 10V, V_O = 0.5V$	6.25		5.0	10		3.5		mA
$I_{OH}$	High Level Output Current True Output (Note 3)	$V_{IH} = V_{DD}$								
		$V_{DD} = 5V, V_O = 4.6V$	–1.75		–1.4	–2.8		–1.0		mA
		$V_{DD} = 10V, V_O = 9.5V$	–5.0		–4	–8.0		–2.8		mA
$I_{OH}$	High Level Output Current Complement Output (Note 3)	$V_{IL} = 0V$								
		$V_{DD} = 5V, V_O = 4.6V$	–0.75		–0.6	–1.2		–0.4		mA
		$V_{DD} = 10V, V_O = 9.5V$	–2.25		–1.8	–3.6		–1.25		mA
$I_{IN}$	Input Current	$V_{DD} = 15V, V_{IN} = 0V$		–0.1		$–10^{-5}$	–0.1		–1.0	$\mu A$
		$V_{DD} = 15V, V_{IN} = 15V$		0.1		$10^{-5}$	0.1		1.0	$\mu A$

**Note 1:** "Absolute Maximum Ratings" are those values beyond which the safety of the device cannot be guaranteed. They are not meant to imply that the devices should be operated at these limits. The tables of "Recommended Operating Conditions" and "Electrical Characteristics" provide conditions for actual device operation.

**Note 2:**  $V_{SS} = 0V$  unless otherwise specified.

**Note 3:**  $I_{OH}$  and  $I_{OL}$  are tested one output at a time.

## DC Electrical Characteristics CD4041UBC (Note 2)

Symbol	Parameter	Conditions	-40°C		+25°C			+85°C		Units
			Min	Max	Min	Typ	Max	Min	Max	
I <sub>DD</sub>	Quiescent Device Current	V <sub>DD</sub> = 5V		4		0.01	4		30	μA
		V <sub>DD</sub> = 10V		8		0.01	8		60	μA
		V <sub>DD</sub> = 15V		16		0.01	16		120	μA
V <sub>OL</sub>	Low Level Output Voltage	I <sub>O</sub>   < 1 μA, V <sub>IL</sub> = 0V, V <sub>IH</sub> = V <sub>DD</sub>								
		V <sub>DD</sub> = 5V		0.05		0	0.05		0.05	V
		V <sub>DD</sub> = 10V		0.05		0	0.05		0.05	V
V <sub>OH</sub>	High Level Output Voltage	I <sub>O</sub>   < 1 μA, V <sub>IL</sub> = 0V, V <sub>IH</sub> = V <sub>DD</sub>								
		V <sub>DD</sub> = 5V	4.95		4.95	5		4.95		V
		V <sub>DD</sub> = 10V	9.95		9.95	10		9.95		V
V <sub>IH</sub>	High Level Input Voltage	I <sub>O</sub>   < 1 μA								
		V <sub>DD</sub> = 5V, V <sub>O</sub> = 0.5V or 4.5V		1.0		2	1.0		1.0	V
		V <sub>DD</sub> = 10V, V <sub>O</sub> = 1V or 9V		2.0		4	2.0		2.0	V
V <sub>OL</sub>	Low Level Input Voltage	V <sub>DD</sub> = 15V, V <sub>O</sub> = 1.5V or 13.5V		3.0		6	3.0		3.0	V
		V <sub>DD</sub> = 5V, V <sub>O</sub> = 0.5V or 4.5V	4.0		4.0	3		4.0		V
		V <sub>DD</sub> = 10V, V <sub>O</sub> = 1V or 9V	8.0		8.0	6		8.0		V
I <sub>OL</sub>	Low Level Output Current True Output (Note 3)	V <sub>IL</sub> = 0V								
		V <sub>DD</sub> = 5V, V <sub>O</sub> = 0.4V	1.7		1.5	3.2		1.2		mA
		V <sub>DD</sub> = 10V, V <sub>O</sub> = 0.5V	4.9		4.3	10		3.5		mA
I <sub>OL</sub>	Low Level Output Current Complement Output (Note 3)	V <sub>DD</sub> = 15V, V <sub>O</sub> = 1.5V	11		10	24		8		mA
		V <sub>IH</sub> = V <sub>DD</sub>								
		V <sub>DD</sub> = 5V, V <sub>O</sub> = 0.4V	0.75		0.68	1.6		0.55		mA
I <sub>OH</sub>	High Level Output Current True Output (Note 3)	V <sub>DD</sub> = 10V, V <sub>O</sub> = 9.5V	2.0		1.8	4.0		1.4		mA
		V <sub>DD</sub> = 15V, V <sub>O</sub> = 1.5V	4.4		3.8	9.0		3.0		mA
		V <sub>DD</sub> = 5V, V <sub>O</sub> = 4.6V	-1.5		-1.3	-2.8		-1.0		mA
I <sub>OH</sub>	High Level Output Current Complement Output (Note 3)	V <sub>DD</sub> = 10V, V <sub>O</sub> = 9.5V	-4.0		-3.5	-8.0		-2.8		mA
		V <sub>DD</sub> = 15V, V <sub>O</sub> = 13.5V	-8.7		-7.5	-18		-6		mA
		V <sub>IL</sub> = 0V	-0.57		-0.50	-1.2		-0.4		mA
I <sub>IN</sub>	Input Current	V <sub>DD</sub> = 5V, V <sub>O</sub> = 4.6V	-1.8		-1.6	-3.6		-1.25		mA
		V <sub>DD</sub> = 10V, V <sub>O</sub> = 9.5V	-3.9		-3.4	-8.0		-2.7		mA
		V <sub>DD</sub> = 15V, V <sub>O</sub> = 13.5V								
I <sub>IN</sub>	Input Current	V <sub>DD</sub> = 15V, V <sub>IN</sub> = 0V		-0.3		-10 <sup>-5</sup>	-0.3		-1.0	μA
		V <sub>DD</sub> = 15V, V <sub>IN</sub> = 15V		0.3		10 <sup>-5</sup>	0.3		1.0	μA

## AC Electrical Characteristics\*

T<sub>A</sub> = 25°C, C<sub>L</sub> = 50 pF, R<sub>L</sub> = 200k, Input t<sub>r</sub> = t<sub>f</sub> = 20 ns, unless otherwise specified

Symbol	Parameter	Conditions	Min	Typ	Max	Units
t <sub>PHL</sub> , t <sub>PLH</sub>	Propagation Delay Time True Output	V <sub>DD</sub> = 5V		60	120	ns
		V <sub>DD</sub> = 10V		35	70	ns
		V <sub>DD</sub> = 15V		25	50	ns
t <sub>PHL</sub> , t <sub>PLH</sub>	Propagation Delay Time Complement Output	V <sub>DD</sub> = 5V		75	150	ns
		V <sub>DD</sub> = 10V		40	80	ns
		V <sub>DD</sub> = 15V		30	65	ns
t <sub>THL</sub> , t <sub>TLH</sub>	Output Transition Time True Output	V <sub>DD</sub> = 5V		55	110	ns
		V <sub>DD</sub> = 10V		30	60	ns
		V <sub>DD</sub> = 15V		25	50	ns

## AC Electrical Characteristics\* (Continued)

$T_A = 25^\circ\text{C}$ ,  $C_L = 50\text{ pF}$ ,  $R_L = 200\text{ k}$ , Input  $t_r = t_f = 20\text{ ns}$ , unless otherwise specified

Symbol	Parameter	Conditions	Min	Typ	Max	Units
$t_{THL}$ , $t_{TLH}$	Output Transition Time Complement Output	$V_{DD} = 5\text{V}$ $V_{DD} = 10\text{V}$ $V_{DD} = 15\text{V}$		90 45 35	180 90 75	ns
$C_{IN}$	Input Capacitance	Any Input		10	15	pF

\*AC Parameters are guaranteed by DC correlated testing.

**Note 1:** "Absolute Maximum Ratings" are those values beyond which the safety of the device cannot be guaranteed. They are not meant to imply that the devices should be operated at these limits. The tables of "Recommended Operating Conditions" and "Electrical Characteristics" provide conditions for actual device operation.

**Note 2:**  $V_{SS} = 0\text{V}$  unless otherwise specified.

**Note 3:**  $I_{OH}$  and  $I_{OL}$  are tested one output at a time.

## Switching Time Waveforms

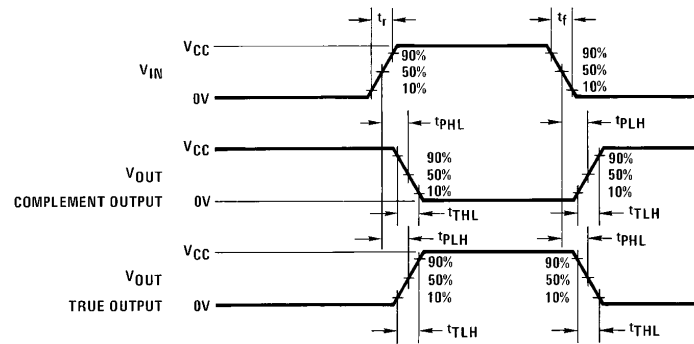

TL/F/5965-3

**Physical Dimensions** inches (millimeters)

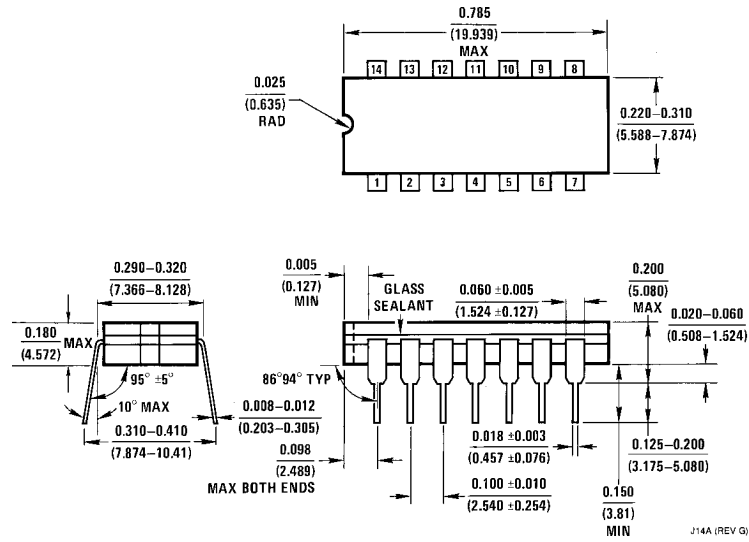

**Ceramic Dual-In-Line Package (J)**  
**Order Number CD4041UBMJ or CD4041UBCJ**  
**NS Package Number J14A**

J14A (REV G)

**Physical Dimensions** inches (millimeters) (Continued)

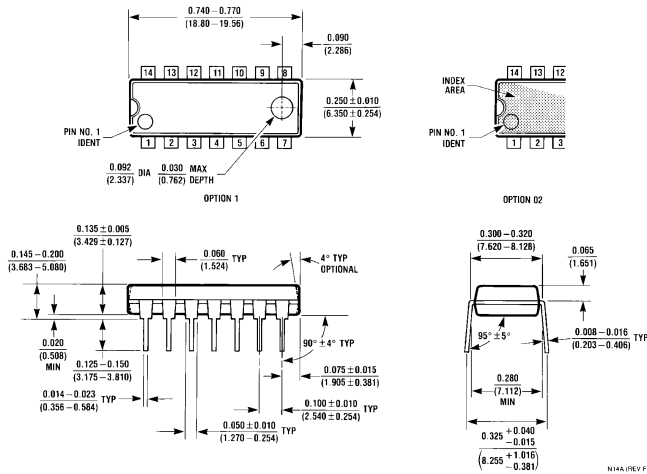

**Molded Dual-In-Line Package (N)**  
**Order Number CD4041UBN or CD4041UBCN**  
**NS Package Number N14A**

**LIFE SUPPORT POLICY**

NATIONAL'S PRODUCTS ARE NOT AUTHORIZED FOR USE AS CRITICAL COMPONENTS IN LIFE SUPPORT DEVICES OR SYSTEMS WITHOUT THE EXPRESS WRITTEN APPROVAL OF THE PRESIDENT OF NATIONAL SEMICONDUCTOR CORPORATION. As used herein:

1. Life support devices or systems are devices or systems which, (a) are intended for surgical implant into the body, or (b) support or sustain life, and whose failure to perform, when properly used in accordance with instructions for use provided in the labeling, can be reasonably expected to result in a significant injury to the user.
2. A critical component is any component of a life support device or system whose failure to perform can be reasonably expected to cause the failure of the life support device or system, or to affect its safety or effectiveness.



**National Semiconductor Corporation**  
 1111 West Bardin Road  
 Arlington, TX 76017  
 Tel: 1(800) 272-9959  
 Fax: 1(800) 737-7018

**National Semiconductor Europe**  
 Fax: (+49) 0-180-530 85 86  
 Email: cnjwge@tevm2.nsc.com  
 Deutsch Tel: (+49) 0-180-530 85 85  
 English Tel: (+49) 0-180-532 78 32  
 Français Tel: (+49) 0-180-532 93 58  
 Italiano Tel: (+49) 0-180-534 16 80

**National Semiconductor Hong Kong Ltd.**  
 13th Floor, Straight Block,  
 Ocean Centre, 5 Canton Rd.  
 Tsimshatsui, Kowloon  
 Hong Kong  
 Tel: (852) 2737-1600  
 Fax: (852) 2736-9960

**National Semiconductor Japan Ltd.**  
 Tel: 81-043-299-2309  
 Fax: 81-043-299-2408