



**Integrated
Circuit
Systems, Inc.**

ICS9147-09

Frequency Generator & Integrated Buffers for 686 Series CPUs

General Description

The ICS9147-09 generates all clocks required for high speed RISC or CISC microprocessor systems such as Intel PentiumPro, AMD or Cyrix processors. Four bidirectional I/O pins (FS0, FS1, FS2, BSEL) are latched at power-on to the functionality table. The Six BUS clocks can be selected as either synchronous at 1/2 CPU speed or asynchronous at 32MHz selected by BSEL latched input. The inputs provide for tristate and test mode conditions to aid in system level testing. These multiplying factors can be customized for specific applications. Glitch-free stop clock controls provided for CPU.

High drive BUS and SDRAM outputs typically provide greater than 1 V/ns slew rate into 30 pF loads. CPU outputs typically provide better than 1V/ns slew rate into 20pF loads while maintaining 50±5% duty cycle. The REF clock outputs typically provide better than 0.5V/ns slew rates. Separate buffer supply pin VDDL allows for nominal 3.3V voltage or reduced voltage swing (from 2.9 to 2.5V) for CPUL (1:2) and IOAPIC outputs.

Features

- Total of 15 CPU speed clocks:
 - Two copies of CPU clock with VDDL (2.5 to 3.3V)
 - Twelve (12) SDRAM (3.3v) plus one CPUH/AGP (3.3V) clocks
- Six copies of BUS clock (synchronous with CPU clock/2 or asynchronous 32 MHz)
- 250ps output skew window for CPU and SDRAM clocks and 500ps window BUS clocks. CPU clocks to BUS clocks skew 1-4ns (CPU early)
- Two copies of Ref. clock @14.31818 MHz (One driven by VDDL as IOAPIC)
- One 48 MHz (3.3 V TTL) for USB support and single 24 MHz.
- Separate VDDL for CPUL (1:2) clock buffers and IOAPIC to allow 2.5V output (or Std. Vdd)
- 3.0V – 3.7V supply range w/2.5V compatible outputs
- 48-pin SSOP package

Block Diagram

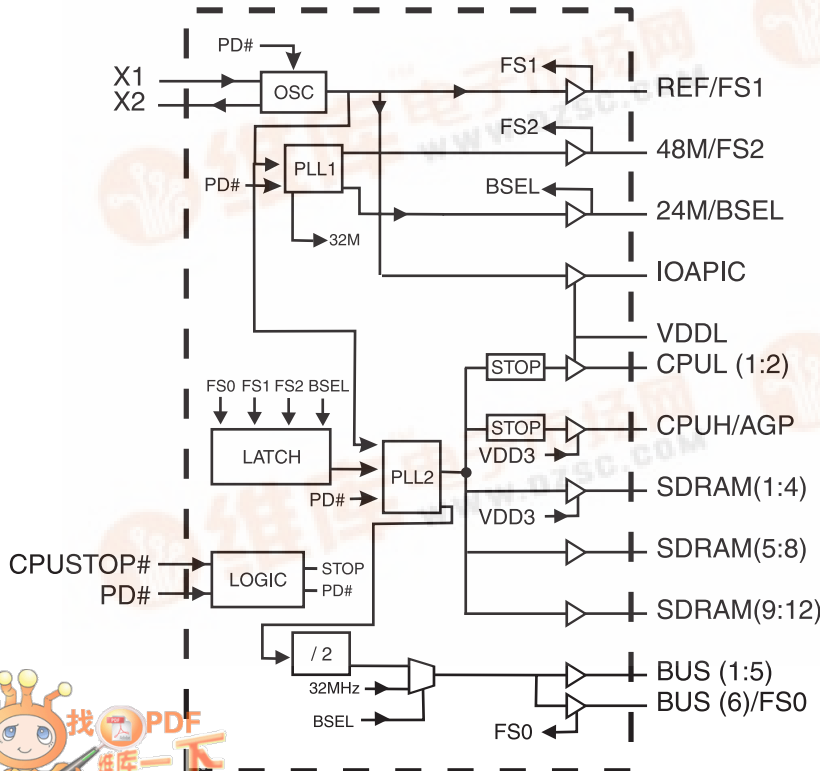

Pin Configuration

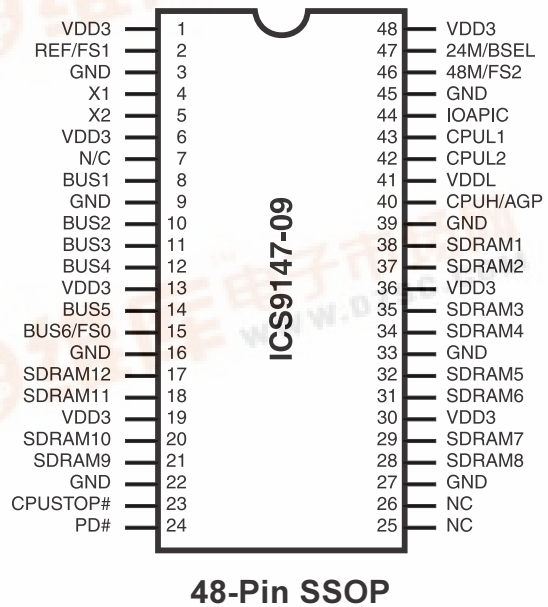

ICS9147-09



Pin Descriptions

PIN NUMBER	PIN NAME	TYPE	DESCRIPTION
2	REF	OUT	Reference clock output*
	FS1	IN	Logic input frequency select Bit1*. Input latched at Poweron.
3, 9, 16, 22, 27, 33, 39, 45	GND	PWR	Ground.
4	X1	IN	Crystal input. Nominally 14.318 MHz. Has internal load cap
5	X2	OUT	Crystal output. Has internal load cap and feedback resistor to X1
41	VDDL	PWR	2.5 or 3.3V buffer power for CPUL and IOAPIC output buffers.
8, 10, 11, 12, 14,	BUS (1:5)	OUT	BUS clock outputs. see select table for frequency
15	BUS6	OUT	BUS clock output. See select table for frequency.*
	FS0	IN	Logic input frequency select Bit0.*. Input latched at Poweron.
23	CPU_STOP#	IN	Halts CPU Clocks at Logic "0" level when low. Internal Pull-up
24	PD#	IN	Powers down chip, active low. Internal Pull-up
47	24M	OUT	24MHz fixed clock.*
	BSEL	IN	Logic input* for selecting synchronous or asynchronous BUS frequency- see table above. Input latched at Poweron.*
1, 6, 13, 19, 30, 36, 48	VDD3	PWR	3.3 volt core logic and buffer power
17, 18, 20, 21, 28, 29, 31, 32, 34, 35, 37, 38	SDRAM (1:12)	OUT	SDRAM clocks at CPU speed. See select table for frequency.
40	CPUH/AGP	OUT	CPU clock operates at SDRAM VDD level (3.3V nom), for AGP etc.
42, 43	CPUL (1:2)	OUT	CPU clocks .See select table for frequency. Operates at down to 2.5V controlled by VDDL pin.
7, 25, 26	N/C	—	Pins not internally connected.
46	48M	OUT	48 MHz fixed clock output*.
	FS2	IN	Logic input frequency select Bit 2*. Input latched at Poweron.
44	IOAPIC	OUT	Reference clock (14.318MHz) powered by VDDL, operating 2.5 to 3.3V.

* Bidirectional input/output pins, input logic level determined at internal power-on-reset are latched. Use 10Kohm resistor to program logic Hi to VDD or GND for logic low.

ICS9147-09



Absolute Maximum Ratings

Supply Voltage	7.0V
Logic Inputs	GND-0.5V to V _{DD} +0.5V
Ambient Operating Temperature	0°C to +70°C
Storage Temperature	-65°C to +150°C

Stresses above those listed under *Absolute Maximum Ratings* may cause permanent damage to the device. These ratings are stress specifications only and functional operation of the device at these or any other conditions above those listed in the operational sections of the specifications is not implied. Exposure to absolute maximum rating conditions for extended periods may affect product reliability.

Electrical Characteristics at 3.3V

V_{DD} = 3.0 – 3.7V, T_A = 0 – 70°C unless otherwise stated

DC Characteristics						
PARAMETER	SYMBOL	TEST CONDITIONS	MIN	TYP	MAX	UNITS
Input Low Voltage	V _{IL}	Latched inputs and Fulltime inputs	-	-	0.2V _{DD}	V
Input High Voltage	V _{IH}	Latched inputs and Fulltime inputs	0.7V _{DD}	-	-	V
Input Low Current	I _{IL}	V _{IN} = 0V (Fulltime inputs)	-28.0	-10.5	-	μA
Input High Current	I _{IH}	V _{IN} =V _{DD} (Fulltime inputs)	-5.0	-	5.0	μA
Output Low Current	I _{OL1a}	V _{OL} = 0.8V; CPU, SDRAM IOAPIC, REF, BUS; V _{DD2} = 3.3V	19.0	30.0	-	mA
	I _{OL1b}	V _{OL} = 0.8V; CPUL, IOAPIC; V _{DD2} = 2.5V	19.0	30.0	-	mA
Output High Current	I _{OH1a}	V _{OH} = 2.0V; CPU, SDRAM IOAPIC, REF, BUS; V _{DD2} = 3.3V	-	-26.0	-16.0	mA
	I _{OH1b}	V _{OH} = 2.0V; CPUL, IOAPIC; V _{DD2} = 2.5V	-	-12.5	-9.5	mA
Output Low Current	I _{OL2}	V _{OL} = 0.8V; for fixed 24, 48	16.0	25.0	-	mA
Output High Current	I _{OH2}	V _{OH} = 2.0V; for fixed 24, 48	-	-22.0	-14.0	mA
Output Low Voltage	V _{OL1a}	I _{OL} = 10mA; CPU, SDRAM IOAPIC REF, BUS; V _{DD2} = 3.3V	-	0.3	0.4	V
	V _{OL1b}	I _{OL} = 10mA; CPUL, IOAPIC; V _{DD2} =2.5V	-	0.3	0.4	V
Output High Voltage	V _{OH1a}	I _{OH} = -10mA; CPU, SDRAM, IOAPIC, REF, BUS; V _{DD} = 3.3V	2.4	2.8	-	V
	V _{OH1b}	I _{OH} = -10mA; CPUL, IOAPIC; V _{DD2} =2.5V	1.95	2.1	-	V
Output Low Voltage	V _{OL2}	I _{OL} = 8mA; for fixed 24, 48MHz CLKs	-	0.3	0.4	V
Output High Voltage	V _{OH2}	I _{OH} = -8mA; for fixed 24, 48MHz CLKs	2.4	2.8	-	V
Supply Current	I _{DD}	@66.6 MHz; all outputs unloaded	-	120	180	mA
Power Down Current	I _{pd}	PD#=-0	-	5.0	20.0	μA
Pull-up Resistor	R _{pu}	CPUSTOP#; PD#	20	40	80	Kohms

Note 1: Parameter is guaranteed by design and characterization. Not 100% tested in production.



Electrical Characteristics at 3.3V

V_{DD} = 3.0 – 3.7 V, T_A = 0 – 70° C unless otherwise stated

AC Characteristics						
PARAMETER	SYMBOL	TEST CONDITIONS	MIN	TYP	MAX	UNITS
Rise Time ¹	Tr1	20pF load, 0.8 to 2.0V CPU, SDRAM, BUS & REF	-	0.9	1.5	ns
Fall Time ¹	Tf1	20pF load, 2.0 to 0.8V CPU, SDRAM, BUS & REF	-	0.8	1.4	ns
Rise Time ¹	Tr3	20pF load, 0.8 to 2.0V fixed 20 & 48 clocks	-	0.9	1.5	ns
Fall Time ¹	Tf3	20pF load, 2.0 to 0.8V fixed 20 & 48 clocks	-	1.1	1.5	ns
Rise Time ¹	Tr4	20pF load, 0.4 to 2.0V, CPUL with VDDL = 2.5V	-	2.0	2.5	ns
Fall Time ¹	Tf4	20pF load, 2.0 to 0.4V, CPUL with VDDL = 2.5V	-	1.6	2.5	ns
Duty Cycle ¹	Dt	20pF load @ VOUT=1.4V All clocks except 48MHz and REF	47	52	57	%
Duty Cycle ¹	DT2	20pF load @ VOUT=1.4V 48MHz and REF outputs	40	50	60	%
Jitter, One Sigma ¹	Tjis1	CPU & BUS Clocks; Load=20pF, SDRAM; Load = 30pF, VDDL = 3.3 or 2.5V FOUT=25 MHz, BSEL=1	-	50	150	ps
Jitter, Absolute ¹	Tjab1	CPU & BUS Clocks; Load=20pF, SDRAM; Load = 30pF, VDDL = 3.3 or 2.5V FOUT≥25 MHz, BSEL=1	-250	-	250	ps
Jitter, One Sigma ¹	Tjis2	Fixed CLK; Load=20pF	-	1	3	%
Jitter, Absolute ¹	Tjab2	Fixed CLK; Load=20pF	-5	2	5	%
Jitter, Cycle to Cycle ¹	Tcc1	CPU Clocks, Load=20pF BSEL=1		-	250	ps
Jitter, Cycle to Cycle ¹	Tcc2	CPU Clocks, Load=20pF BSEL=1 VDDL=2.5V		-	350	ps
Input Frequency ¹	Fi		12.0	14.318	16.0	MHz
Ratio of nominal to output frequency	Fout1	With input driven at 14.31818MHz to 20.0, 48.0MHz	-1	-0.1	+1	ppm
Logic Input Capacitance ¹	CIN	Logic input pins	-	5	-	pF
Crystal Oscillator Capacitance ^{1, 2}	CINX	X1, X2 pins	2	4	6	pF
Power-on Time ¹	ton	From VDD=1.6V to 1st crossing of 66.6 MHz VDD supply ramp < 40ms	-	2.5	4.5	ms
Clock Skew Window ¹	Tsk1	CPU to CPU or SDRAM; Load=20pF; @1.4V (Same VDD)	-	150	250	ps
Clock Skew Window ¹	Tsk2	BUS to BUS, SDRAM to SDRAM; Load=20pF; @1.4V	-	300	500	ps
Clock Skew Window ¹	Tsk3	CPU to BUS; Load=20pF; @1.4V (CPU is early)	1.6	2.1	4.6	ns
Clock Skew Window ¹	Tsk4	CPUL to BUS, VDDL=2.5V Vth=1.25, CPUL (BUS Vth=1.4V)	0.50	1.50	3.0	ns
Clock Skew Window ¹	Tsk5	SDRAM, CPUH (@3.3V, Vth=1.4V) to CPUL (@2.5V Vth=1.25V) Load=20pF (2.5V CPUL is late)	100	600	850	ps

Note 1: Parameter is guaranteed by design and characterization. Not 100% tested in production.



Shared Pin Operation - Input/Output Pins

Pins 2, 15, 46 and 47 on the **ICS9147-09** serve as dual signal functions to the device. During initial power-up, they act as input pins. The logic level (voltage) that is present on these pins at this time is read and stored into a 4-bit internal data latch. At the end of Power-On reset, (see AC characteristics for timing values), the device changes the mode of operations for these pins to an output function. In this mode the pins produce the specified buffered clocks to external loads.

To program (load) the internal configuration register for these pins, a resistor is connected to either the VDD (logic 1) power supply or the GND (logic 0) voltage potential. A 10 Kilohm (10K) resistor is used to provide both the solid CMOS programming voltage needed during the power-up programming period and to provide an insignificant load on the output clock during the subsequent operating period.

Figs. 1 and 2 show the recommended means of implementing this function. In Fig. 1 either one of the resistors is loaded onto the board (selective stuffing) to configure the device's internal logic. Figs. 2a and b provide a single resistor loading option where either solder spot tabs or a physical jumper header may be used.

These figures illustrate the optimal PCB physical layout options. These configuration resistors are of such a large ohmic value that they do not effect the low impedance clock signals. The layouts have been optimized to provide as little impedance transition to the clock signal as possible, as it passes through the programming resistor pad(s).

Test Mode Operation

The **ICS9147-09** includes a production test verification mode of operation. This requires that the FS2 and FS1 pins be programmed to a logic high and the FS0 pin be programmed to a logic low (see Shared Pin Operation section). In this mode the device will output the following frequencies.

Pin		Frequency
REF, IOAPIC		REF
48MHz		REF/2
24MHz		REF/4
CPU, SDRAM		REF2
BUS	BSEL=1	REF/4
BUS	BSEL=0	REF/3

Note: REF is the frequency of either the crystal connected between the devices X1 and X2, or, in the case of a device being driven by an external reference clock, the frequency of the reference (or test) clock on the device's X1 pin.

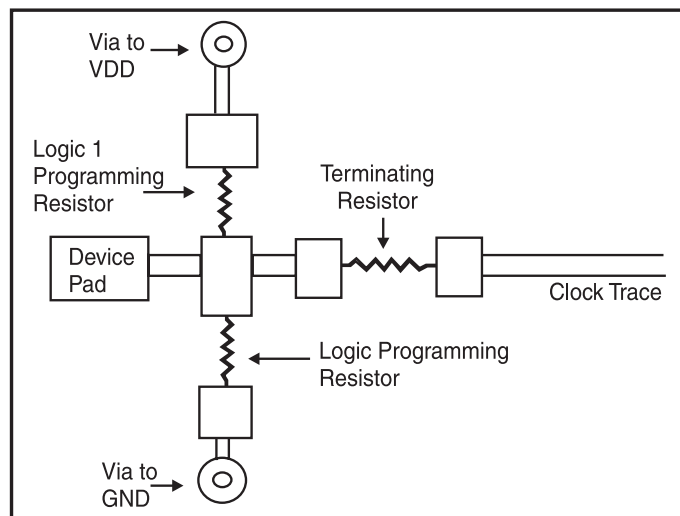

Fig. 1

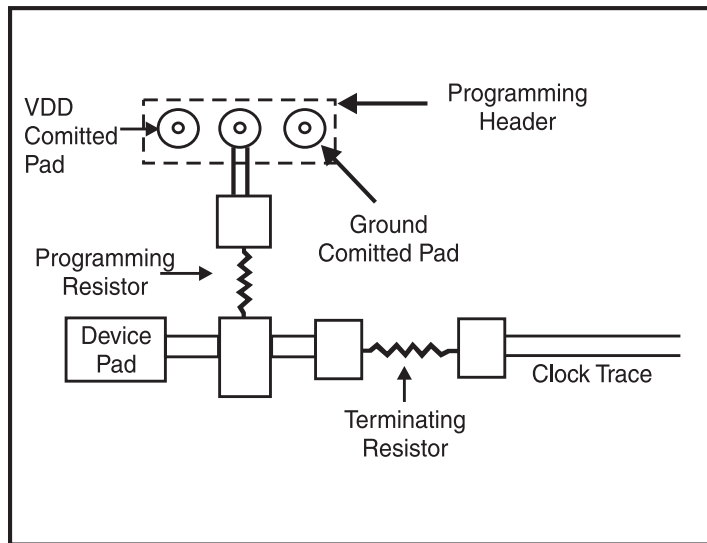

Fig. 2a

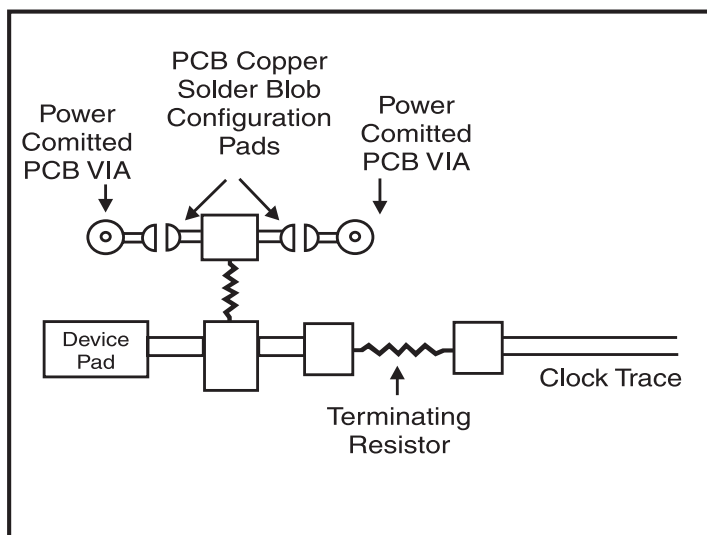
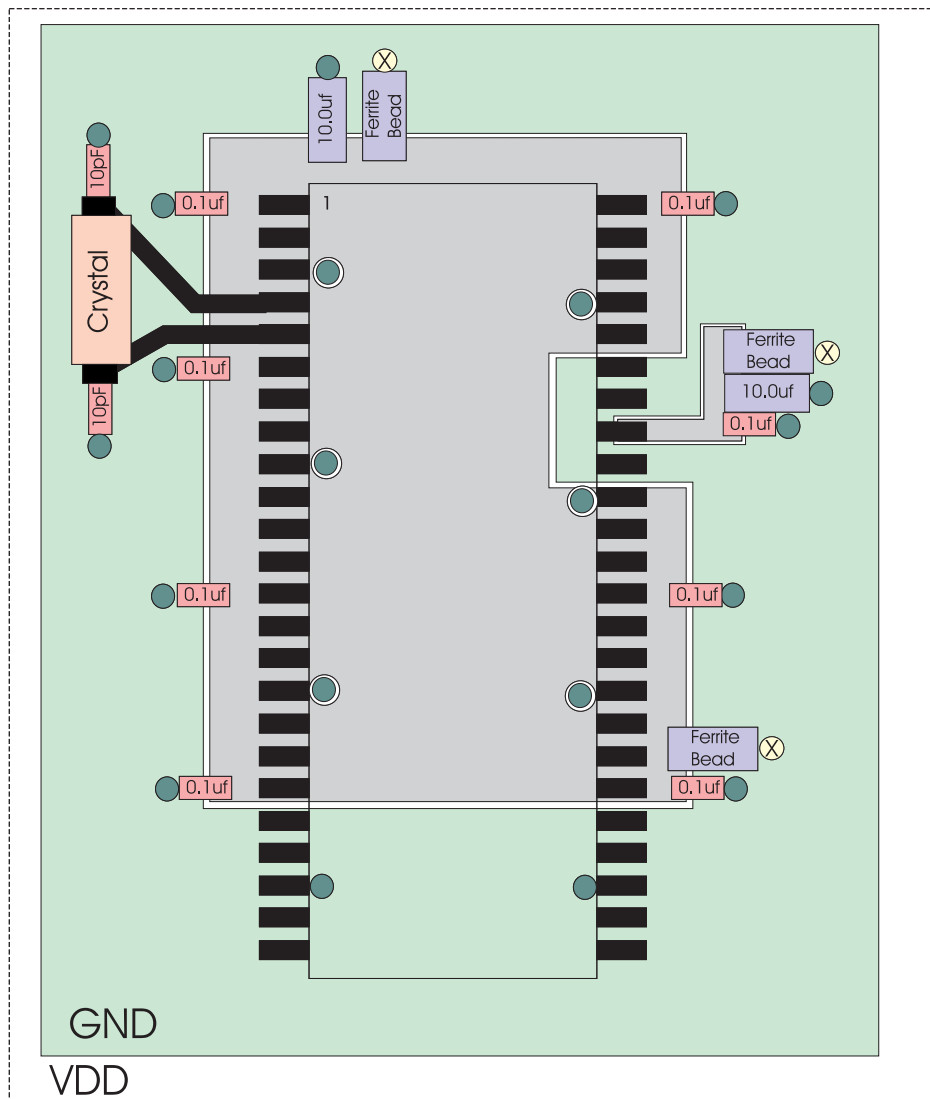

Fig. 2b



Recommended PCB Layout for ICS9147-09



- Connection to VDD plane.
- Connection to GND plane.
- ⊗ Connection to System VDD plane

NOTE:

This PCB Layout is based on a 4 layer board with an internal Ground (common) and V_{DD} plane. Placement of components will depend on routing of signal trace. The 0.1uF Capacitors should be placed as close as possible to the Power pins. Placement on the backside of the board is also possible. The Ferrite Beads can be replaced with 10-15ohm Resistors. For best results, use a Fixed Voltage Regulator between the main (board) V_{DD} and the different V_{DD} planes.

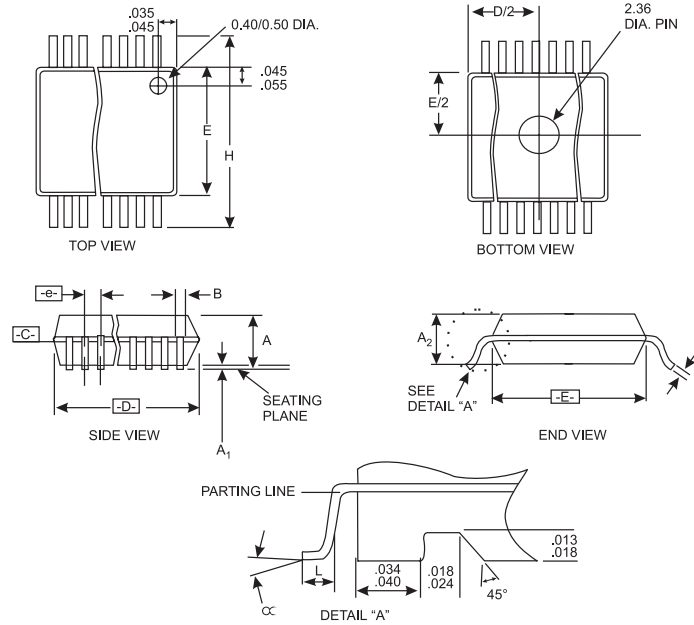

SSOP Package

SYMBOL	COMMON DIMENSIONS			VARIATIONS	D			N
	MIN.	NOM.	MAX.		MIN.	NOM.	MAX.	
A	.095	.101	.110	AC	.620	.625	.630	48
A1	.008	.012	.016	AD	.720	.725	.730	56
A2	.088	.090	.092					
B	.008	.010	.0135					
C	.005	-	.010					
D	See Variations							
E	.292	.296	.299					
e	0.025 BSC							
H	.400	.406	.410					
h	.010	.013	.016					
L	.024	.032	.040					
N	See Variations							
∞	0°	5°	8°					
X	.085	.093	.100					

Ordering Information

ICS9147F-09

Example:

ICS XXXX F - PPP

