

- Meet or Exceed the Requirements of ANSI EIA/TIA-232-E and ITU Recommendation V.28
- Designed to Be Interchangeable With Motorola MC1488
- Current-Limited Output: 10 mA Typical
- Power-Off Output Impedance: 300 Ω Minimum
- Slew Rate Control by Load Capacitor
- Flexible Supply Voltage Range
- Input Compatible With Most TTL Circuits

description

The MC1488, SN55188, and SN75188 are monolithic quadruple line drivers designed to interface data terminal equipment with data communications equipment in conformance with ANSI EIA/TIA-232-E using a diode in series with each supply-voltage terminal as shown under typical applications.

The SN55188 is characterized for operation over the full military temperature range of -55°C to 125°C. The MC1488 and SN75188 are characterized for operation from 0°C to 70°C.

FUNCTION TABLE
(drivers 2-4)

A	B	Y
H	H	L
L	X	H
X	L	H

H = high level, L = low level,
 X = irrelevant

SN55188 . . . J OR W PACKAGE
 MC1488, SN75188 . . . D OR N PACKAGE
 (TOP VIEW)

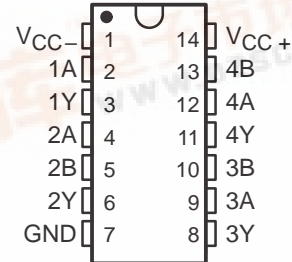

SN55188 . . . FK PACKAGE
 (TOP VIEW)

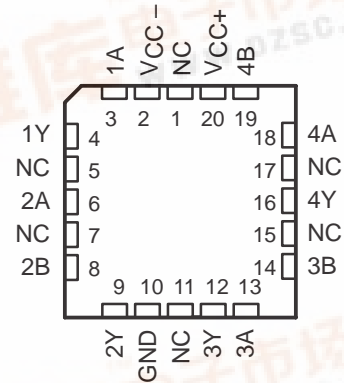

NC – No internal connection

Please be aware that an important notice concerning availability, standard warranty, and use in critical applications of Texas Instruments semiconductor products and disclaimers thereto appears at the end of this data sheet.

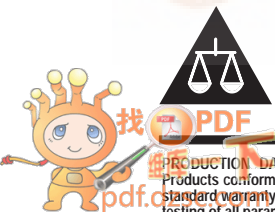

MC1488, SN55188, SN75188 QUADRUPLE LINE DRIVERS

SLLS094B – SEPTEMBER 1983 – REVISED MAY 1995

logic symbol†

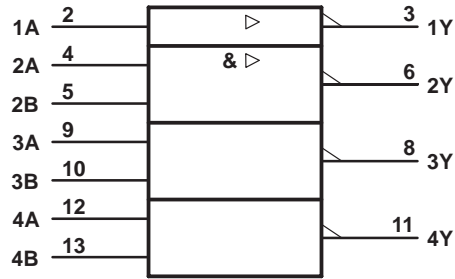

† This symbol is in accordance with ANSI/IEEE Std 91-1984 and IEC Publication 617-12.

Pin numbers shown are for the D and N packages.

logic diagram (positive logic)

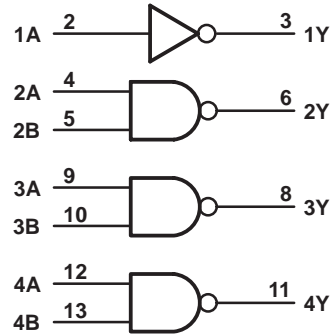

Positive logic

$$Y = \overline{A} \text{ (driver 1)}$$

$$Y = AB \text{ or } \overline{A} + \overline{B} \text{ (drivers 2 thru 4)}$$

schematic (each driver)

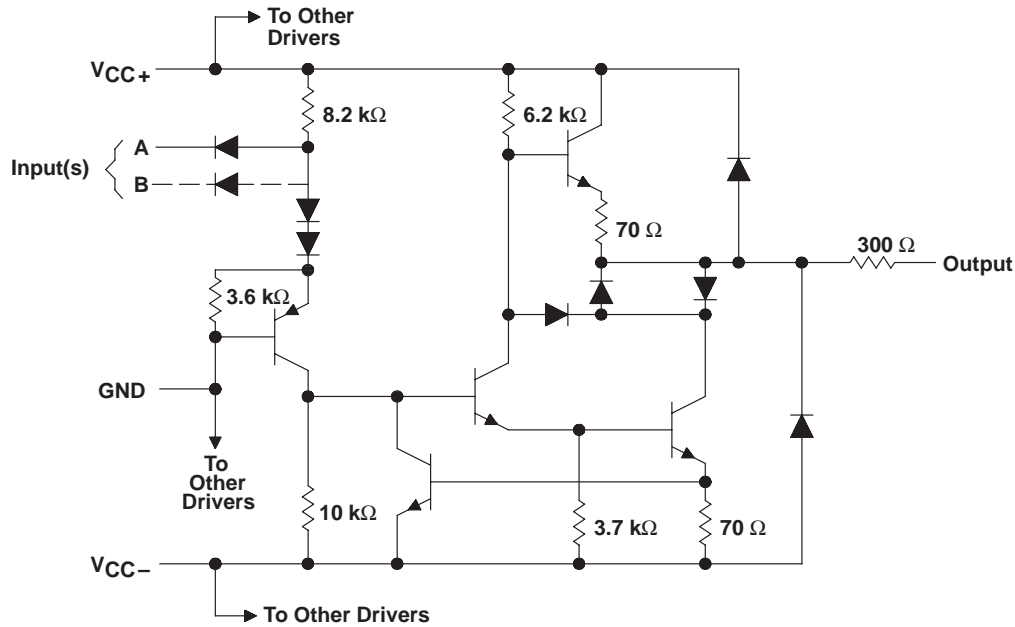

Resistor values shown are nominal.

MC1488, SN55188, SN75188 QUADRUPLE LINE DRIVERS

SLLS094B – SEPTEMBER 1983 – REVISED MAY 1995

absolute maximum ratings over operating free-air temperature (unless otherwise noted)†

Supply voltage, V_{CC+} at (or below) 25°C free-air temperature (see Notes 1 and 2)	15 V
Supply voltage, V_{CC-} at (or below) 25°C free-air temperature (see Notes 1 and 2)	-15 V
Input voltage, V_I	-15 V to 7 V
Output voltage, V_O	-15 V to 15 V
Continuous total power dissipation (see Note 2)	See Dissipation Rating Table
Operating free-air temperature range, T_A : SN55188	-55°C to 125°C
MC1488, SN75188	0°C to 70°C
Storage temperature range, T_{stg}	-65°C to 150°C
Case temperature for 60 seconds, FK package	260°C
Lead temperature 1,6 mm (1/16 inch) from case for 10 seconds: D or N package	260°C
Lead temperature 1,6 mm (1/16 inch) from case for 60 seconds: J or W package	300°C

† Stresses beyond those listed under “absolute maximum ratings” may cause permanent damage to the device. These are stress ratings only, and functional operation of the device at these or any other conditions beyond those indicated under “recommended operating conditions” is not implied. Exposure to absolute-maximum-rated conditions for extended periods may affect device reliability.

- NOTES: 1. All voltage values are with respect to the network ground terminal.
2. For operation above 25°C free-air temperature, refer to the maximum supply voltage curve, Figure 6. In the FK and J packages, SN55188 chips are alloy mounted.

DISSIPATION RATING TABLE

PACKAGE	$T_A \leq 25^\circ\text{C}$	DERATING FACTOR ABOVE $T_A = 25^\circ\text{C}$	$T_A = 70^\circ\text{C}$	$T_A = 125^\circ\text{C}$
	POWER RATING		POWER RATING	POWER RATING
D	950 mW	7.6 mW/°C	608 mW	–
FK	1375 mW	11.0 mW/°C	880 mW	275 mW
J	1375 mW	11.0 mW/°C	880 mW	275 mW
N	1150 mW	9.2 mW/°C	736 mW	–
W	1000 mW	8.0 mW/°C	640 mW	200 mW

recommended operating conditions

	SN55188			MC1488, SN75188			UNIT
	MIN	NOM	MAX	MIN	NOM	MAX	
Supply voltage, V_{CC+}	7.5	9	15	7.5	9	15	V
Supply voltage, V_{CC-}	-7.5	-9	-15	-7.5	-9	-15	V
High-level input voltage, V_{IH}	1.9			1.9			V
Low-level input voltage, V_{IL}			0.8			0.8	V
Operating free-air temperature, T_A	-55		125	0		70	°C

MC1488, SN55188, SN75188 QUADRUPLE LINE DRIVERS

SLLS094B – SEPTEMBER 1983 – REVISED MAY 1995

electrical characteristics over operating free-air temperature range, $V_{CC\pm} = \pm 9\text{ V}$ (unless otherwise noted)

PARAMETER	TEST CONDITIONS		SN55188			MC1488, SN75188			UNIT
			MIN	TYP†	MAX	MIN	TYP†	MAX	
V _{OH} High-level output voltage	V _{IL} = 0.8 V, R _L = 3 kΩ	V _{CC+} = 9 V, V _{CC-} = -9 V	6	7		6	7		V
		V _{CC+} = 13.2 V, V _{CC-} = -13.2 V	9	10.5		9	10.5		
V _{OL} Low-level output voltage	V _{IH} = 1.9 V, R _L = 3 kΩ	V _{CC+} = 9 V, V _{CC-} = -9 V		-7‡	-6		-7	-6	V
		V _{CC+} = 13.2 V, V _{CC-} = -13.2 V		-10.5‡	-9		-10.5	-9	
I _{IH} High-level input current	V _I = 5 V				10			10	μA
I _{IL} Low-level input current	V _I = 0			-1	-1.6		-1	-1.6	mA
I _{OS(H)} Short-circuit output current at high level§	V _I = 0.8 V,	V _O = 0	-4.6	-9	-13.5	-6	-9	-12	mA
I _{OS(L)} Short-circuit output current at low level§	V _I = 1.9 V,	V _O = 0	4.6	9	13.5	6	9	12	mA
r _o Output resistance, power off	V _{CC+} = 0, V _O = -2 V to 2 V V _{CC-} = 0,		300			300			Ω
I _{CC+} Supply current from V _{CC+}	V _{CC+} = 9 V, No load	All inputs at 1.9 V	15		20	15		20	mA
		All inputs at 0.8 V	4.5		6	4.5		6	
	V _{CC+} = 12 V, No load	All inputs at 1.9 V	19		25	19		25	
		All inputs at 0.8 V	5.5		7	5.5		7	
	V _{CC+} = 15 V, No load, T _A = 25°C	All inputs at 1.9 V			34			34	
		All inputs at 0.8 V			12			12	
I _{CC-} Supply current from I _{CC-}	V _{CC-} = -9 V, No load	All inputs at 1.9 V	-13		-17	-13		-17	mA
		All inputs at 0.8 V			-0.5			-0.015	
	V _{CC-} = -12 V, No load	All inputs at 1.9 V	-18		-23	-18		-23	
		All inputs at 0.8 V			-0.5			-0.015	
	V _{CC-} = -15 V, No load, T _A = 25°C	All inputs at 1.9 V			-34			-34	
		All inputs at 0.8 V			-2.5			-2.5	
P _D Total power dissipation	V _{CC+} = 9 V, No load V _{CC-} = -9 V,		333			333			mW
	V _{CC+} = 12 V, No load V _{CC-} = -12 V,		576			576			

† All typical values are at T_A = 25°C.

‡ The algebraic convention, in which the less positive (more negative) limit is designated as minimum, is used in this data sheet for logic voltage levels only, e.g., if -6 V is a maximum, the typical value is a more negative voltage.

§ Not more than one output should be shorted at a time.

MC1488, SN55188, SN75188 QUADRUPLE LINE DRIVERS

SLLS094B – SEPTEMBER 1983 – REVISED MAY 1995

switching characteristics, $V_{CC\pm} = \pm 9\text{ V}$, $T_A = 25^\circ\text{C}$

PARAMETER	TEST CONDITIONS	MIN	TYP	MAX	UNIT
t_{PLH} Propagation delay time, low- to high-level output	$R_L = 3\text{ k}\Omega$, See Figure 1 $C_L = 15\text{ pF}$		220	350	ns
t_{PHL} Propagation delay time, high- to low-level output			100	175	ns
t_{TLH} Transition time, low- to high-level output [†]			55	100	ns
t_{THL} Transition time, high- to low-level output [†]			45	75	ns
t_{TLH} Transition time, low- to high-level output [‡]	$R_L = 3\text{ k}\Omega$ to $7\text{ k}\Omega$, See Figure 1 $C_L = 2500\text{ pF}$		2.5		μs
t_{THL} Transition time, high- to low-level output [‡]			3.0		μs

[†] Measured between 10% and 90% points of output waveform.

[‡] Measured between 3 V and -3 V points on the output waveform (EIA/TIA-232-E conditions).

PARAMETER MEASUREMENT INFORMATION

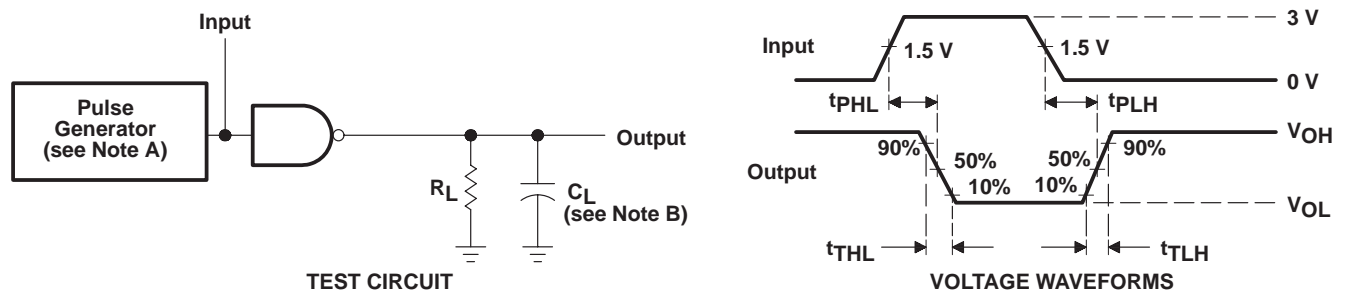

NOTES: A. The pulse generator has the following characteristics: $t_w = 0.5\ \mu\text{s}$, $\text{PRR} \leq 1\text{ MHz}$, $Z_O = 50\ \Omega$.

B. C_L includes probe and jig capacitance.

Figure 1. Test Circuit and Voltage Waveforms

MC1488, SN55188, SN75188 QUADRUPLE LINE DRIVERS

SLLS094B – SEPTEMBER 1983 – REVISED MAY 1995

TYPICAL CHARACTERISTICS†

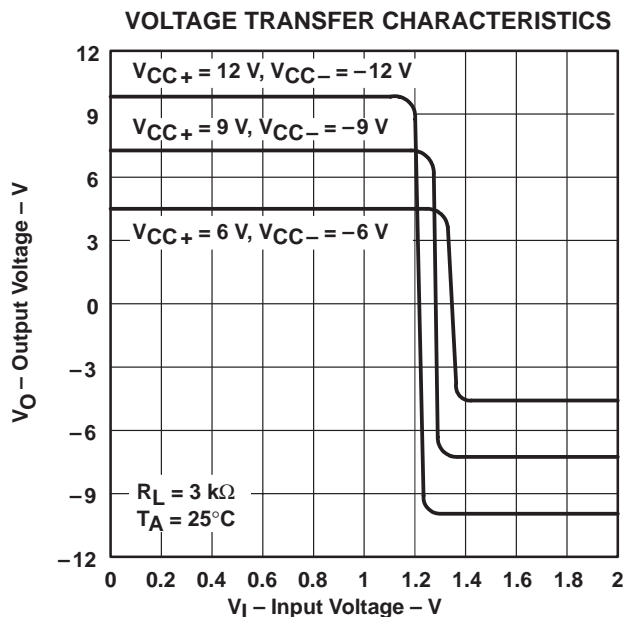

Figure 2

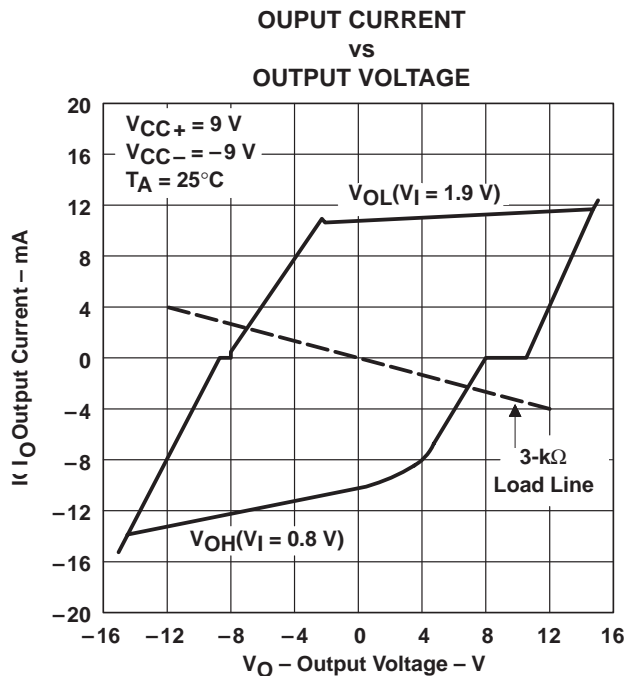

Figure 3

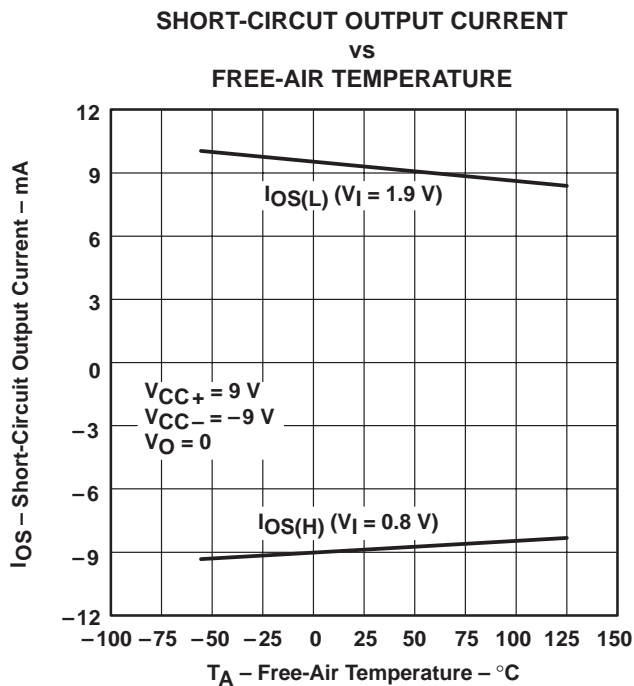

Figure 4

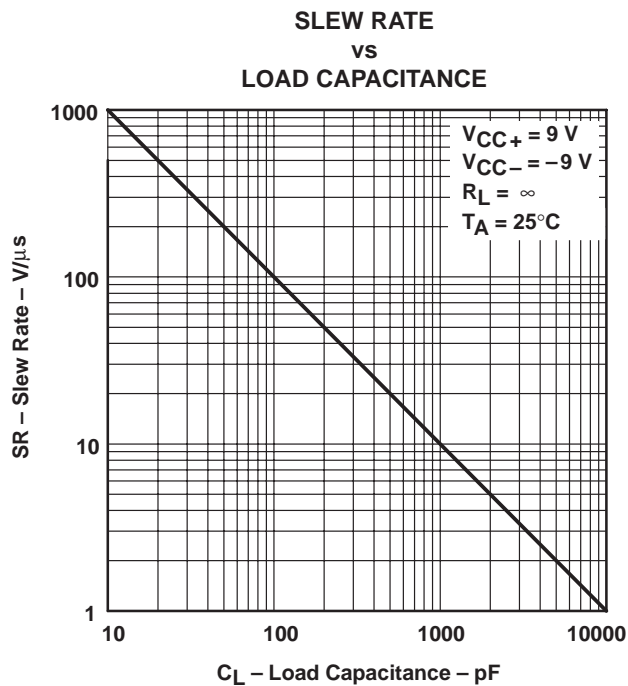

Figure 5

† Data for temperatures below 0°C and above 70°C are applicable to SN55188 circuit only.

THERMAL INFORMATION†

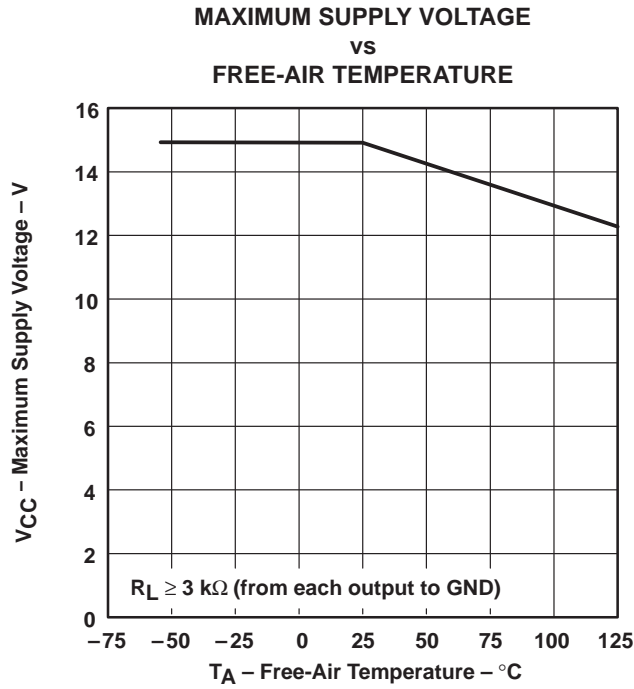

Figure 6

† Data for temperatures below 0°C and above 70°C are applicable to SN55188 circuit only.

APPLICATION INFORMATION

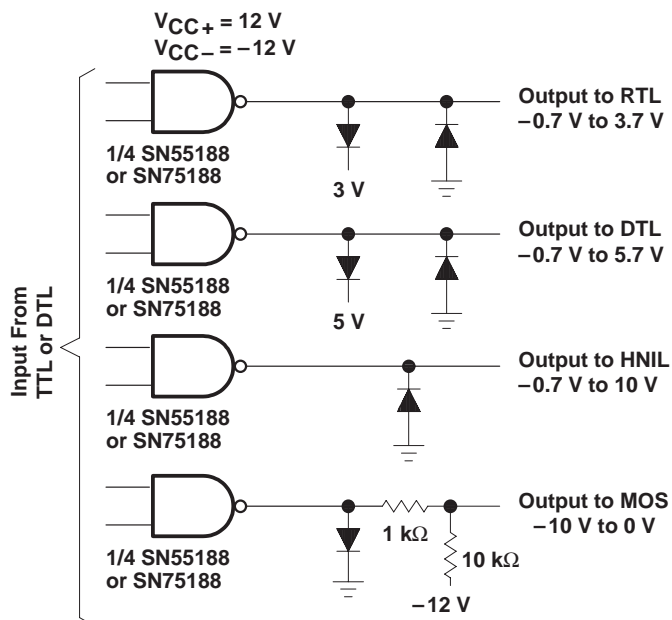
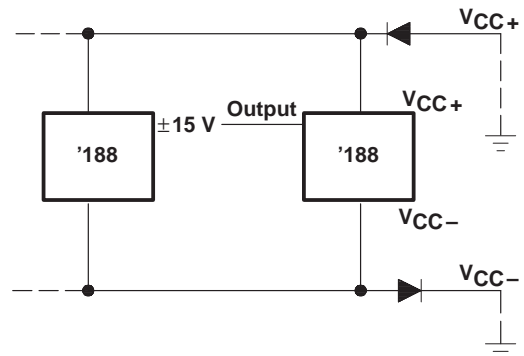

Figure 7. Logic Translator Applications



Diodes placed in series with the V_{CC+} and V_{CC-} leads will protect the SN55188/SN75188 in the fault condition in which the device outputs are shorted to $\pm 15 \text{ V}$ and the power supplies are at low voltage and provide low-impedance paths to ground.

Figure 8. Power Supply Protection to Meet Power-Off Fault Conditions of ANSI EIA/TIA-232-E

IMPORTANT NOTICE

Texas Instruments and its subsidiaries (TI) reserve the right to make changes to their products or to discontinue any product or service without notice, and advise customers to obtain the latest version of relevant information to verify, before placing orders, that information being relied on is current and complete. All products are sold subject to the terms and conditions of sale supplied at the time of order acknowledgement, including those pertaining to warranty, patent infringement, and limitation of liability.

TI warrants performance of its semiconductor products to the specifications applicable at the time of sale in accordance with TI's standard warranty. Testing and other quality control techniques are utilized to the extent TI deems necessary to support this warranty. Specific testing of all parameters of each device is not necessarily performed, except those mandated by government requirements.

CERTAIN APPLICATIONS USING SEMICONDUCTOR PRODUCTS MAY INVOLVE POTENTIAL RISKS OF DEATH, PERSONAL INJURY, OR SEVERE PROPERTY OR ENVIRONMENTAL DAMAGE ("CRITICAL APPLICATIONS"). TI SEMICONDUCTOR PRODUCTS ARE NOT DESIGNED, AUTHORIZED, OR WARRANTED TO BE SUITABLE FOR USE IN LIFE-SUPPORT DEVICES OR SYSTEMS OR OTHER CRITICAL APPLICATIONS. INCLUSION OF TI PRODUCTS IN SUCH APPLICATIONS IS UNDERSTOOD TO BE FULLY AT THE CUSTOMER'S RISK.

In order to minimize risks associated with the customer's applications, adequate design and operating safeguards must be provided by the customer to minimize inherent or procedural hazards.

TI assumes no liability for applications assistance or customer product design. TI does not warrant or represent that any license, either express or implied, is granted under any patent right, copyright, mask work right, or other intellectual property right of TI covering or relating to any combination, machine, or process in which such semiconductor products or services might be or are used. TI's publication of information regarding any third party's products or services does not constitute TI's approval, warranty or endorsement thereof.