



February 1999

LM4548 AC '97 Rev 2 Codec with Sample Rate Conversion and National 3D Sound

General Description

The LM4548 is an audio codec for PC systems which is fully PC98 compliant and performs the analog intensive functions of the AC97 Rev2 architecture. Using 18-bit Sigma-Delta A/D's and D/A's, the LM4548 provides 90dB of Dynamic Range.

The LM4548 was designed specifically to provide a high quality audio path and provide all analog functionality in a PC audio system. It features full duplex stereo A/D's and D/A's and an analog mixer with 4 stereo and 3 mono inputs, each of which has separate gain, attenuation and mute control. The LM4548 also provides the additional True Line-Level output and National's 3D Sound stereo enhancement.

The LM4548 supports variable sample rate conversion as defined in the AC97 Rev2 specification. The sample rate for the A/D and D/A can be programmed separately to convert any rate between 4kHz - 48kHz with a resolution of 1Hz. The AC97 architecture separates the analog and digital functions of the PC audio system allowing both for system design flexibility and increased performance.

Key Specifications

- Analog Mixer Dynamic Range 97dB (typ)
- D/A Dynamic Range 89dB (typ)
- A/D Dynamic Range 90dB (typ)

Features

- AC'97 Rev2 compliant
- National's 3D Sound circuitry
- High quality Sample Rate Conversion (SRC) from 4kHz to 48kHz in 1Hz increments.
- Multiple Codec Support
- True Line Level Output with volume control in addition to standard Line Out
- Advanced power management support
- Digital 3V and 5V compliant

Applications

- Desktop PC Audio Systems
- Portable PC Systems
- Mobile PC Systems

Block Diagram

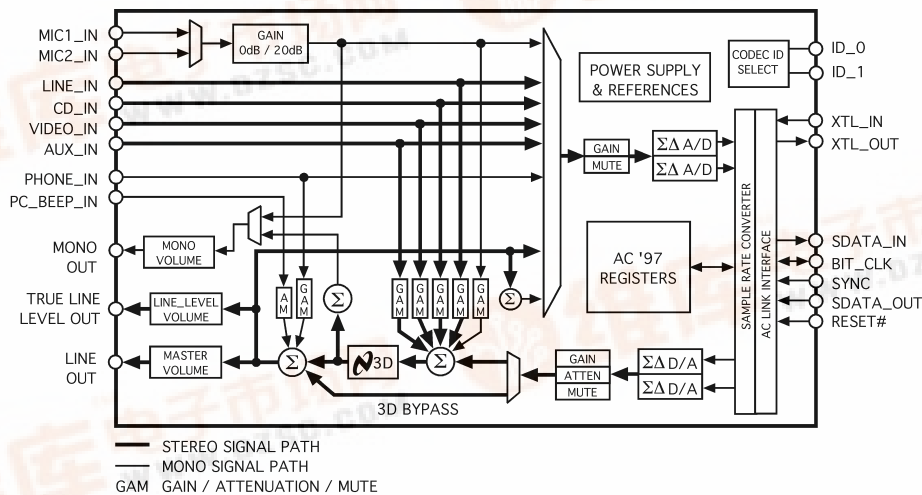

FIGURE 1. LM4548 Block Diagram

DS100987-1

LM4548 AC '97 Rev 2 Codec with Sample Rate Conversion and National 3D Sound



Absolute Maximum Ratings (Note 3)

If Military/Aerospace specified devices are required, please contact the National Semiconductor Sales Office/ Distributors for availability and specifications.

Supply Voltage	6.0V
Storage Temperature	-40°C to +150°C
Input Voltage	-0.3V to $V_{DD} + 0.3V$
ESD Susceptibility (Note 5)	2500V
pins 27, 28	1500V
pin 3	750V
ESD Susceptibility (Note 6)	200V
pin 3	100V
Junction Temperature	150°C

Soldering Information

TQFP Package	
Vapor Phase (60 sec.)	215°C
Infrared (15 sec.)	220°C

See AN-450 "Surface Mounting and their Effects on Product Reliability" for other methods of soldering surface mount devices.

θ_{JA} (typ) — VBH48A 74°C/W

Operating Ratings

Temperature Range	$-40^{\circ}\text{C} \leq T_A \leq 85^{\circ}\text{C}$
Analog Supply Range	$4.2\text{V} \leq AV_{DD} \leq 5.5\text{V}$
Digital Supply Range	$3.0\text{V} \leq DV_{DD} \leq 5.5\text{V}$

Electrical Characteristics (Notes 1, 3)

The following specifications apply for $AV_{DD} = 5V$, $DV_{DD} = 5V$, $F_s = 48\text{kHz}$, single codec configuration, unless otherwise noted. Limits apply for $T_A = 25^{\circ}\text{C}$. The reference for 0dB is $1V_{rms}$ unless otherwise specified.

Symbol	Parameter	Conditions	LM4548		Units (Limits)
			Typical (Note 7)	Limit (Note 8)	
AV_{DD}	Analog Supply Range			4.2	V (min)
				5.5	V (max)
DV_{DD}	Digital Supply Range			3.0	V (min)
				5.5	V (max)
D_{IDD}	Digital Quiescent Power Supply Current	$D_{VDD} = 5V$	43		mA
		$D_{VDD} = 3.3V$	20		mA
A_{IDD}	Analog Quiescent Power Supply Current		53		mA
I_{DSD}	Digital Shutdown Current		500		μA
I_{ASD}	Analog Shutdown Current		30		μA
V_{REF}	Reference Voltage		2.23		V
PSRR	Power Supply Rejection Ratio		40		dB
Analog Loophru Mode					
	Dynamic Range (Note 2)	CD Input to Line Output, -60dB Input THD+N, A-Weighted	97	90	dB (min)
THD	Total Harmonic Distortion	$V_O = -3\text{dB}$, $f = 1\text{kHz}$, $R_L = 10\text{k}\Omega$	0.01	0.02	% (max)
Analog Input Section					
V_{IN}	Line Input Voltage		1		V_{rms}
	Mic Input with 20dB Gain		0.1		V_{rms}
	Mic Input with 0dB Gain		1		V_{rms}
Xtalk	Crosstalk	CD Left to Right	-95		dB
Z_{IN}	Input Impedance (Note 2)		40	10	$\text{k}\Omega$ (min)
C_{IN}	Input Capacitance		15		pF
	Interchannel Gain Mismatch	CD Left to Right	0.01		dB
Record Gain Amplifier - A/D					
A_S	Step Size	0dB to 22.5dB	1.5		dB
Mixer Section					
A_S	Step Size	+12dB to -34.5dB	1.5		dB
A_M	Mute Attenuation		86		dB
Analog to Digital Converters					
	Resolution		18		Bits

Electrical Characteristics (Notes 1, 3) (Continued)

The following specifications apply for $AV_{DD} = 5V$, $DV_{DD} = 5V$, $F_s = 48kHz$, single codec configuration, unless otherwise noted. Limits apply for $T_A = 25^\circ C$. The reference for 0dB is 1Vrms unless otherwise specified.

Symbol	Parameter	Conditions	LM4548		Units (Limits)
			Typical (Note 7)	Limit (Note 8)	
Analog to Digital Converters					
	Dynamic Range (Note 2)	-60dB Input THD+N, A-Weighted	90	86	dB (min)
	Frequency Response	-1dB Bandwidth	20		kHz
Digital to Analog Converters					
	Resolution		18		Bits
	Dynamic Range (Note 2)	-60dB Input THD+N, A-Weighted	89	85	dB (min)
THD	Total Harmonic Distortion	$V_{IN} = -3dB$, $f=1kHz$, $R_L = 10k\Omega$	0.01		%
	Frequency Response		20 - 21k		Hz
	Group Delay (Note 2)			2	mS (max)
	Out of Band Energy		-40		dB
	Stop Band Rejection		70		dB
D_T	Discrete Tones		-96		dB
True Line Level Output Volume Section					
A_S	Step Size	0dB to -46.5dB	1.5		dB
A_M	Mute Attenuation		86		dB
Digital I/O (Note 2)					
V_{IL}	Low level input voltage			0.30 x DVDD	V (max)
V_{HI}	High level input voltage			0.40 x DVDD	V (min)
V_{OH}	High level output voltage			0.50 x DVDD	V (min)
V_{OL}	Low level output voltage			0.20 x DVDD	V (max)
I_L	Input Leakage Current	AC Link inputs		± 10	μA
I_L	Tri state Leakage Current	High impedance AC Link outputs		± 10	μA
I_{DR}	Output drive current	AC Link outputs	5		mA
Digital Timing Specifications (Note 2)					
F_{BC}	BIT_CLK frequency		12.288		MHz
T_{BCP}	BIT_CLK period		81.4		nS
T_{CH}	BIT_CLK high	Variation of BIT_CLK period from 50% duty cycle		± 20	% (max)
F_{SYNC}	SYNC frequency		48		kHz
T_{SP}	SYNC period		20.8		μS
T_{SH}	SYNC high pulse width		1.3		μS
T_{SL}	SYNC low pulse width		19.5		μS
T_{SETUP}	Setup Time	SDATA_IN, SDATA_OUT to falling edge of BIT_CLK		15	nS (min)
T_{HOLD}	Hold Time	Hold time of SDATA_IN, SDATA_OUT from falling edge of BIT_CLK		5	nS (min)
T_{RISE}	Rise Time	BIT_CLK, SYNC, SDATA_IN or SDATA_OUT		6	nS (max)
T_{FALL}	Fall Time	BIT_CLK, SYNC, SDATA_IN or SDATA_OUT		6	nS (max)
T_{RST_LOW}	RESET# active low pulse width	For cold reset		1.0	μS (min)
$T_{RST2CLK}$	RESET# inactive to BIT_CLK start up	For cold reset		162.8	nS (min)

Electrical Characteristics (Notes 1, 3) (Continued)

The following specifications apply for $AV_{DD} = 5V$, $DV_{DD} = 5V$, $F_s = 48kHz$, single codec configuration, unless otherwise noted. Limits apply for $T_A = 25^\circ C$. The reference for 0dB is 1Vrms unless otherwise specified.

Symbol	Parameter	Conditions	LM4548		Units (Limits)
			Typical (Note 7)	Limit (Note 8)	
Digital Timing Specifications (Note 2)					
T_{SH}	SYNC active high pulse width	For warm reset	1.3		μS
$T_{SYNC2CLK}$	SYNC inactive to BIT_CLK start up	For warm reset		162.8	nS (min)
T_{SU2RST}	Setup to trailing edge of RESET#	For ATE Test Mode		15	nS (min)
T_{RST2HZ}	Rising edge of RESET# to Hi-Z	For ATE Test Mode		25	nS (max)

Note 1: All voltages are measured with respect to the ground pin, unless otherwise specified.

Note 2: These specifications are guaranteed by design and characterization; they are not production tested.

Note 3: *Absolute Maximum Ratings* indicate limits beyond which damage to the device may occur. *Operating Ratings* indicate conditions for which the device is functional, but do not guarantee specific performance limits. *Electrical Characteristics* state DC and AC electrical specifications under particular test conditions which guarantee specific performance limits. This assumes that the device is within the Operating Ratings. Specifications are not guaranteed for parameters where no limit is given, however, the typical value is a good indication of device performance.

Note 4: The maximum power dissipation must be derated at elevated temperatures and is dictated by T_{JMAX} , θ_{JA} , and the ambient temperature T_A . The maximum allowable power dissipation is $P_{DMAX} = (T_{JMAX} - T_A) / \theta_{JA}$ or the number given in Absolute Maximum Ratings, whichever is lower. For the LM4548, $T_{JMAX} = 150^\circ C$. The typical junction-to-ambient thermal resistance is $74^\circ C/W$ for package number VBH48A.

Note 5: Human body model, 100 pF discharged through a 1.5 k Ω resistor.

Note 6: Machine Model, 220 pF–240 pF discharged through all pins.

Note 7: Typicals are measured at $25^\circ C$ and represent the parametric norm.

Note 8: Limits are guaranteed to National's AOQL (Average Outgoing Quality Level).

Timing Diagrams

Clocks

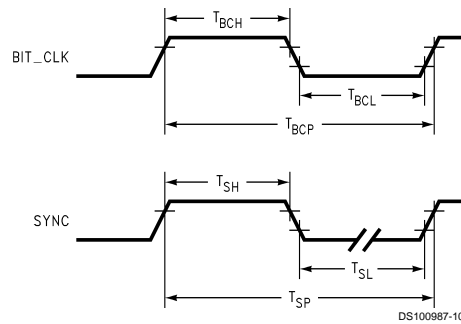

Data Setup and Hold

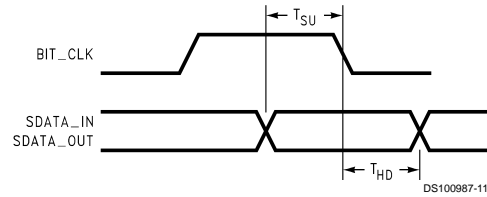

Digital Rise and Fall

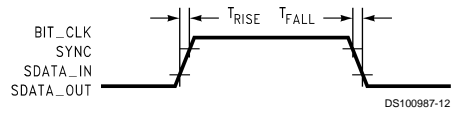

Cold Reset

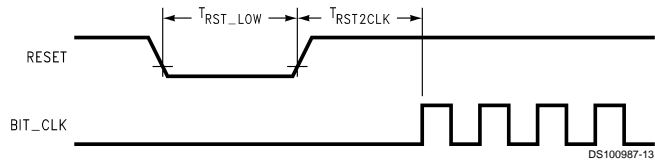

Warm Reset

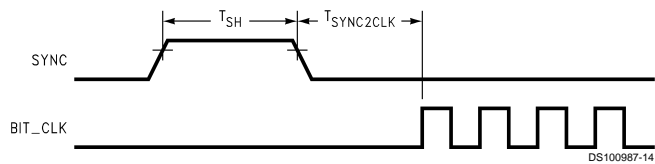

Typical Application

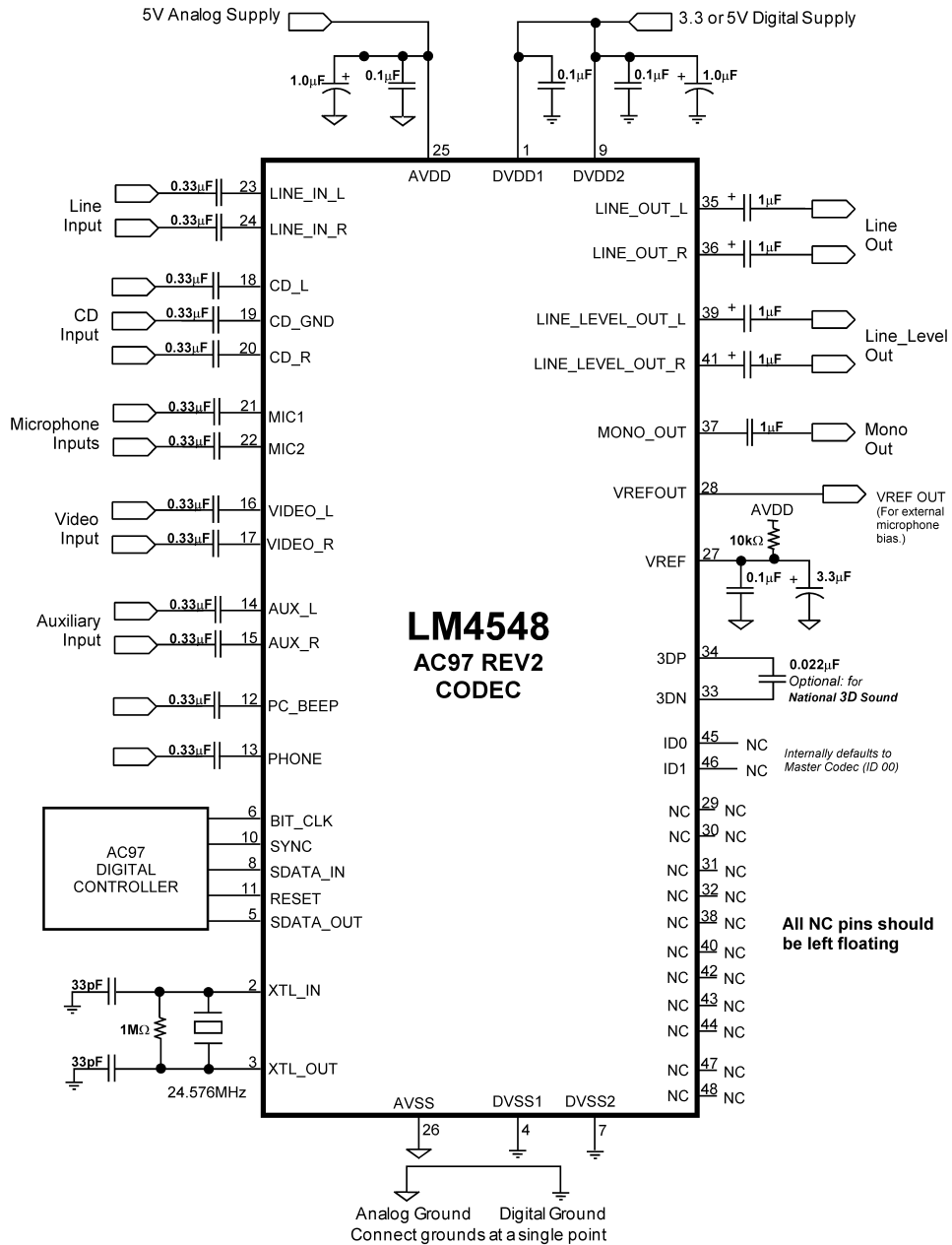
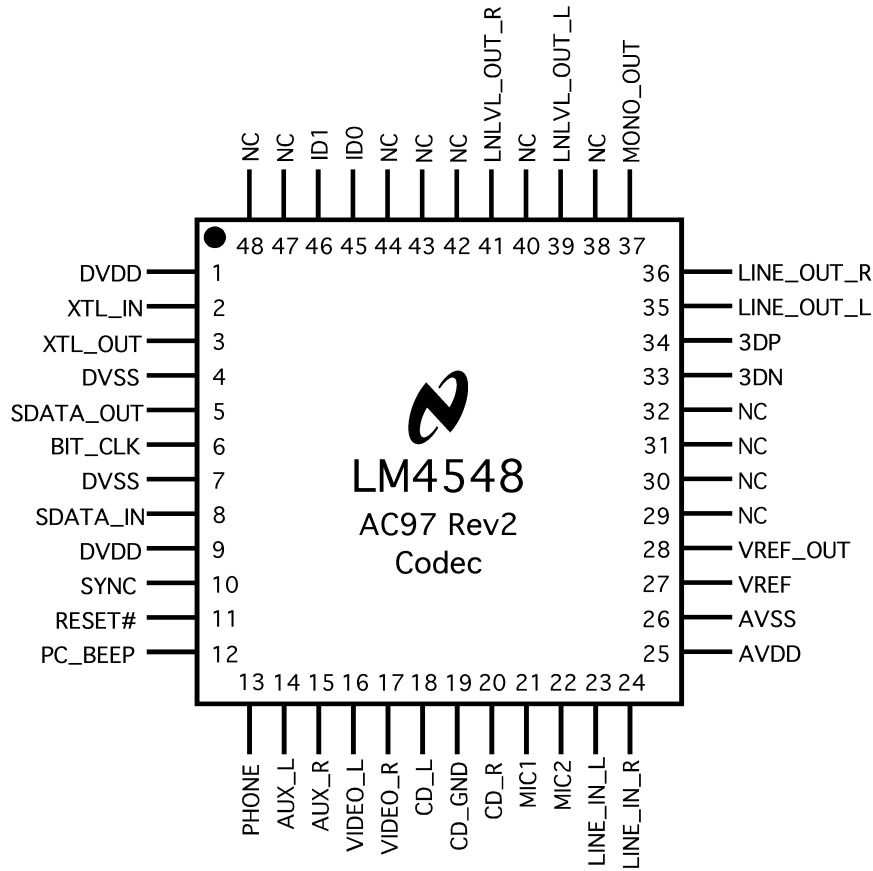

FIGURE 2. LM4548 Typical Application Circuit

DS100987-3

Connection Diagram



DS100987-2

Top View
Order Number LM4548VH
See NS Package Number VBH48A

Pin Description

Analog I/O

Name	Pin	I / O	Functional Description
PC_BEEP	12	I	This is a mono input which gets summed into both the stereo line out and the true line level out after the National 3D Sound block. The PC_BEEP level can be adjusted from 0dB to -45dB in 3dB steps, or muted, via register 0Ah.
PHONE	13	I	This is a mono input which gets summed into both the stereo line out and the true line level out after the National 3D Sound block. The PHONE level can be adjusted from +12dB to -34.5dB in 1.5dB steps as well as muted via register 0Ch.
AUX_L	14	I	This line level input can be routed through the Input Mux and recorded by the left ADC. In addition, this analog input gets summed into the left output stream. The amount of AUX_L signal mixed in the left output stream can be adjusted from +12dB to -34.5dB in 1.5dB steps as well as muted via register 16h.

Pin Description (Continued)

Analog I/O (Continued)

Name	Pin	I / O	Functional Description
AUX_R	15	I	This line level input can be routed through the Input Mux and recorded by the right ADC. In addition, this analog input gets summed into the right output stream. The amount of AUX_R signal mixed in the right output stream can be adjusted from +12dB to -34.5dB in 1.5dB steps as well as muted via register 16h.
VIDEO_L	16	I	This line level input can be routed through the Input Mux and recorded by the left ADC. In addition, this analog input gets summed into the left output stream. The amount of VIDEO_L signal mixed in the left output stream can be adjusted from +12dB to -34.5dB in 1.5dB steps as well as muted via register 14h.
VIDEO_R	17	I	This line level input can be routed through the Input Mux and recorded by the right ADC. In addition, this analog input gets summed into the right output stream. The amount of VIDEO_R signal mixed in the right output stream can be adjusted from +12dB to -34.5dB in 1.5dB steps as well as muted via register 14h.
CD_L	18	I	This line level input can be routed through the Input Mux and recorded by the left ADC. In addition, this analog input gets summed into the left output stream. The amount of CD_L signal mixed in the left output stream can be adjusted from +12dB to -34.5dB in 1.5dB steps as well as muted via register 12h.
CD_GND	19	I	This input can be used to reject common mode signals on the CD_L and CD_R inputs. CD_GND is an AC ground point and not a DC ground point. This input must be AC-coupled to the source signal's ground.
CD_R	20	I	This line level input can be routed through the Input Mux and recorded by the right ADC. In addition, this analog input gets summed into the right output stream. The amount of CD_R signal mixed in the right output stream can be adjusted from +12dB to -34.5dB in 1.5dB steps as well as muted via register 12h.
MIC1	21	I	Either MIC1 or MIC2 can be selected via software and routed through the Input Mux for recording. The 20dB boost circuit is enabled/disabled via register 0Eh. Also, the amount of mic signal mixed in the output stream can be adjusted from +12dB to -34.5dB in 1.5dB steps as well as muted via register 0Eh.
MIC2	22	I	Either MIC1 or MIC2 can be selected via software and routed through the Input Mux for recording. The 20dB boost circuit is enabled/disabled via register 0Eh. Also, the amount of mic signal mixed in the output stream can be adjusted from +12dB to -34.5dB in 1.5dB steps as well as muted via register 0Eh.
LINE_IN_L	23	I	This line level input can be routed through the Input Mux and recorded by the left ADC. In addition, this analog input gets summed into the left output stream. The amount of LINE_IN_L signal mixed in the left output stream can be adjusted from +12dB to -34.5dB in 1.5dB steps as well as muted via register 10h.
LINE_IN_R	24	I	This line level input can be routed through the Input Mux and recorded by the right ADC. In addition, this analog input gets summed into the right output stream. The amount of LINE_IN_R signal mixed in the right output stream can be adjusted from +12dB to -34.5dB in 1.5dB steps as well as muted via register 10h.
LINE_OUT_L	35	O	This is a post-mixed output for the left audio channel. The level of this output can be adjusted from 0dB to -45dB in 1.5dB steps as well as muted via register 02h.
LINE_OUT_R	36	O	This is a post-mixed output for the right audio channel. The level of this output can be adjusted from 0dB to -45dB in 1.5dB steps as well as muted via register 02h.
MONO_OUT	37	O	This line level output is either the post-mixed output or the mic input. The level of this output can be adjusted from 0dB to -45dB in 1.5dB steps as well as muted via register 06h.
LNLVL_OUT_L	39	O	This is a post-mixed output for the left audio channel. The level of this output can be adjusted from 0dB to -45dB in 1.5dB steps as well as muted via register 04h.
LNLVL_OUT_R	41	O	This is a post-mixed output for the right audio channel. The level of this output can be adjusted from 0dB to -45dB in 1.5dB steps as well as muted via register 04h.

Pin Description (Continued)

Digital I/O and Clocking

Name	Pin	I / O	Functional Description
XTL_IN	2	I	24.576 MHz crystal input. Use a fundamental-mode type crystal. When operating from a crystal, a 1M Ω resistor must be connected across pins 2 and 3.
XTL_OUT	3	O	24.576 MHz crystal output. When operating from a crystal, a 1M Ω resistor must be connected across pins 2 and 3.
SDATA_OUT	5	I	This data stream contains both control data and DAC audio data. This input is sampled by the LM4548 on the falling edge of BIT_CLK.
BIT_CLK	6	I/O	OUTPUT when in Primary Codec Mode: This pin outputs a 12.288 MHz clock which is derived (internally divided by two) from the 24.576MHz crystal input (XTL_IN). INPUT when in Secondary Codec Mode (Multiple Codec configurations only): 12.288MHz clock is to be supplied from an external source, such as from the BIT_CLK of a Primary Codec.
SDATA_IN	8	O	This data stream contains both control data and ADC audio data. This output is clocked out by the LM4548 on the rising edge of BIT_CLK.
SYNC	10	I	48kHz sync pulse which signifies the beginning of both the SDATA_IN and SDATA_OUT serial streams. SYNC must be synchronous to BIT_CLK.
RESET#	11	I	This active low signal causes a hardware reset which returns the control registers to their default conditions.
ID0	45	I	ID0 and ID1 set the codec address for multiple codec use where ID0 is the LSB. Connect these pins to DVdd or GND as required. If these pins are not connected (NC), they default to Master Codec setting (same as connecting both pins to GND). These pins are of the same polarity as their internal ID0, ID1 registers. If pin 45 is connected to GND, then ID0 will be set to "0" internally. Connection to DVdd corresponds to a "1" internally.
ID1	46	I	ID0 and ID1 set the codec address for multiple codec use where ID1 is the MSB. Connect these pins to DVdd or GND as required. If these pins are not connected (NC), they default to Master Codec setting (same as connecting both pins to GND). These pins are of the same polarity as their internal ID0, ID1 registers. If pin46 is connected to GND, then ID1 will be set to "0" internally. Connection to DVdd corresponds to a "1" internally.

Power Supplies and References

Name	Pin	I / O	Functional Description
AVDD	25	I	Analog supply.
AVSS	26	I	Analog ground.
DVDD	1,9	I	Digital supply.
DVSS	4,7	I	Digital ground.
VREF	27	O	Nominal 2.2V reference output. Not intended to sink or source current. Bypassing of this pin should be done with short traces to maximize performance.
VREFOUT	28	O	Nominal 2.2V reference output. Can source up to 5mA of current and can be used to bias a microphone.
AFILT1	29	O	This pin is not used and should be left open (NC). However, a capacitor to ground on this pin is permitted - it will not affect performance.
AFILT2	30	O	This pin is not used and should be left open (NC). However, a capacitor to ground on this pin is permitted - it will not affect performance.
3DP, 3DN	33,34	O	These pins are used to complete the National 3D Sound circuit. Connect a 0.022 μ F capacitor between pins 3DP and 3DN. The National 3D Sound can be turned on and off via bit D13 in control register 20h. This is a fixed-depth type stereo enhance circuit, thus writing to register 22h has no effect. If National 3D Sound is not needed, then these pins should be left as no connect (NC).

Typical Performance Characteristics

ADC Noise Floor

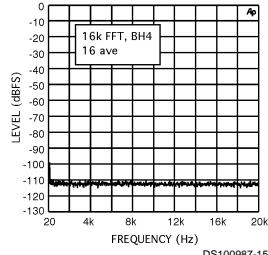

DAC Noise Floor

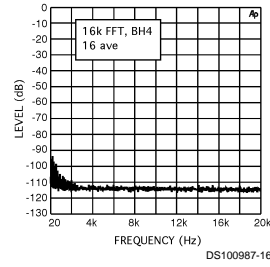

Analog Loopthru Noise Floor

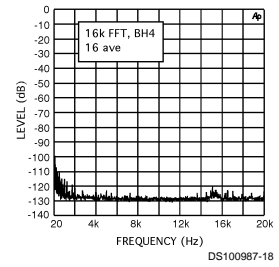

ADC Frequency Response

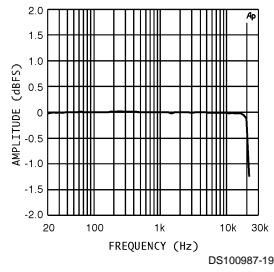

DAC Frequency Response

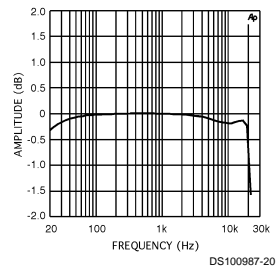

True Line Level Out Noise Floor (Analog Loopthrough)

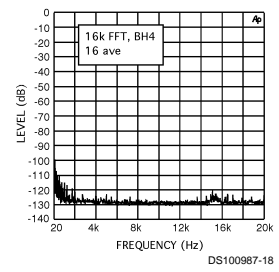

LM4548 Register Map

REG	Name	D15	D14	D13	D12	D11	D10	D9	D8	D7	D6	D5	D4	D3	D2	D1	D0	Default
00h	Reset	X	0	0	1	1	1	0	1	0	1	0	1	0	0	0	0	0d50h
02h	Master Volume	Mute	X	ML4	ML3	ML2	ML2	ML1	ML0	X	X	X	MR4	MR3	MR2	MR1	MR0	8008h
04h	True Line Level Out Volume	Mute	X	ML4	ML3	ML2	ML2	ML1	ML0	X	X	X	MR4	MR3	MR2	MR1	MR0	8000h
06h	Master Volume Mono	Mute	X	X	X	X	X	X	X	X	X	X	MM4	MM3	MM2	MM1	MM0	8000h
08h	Reserved	X	X	X	X	X	X	X	X	X	X	X	X	X	X	X	X	0000h
0Ah	PC_BEEP Volume	Mute	X	X	X	X	X	X	X	X	X	X	PV3	PV2	PV1	PV0	X	0000h
0Ch	Phone Volume	Mute	X	X	X	X	X	X	X	X	X	X	GN4	GN3	GN2	GN1	GN0	8008h
0Eh	Mic Volume	Mute	X	X	X	X	X	X	X	X	20dB	X	GN4	GN3	GN2	GN1	GN0	8008h
10h	Line In Volume	Mute	X	GL4	GL3	GL2	GL2	GL1	GL0	X	X	X	GR4	GR3	GR2	GR1	GR0	8808h
12h	CD Volume	Mute	X	GL4	GL3	GL2	GL2	GL1	GL0	X	X	X	GR4	GR3	GR2	GR1	GR0	8808h
14h	Video Volume	Mute	X	GL4	GL3	GL2	GL2	GL1	GL0	X	X	X	GR4	GR3	GR2	GR1	GR0	8808h
16h	Aux Volume	Mute	X	GL4	GL3	GL2	GL2	GL1	GL0	X	X	X	GR4	GR3	GR2	GR1	GR0	8808h
18h	PCM Out Vol	Mute	X	GL4	GL3	GL2	GL2	GL1	GL0	X	X	X	GR4	GR3	GR2	GR1	GR0	8808h
1Ah	Record Select	X	X	X	X	SL2	SL1	SL0	SL0	X	X	X	X	X	SR2	SR1	SR0	0000h
1Ch	Record Gain	Mute	X	X	GL3	GL2	GL1	GL0	GL0	X	X	X	GR3	GR2	GR1	GR0	GR0	8000h
1Eh	Reserved	X	X	X	X	X	X	X	X	X	X	X	X	X	X	X	X	0000h
20h	General Purpose	POP	X	3D	X	X	X	MIX	MS	LPBK	X	X	X	X	X	X	X	0000h
22h	3D Control (3D is fixed depth)	X	X	X	X	X	X	X	X	X	X	X	X	X	X	X	X	0000h
24h	Reserved	X	X	X	X	X	X	X	X	X	X	X	X	X	X	X	X	0000h
26h	Powerdown Ctrl/Stat	X	PR6	PR5	PR4	PR3	PR2	PR1	PR0	X	X	X	X	REF	ANL	DAC	ADC	na
28h	Extended Audio ID	ID1	ID0	X	X	X	X	X	0	0	0	X	X	0	X	0	1	X001h
2Ah	Extended Audio Status/Control	X	X	X	X	X	X	X	X	X	X	X	X	X	X	X	VRA	XXX0h
2Ch	PCM Front DAC Rate	SR15	SR14	SR13	SR12	SR11	SR10	SR9	SR8	SR7	SR6	SR5	SR4	SR3	SR2	SR1	SR0	BB80h
32h	PCM ADC Rate	SR15	SR14	SR13	SR12	SR11	SR10	SR9	SR8	SR7	SR6	SR5	SR4	SR3	SR2	SR1	SR0	BB80h
5Ah	Vendor Reserved	-	-	-	-	-	-	-	-	-	-	-	-	-	-	-	-	-
7Ah	Vendor Reserved	-	-	-	-	-	-	-	-	-	-	-	-	-	-	-	-	-
7Ch	Vendor ID1	0	1	0	0	1	1	1	0	0	1	0	1	0	0	1	1	4E53h
7Eh	Vendor ID2	0	1	0	0	0	0	1	1	0	0	0	0	0	0	0	0	4300h

Application Information

AC Link Serial Interface Protocol

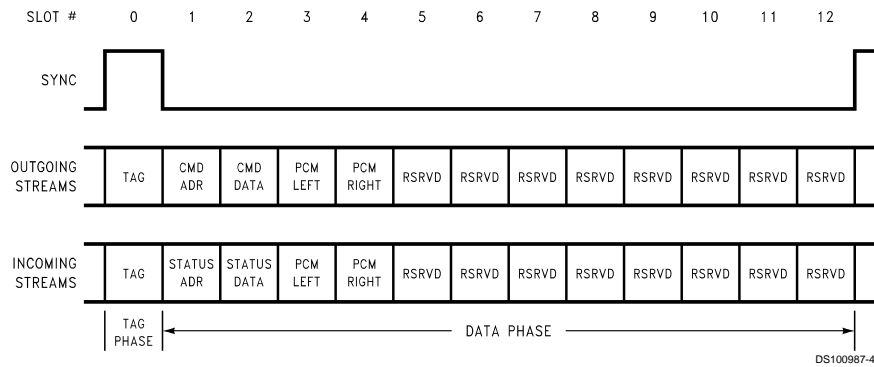

FIGURE 3. AC '97 Bidirectional Audio Frame

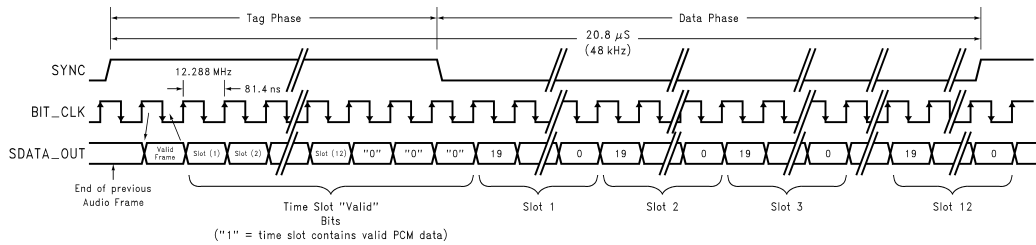

FIGURE 4. AC Link Audio Output Frame

AC Link Output Frame: SDATA_OUT (output from controller, input to LM4548)

The audio output frame (output from AC '97 Controller) contains control and PCM data targeted for the LM4548 control registers and stereo DAC. The Tag slot, slot 0, contains 16 bits that tell the AC Link interface circuitry on the LM4548 the validity of the following data slots.

A new audio output frame is signaled with a low to high transition of SYNC. SYNC is synchronous to the rising edge of BIT_CLK. On the next rising edge of BIT_CLK, the AC '97 Controller drives SDATA_OUT with the first bit of slot 0. The LM4548 samples SDATA_OUT on the falling edge of BIT_CLK. The AC '97 Controller will continue outputting the SDATA_OUT stream on each successive rising edge of BIT_CLK.

SDATA_OUT Slot 0: Tag Phase

The first bit of slot 0 is designated the "Valid Frame" bit. If this bit is 1, it indicates that the current data frame contains at least one slot of valid data and the LM4548 will further sample the next four bits to determine which frames do in fact have valid data. Valid slots are signified by a 1 in their respective slot bit position.

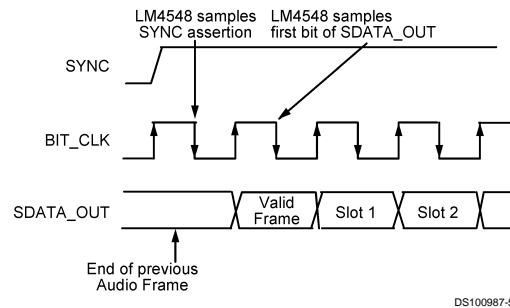

FIGURE 5. Start of Audio Output Frame

Bit	Description	Comment
15	Valid Frame	1 = This frame has valid data.
14	Control register address	1 = Control Address is valid.
13	Control register data	1 = Control Data is valid.
12	Left Playback PCM Data	1 = Left PCM Data is valid.

Application Information (Continued)

Bit	Description	Comment
11	Right Playback PCM Data	1 = Right PCM Data is valid.

SDATA_OUT Slot 1: Control Address

Slot 1 is used both to write to the LM4548 registers as well as read back a register's current value. The MSB of Slot 1 (bit 19) signifies whether the current control operation is a read or a write. Bits 18 through 12 are used to specify the register address of the read or write operation. The least significant twelve bits are reserved and should be stuffed with zeros by the AC'97 controller.

Bits	Description	Comment
19	Read/Write	0 = Read, 1 = Write
18:12	Control Register	Identifies the Control Register
11:0	Reserved	Set to "0"

SDATA_OUT Slot 2: Control Data

Slot 2 is used to transmit 16 bit control data to the LM4548 in the event that the current operation is a write operation. The least significant four bits should be stuffed with zeros by the AC '97 controller. If the current operation is a register read, the entire slot, bits 19 through 0 should be stuffed with zeros.

Bits	Description	Comment
19:4	Control Register Write Data	Set bits to "0" if read operation
3:0	Reserved	Set to "0"

SDATA_OUT Slot 3: PCM Playback Left Channel

Slot 3 is a 20 bit field used to transmit data intended for the left DAC on the LM4548. Any unused bits should be padded with zeros. The LM4548 DAC's have 18 bit resolution and thus will use the first 18 bits of the 20 bit PCM stream.

Bits	Description	Comment
19:0	PCM Audio Data for Left DAC	Set unused bits to "0"

SDATA_OUT Slot 4: PCM Playback Right Channel

Slot 4 is a 20 bit field used to transmit data intended for the right DAC on the LM4548. Any unused bits should be padded with zeros. The LM4548 DAC's have 18 bit resolution and thus will use the first 18 bits of the 20 bit PCM stream.

Bits	Description	Comment
19:0	PCM Audio Data for Right DAC	Set unused bits to "0"

SDATA_OUT Slots 5-12: Reserved

Set these SDATA_OUT slots to "0" as they are not currently implemented and are reserved for future use.

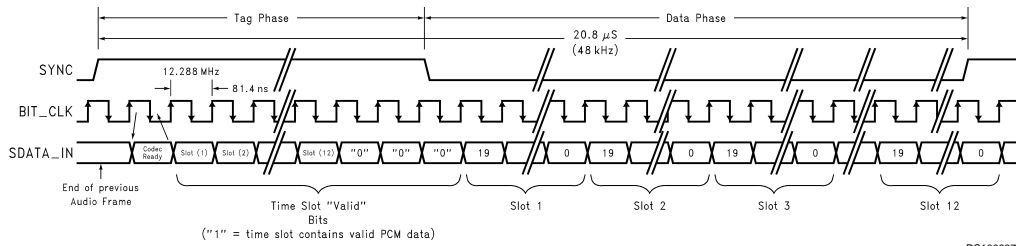

FIGURE 6. AC Link Audio Input Frame

AC Link Input Frame: SDATA_IN (input to controller, output from LM4548)

The audio input frame (input to the AC '97 Digital Controller) contains status and PCM data from the LM4548 control registers and stereo ADC. The Tag slot, slot 0, contains 16 bits that tell the AC '97 Digital Controller whether the LM4548 is ready and the validity of data from certain device subsections.

A new audio input frame is signaled with a low to high transition of SYNC. SYNC is synchronous to the rising edge of BIT_CLK. On the next rising edge of BIT_CLK, the LM4548 drives SDATA_IN with the first bit of slot 0. The Digital Controller samples SDATA_IN on the falling edge of BIT_CLK. The LM4548 will continue outputting the SDATA_IN stream on each successive rising edge of BIT_CLK. The LM4548 outputs data MSB first, in a MSB justified format. All reserved bits and slots are stuffed with "0" 's by the LM4548.

SDATA_IN Slot 0: Codec Status Bits

The first bit of SDATA_IN Slot 0 (bit 15) indicates when the Codec is ready. The digital controller must probe further to see which other subsections are ready.

Application Information (Continued)

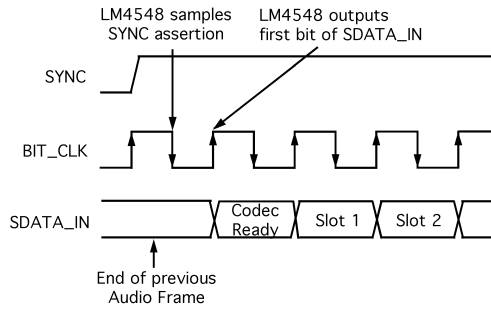

DS100987-7

FIGURE 7. Start of Audio Input Frame

Bit	Description	Comment
15	Codec Ready Bit	0=Not Ready, 1=Ready
14	Slot 1 data valid	Status Address is valid
13	Slot 2 data valid	Status Data is valid
12	Slot 3 data valid	Left Audio PCM Data is valid
11	Slot 4 data valid	Right Audio PCM Data is valid

SDATA_IN Slot 1: Status Address / Slot Request Bits

This slot echoes the control register which a read was requested on. The address echoed was initiated by a read request in the previous SDATA_OUT frame, slot 1. Bits 11 and 10 are slot request bits that support Sample Rate Conversion (SRC) functionality. If bit 11 is set to 0, then the controller should respond with a valid PCM left sample in slot 3 of the next frame. If bit 10 is set to 0, then the controller should respond with a valid PCM right sample in slot 4 of the next frame. If bits 11 or 10 are set to 1, the controller should not send data in the next frame. Bits 9 through 2 are unused. Bits 1 and 0 are reserved and should be set to 0.

Bits	Description	Comment
19	Reserved	Stuffed with "0"
18:12	Control Register Index	Echo of Control Register for which data is being returned.
11	Slot 3 Request bit (PCM left)	0 = Controller should send valid slot 3 data in the next frame, 1 = Controller should not send slot 3 data in the next frame
10	Slot 4 Request bit (PCM right)	0 = Controller should send valid slot 4 data in the next frame, 1 = Controller should not send slot 4 data in the next frame

Bits	Description	Comment
9:2	Other Slot Request bits	Unused
1,0	Reserved	Stuff with "0"

SDATA_IN Slot 2: Status Data

The slot returns the control register data. The data returned was initiated by a read request in the previous SDATA_OUT frame, slot 1.

Bits	Description	Comment
19:4	Control Register Read Data	
3:0	Reserved	Stuffed with "0" 's

SDATA_IN Slot 3: PCM Record Left Channel

This slot contains the left ADC sample data. The signal to be digitized is selected via register 1Ah and subsequently routed through the Input Mux for recording by the left ADC. This is a 20-bit slot, where the digitized 18-bit PCM data is output from the codec MSB first and the last remaining 2 bits will zeros.

Bits	Description	Comment
19:2	PCM Record Left Channel data	18 bit audio sample from left ADC
1:0	Reserved	Stuffed with "0" 's

SDATA_IN Slot 4: PCM Record Right Channel

This slot contains the right ADC sample data. The signal digitized is selected via register 1Ah and subsequently routed through the Input Mux for recording by the right ADC. This is a 20-bit slot, where the digitized 18-bit PCM data is output from the codec MSB first and the last remaining 2 bits will zeros.

Bits	Description	Comment
19:2	PCM Record Right Channel data	18 bit audio sample from right ADC
1:0	Reserved	Stuffed with "0" 's

SDATA_IN Slots 5-12: Reserved

These SDATA_IN slots are set to "0" as they are reserved for future use.

AC Link Low Power Mode

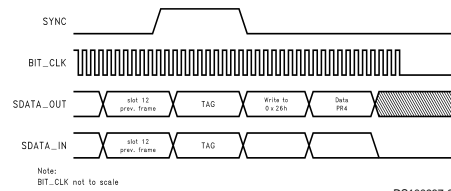

DS100987-9

FIGURE 8. AC Link Powerdown Timing

Application Information (Continued)

Register Descriptions

Reset Register (00h)

Writing any value to this register causes a register reset which changes all of the registers back to their default values. If a read is performed on this register, the LM4548 will return a value of 0D50h indicating that National 3D Sound is implemented, 18bit data is supported for both the ADC's and DAC's, and the volume control for True Line Level Out is supported.

Master Volume Registers (02h, 04h, 06h)

These registers allow the output levels from LINE_OUT, LN_LVL_OUT and MONO_OUT to be attenuated or muted. There are 6-bits of volume control, plus one mute bit. It is a 5-bit volume range, where each step is nominally 1.5dB and each output can be individually muted by either setting the most significant bit (Mx5), and/or the mute bit (D15) to "1."

Mute	Mx5:Mx0	Function
0	00 0000	0dB attenuation
0	01 1111	46.5dB attenuation
0	1X XXXX	46.5dB attenuation
1	XX XXXX	mute

Default: 8000h

PC BEEP Register (0Ah)

This register controls the level of the PC_BEEP input. The PC_BEEP can be both attenuated and muted via register 0Ah. Step size is nominally 3dB. The signal present after the attenuation and mute block is summed into both the left and right channels.

Mute	PV3:0	Function
0	0000	0dB attenuation
0	1111	45dB attenuation
1	XXXX	mute

Default: 0000h

Mixer Input Volume Registers (Index 0Ch - 18h)

These registers set the input volume levels including mute. Each volume control is 5 bit which provides from a range of +12dB gain to 34.5dB attenuation in 1.5dB steps. For stereo ports, the left and right levels can be independently set. Muting a given port is accomplished by setting the MSB to 1. Setting the MSB to 1 for stereo ports mutes both the left and right channel. Register 0Eh has an additional 20dB boost for a microphone level input. This is enabled by setting bit 6 of register 0Eh to 1.

Mute	Gx4:Gx0	Function
0	00000	+12dB gain
0	01000	0dB gain
0	11111	34.5dB attenuation
1	XXXXX	mute

Default: 8008h (mono regs.), 8808h (stereo regs.)

Record Select Register (1Ah)

This register independently controls the source for the right and left channel which will be recorded by the stereo ADC. The default value is 0000h which corresponds to Mic in.

SL2:SL0	Left Record Source
0	Mic
1	CD In (L)
2	Video In (L)
3	Aux In (L)
4	Line In (L)
5	Stereo Mix (L)
6	Mono Mix (L)
7	Phone

SR2:SR0	Right Record Source
0	Mic
1	CD In (R)
2	Video In (R)
3	Aux In (R)
4	Line In (R)
5	Stereo Mix (R)
6	Mono Mix (R)
7	Phone

Record (Input) Gain Register (1Ch)

This registers controls the Record (Input) Gain level for the stereo input selected via the Record Select Control Register (1Ah). The gain can be programmed from 0dB to +22.5dB in 1.5dB steps. The level for the left and right channel can be individually controlled. The input can also be muted by setting the MSB to 1.

Mute	Gx3:Gx0	Function
0	1111	22.5dB gain
0	0000	0dB gain
1	XXXX	mute

Default: 8000h

General Purpose Register (20h)

This register controls many miscellaneous functions implemented on the LM4548. The miscellaneous functions include POP which allows the PCM to bypass the National 3D Sound circuitry, 3D which enables or disables the National 3D Sound circuitry, MIX which selects the MONO_OUT source, MS which selects the microphone mux source and LPBK which connects the output of the stereo ADC to input of the stereo DAC. LPBK provides for a digital loopthru path when enabled.

BIT	Function
POP	PCM out path and mute, 0 = pre 3D, 1 = post 3D
3D	National 3D Sound on / off 1 = on
MIX	Mono output select 0 = Mix, 1 = Mic
MS	Mic select 0 = Mic1 1 = Mic2
LPBK	ADC/DAC loopback

Powerdown Control / Status Register (26h)

This read/write register is used to monitor subsystem readiness and also to program the LM4548 powerdown states. The lower half of this register is read only with a "1", indicating the subsection is ready. Writing to the lower 8 bits will have no effect.

Application Information (Continued)

When the AC Link "Codec Ready" indicator bit (SDATA_IN slot 0, bit 15) is a "1", it indicates that the AC Link and AC '97 registers are in a fully operational state. The AC '97 Controller must further probe the Powerdown Control / Status Register to determine exactly which subsections are ready.

BIT	Function
REF	Vref's up to nominal level
ANL	Analog mixers ready
DAC	DAC section ready to accept data
ADC	ADC section ready to transmit data

Supported powerdown modes.

BIT	Function
PRO	PCM in ADC's and Input Mux powerdown
PR1	PCM out DAC's powerdown
PR2	Analog Mixer powerdown (VREF still on)
PR3	Analog Mixer powerdown (VREF off)
PR4	Digital Interface (AC Link) powerdown (external clk off)
PR5	Internal Clk disable
PR6	not used

Extended Audio ID Register (28h)

This read only register identifies which AC97 Extended Audio features are supported. The LM4548 provides for VRA (Variable Rate Audio) and Multiple Codec support. VRA is indicated by a "1" in the LSB of register 28h. The two MSB's, ID1 and ID0, show the current codec configuration as connected via external pins 45 and 46.

Pin46 (ID1)	Pin45 (ID0)	Reg 28h ID1	Reg 28h ID0	Codec Mode
NC (not connected)	NC (not connected)	0	0	Primary
GND	GND	0	0	Primary
GND	DVdd	0	1	Secondary 1
DVdd	GND	1	0	Secondary 2
DVdd	DVdd	1	1	Secondary 3

Extended Audio Status/Control Register (2Ah)

This read/write register provides status and control of the Variable Sample Rate function. Setting the LSB of this register to "1" enables Variable Rate Audio (VRA) mode and allows DAC and ADC sample rates to be programmed via registers 2Ch and 32h.

BIT	Function
VRA	0 = VRA off (48kHz fixed), 1 = VRA on

Sample Rate Control Registers (2Ch, 32h)

These read/write registers are used to set the sample rate for the left and right channels of the DAC (2Ch) and the ADC (32h). When Variable Rate Audio is enabled via bit-0 of Register 2Ah, the sample rates can be programmed, in 1Hz increments, to be any value from 4kHz to 48kHz. Below is a list of the most common sample rates and their corresponding register values.

SR15:SR0	Sample Rate (Hz)
1F40h	8000

SR15:SR0	Sample Rate (Hz)
2B11h	11025
3E80h	16000
5622h	22050
AC44h	44100
BB80h	48000

Reserved Registers

Do not write to these registers as they are reserved.



Physical Dimensions inches (millimeters) unless otherwise noted

METRIC ONLY

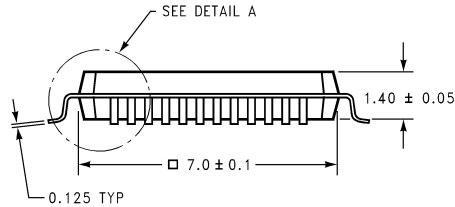
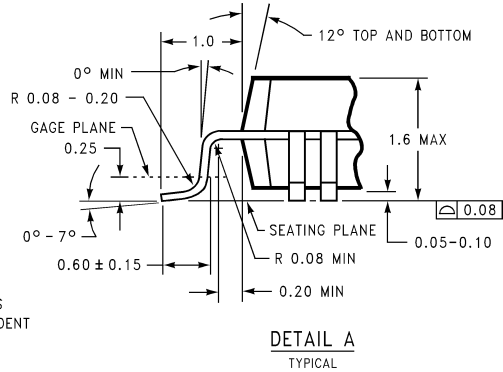
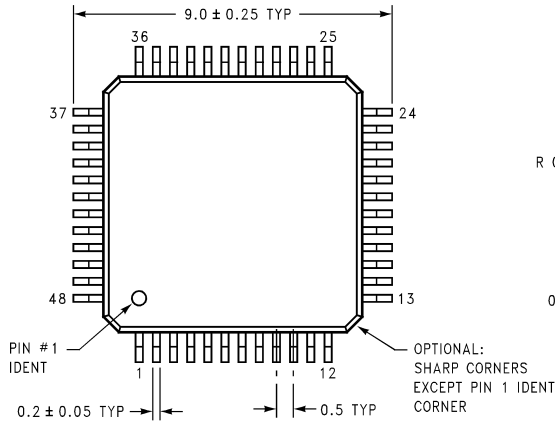

48-Lead, TQFP, 7 X 7 X 1.4mm, JEDEC (M)
Order Number LM4548VH
NS Package Number VBH48A

VBH48A (REV C)

LIFE SUPPORT POLICY

NATIONAL'S PRODUCTS ARE NOT AUTHORIZED FOR USE AS CRITICAL COMPONENTS IN LIFE SUPPORT DEVICES OR SYSTEMS WITHOUT THE EXPRESS WRITTEN APPROVAL OF THE PRESIDENT OF NATIONAL SEMICONDUCTOR CORPORATION. As used herein:

1. Life support devices or systems are devices or systems which, (a) are intended for surgical implant into the body, or (b) support or sustain life, and whose failure to perform when properly used in accordance with instructions for use provided in the labeling, can be reasonably expected to result in a significant injury to the user.
2. A critical component is any component of a life support device or system whose failure to perform can be reasonably expected to cause the failure of the life support device or system, or to affect its safety or effectiveness.



National Semiconductor Corporation
 Americas
 Tel: 1-800-272-9959
 Fax: 1-800-737-7018
 Email: support@nsc.com

www.national.com

National Semiconductor Europe
 Fax: +49 (0) 1 80-530 85 86
 Email: europe.support@nsc.com
 Deutsch Tel: +49 (0) 1 80-530 85 85
 English Tel: +49 (0) 1 80-532 78 32
 Français Tel: +49 (0) 1 80-532 93 58
 Italiano Tel: +49 (0) 1 80-534 16 80

National Semiconductor Asia Pacific Customer Response Group
 Tel: 65-2544466
 Fax: 65-2504466
 Email: sea.support@nsc.com

National Semiconductor Japan Ltd.
 Tel: 81-3-5639-7560
 Fax: 81-3-5639-7507