

---

# HA16654A, HA16664A Series

## PWM Controlled Switching Regulator

# HITACHI

---

The HA16654A and HA16664A are PWM control switching regulator ICs which drive a power MOSFET at high speed and high frequency. The standby current is limited to as small as 1.5 mA (typ). These devices incorporate totem pole circuits suited for high-speed push-pull operation at the output stage, accomplishing high-speed switching with rising time  $t_r = 80$  ns (typ) and falling time  $t_f = 40$  ns (typ) at 20 V swing.

### Functions

- Reference voltage circuit
- Triangular waveform oscillation circuit
- PWM comparator circuit
- Low-input malfunction protection circuit
- Output drive circuit
- Soft start and quick shut down

### Features

- High speed switching:  $t_r = 80$  ns,  $t_f = 40$  ns (typ) when use external driver circuit
- High frequency operation:
  - HA16654A (f = 100 kHz to 500 kHz)
  - HA16664A (f = 100 kHz to 200 kHz)
- Low power dissipation : 2 mA max in standby state
- 5 V reference voltage
- Low-input malfunction protection (High threshold voltage: 10 V Typ, Low threshold voltage: 8 V Typ)
- Adjustable dead band width
- Enlarged output pulse width control range (0 to 80%)
- Soft start and quick shut down functions
- Single output: totem pole



## HA16654A, HA16664A Series

### Ordering Information

Type No.	Operating Frequency	Package
HA16654APS	100 kHz to 500 kHz	DP-8
HA16654AFP		FP-14DA
HA16664APS	100 kHz to 200 kHz	DP-8
HA16664AFP		FP-14DA

### Pin Arrangement

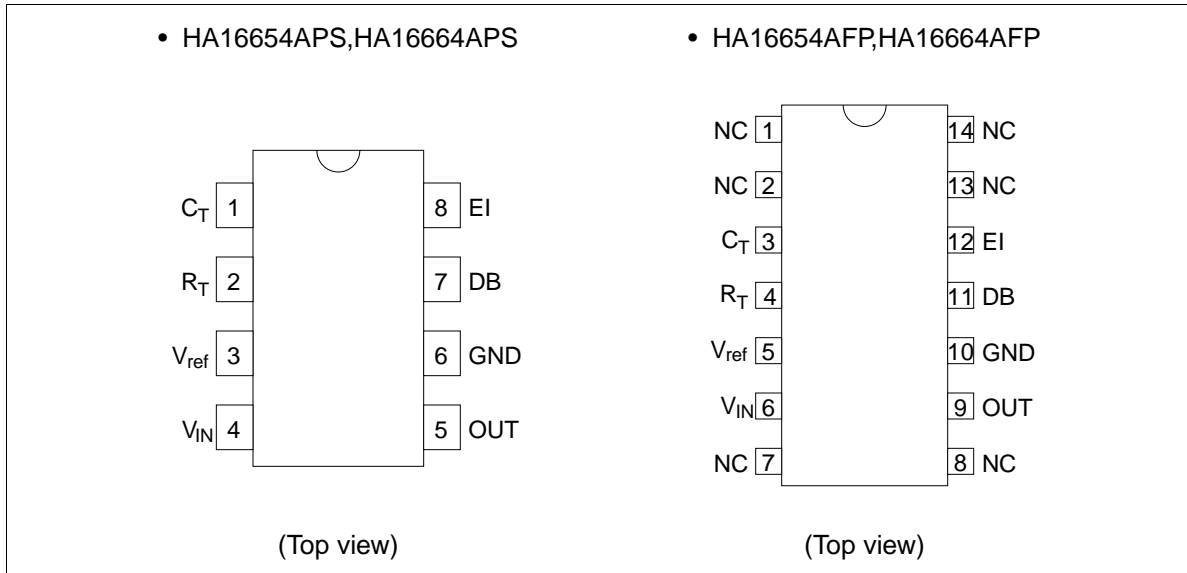

**Table 1 Pin Function**

Symbol	Pin Name
$C_T$	Timing capacitor
$R_T$	Timing resistor
$V_{ref}$	Reference voltage
$V_{IN}$	Input voltage
EI	Error input
DB	Dead band
GND	Ground
OUT	Driver output

Block Diagram

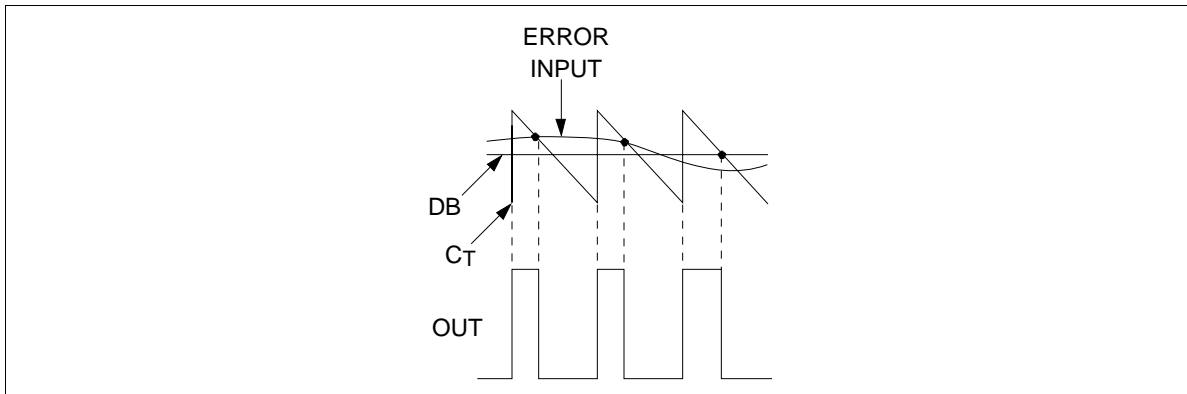
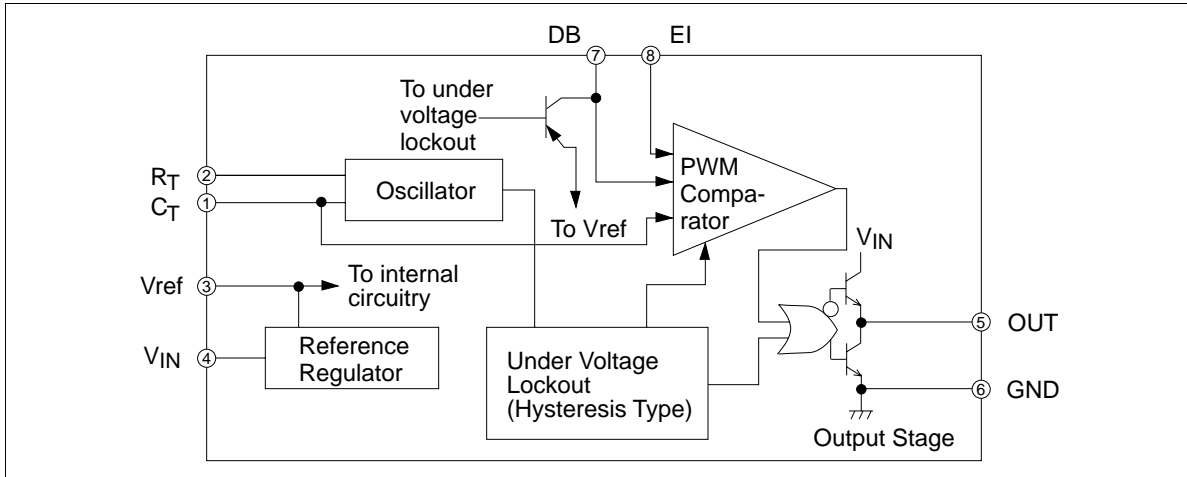

Figure 1 Waveform Timing

## HA16654A, HA16664A Series

### Absolute Maximum Ratings (Ta = 25°C)

Item	Symbol	Rating	Unit	Notes
Power supply voltage	V <sub>IN</sub>	+40	V	
Collector current (Push-pull)	I <sub>O</sub>	20	mA	
Comparator input voltage	V <sub>COM</sub>	V <sub>ref</sub> + 0.3	V	
R <sub>T</sub> input current	I <sub>RT</sub>	1	mA	
Power dissipation	P <sub>T</sub>	680	mW	1, 2
Operation temperature range	Topr	-20 to +85	°C	
Storage temperature range	Tstg	-55 to 125	°C	

Notes: 1. Ta ≤ 45°C, if Ta > 45°C, derate by 8.3 mW/°C

2. Tjmax = θj-a • Pcmx + Ta (θj-a: Thermal resistance between junction and atmosphere at set board use)

The wiring density and the material of the set board must be chosen for thermal conductance of efficacy board.

### Electrical Characteristics

HA16654APS/AFP (Ta = 25°C, V<sub>IN</sub> = 20 V, C<sub>T</sub> = 220 pF, R<sub>T</sub> = 27 kΩ at f = 500 kHz)

#### Voltage Reference

Item	Symbol	Min	Typ	Max	Unit	Test Condition
Output voltage	V <sub>ref</sub>	4.75	5.00	5.25	V	
Line regulation	Line	—	—	100	mV	V <sub>IN</sub> = 7.3 to 11 V
		—	10	25	mV	V <sub>IN</sub> = 11 to 40 V
Load regulation	Load	—	5	16	mV	I <sub>O</sub> = 0 to 10 mA
Temperature stability	V <sub>RTC</sub>	—	-26	—	ppm/°C	
Short circuit current	I <sub>OS</sub>	10	35	—	mA	V <sub>ref</sub> = 0 V

## HA16654A, HA16664A Series

### Oscillator

Item	Symbol	Min	Typ	Max	Unit	Test Condition
Maximum frequency	$f_{max}$	500	—	—	kHz	$C_T = 220 \text{ pF}$
Minimum frequency	$f_{min}$	—	—	100	kHz	$C_T = 560 \text{ pF}$
Initial accuracy	$f_{dev}$	—	—	$\pm 10$	%	
Voltage stability	$f_{av}$	—	-0.02	$\pm 1.0$	kHz/V	$V_{IN} = 11 \text{ to } 40 \text{ V}$

### PWM

Item	Symbol	Min	Typ	Max	Unit	Test Condition
Maximum duty cycle	Du	80	—	—	%	
Duty cycle accuracy	Ddev	—	$\pm 1$	$\pm 6$	%	$R_1 = 13 \text{ k}\Omega$ , $R_2 = 39 \text{ k}\Omega$
Input bias current	$I_B$	—	—	2.0	$\mu\text{A}$	$V_{E1} = 4 \text{ V}$ , $V_{DB} = 0 \text{ V}$ or $V_{E1} = 0 \text{ V}$ , $V_{DB} = 4 \text{ V}$

### Output Driver

Item	Symbol	Min	Typ	Max	Unit	Test Condition
Sink current at $V_{in}$ low	$I_{OS(Low)}$	0.6	1.5	—	mA	$V_{IN} = 6 \text{ V}$ , $V_{OUT} = 0.4 \text{ V}$
Output low level	$V_{OL}$	—	0.86	1.4	V	$I_O(\text{sink}) = 10 \text{ mA}$
Output high level	$V_{OH}$	$V_{IN} - 2.2$	—	—	V	$I_O(\text{source}) = 10 \text{ mA}$
Output rising time	$t_r$	—	80	150	ns	Figure 3
Output falling time	$t_f$	—	40	100	ns	Figure 3
High level threshold	$V_{THH}$	9	10	11	V	UVL characteristics
Low level threshold	$V_{THL}$	7.3	8	9	V	UVL characteristics
Hysteresis width	$V_{HRS}$	1.5	2.0	2.5	V	UVL characteristics

### Total Current

Item	Symbol	Min	Typ	Max	Unit	Test Condition
Standby current	$I_{CCS}$	—	1.5	2.0	mA	Figure 2
Operation current	$V_{CCL}$	5.0	9.0	13.0	mA	$R_1 = 13 \text{ k}\Omega$ , $R_2 = 29 \text{ k}\Omega$ , $V_{IN} = 20 \text{ V}$ Figure 2

## HA16654A, HA16664A Series

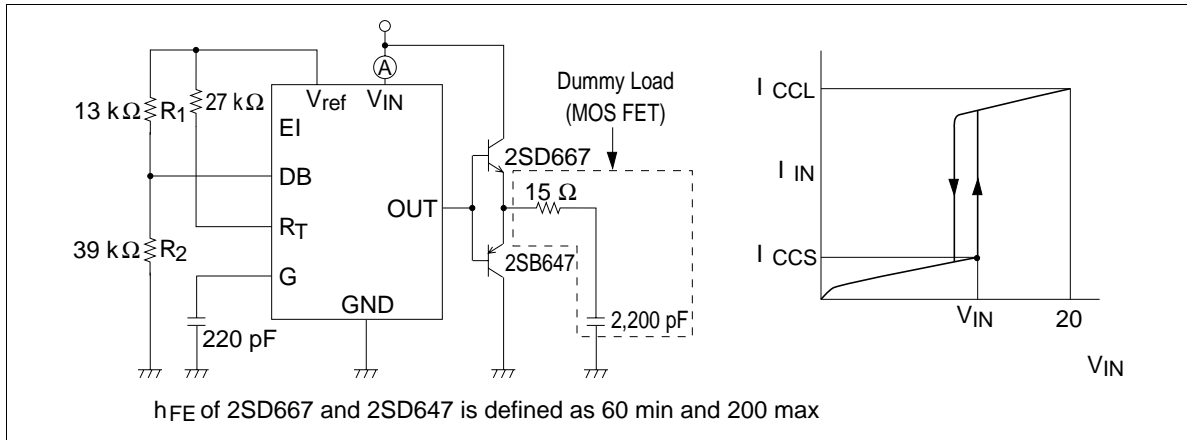

Figure 2  $I_{CCS} \cdot I_{CCL}$  Measurement Circuit

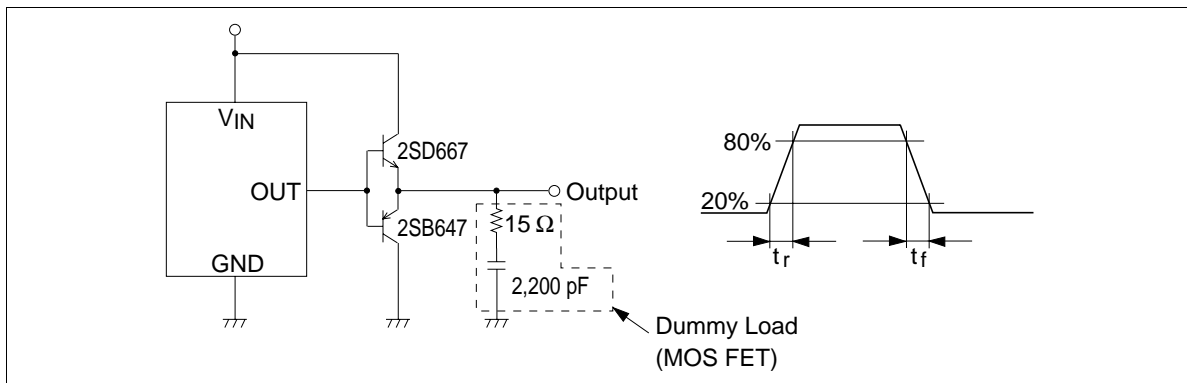

Figure 3  $t_r, t_f$  Measurement Circuit

HA16664APS/AFP ( $T_a = 25^\circ\text{C}$ ,  $V_{IN} = 20\text{ V}$ ,  $C_T = 560\text{ pF}$ ,  $R_T = 82\text{ k}\Omega$  at  $f = 100\text{ kHz}$ )

### Voltage Reference

Item	Symbol	Min	Typ	Max	Unit	Test Condition
Output voltage	V <sub>ref</sub>	4.75	5.00	5.25	V	
Line regulation	Line	—	—	100	mV	$V_{IN} = 7.3\text{ to }11\text{ V}$
		—	10	25	mV	$V_{IN} = 11\text{ to }40\text{ V}$
Load regulation	Load	—	5	16	mV	$I_O = 0\text{ to }10\text{ mA}$
Temperature stability	V <sub>RTC</sub>	—	-26	—	ppm/ $^\circ\text{C}$	
Short circuit current	I <sub>OS</sub>	10	35	—	mA	V <sub>ref</sub> = 0 V

## HA16654A, HA16664A Series

### Oscillator

Item	Symbol	Min	Typ	Max	Unit	Test Condition
Maximum frequency	$f_{\max}$	200	—	—	kHz	$C_T = 220 \text{ pF}$
Minimum frequency	$f_{\min}$	—	—	100	kHz	$C_T = 560 \text{ pF}$
Initial accuracy	$f_{\text{dev}}$	—	—	$\pm 10$	%	
Voltage stability	$f_{\text{av}}$	—	-0.02	$\pm 1.0$	kHz/V	$V_{\text{IN}} = 11 \text{ to } 40 \text{ V}$

### PWM Comparator

Item	Symbol	Min	Typ	Max	Unit	Test Condition
Maximum duty cycle	Du	80	—	—	%	
Duty cycle accuracy	Ddev	—	$\pm 1.0$	$\pm 6$	%	$R_1 = 11 \text{ k}\Omega$ , $R_2 = 39 \text{ k}\Omega$
Input bias current	$I_B$	—	—	2.0	$\mu\text{A}$	$V_{\text{EI}} = 4 \text{ V}$ , $V_{\text{DB}} = 0 \text{ V}$ or $V_{\text{EI}} = 0 \text{ V}$ , $V_{\text{DB}} = 4 \text{ V}$

### Output Driver

Item	Symbol	Min	Typ	Max	Unit	Test Condition
Sink current at $V_{\text{in}}$ low	$I_{\text{OS(Low)}}$	1.0	1.5	—	mA	$V_{\text{IN}} = 6 \text{ V}$ , $V_{\text{OUT}} = 0.4 \text{ V}$
Output low level	$V_{\text{OL}}$	—	0.86	1.4	V	$I_{\text{O(sink)}} = 10 \text{ mA}$
Output high level	$V_{\text{OH}}$	$V_{\text{IN}} - 2.2$	—	—	V	$I_{\text{O(source)}} = 10 \text{ mA}$
Output rising time	$t_r$	—	80	300	ns	Figure 5
Output falling time	$t_f$	—	40	200	ns	Figure 5
High level threshold	$V_{\text{THH}}$	9	10	11	V	UVL characteristics
Low level threshold	$V_{\text{THL}}$	7.3	8	9	V	UVL characteristics
Hysteresis width	$V_{\text{HRS}}$	1.5	2.0	2.5	V	UVL characteristics

### Total Current

Item	Symbol	Min	Typ	Max	Unit	Test Condition
Standby current	$I_{\text{CCS}}$	—	1.5	2.0	mA	Figure 4
Operation current	$V_{\text{CCL}}$	3.0	5.0	7.0	mA	$R_1 = 11 \text{ k}\Omega$ , $R_2 = 39 \text{ k}\Omega$ , $V_{\text{IN}} = 20 \text{ V}$ Figure 4

## HA16654A, HA16664A Series

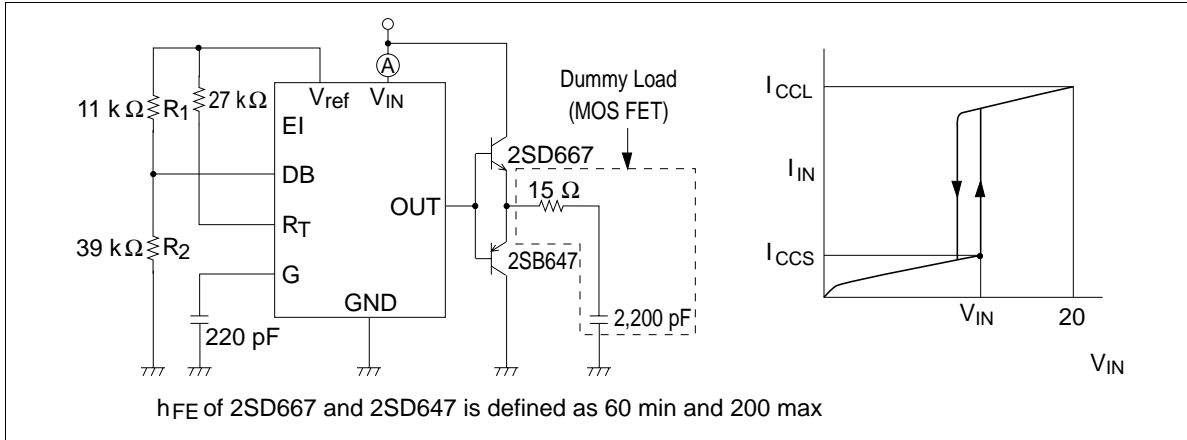

**Figure 4**  $I_{CCS} \cdot I_{CCL}$  Measurement Circuit

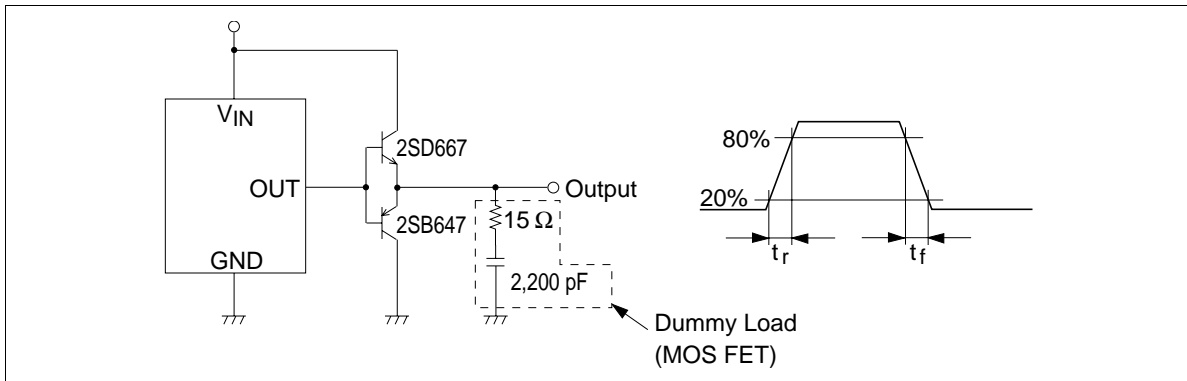
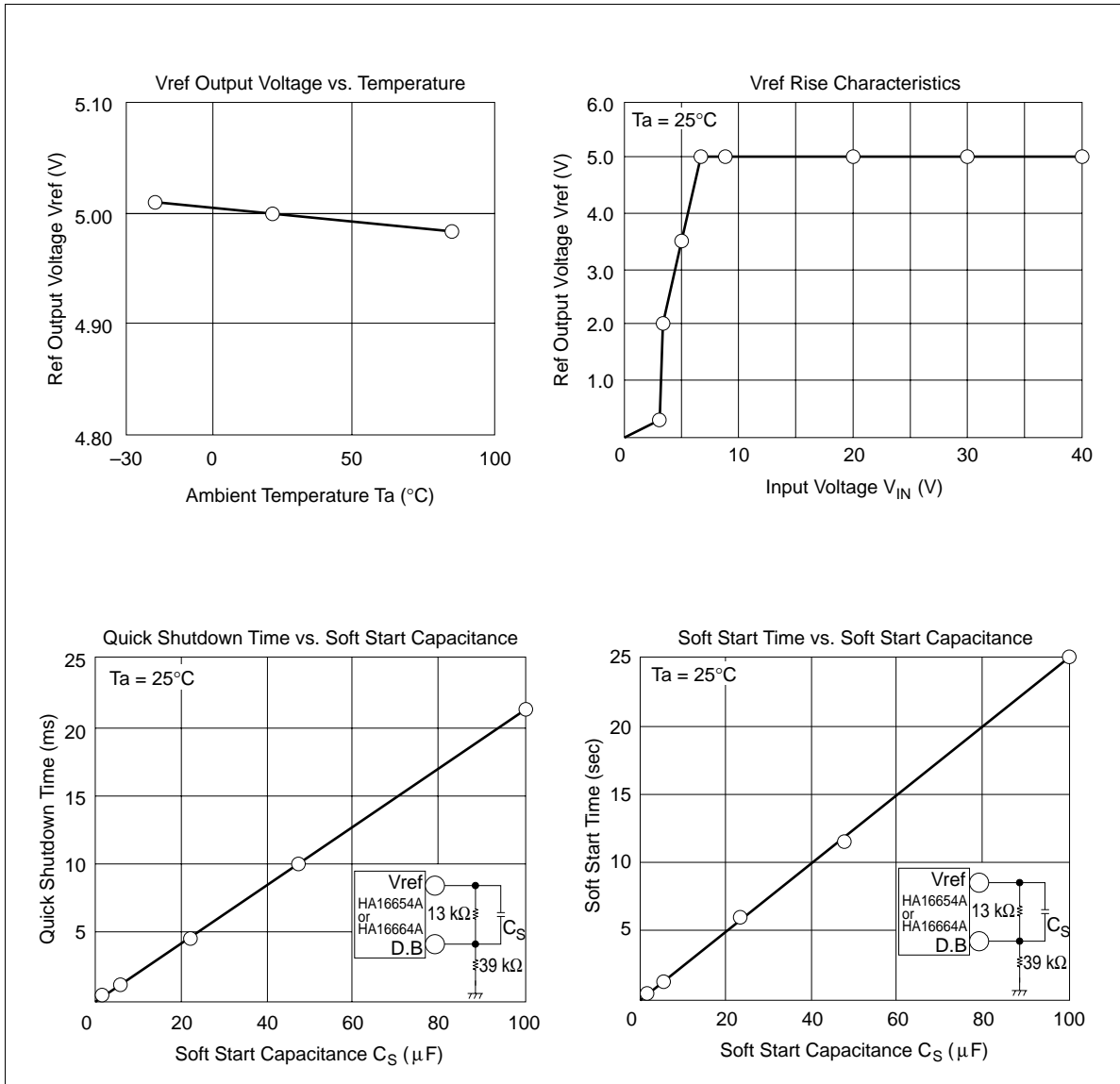

**Figure 5**  $t_r \cdot t_f$  Measurement Circuit



# HA16654A, HA16664A Series

## Characteristic Curves



# HA16654A, HA16664A Series

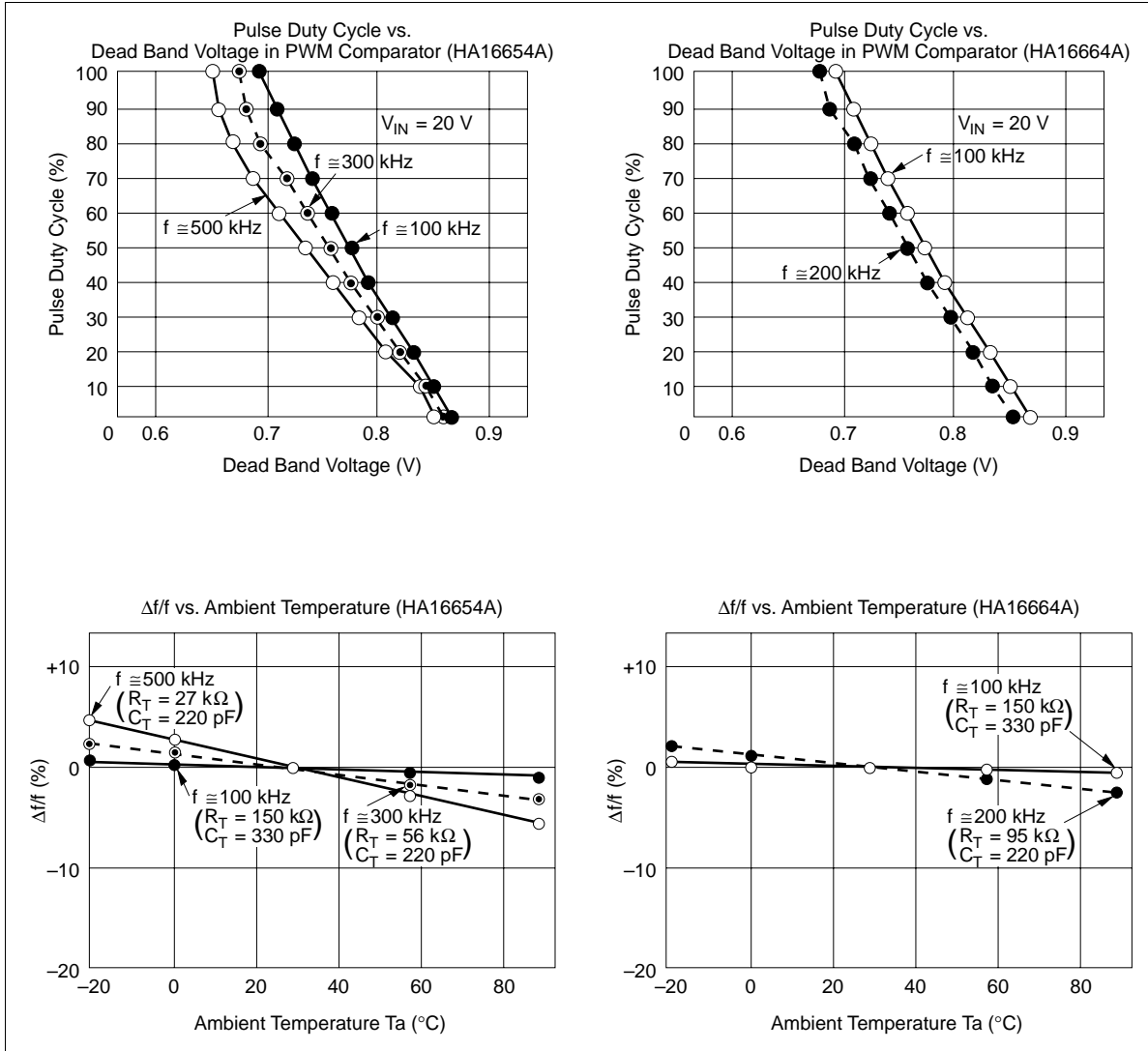

## HA16654A, HA16664A Series

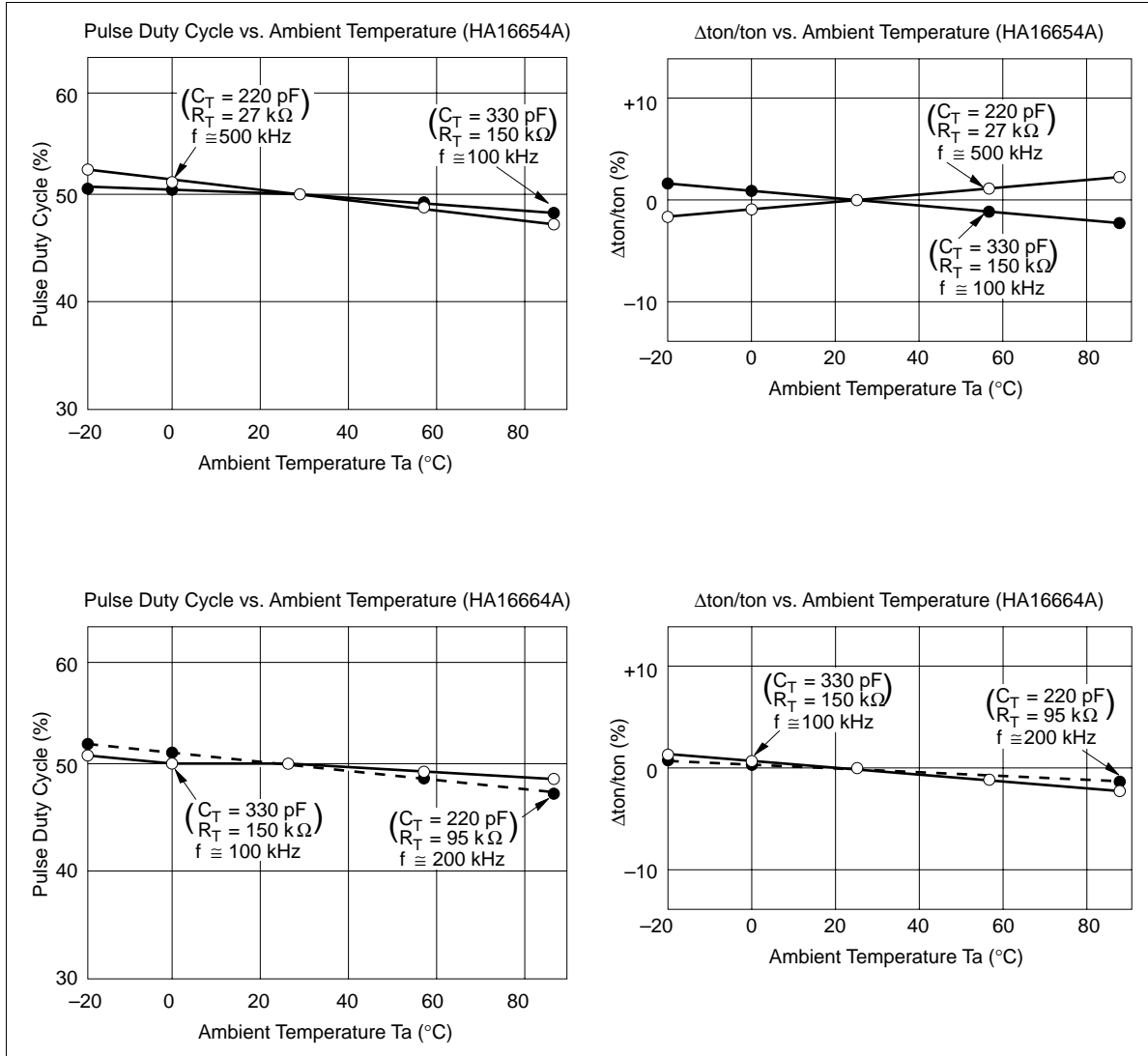

## HA16654A, HA16664A Series

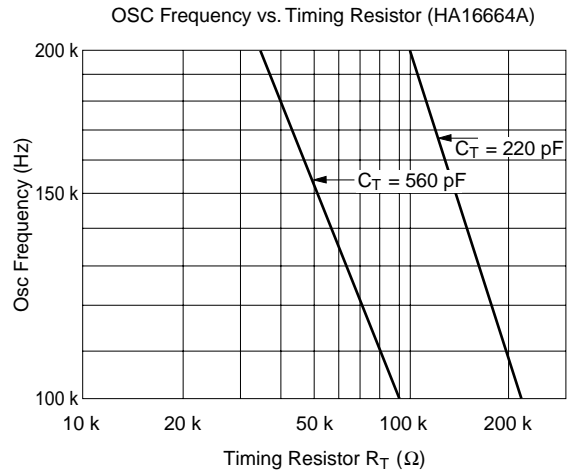
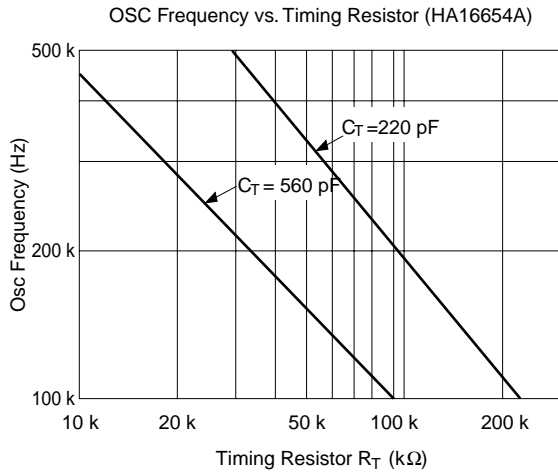

Formula for the oscillation frequency  $f$

$$f = 1 / [ \{ C_T (R_T + 1 \times 10^3)(a \cdot R_T + b) / (V_{ref} - V_{BE}) \} + 100 \times 10^{-9} ]$$

$C_T$  : Timing capacitor (F)

$R_T$  : Timing resistor ( $\Omega$ )

$V_{ref}$  : Reference voltage 5.0 (V) (Typ)

$V_{BE}$  : Base-emitter voltage 0.65 (V) (Typ)

The following table show empirical values of  $a$  and  $b$  for different values of  $C_T$ .

$C_T$ (pF)	$a$	$b$
220	$-2.30 \times 10^{-6}$	1.247
560	$-8.37 \times 10^{-6}$	1.575

Also,  
 $f \approx 4.35 / (C_T \cdot R_T)$

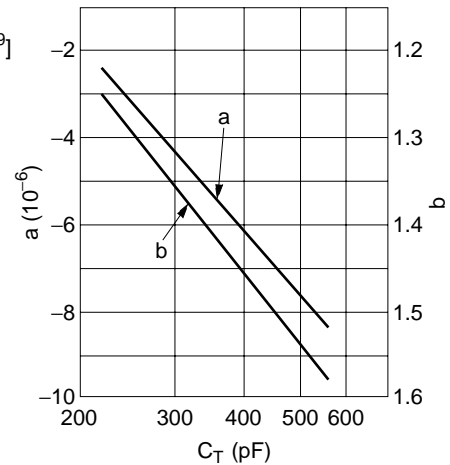

## HA16654A, HA16664A Series

### $V_{IN}$ Bias Point

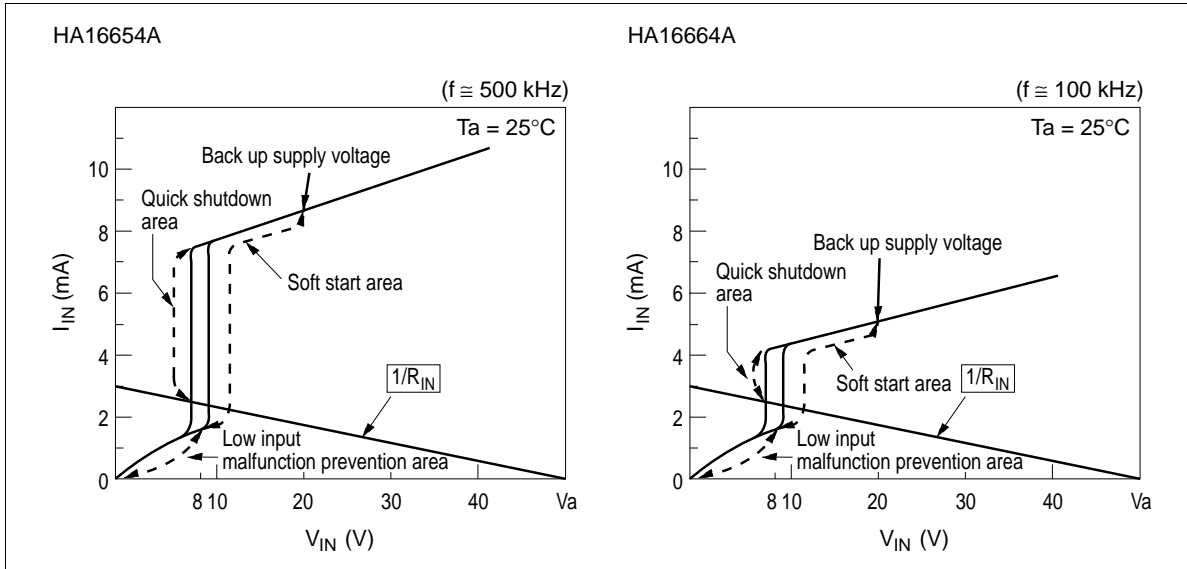

### Primary Control Forward Converter System

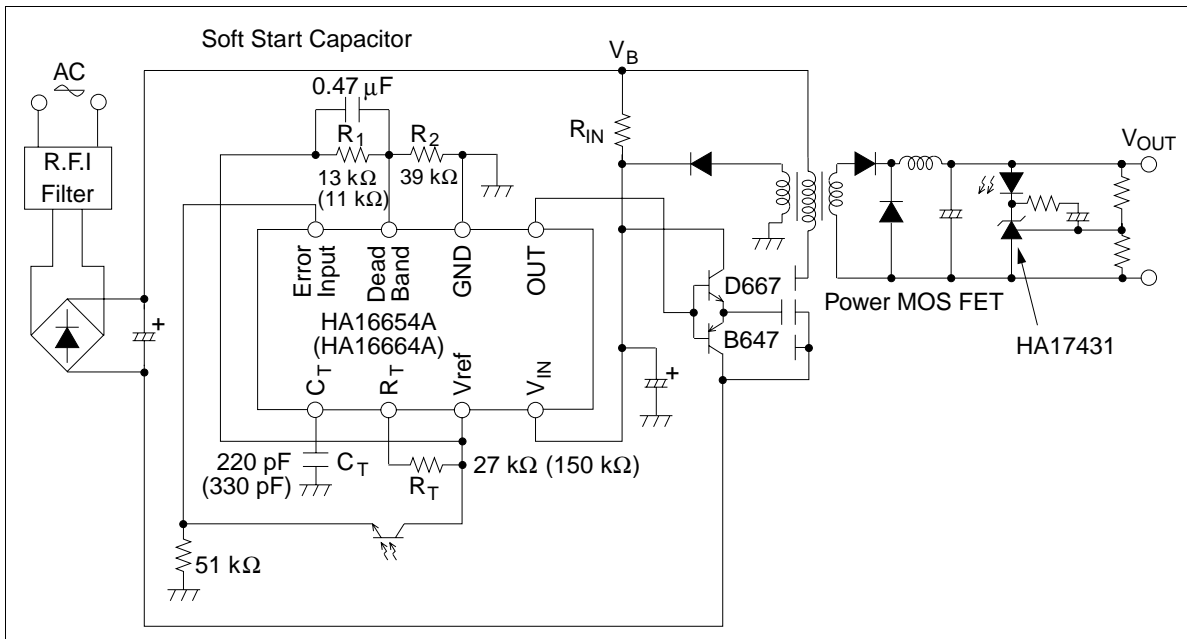

# HA16654A, HA16664A Series

## Package Dimensions

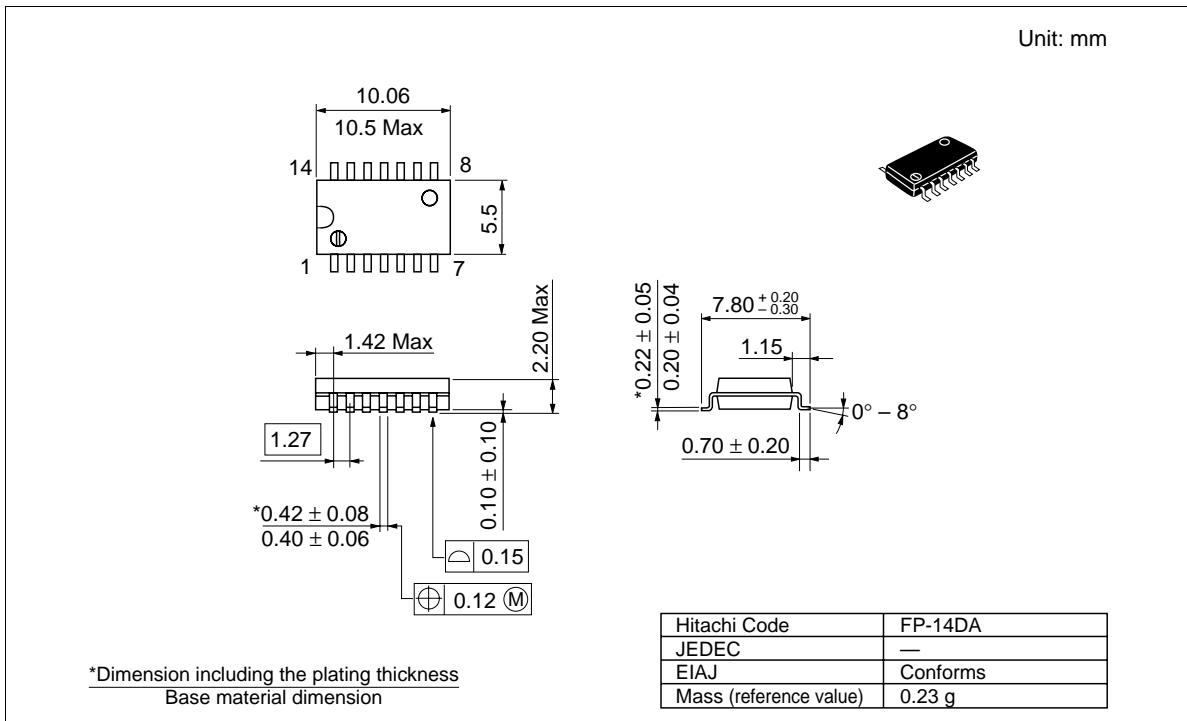
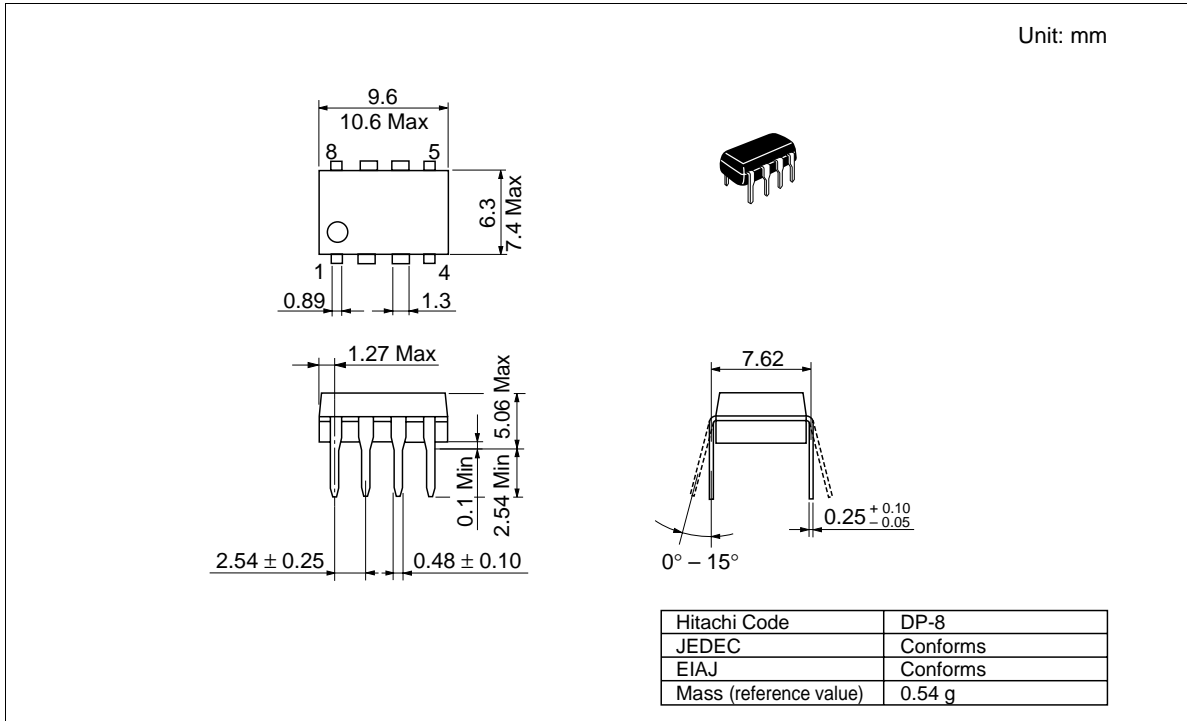

**Cautions**

1. Hitachi neither warrants nor grants licenses of any rights of Hitachi's or any third party's patent, copyright, trademark, or other intellectual property rights for information contained in this document. Hitachi bears no responsibility for problems that may arise with third party's rights, including intellectual property rights, in connection with use of the information contained in this document.
2. Products and product specifications may be subject to change without notice. Confirm that you have received the latest product standards or specifications before final design, purchase or use.
3. Hitachi makes every attempt to ensure that its products are of high quality and reliability. However, contact Hitachi's sales office before using the product in an application that demands especially high quality and reliability or where its failure or malfunction may directly threaten human life or cause risk of bodily injury, such as aerospace, aeronautics, nuclear power, combustion control, transportation, traffic, safety equipment or medical equipment for life support.
4. Design your application so that the product is used within the ranges guaranteed by Hitachi particularly for maximum rating, operating supply voltage range, heat radiation characteristics, installation conditions and other characteristics. Hitachi bears no responsibility for failure or damage when used beyond the guaranteed ranges. Even within the guaranteed ranges, consider normally foreseeable failure rates or failure modes in semiconductor devices and employ systemic measures such as fail-safes, so that the equipment incorporating Hitachi product does not cause bodily injury, fire or other consequential damage due to operation of the Hitachi product.
5. This product is not designed to be radiation resistant.
6. No one is permitted to reproduce or duplicate, in any form, the whole or part of this document without written approval from Hitachi.
7. Contact Hitachi's sales office for any questions regarding this document or Hitachi semiconductor products.

---

---

**HITACHI****Hitachi, Ltd.**

Semiconductor & Integrated Circuits.  
Nippon Bldg., 2-6-2, Ohte-machi, Chiyoda-ku, Tokyo 100-0004, Japan  
Tel: Tokyo (03) 3270-2111 Fax: (03) 3270-5109

URL   NorthAmerica   : <http://semiconductor.hitachi.com/>  
      Europe           : <http://www.hitachi-eu.com/hel/ecg>  
      Asia (Singapore) : <http://www.has.hitachi.com.sg/grp3/sicd/index.htm>  
      Asia (Taiwan)    : [http://www.hitachi.com.tw/E/Product/SICD\\_Frame.htm](http://www.hitachi.com.tw/E/Product/SICD_Frame.htm)  
      Asia (HongKong) : <http://www.hitachi.com.hk/eng/bo/grp3/index.htm>  
      Japan            : <http://www.hitachi.co.jp/Sicd/indx.htm>

**For further information write to:**

Hitachi Semiconductor  
(America) Inc.  
179 East Tasman Drive,  
San Jose, CA 95134  
Tel: <1> (408) 433-1990  
Fax: <1> (408) 433-0223

Hitachi Europe GmbH  
Electronic components Group  
Dornacher Straße 3  
D-85622 Feldkirchen, Munich  
Germany  
Tel: <49> (89) 9 9180-0  
Fax: <49> (89) 9 29 30 00  
  
Hitachi Europe Ltd.  
Electronic Components Group.  
Whitebrook Park  
Lower Cookham Road  
Maidenhead  
Berkshire SL6 8YA, United Kingdom  
Tel: <44> (1628) 585000  
Fax: <44> (1628) 778322

Hitachi Asia Pte. Ltd.  
16 Collyer Quay #20-00  
Hitachi Tower  
Singapore 049318  
Tel: 535-2100  
Fax: 535-1533

Hitachi Asia Ltd.  
Taipei Branch Office  
3F, Hung Kuo Building, No.167,  
Tun-Hwa North Road, Taipei (105)  
Tel: <886> (2) 2718-3666  
Fax: <886> (2) 2718-8180

Hitachi Asia (Hong Kong) Ltd.  
Group III (Electronic Components)  
7/F., North Tower, World Finance Centre,  
Harbour City, Canton Road, Tsim Sha Tsui,  
Kowloon, Hong Kong  
Tel: <852> (2) 735 9218  
Fax: <852> (2) 730 0281  
Telex: 40815 HITEC HX