



SPX1084

5A Low Dropout Voltage Regulator Adjustable & Fixed Output, Fast Response

FEATURES

- Adjustable Output Down To 1.2V
- Fixed Output Voltages 1.5, 2.5, 3.3 & 5.0V
- Output Current Of 5A
- Low Dropout Voltage 1.1V Typ.
- Extremely Tight Load And Line Regulation
- Current & Thermal Limiting
- Standard 3-Terminal Low Cost TO-220 & TO-263
- Similar To Industry Standard LT1085/LT1585

APPLICATIONS

- Powering VGA & Sound Card
- Power PC™ Supplies
- SMPS Post-Regulator
- High Efficiency “Green” Computer Systems
- High Efficiency Linear Power Supplies
- Portable Instrumentation
- Constant Current Regulators
- Adjustable Power Supplies
- Battery charger

PRODUCT DESCRIPTION

The SPX1084 are low power 5A adjustable and fixed voltage regulators with 30V maximum V_{IN} . They are very easy to use. It requires only 2 external resistors to set the output voltage for adjustable version. The SPX1084 are designed for low voltage applications that offers lower dropout voltage and faster transient response. This device is an excellent choice for use in powering low voltage microprocessor that require a lower dropout, faster transient response to regulate from +2.5V to 3.8V supplies and as a post regulator for switching supplies applications. The SPX1084 features low dropout of a maximum of 1.2 volts.

The SPX1084 offers full protection against over-current faults, reversed input polarity, reversed load insertion, and positive and negative transient voltage. On-Chip trimming adjusts the reference voltage to 1%. The I_Q of this device flows into load, which increases efficiency.

The SPX1084 are offered in 3-pin TO-220 and TO-263 packages compatible with other 3 terminal regulators. For a similar 5A low dropout voltage regulator refer to the SPX1084 datasheet. Also for higher current requirements, refer to the SPX1084 datasheet.

PIN CONNECTIONS

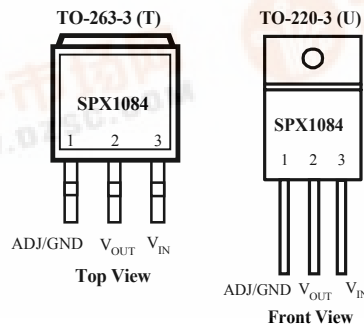

SPX1084

ABSOLUTE MAXIMUM RATINGS

Lead Temp. (Soldering, 10 Seconds)	300°C
Storage Temperature Range	-65° to +150°C
Operating Junction Temperature Range	
SPX1084 Control Section	-45°C +125°C
SPX1084 Power Transistor	-45°C +150°C

Input Voltage	30V
Input to Output Voltage Differential	30V

ELECTRICAL CHARACTERISTICS (NOTE 1) at I_{OUT} = 10mA, T_a = 25°C, unless otherwise specified.

PARAMETER	CONDITIONS	Typ	SPX1084A		SPX1084		UNITS
			Min	Max	Min	Max	
1.5V Version							
Output Voltage (Note 2)	SPX1084-1.5V, 0 < I _{OUT} < 5A, 3.3V < V _{IN} < 25V	1.5	1.485	1.515	1.47	1.53	V
			1.47	1.53	1.455	1.545	
2.5V Version							
Output Voltage (Note 2)	SPX1084-2.5V, 0 < I _{OUT} < 5A, 4.0V < V _{IN} < 25V	2.5	2.475	2.525	2.45	2.55	V
			2.45	2.55	2.425	2.575	
3.3V Version							
Output Voltage (Note 2)	SPX1084-3.3V, 0 < I _{OUT} < 5A, 4.8V < V _{IN} < 25V	3.3	3.267	3.333	3.234	3.366	V
			3.234	3.366	3.069	3.399	
5.0V Version							
Output Voltage (Note 2)	SPX1084-5.0V, 0 ≤ I _{OUT} ≤ 5A, 6.5V ≤ V _{IN} ≤ 25V	5	4.950	5.050	4.9	5.1	V
			4.900	5.100	4.65	5.15	
Adjustable Version							
Reference Voltage (V _{REF})	1.5V ≤ (V _{IN} - V _{OUT}) ≤ 25V, 10mA ≤ I _{OUT} ≤ 5A	1.250	1.238	1.262	1.225	1.270	V
		1.250	1.225	1.270	1.212	1.288	
All Voltage Options							
Min. Load Current (Note 3)	1.5V ≤ (V _{IN} - V _{OUT}) ≤ 25V	5		10		10	V
Line Regulation (ΔV _{REF} (V _{in}))	2.75V ≤ V _{IN} ≤ 25V, I _{OUT} = 10mA, T _J = 25°C (Note 3)	0.005		0.2		0.2	%
	V _{IN} ≤ 25V, I _{OUT} = 0mA, T _J = 25°C (Note 2)	0.005		0.2		0.2	
Load Regulation (ΔV _{REF} (I _{OUT}))	10mA ≤ I _{OUT} ≤ 5A, (V _{IN} - V _{OUT}) = 3V, T _J = 25°C (Note 3)	0.05		0.7		0.7	%
	0 ≤ I _{OUT} ≤ 5A, V _{IN} = 7V, T _J = 25°C (Note 2)	0.05		0.3		0.3	
Dropout Voltage	ΔV _{REF} = 1% I _{OUT} = 5A (Note 3) I _{OUT} < 5A (Note 2)	1.2		1.5		1.5	
Current Limit I _{OUT} (MAX)	V _{IN} = 7V 1.4V ≤ (V _{IN} - V _{OUT}) (Note 3)	6	5.2		5.2		A
Long Term Stability	T _A = 125°C, 1000 Hrs.	0.3 (Note 2)		1		1	%
Thermal Regulation (ΔV _{OUT} (Pwr))	T _A = 25°C, 20 ms pulse	0.01		0.020		0.020	%/W
Temperature Stability (ΔV _{OUT} (T))		0.25					%
Output Noise, RMS	10Hz to 10kHz T _A = 25°C	0.003					% V _O
Thermal Resistance	TO-220 Junction to Tab Junction to Ambient DD Package Junction to Tab Junction to Ambient	3.0 60 3.0 60		3.0 60 3.0 60		3.0 60 3.0 60	°C/W

The Bold specifications apply to the full operating temperature range.

Note 1: Changes in output voltage due to heating effects are covered under the specification for thermal regulation.

Note 2: Fixed Version Only

Note 3: Adjustable Version Only

APPLICATION HINTS

The SPX1084 incorporates protection against over-current faults, reversed load insertion, over temperature operation, and positive and negative transient voltage. However, the use of an output capacitor is required in order to insure the stability and the performances.

Stability

The output capacitor is part of the regulator's frequency compensation system. Either a 220 μ F aluminum electrolytic capacitor or a 47 μ F solid tantalum capacitor between the output terminal and ground guarantees stable operation for all operating conditions.

However, in order to minimize overshoot and undershoot, and therefore optimize the design, please refer to the section 'Ripple Rejection'.

Ripple Rejection

Ripple rejection can be improved by adding a capacitor between the ADJ pin and ground. When ADJ pin bypassing is used, the value of the output capacitor required increases to its maximum (220 μ F for an aluminum electrolytic capacitor, or 47 μ F for a solid tantalum capacitor). If the ADJ pin is not bypass, the value of the output capacitor can be lowered to 100 μ F for an electrolytic aluminum capacitor or 15 μ F for a solid tantalum capacitor.

However the value of the ADJ-bypass capacitor should be chosen with respect to the following equation:

$$C = 1 / (6.28 * F_R * R_1)$$

Where C = value of the capacitor in Farads (select an equal or larger standard value),

F_R = ripple frequency in Hz,

R_1 = value of resistor R_1 in Ohms.

If an ADJ-bypass capacitor is use, the amplitude of the output ripple will be independent of the output voltage. If an ADJ-bypass capacitor is not used, the output ripple will be proportional to the ratio of the output voltage to the reference voltage:

$$M = V_{OUT} / V_{REF}$$

Where M = multiplier for the ripple seen when the ADJ pin is optimally bypassed.

V_{REF} = Reference Voltage

Reducing parasitic resistance and inductance

One solution to minimize parasitic resistance and inductance is to connect in parallel capacitors. This arrangement will improve the transient response of the power supply if your system requires rapidly changing current load condition.

Thermal Consideration

Although the SPX1084 offers some limiting circuitry for overload conditions, it is necessary not to exceed the maximum junction temperature, and therefore to be careful about thermal resistance. The heat flow will follow the lowest resistance path, which is the Junction-to-case thermal resistance. In order to insure the best thermal flow of the component, a proper mounting is required. Note that the case of the device is electrically connected to the output. In case the case has to be electrically isolated, a thermally conductive spacer can be used. However do not forget to consider its contribution to thermal resistance.

Assuming:

$$V_{IN} = 7V, V_{OUT} = 5V, I_{OUT} = 1.5A, T_A = 50^{\circ}C/W,$$

$$\theta_{Heatsink Case} = 6^{\circ}C/W, \theta_{Heatsink Case} = 0.5^{\circ}C/W, \theta_{JC} = 3^{\circ}C/W$$

Power dissipation under this condition

$$P_D = (V_{IN} - V_{OUT}) * I_{OUT} = 7.5W$$

Junction Temperature

$$T_J = T_A + P_D * (\theta_{Case- HS} + \theta_{HS} + \theta_{JC})$$

For the Control Sections

$$T_J = 50 + 7.5*(0.5+6=3) = 121.25^{\circ}C$$

$$121.25^{\circ}C < T_{J(max)} \text{ for the Control \& Power Sections.}$$

In both case reliable operation is insured by adequate junction temperature.

Basic Adjustable Regulator

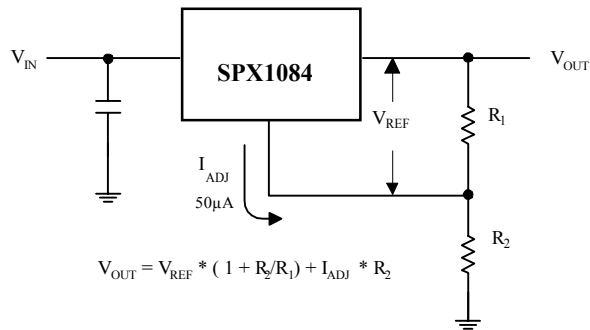

Fig.2 Basic Adjustable Regulator

Output Voltage

Consider Figure 2. The resistance R_1 generates a constant current flow, normally the specified load current of 10mA. This current will go through the resistance R_2 to set the overall output voltage. The current I_{ADJ} is very small and constant. Therefore its contribution to the overall output voltage is very small and can generally be ignored

Load Regulation

Parasitic line resistance can degrade load regulation. In order not to affect the behavior of the regulator, it is best to connect directly the R_1 resistance from the resistor divider to the case, and not to the load. For the same reason, it is best to connect the resistor R_2 to the Negative side of the load.

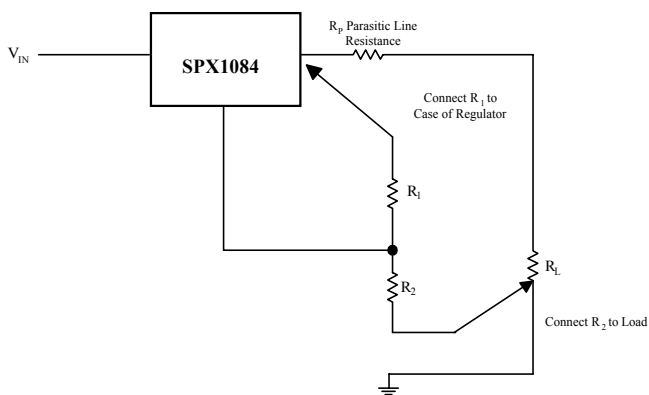

Fig.3 Basic Adjustable Regulator

TYPICAL APPLICATIONS

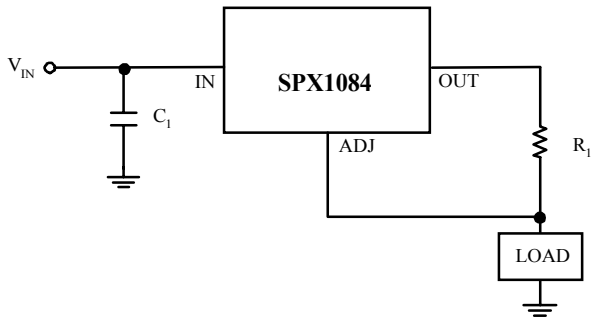

Fig. 4 5A Current output Regulator

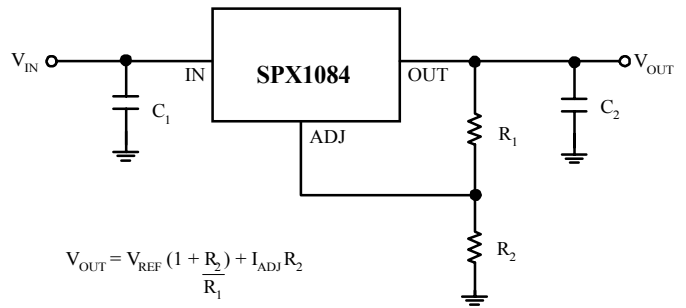

Fig. 5 Typical Adjustable Regulator

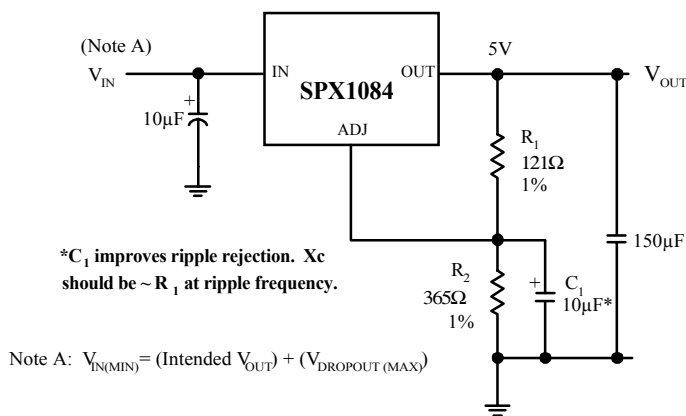

Fig. 6 Improving Ripple Rejection

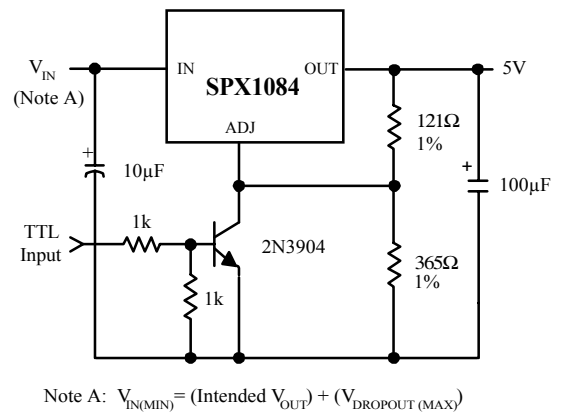

Fig. 7 5V Regulator with Shutdown

ORDERING INFORMATION

Ordering No.	Precision	Output Voltage	Packages
SPX1084U	2%	Adj	3 Lead TO-220
SPX1084U-1.5	2%	1.5V	3 Lead TO-220
SPX1084U-2.5	2%	2.5V	3 Lead TO-220
SPX1084U-3.3	2%	3.3V	3 Lead TO-220
SPX1084U-5.0	2%	5.0V	3 Lead TO-220
SPX1084AU	1%	Adj	3 Lead TO-220
SPX1084AU-1.5	1%	1.5V	3 Lead TO-220
SPX1084AU-2.5	1%	2.5V	3 Lead TO-220
SPX1084AU-3.3	1%	3.3V	3 Lead TO-220
SPX1084AU-5.0	1%	5.0V	3 Lead TO-220
SPX1084T	2%	Adj	3 Lead TO-263
SPX1084T-1.5	2%	1.5V	3 Lead TO-263
SPX1084T-2.5	2%	2.5V	3 Lead TO-263
SPX1084T-3.3	2%	3.3V	3 Lead TO-263
SPX1084T-5.0	2%	5.0V	3 Lead TO-263
SPX1084AT	1%	Adj	3 Lead TO-263
SPX1084AT-1.5	1%	1.5V	3 Lead TO-263
SPX1084AT-2.5	1%	2.5V	3 Lead TO-263
SPX1084AT-3.3	1%	3.3V	3 Lead TO-263
SPX1084AT-5.0	1%	5.0V	3 Lead TO-263



SIGNAL PROCESSING EXCELLENCE

Sipex Corporation

Headquarters and Main Offices:

22 Linnell Circle
Billerica, MA 01821
TEL: (978) 667-8700
FAX: (978) 670-9001
e-mail: sales@sipex.com

233 South Hillview Drive
Milpitas, CA 95035
TEL: (408) 935-7600
FAX: (408) 934-7500