

S7IPL254/I27/064/032J based MCPs

Stacked Multi-Chip Product (MCP) Flash Memory and RAM
256M/I28/64/32 Megabit (16/8/4/2M x 16-bit) CMOS 3.0 Volt-only
Simultaneous Operation Page Mode Flash Memory and
64/32/16/8/4 Megabit (4M/2M/1M/512K/256K x 16-bit) Static
RAM/Pseudo Static RAM



Datasheet

ADVANCE

Distinctive Characteristics

MCP Features

- **Power supply voltage of 2.7 to 3.1 volt**
- **High performance**
 - 55 ns
 - 65 ns (65 ns Flash, 70ns pSRAM)

- **Packages**
 - 7 x 9 x 1.2mm 56 ball FBGA
 - 8 x 11.6 x 1.2mm 64 ball FBGA
 - 8 x 11.6 x 1.4mm 84 ball FBGA
- **Operating Temperature**
 - -25°C to +85°C
 - -40°C to +85°C

General Description

The S71PL series is a product line of stacked Multi-Chip Product (MCP) packages and consists of:

- One or more S29PL (Simultaneous Read/Write) Flash memory die
- pSRAM or SRAM

The 256Mb Flash memory consists of two S29PL127J devices. In this case, CE#f2 is used to access the second Flash and no extra address lines are required.

The products covered by this document are listed in the table below:

		Flash Memory Density			
		32Mb	64Mb	128Mb	256Mb
pSRAM Density	4Mb	S71PL032J40			
	8Mb	S71PL032J80	S71PL064J80		
	16Mb	S71PL032JA0	S71PL064JA0	S71PL127JA0	
	32Mb		S71PL064JB0	S71PL127JB0	S71PL254JB0
	64Mb			S71PL127JC0	S71PL254JC0

		Flash Memory Density	
		32Mb	64Mb
SRAM Density (Note)	4Mb	S71PL032J04	
	8Mb	S71PL032J08	S71PL064J08

Note: Not recommended for new designs; use pSRAM based MCPs instead.

Product Selector Guide

32Mb Flash Memory

Device-Model#	Flash Access time (ns)	(p)SRAM density	(p)SRAM Access time (ns)	pSRAM type	Package
S71PL032J04-0B	65	4M SRAM	70	SRAM2	TSC056
S71PL032J04-0F	65	4M SRAM	70	SRAM3	TSC056
S71PL032J04-0K	65	4M SRAM	70	SRAM4	TSC056
S71PL032J40-0K	65	4M pSRAM	70	pSRAM4	TLC056
S71PL032J40-07	65	4M pSRAM	70	pSRAM1	TSC056
S71PL032J08-0B	65	8M SRAM	70	SRAM2	TSC056
S71PL032J80-0P	65	8M pSRAM	70	pSRAM5	TSC056
S71PL032J80-07	65	8M pSRAM	70	pSRAM1	TSC056
S71PL032JA0-0K	65	16Mb pSRAM	70	pSRAM1	TSC056
S71PL032JA0-0F	65	16Mb pSRAM	70	pSRAM3	TSC056
S71PL032JA0-0Z	65	32M pSRAM	70	pSRAM7	TLC056

64Mb Flash Memory

Device-Model#	Flash Access time (ns)	(p)SRAM density	(p)SRAM Access time (ns)	(p)SRAM type	Package
S71PL064J08-0B	65	8M SRAM	70	SRAM2	TLC056
S71PL064J08-0U	65	8M SRAM	70	SRAM4	TLC056
S71PL064J80-0K	65	8M pSRAM	70	pSRAM1	TSC056
S71PL064J80-07	65	8M pSRAM	70	pSRAM1	TLC056
S71PL064J80-0P	65	8M pSRAM	70	pSRAM5	TSC056
S71PL064JA0-0Z	65	16M pSRAM	70	pSRAM7	TLC056
S71PL064JA0-0B	65	16M pSRAM	70	SRAM3	TLC056
S71PL064JA0-07	65	16M pSRAM	70	pSRAM1	TLC056
S71PL064JA0-0P	65	16M pSRAM	70	pSRAM7	TLC056
S71PL064JB0-07	65	32M pSRAM	70	pSRAM1	TLC056
S71PL064JB0-0B	65	32M pSRAM	70	pSRAM2	TLC056
S71PL064JB0-0U	65	32M pSRAM	70	pSRAM6	TLC056

128Mb Flash Memory

Device-Model#	Flash Access time (ns)	pSRAM density	pSRAM Access time (ns)	pSRAM type	Package
S71PL127JA0-9P	65	16M pSRAM	70	pSRAM7	TLA064
S71PL127JA0-9Z	65	16M pSRAM	70	pSRAM7	TLA064
S71PL127JA0-97	65	16M pSRAM	70	pSRAM1	TLA064
S71PL127JB0-97	65	32M pSRAM	70	pSRAM1	TLA064
S71PL127JB0-9Z	65	32M pSRAM	70	pSRAM7	TLA064
S71PL127JB0-9U	65	32M pSRAM	70	pSRAM6	TLA064
S71PL127JB0-9B	65	32M pSRAM	70	pSRAM2	TLA064
S71PL127JC0-97	65	64M pSRAM	70	pSRAM1	TLA064
S71PL127JC0-9Z	65	64M pSRAM	70	pSRAM7	TLA064
S71PL127JC0-9U	65	64M pSRAM	70	pSRAM6	TLA064

256Mb Flash Memory (2xS29PL127J)

Device-Model#	Flash Access time (ns)	pSRAM density	pSRAM Access time (ns)	pSRAM type	Package
S71PL254JB0-T7	65	32M pSRAM	70	pSRAM1	FTA084
S71PL254JB0-TB	65	32M pSRAM	70	pSRAM2	FTA084
S71PL254JB0-TU	65	32M pSRAM	70	pSRAM6	FTA084
S71PL254JC0-TB	65	64M pSRAM	70	pSRAM2	FTA084
S71PL254JC0-TZ	65	64M pSRAM	70	pSRAM7	FTA084

S7IPL254/I27/064/032J based MCPs

Distinctive Characteristics 1
MCP Features 1
General Description 1
Product Selector Guide 2
32Mb Flash Memory 2
64Mb Flash Memory 2
128Mb Flash Memory 3
256Mb Flash Memory (2xS29PLI27J) 3
Connection Diagram (S7IPL032J) 9
Connection Diagram (S7IPL064J) 10
Connection Diagram (S7IPLI27J) 11
Connection Diagram (S7IPL254J) 12
Special Handling Instructions For FBGA Package 12
Pin Description 13
Logic Symbol 13
Ordering Information 14
Physical Dimensions 20
TLC056—56-ball Fine-Pitch Ball Grid Array (FBGA)
9 x 7mm Package 20
TSC056—56-ball Fine-Pitch Ball Grid Array (FBGA)
9 x 7mm Package 21
TLA064—64-ball Fine-Pitch Ball Grid Array (FBGA)
8 x 11.6mm Package 22
TSB064—64-ball Fine-Pitch Ball Grid Array (FBGA)
8 x 11.6 mm Package 23
FTA084—84-ball Fine-Pitch Ball Grid Array (FBGA)
8 x 11.6mm 24

S29PLI27J/S29PL064J/S29PL032J for MCP

General Description 27
Simultaneous Read/Write Operation with Zero Latency 27
Page Mode Features 27
Standard Flash Memory Features 27
Product Selector Guide 29
Block Diagram 30
Simultaneous Read/Write Block Diagram 31
Pin Description 32
Logic Symbol 32
Device Bus Operations 33
Table 1. PL127J Device Bus Operations 33
Requirements for Reading Array Data 33
Random Read (Non-Page Read) 33
Page Mode Read 34
Table 2. Page Select 34
Simultaneous Read/Write Operation 34
Table 3. Bank Select 34
Writing Commands/Command Sequences 35
Accelerated Program Operation 35
Autoselect Functions 35
Standby Mode 35
Automatic Sleep Mode 36
RESET#: Hardware Reset Pin 36
Table 4. PL127J Sector Architecture 37
Table 5. PL064J Sector Architecture 44
Table 6. PL032J Sector Architecture 47
Table 7. Secured Silicon Sector Addresses 48
Autoselect Mode 49

Table 8. Autoselect Codes (High Voltage Method) 49
Table 9. PL127J Boot Sector/Sector Block Addresses for Protection/Unprotection 50
Table 10. PL064J Boot Sector/Sector Block Addresses for Protection/Unprotection 51
Table 11. PL032J Boot Sector/Sector Block Addresses for Protection/Unprotection 52
Selecting a Sector Protection Mode 52
Table 12. Sector Protection Schemes 53
Sector Protection 53
Sector Protection Schemes 53
Password Sector Protection 53
WP# Hardware Protection 53
Selecting a Sector Protection Mode 53
Persistent Sector Protection 54
Persistent Protection Bit (PPB) 54
Persistent Protection Bit Lock (PPB Lock) 54
Persistent Sector Protection Mode Locking Bit 56
Password Protection Mode 56
Password and Password Mode Locking Bit 56
64-bit Password 57
Write Protect (WP#) 57
Persistent Protection Bit Lock 57
High Voltage Sector Protection 58
Figure 1. In-System Sector Protection/Sector Unprotection Algorithms 59
Temporary Sector Unprotect 60
Figure 2. Temporary Sector Unprotect Operation 60
Secured Silicon Sector Flash Memory Region 60
Factory-Locked Area (64 words) 61
Customer-Lockable Area (64 words) 61
Secured Silicon Sector Protection Bits 61
Figure 3. Secured Silicon Sector Protect Verify 62
Hardware Data Protection 62
Low VCC Write Inhibit 62
Write Pulse “Glitch” Protection 62
Logical Inhibit 62
Power-Up Write Inhibit 62
Common Flash Memory Interface (CFI) 63
Table 13. CFI Query Identification String 63
Table 14. System Interface String 64
Table 15. Device Geometry Definition 64
Table 16. Primary Vendor-Specific Extended Query 65
Command Definitions 66
Reading Array Data 66
Reset Command 66
Autoselect Command Sequence 67
Enter Secured Silicon Sector/Exit Secured Silicon Sector Command Sequence 67
Word Program Command Sequence 67
Unlock Bypass Command Sequence 68
Figure 4. Program Operation 69
Chip Erase Command Sequence 69
Sector Erase Command Sequence 70
Figure 5. Erase Operation 71
Erase Suspend/Erase Resume Commands 71
Command Definitions Tables 72
Table 17. Memory Array Command Definitions 72
Table 18. Sector Protection Command Definitions 73
Write Operation Status 74
DQ7: Data# Polling 75

Figure 6. Data# Polling Algorithm..... 76
 RY/BY#: Ready/Busy#76
 DQ6: Toggle Bit I76
 Figure 7. Toggle Bit Algorithm..... 78
 DQ2: Toggle Bit II78
 Reading Toggle Bits DQ6/DQ278
 DQ5: Exceeded Timing Limits79
 DQ3: Sector Erase Timer79
 Table 19. Write Operation Status 80
Absolute Maximum Ratings **81**
 Figure 8. Maximum Overshoot Waveforms..... 81
Operating Ranges **82**
 Industrial (I) Devices 82
 Wireless Devices 82
 Supply Voltages 82
DC Characteristics **83**
 Table 20. CMOS Compatible 83
AC Characteristic **84**
 Test Conditions 84
 Figure 9. Test Setups..... 84
 Table 21. Test Specifications 84
 Switching Waveforms 85
 Table 22. Key to Switching Waveforms 85
 Figure 10. Input Waveforms and Measurement Levels..... 85
 VCC RampRate 85
 Read Operations 86
 Table 23. Read-Only Operations 86
 Figure 11. Read Operation Timings..... 86
 Figure 12. Page Read Operation Timings 87
 Reset 87
 Table 24. Hardware Reset (RESET#) 87
 Figure 13. Reset Timings..... 88
 Erase/Program Operations 89
 Table 25. Erase and Program Operations 89
 Timing Diagrams 90
 Figure 14. Program Operation Timings..... 90
 Figure 15. Accelerated Program Timing Diagram 90
 Figure 16. Chip/Sector Erase Operation Timings..... 91
 Figure 17. Back-to-back Read/Write Cycle Timings 91
 Figure 18. Data# Polling Timings
 (During Embedded Algorithms) 92
 Figure 19. Toggle Bit Timings (During Embedded Algorithms) .. 92
 Figure 20. DQ2 vs. DQ6 93
Protect/Unprotect **93**
 Table 26. Temporary Sector Unprotect 93
 Figure 21. Temporary Sector Unprotect Timing Diagram..... 93
 Figure 22. Sector/Sector Block Protect and Unprotect Timing
 Diagram..... 94
 Controlled Erase Operations95
 Table 27. Alternate CE# Controlled Erase and
 Program Operations 95
 Table 28. Alternate CE# Controlled Write (Erase/Program)
 Operation Timings 96
 Table 29. Erase And Programming Performance 97
BGA Pin Capacitance **97**

Type 2 pSRAM

Features **98**
Product Information **98**
Pin Description **98**
Power Up Sequence **99**

Timing Diagrams **99**
 Power Up 99
 Figure 23. Power Up 1 (CS1# Controlled) 99
 Figure 24. Power Up 2 (CS2 Controlled)..... 99
Functional Description **100**
Absolute Maximum Ratings **100**
DC Recommended Operating Conditions **100**
DC and Operating Characteristics **101**
 Common101
 16M pSRAM102
 32M pSRAM102
 64M pSRAM103
AC Operating Conditions **103**
 Test Conditions (Test Load and Test Input/Output Reference)103
 Figure 25. Output Load 103
 ACC Characteristics (Ta = -40°C to 85°C, VCC = 2.7 to 3.1 V)104
Timing Diagrams **105**
 Read Timings105
 Figure 26. Timing Waveform of Read Cycle(1) 105
 Figure 27. Timing Waveform of Read Cycle(2) 105
 Figure 28. Timing Waveform of Read Cycle(2) 105
 Write Timings106
 Figure 29. Write Cycle #1 (WE# Controlled)..... 106
 Figure 30. Write Cycle #2 (CS1# Controlled) 106
 Figure 31. Timing Waveform of Write Cycle(3)
 (CS2 Controlled) 107
 Figure 32. Timing Waveform of Write Cycle(4) (UB#, LB#
 Controlled) 107

pSRAM Type 3

Features **108**
Description **108**
Pin Description **108**
Operation Mode **109**
DC Characteristics **109**
 Table 30. DC Recommended Operating Conditions 109
 Table 31. DC Characteristics (TA = -25°C to 85°C, VDD = 2.6 to
 3.3V) 110
AC Characteristics **110**
 Table 32. AC Characteristics and Operating Conditions (TA = -25°C
 to 85°C, VDD = 2.6 to 3.3V) 110
 Table 33. AC Test Conditions 111
 Figure 33. AC Test Loads 111
 Figure 34. State Diagram 112
 Table 34. Standby Mode Characteristics 112
Timing Diagrams **112**
 Figure 35. Read Cycle 1—Addressed Controlled 112
 Figure 36. Read Cycle 2—CS1# Controlled 113
 Figure 37. Write Cycle 1—WE# Controlled 113
 Figure 38. Write Cycle 2—CS1# Controlled 114
 Figure 39. Write Cycle3—UB#, LB# Controlled 114
 Figure 40. Deep Power-down Mode 115
 Figure 41. Power-up Mode 115
 Figure 42. Abnormal Timing 115

pSRAM Type 4

Features **116**
Functional Description **116**
 Product Portfolio116
Maximum Ratings **117**

Operating Range I17
 Table 35. DC Electrical Characteristics
 (Over the Operating Range) I17
Capacitance I18
Thermal Resistance I18
AC Test Loads and Waveforms I18
 Figure 43. AC Test Loads and Waveforms I18
 Table 36. Switching Characteristics I19
Switching Waveforms I20
 Figure 44. Read Cycle 1 (Address Transition Controlled) I20
 Figure 45. Read Cycle 2 (OE# Controlled) I20
 Figure 46. Write Cycle 1 (WE# Controlled) I21
 Figure 47. Write Cycle 2 (CE#1 or CE2 Controlled) I22
 Figure 48. Write Cycle 3 (WE# Controlled, OE# Low) I23
 Figure 49. Write Cycle 4 (BHE#/BLE# Controlled, OE# Low) .. I23
Truth Table I24
 Table 37. Truth Table I24

pSRAM Type 6

Features I25
Pin Description I25
Functional Description I26
Absolute Maximum Ratings I26
AC Characteristics and Operating Conditions . I27
AC Test Conditions I28
Timing Diagrams I29
 Read Timings I29
 Figure 50. Read Cycle I29
 Figure 51. Page Read Cycle (8 Words Access) I30
 Write Timings I31
 Figure 52. Write Cycle #1 (WE# Controlled) (See Note 8) I31
 Figure 53. Write Cycle #2 (CE# Controlled) (See Note 8) I32
 Deep Power-down Timing I32
 Figure 54. Deep Power Down Timing I32
 Power-on Timing I32
 Figure 55. Power-on Timing I32
 Provisions of Address Skew I33
 Figure 56. Read I33
 Figure 57. Write I33

pSRAM Type 7

Features I34
Pin Description I34
Functional Description I35
Power Down (for 32M, 64M Only) I35
 Power Down I35
 Power Down Program Sequence I36
 Address Key I36
Absolute Maximum Ratings I37
Package Capacitance I37
 Power Down Parameters I41
 Other Timing Parameters I41
 AC Test Conditions I42
 AC Measurement Output Load Circuits I42
 Figure 58. AC Output Load Circuit – 16 Mb I42
 Figure 59. AC Output Load Circuit – 32 Mb and 64 Mb I42
Timing Diagrams I43
 Read Timings I43
 Figure 60. Read Timing #1 (Basic Timing) I43

Figure 61. Read Timing #2 (OE# Address Access) I43
 Figure 62. Read Timing #3 (LB#/UB# Byte Access) I44
 Figure 63. Read Timing #4 (Page Address Access after CE1#
 Control Access for 32M and 64M Only) I44
 Figure 64. Read Timing #5 (Random and Page Address Access for
 32M and 64M Only) I45
 Write Timings I45
 Figure 65. Write Timing #1 (Basic Timing) I45
 Figure 66. Write Timing #2 (WE# Control) I46
 Figure 67. Write Timing #3-1(WE#/LB#/UB# Byte
 Write Control) I46
 Figure 68. Write Timing #3-3 (WE#/LB#/UB# Byte
 Write Control) I47
 Figure 69. Write Timing #3-4 (WE#/LB#/UB# Byte
 Write Control) I47
 Read/Write Timings I48
 Figure 70. Read/Write Timing #1-1 (CE1# Control) I48
 Figure 71. Read / Write Timing #1-2
 (CE1#/WE#/OE# Control) I48
 Figure 72. Read / Write Timing #2 (OE#, WE# Control) I49
 Figure 73. Read / Write Timing #3
 (OE#, WE#, LB#, UB# Control) I49
 Figure 74. Power-up Timing #1 I50
 Figure 75. Power-up Timing #2 I50
 Figure 76. Power Down Entry and Exit Timing I50
 Figure 77. Standby Entry Timing after Read or Write I51
 Figure 78. Power Down Program Timing (for 32M/64M Only). I51

SRAM

Common Features I52
Pin Description I52
Functional Description I53
 4M Version F, 4M version G, 8M version C I53
 Byte Mode I53
Functional Description I54
 8M Version D I54
DC Characteristics I55
 Recommended DC Operating Conditions (Note I) I55
 Capacitance (f=1MHz, T_A=25°C) I55
 DC Operating Characteristics I55
 Common I55
 DC Operating Characteristics I56
 4M Version F I56
 DC Operating Characteristics I56
 4M Version G I56
 DC Operating Characteristics I57
 8M Version C I57
 DC Operating Characteristics I57
 8M Version D I57
AC Operating Conditions I58
 Test Conditions I58
 Figure 79. AC Output Load I58
AC Characteristics I58
 Read/Write Characteristics (V_{CC}=2.7-3.3V) I58
 Data Retention Characteristics (4M Version F) I59
 Data Retention Characteristics (4M Version G) I60
 Data Retention Characteristics (8M Version C) I60
 Data Retention Characteristics (8M Version D) I60
 Timing Diagrams I60
 Figure 80. Timing Waveform of Read Cycle(1) (Address Controlled,
 CS#1=OE#=V_{IL}, CS2=WE#=V_{IH}, UB# and/or LB#=V_{IL}) I60
 Figure 81. Timing Waveform of Read Cycle(2) (WE#=V_{IH}, if BYTE#

is Low, Ignore UB#/LB# Timing) 161
 Figure 82. Timing Waveform of Write Cycle(1) (WE# controlled, if
 BYTE# is Low, Ignore UB#/LB# Timing)..... 161
 Figure 83. Timing Waveform of Write Cycle(2) (CS# controlled, if
 BYTE# is Low, Ignore UB#/LB# Timing)..... 162
 Figure 84. Timing Waveform of Write Cycle(3) (UB#, LB#
 controlled) 162
 Figure 85. Data Retention Waveform 163

pSRAM Type I

Features 164
Functional Description 164
Absolute Maximum Ratings 164
Timing Test Conditions 170
 Output Load Circuit 171
 Figure 86. Output Load Circuit 171
Power Up Sequence 171
Timing Diagrams 183
 Read Cycle 183
 Figure 87. Timing of Read Cycle (CE# = OE# = V_{IL} , WE# = ZZ# =
 V_{IH})..... 183

Figure 88. Timing Waveform of Read
 Cycle (WE# = ZZ# = V_{IH}) 184
 Figure 89. Timing Waveform of Page Mode Read Cycle (WE# = ZZ#
 = V_{IH})..... 185
 Write Cycle 186
 Figure 90. Timing Waveform of Write Cycle (WE# Control, ZZ# =
 V_{IH}) 186
 Figure 91. Timing Waveform of Write Cycle (CE# Control, ZZ# =
 V_{IH}) 186
 Figure 92. Timing Waveform of Page Mode Write Cycle (ZZ# = V_{IH})
 187
 Partial Array Self Refresh (PAR) 188
 Temperature Compensated Refresh (for 64Mb) 188
 Deep Sleep Mode 188
 Reduced Memory Size (for 32M and 16M) 188
 Other Mode Register Settings (for 64M) 189
 Figure 93. Mode Register 189
 Figure 94. Mode Register Update Timings (UB#, LB#, OE# are
 Don't Care)..... 190
 Figure 95. Deep Sleep Mode - Entry/Exit Timings..... 190

Revision Summary

MCP Block Diagram

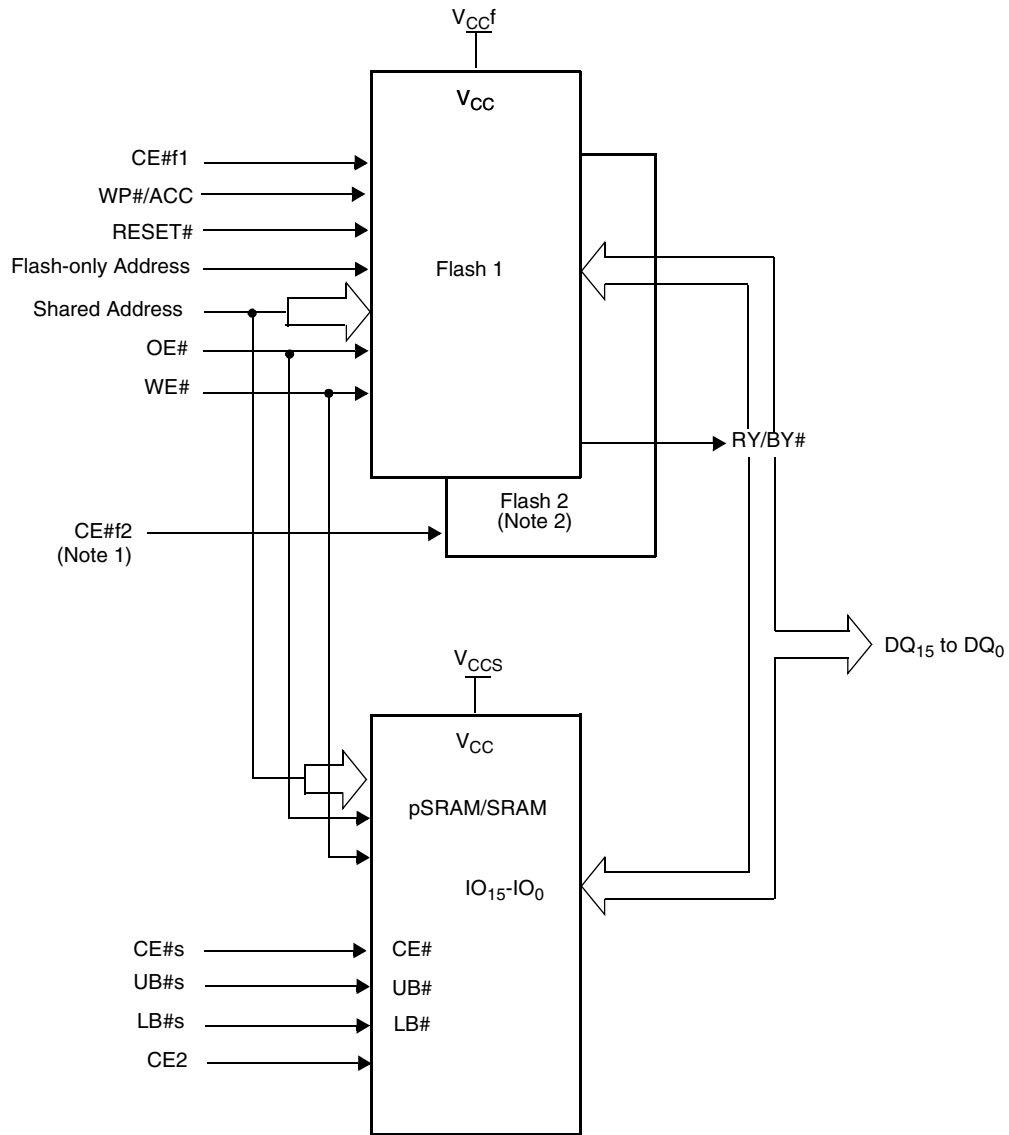

Notes:

1. For 1 Flash + pSRAM, $CE\#f1=CE\#$. For 2 Flash + pSRAM, $CE\#=CE\#f1$ and $CE\#f2$ is the chip-enable for the second Flash.
2. For 256Mb only, Flash 1 = Flash 2 = S29PL127J.

Connection Diagram (S7IPL032J)

56-ball Fine-Pitch Ball Grid Array
(Top View, Balls Facing Down)

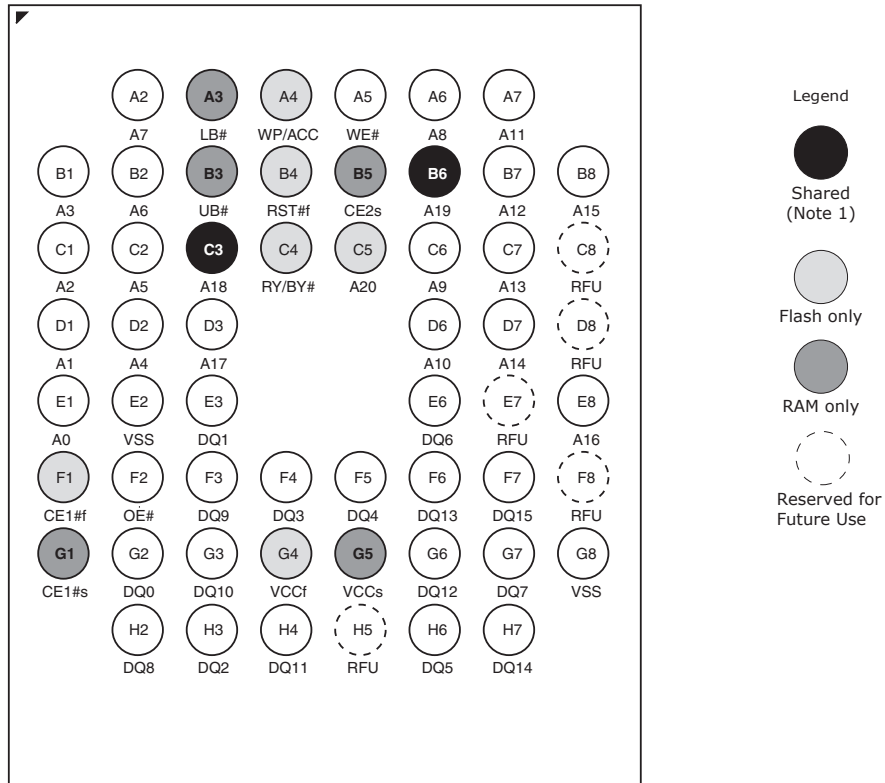

Notes:

- May be shared depending on density.
 - A19 is shared for the 16M pSRAM configuration.
 - A18 is shared for the 8M (p)SRAM and above configurations.
- Connecting all Vcc and Vss balls to Vcc and Vss is recommended.

MCP	Flash-only Addresses	Shared Addresses
S71PL032JA0	A20	A19-A0
S71PL032J80	A20-A19	A18-A0
S71PL032J08	A20-A19	A18-A0
S71PL032J40	A20-A18	A17-A0
S71PL032J04	A20-A18	A17-A0

Connection Diagram (S7IPL064J)

56-ball Fine-Pitch Ball Grid Array
(Top View, Balls Facing Down)

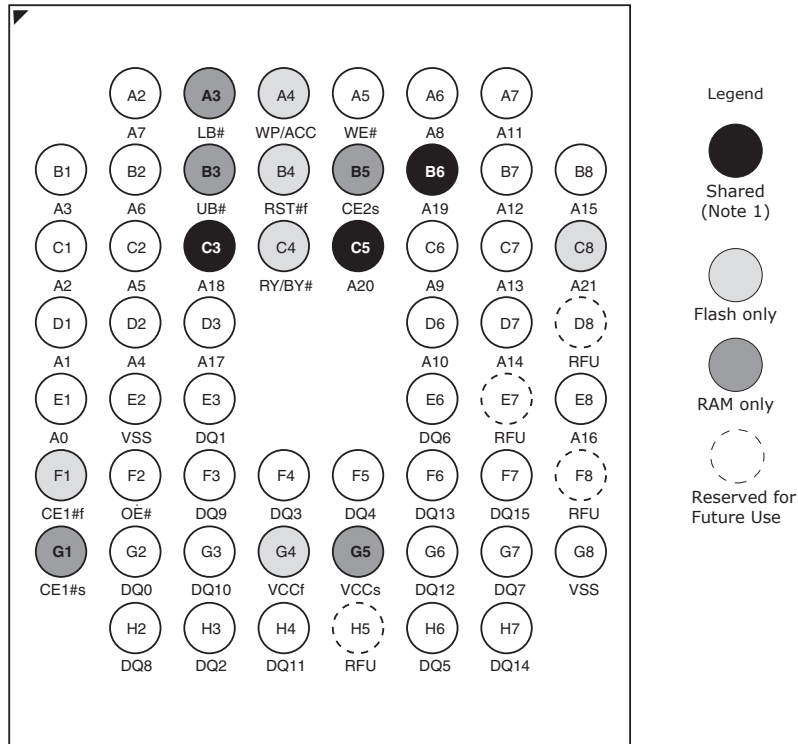

Notes:

1. May be shared depending on density.
 - A20 is shared for the 32M pSRAM configuration.
 - A19 is shared for the 16M pSRAM and above configurations.
 - A18 is shared for the 8M (p)SRAM and above configurations.
2. Connecting all Vcc and Vss balls to Vcc and Vss is recommended.

MCP	Flash-only Addresses	Shared Addresses
S71PL064JB0	A21	A20-A0
S71PL064JA0	A21-A20	A19-A0
S71PL064J80	A21-A19	A18-A0
S71PL064J08	A21-A19	A18-A0

Connection Diagram (S7IPL127J)

64-ball Fine-Pitch Ball Grid Array
(Top View, Balls Facing Down)

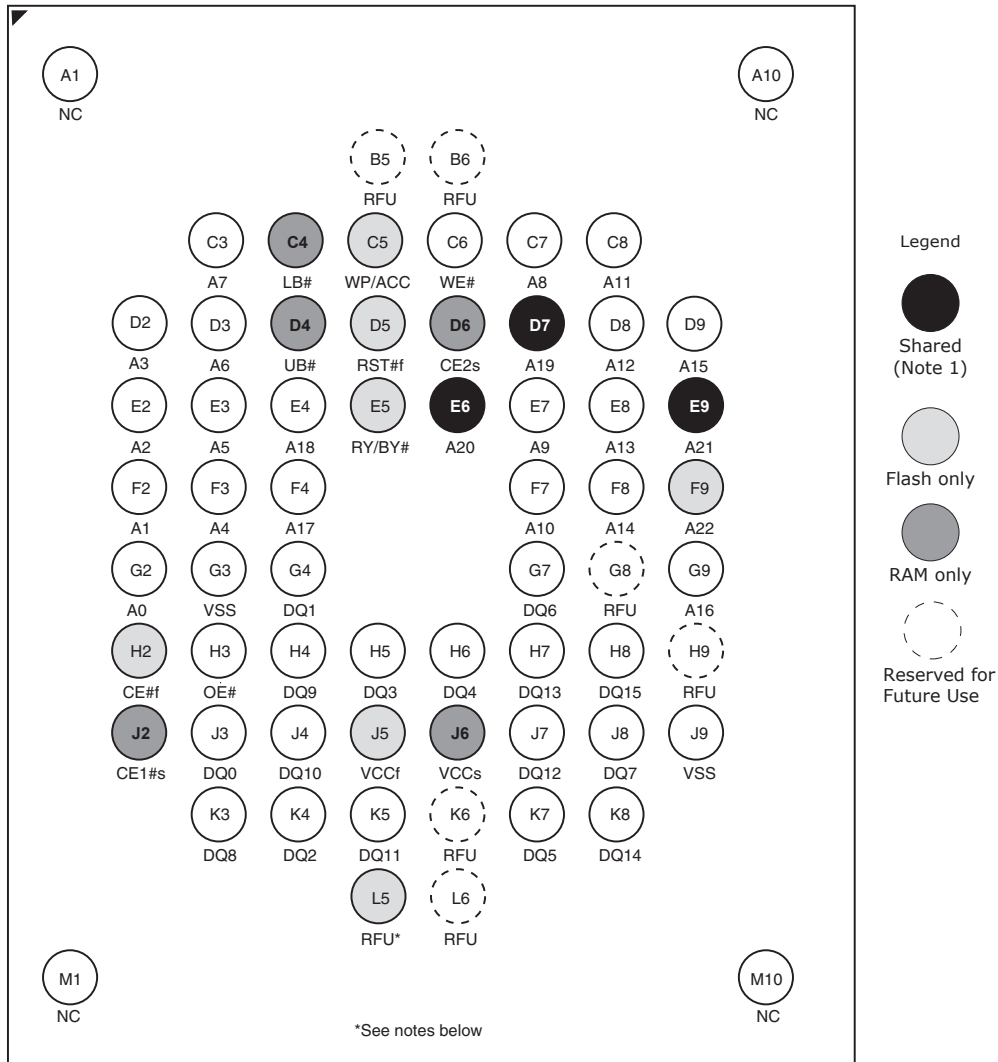

Notes:

- May be shared depending on density.
 - A21 is shared for the 64M pSRAM configuration.
 - A20 is shared for the 32M pSRAM and above configurations.
- A19 is shared for the 16M pSRAM and above configurations.

MCP	Flash-only Addresses	Shared Addresses
S71PL127JC0	A22	A21-A0
S71PL127JB0	A22-A21	A20-A0
S71PL127JA0	A22-A20	A19-A0

- Connecting all Vcc & Vss balls to Vcc & Vss is recommended.
- Ball L5 will be Vccf in the 84-ball density upgrades. Do not connect to Vss or any other signal.

Connection Diagram (S7IPL254J)

84-ball Fine-Pitch Ball Grid Array
(Top View, Balls Facing Down)

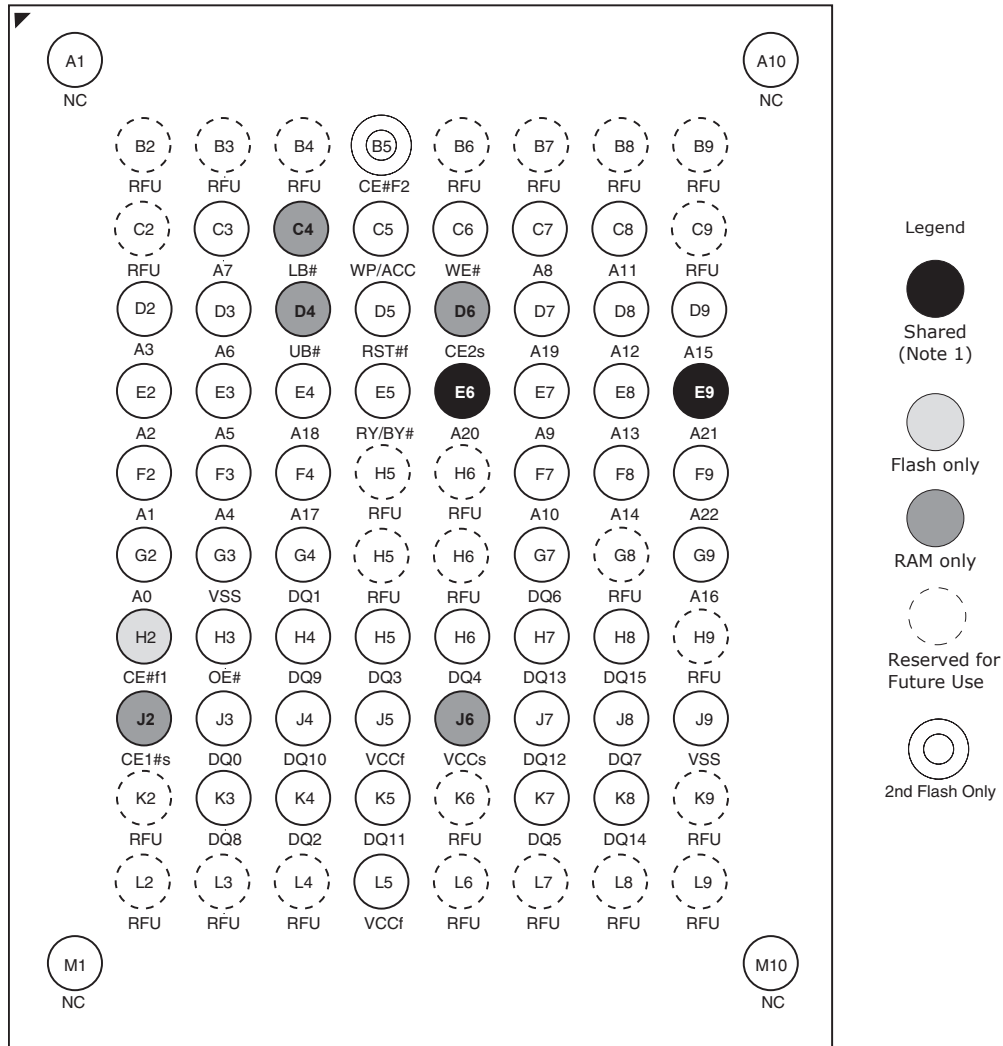

Notes:

1. May be shared depending on density.
 - A21 is shared for the 64M pSRAM configuration.
 - A20 is shared for the 32M pSRAM configuration.

MCP	Flash-only Addresses	Shared Addresses
S7IPL254JC0	A22	A21-A0
S7IPL254JB0	A22-A21	A20-A0

2. Connecting all Vcc & Vss balls to Vcc & Vss is recommended.

Special Handling Instructions For FBGA Package

Special handling is required for Flash Memory products in FBGA packages.

Flash memory devices in FBGA packages may be damaged if exposed to ultrasonic cleaning methods. The package and/or data integrity may be compromised

if the package body is exposed to temperatures above 150°C for prolonged periods of time.

Pin Description

A21-A0	=	22 Address Inputs (Common)
DQ15-DQ0	=	16 Data Inputs/Outputs (Common)
CE1#f	=	Chip Enable 1 (Flash)
CE#f2	=	Chip Enable 2 (Flash)
CE1#ps	=	Chip Enable 1 (pSRAM)
CE2ps	=	Chip Enable 2 (pSRAM)
OE#	=	Output Enable (Common)
WE#	=	Write Enable (Common)
RY/BY#	=	Ready/Busy Output (Flash 1)
UB#	=	Upper Byte Control (pSRAM)
LB#	=	Lower Byte Control (pSRAM)
RESET#	=	Hardware Reset Pin, Active Low (Flash 1)
WP#/ACC	=	Hardware Write Protect/Acceleration Pin (Flash)
V _{CC} ^f	=	Flash 3.0 volt-only single power supply (see Product Selector Guide for speed options and voltage supply tolerances)
V _{CC} ^{ps}	=	pSRAM Power Supply
V _{SS}	=	Device Ground (Common)
NC	=	Pin Not Connected Internally

Logic Symbol

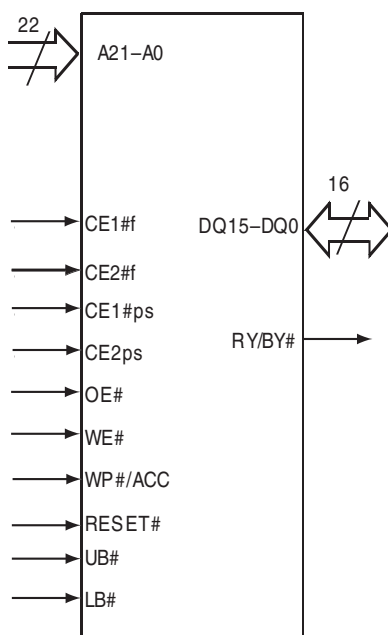

Ordering Information

The order number is formed by a valid combinations of the following:

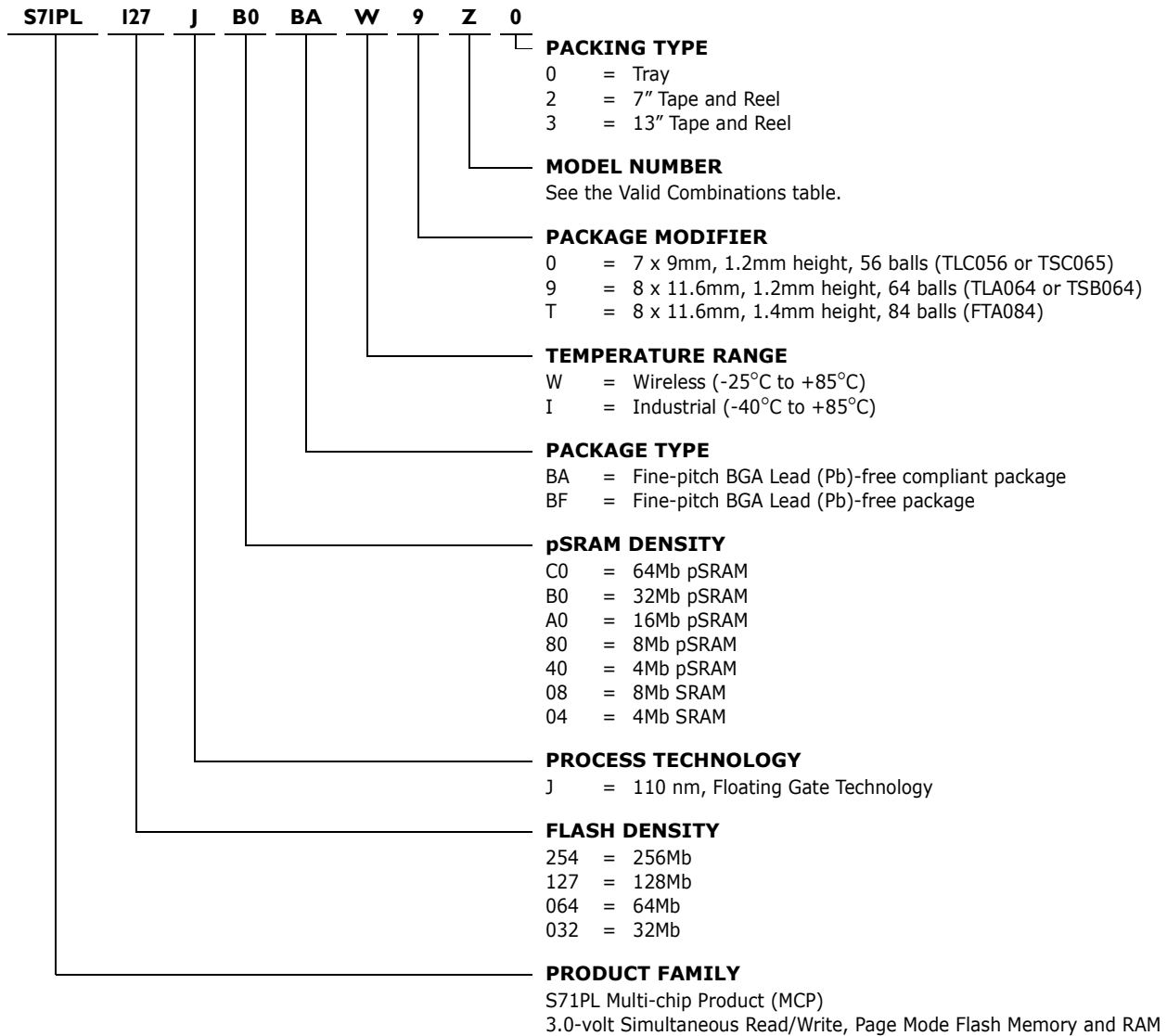

S71PL032J Valid Combinations				Speed Options (ns)	(p)SRAM Type/Access Time (ns)	Package Marking
Base Ordering Part Number	Package & Temperature	Package Modifier/ Model Number	Packing Type			
S71PL032J04	BAW	0B	0, 2, 3 (Note 1)	65	SRAM2 / 70	(Note 2)
S71PL032J04		0F			SRAM3 / 70	
S71PL032J04		0K			SRAM4 / 70	
S71PL032J40		0K			pSRAM4 / 70	
S71PL032J80		0P			pSRAM5 / 70	
S71PL032J08		0B			SRAM2 / 70	
S71PL032J40		07		pSRAM1 / 70		
S71PL032J80		07		pSRAM1 / 70		
S71PL032JA0		07		pSRAM1 / 70		
S71PL032JA0		0F		pSRAM3 / 70		
S71PL032JA0		0Z		pSRAM2 / 70		
S71PL032J04		BFW		0B	0, 2, 3 (Note 1)	
S71PL032J04	0F		SRAM3 / 70			
S71PL032J04	0K		SRAM4 / 70			
S71PL032J40	0K		pSRAM4 / 70			
S71PL032J80	0P		pSRAM5 / 70			
S71PL032J08	0B		SRAM2 / 70			
S71PL032J40	07		pSRAM1 / 70			
S71PL032J80	07		pSRAM1 / 70			
S71PL032JA0	07		pSRAM1 / 70			
S71PL032JA0	0F		pSRAM3 / 70			
S71PL032JA0	0Z		pSRAM2 / 70			
S71PL032J04	BAI		0B	0, 2, 3 (Note 1)		65
S71PL032J04		0F	SRAM3 / 70			
S71PL032J04		0K	SRAM4 / 70			
S71PL032J40		0K	pSRAM4 / 70			
S71PL032J80		0P	pSRAM5 / 70			
S71PL032J08		0B	SRAM2 / 70			
S71PL032J40		07	pSRAM1 / 70			
S71PL032J80		07	pSRAM1 / 70			
S71PL032JA0		07	pSRAM1 / 70			
S71PL032JA0		0F	pSRAM3 / 70			
S71PL032JA0		0Z	pSRAM2 / 70			
S71PL032J04		BFI	0B		0, 2, 3 (Note 1)	65
S71PL032J04	0F		SRAM3 / 70			
S71PL032J04	0K		SRAM4 / 70			
S71PL032J40	0K		pSRAM4 / 70			
S71PL032J80	0P		pSRAM5 / 70			
S71PL032J08	0B		SRAM2 / 70			
S71PL032J40	07		pSRAM1 / 70			
S71PL032J80	07		pSRAM1 / 70			
S71PL032JA0	07		pSRAM1 / 70			
S71PL032JA0	0F		pSRAM3 / 70			
S71PL032JA0	0Z		pSRAM2 / 70			

Notes:

1. Type 0 is standard. Specify other options as required.
2. BGA package marking omits leading "S" and packing type designator from ordering part number.

Valid Combinations

Valid Combinations list configurations planned to be supported in volume for this device. Consult your local sales office to confirm availability of specific valid combinations and to check on newly released combinations.

S71PL064J Valid Combinations				Speed Options (ns)	(p)SRAM Type/Access Time (ns)	Package Marking				
Base Ordering Part Number	Package & Temperature	Package Modifier/ Model Number	Packing Type							
S71PL064J08	BAW	0B	0, 2, 3 (Note 1)	65	SRAM1 / 70	(Note 2)				
S71PL064J08		0U			SRAM3 / 70					
S71PL064J80		0K			pSRAM1 / 70					
S71PL064J80		07			pSRAM1 / 70					
S71PL064J80		0P			pSRAM5 / 70					
S71PL064JA0		0Z			pSRAM7 / 70					
S71PL064JA0		0B			pSRAM3 / 70					
S71PL064JA0		07			pSRAM1 / 70					
S71PL064JA0		0P			pSRAM7 / 70					
S71PL064JB0		07			pSRAM1 / 70					
S71PL064JB0		0B			pSRAM2 / 70					
S71PL064JB0		0U			pSRAM6 / 70					
S71PL064J08		BFW			0B		0, 2, 3 (Note 1)	65	SRAM1 / 70	(Note 2)
S71PL064J08					0U				SRAM3 / 70	
S71PL064J80	0K		pSRAM1 / 70							
S71PL064J80	07		pSRAM1 / 70							
S71PL064J80	0P		pSRAM5 / 70							
S71PL064JA0	0Z		pSRAM7 / 70							
S71PL064JA0	0B		pSRAM3 / 70							
S71PL064JA0	07		pSRAM1 / 70							
S71PL064JA0	0P		pSRAM7 / 70							
S71PL064JB0	07		pSRAM1 / 70							
S71PL064JB0	0B		pSRAM2 / 70							
S71PL064JB0	0U		pSRAM6 / 70							
S71PL064J08	BAI		0B	0, 2, 3 (Note 1)	65	SRAM1 / 70			(Note 2)	
S71PL064J08			0U			SRAM3 / 70				
S71PL064J80		0K	pSRAM1 / 70							
S71PL064J80		07	pSRAM1 / 70							
S71PL064J80		0P	pSRAM5 / 70							
S71PL064JA0		0Z	pSRAM7 / 70							
S71PL064JA0		0B	pSRAM3 / 70							
S71PL064JA0		07	pSRAM1 / 70							
S71PL064JA0		0P	pSRAM7 / 70							
S71PL064JB0		07	pSRAM1 / 70							
S71PL064JB0		0B	pSRAM2 / 70							
S71PL064JB0		0U	pSRAM6 / 70							

S71PL064J Valid Combinations				Speed Options (ns)	(p)SRAM Type/Access Time (ns)	Package Marking
Base Ordering Part Number	Package & Temperature	Package Modifier/ Model Number	Packing Type			
S71PL064J08	BFI	0B	0, 2, 3 (Note 1)	65	SRAM1 / 70	(Note 2)
S71PL064J08		0U			SRAM3 / 70	
S71PL064J80		0K			pSRAM1 / 70	
S71PL064J80		07			pSRAM1 / 70	
S71PL064J80		0P			pSRAM5 / 70	
S71PL064JA0		0Z			pSRAM7 / 70	
S71PL064JA0		0B			pSRAM3 / 70	
S71PL064JA0		07			pSRAM1 / 70	
S71PL064JA0		0P			pSRAM7 / 70	
S71PL064JB0		07			pSRAM1 / 70	
S71PL064JB0		0B			pSRAM2 / 70	
S71PL064JB0		0U			pSRAM6 / 70	

Notes:

1. Type 0 is standard. Specify other options as required.
2. BGA package marking omits leading "S" and packing type designator from ordering part number.

Valid Combinations

Valid Combinations list configurations planned to be supported in volume for this device. Consult your local sales office to confirm availability of specific valid combinations and to check on newly released combinations.

S71PL127J Valid Combinations				Speed Options (ns)	(p)SRAM Type/Access Time (ns)	Package Marking				
Base Ordering Part Number	Package & Temperature	Package Modifier/ Model Number	Packing Type							
S71PL127JA0	BAW	9P	0, 2, 3 (Note 1)	65	pSRAM7 / 70	(Note 2)				
S71PL127JA0		9Z			pSRAM7 / 70					
S71PL127JA0		97			pSRAM1 / 70					
S71PL127JB0		97			pSRAM1 / 70					
S71PL127JB0		9Z			pSRAM7 / 70					
S71PL127JB0		9U			pSRAM6 / 70					
S71PL127JC0		97			pSRAM1 / 70					
S71PL127JC0		9Z			pSRAM7 / 70					
S71PL127JC0		9U			pSRAM6 / 70					
S71PL127JB0		9B			pSRAM2 / 70					
S71PL127JA0		BFW			9P		0, 2, 3 (Note 1)	65	pSRAM7 / 70	(Note 2)
S71PL127JA0					9Z				pSRAM7 / 70	
S71PL127JA0	97		pSRAM1 / 70							
S71PL127JB0	97		pSRAM1 / 70							
S71PL127JB0	9Z		pSRAM7 / 70							
S71PL127JB0	9U		pSRAM6 / 70							
S71PL127JC0	97		pSRAM1 / 70							
S71PL127JC0	9Z		pSRAM7 / 70							
S71PL127JC0	9U		pSRAM6 / 70							
S71PL127JB0	9B		pSRAM2 / 70							

S71PL127J Valid Combinations				Speed Options (ns)	(p)SRAM Type/Access Time (ns)	Package Marking				
Base Ordering Part Number	Package & Temperature	Package Modifier/Model Number	Packing Type							
S71PL127JA0	BAI	9P	0, 2, 3 (Note 1)	65	pSRAM7 / 70	(Note 2)				
S71PL127JA0		9Z			pSRAM7 / 70					
S71PL127JA0		97			pSRAM1 / 70					
S71PL127JB0		97			pSRAM1 / 70					
S71PL127JB0		9Z			pSRAM7 / 70					
S71PL127JB0		9U			pSRAM6 / 70					
S71PL127JC0		97			pSRAM1 / 70					
S71PL127JC0		9Z			pSRAM7 / 70					
S71PL127JC0		9U			pSRAM6 / 70					
S71PL127JB0		9B			pSRAM2 / 70					
S71PL127JA0		BFI			9P		0, 2, 3 (Note 1)	65	pSRAM7 / 70	(Note 2)
S71PL127JA0					9Z				pSRAM7 / 70	
S71PL127JA0	97		pSRAM1 / 70							
S71PL127JB0	97		pSRAM1 / 70							
S71PL127JB0	9Z		pSRAM7 / 70							
S71PL127JB0	9U		pSRAM6 / 70							
S71PL127JB0	9B		pSRAM2 / 70							
S71PL127JC0	97		pSRAM1 / 70							
S71PL127JC0	9Z		pSRAM7 / 70							
S71PL127JC0	9U		pSRAM6 / 70							

Notes:

1. Type 0 is standard. Specify other options as required.
2. BGA package marking omits leading "S" and packing type designator from ordering part number.

Valid Combinations

Valid Combinations list configurations planned to be supported in volume for this device. Consult your local sales office to confirm availability of specific valid combinations and to check on newly released combinations.

S71PL254J Valid Combinations				Speed Options (ns)	(p)SRAM Type/Access Time (ns)	Package Marking
Base Ordering Part Number	Package & Temperature	Model Number	Packing Type			
S71PL254JB0	BAW	T7	0, 2, 3 (Note 1)	65	pSRAM1 / 70	(Note 2)
S71PL254JB0		TB			pSRAM2 / 70	
S71PL254JB0		TU			pSRAM6 / 70	
S71PL254JC0		TB			pSRAM2 / 70	
S71PL254JC0		TZ			pSRAM7 / 70	
S71PL254JB0	BFW	T7	0, 2, 3 (Note 1)	65	pSRAM1 / 70	(Note 2)
S71PL254JB0		TB			pSRAM2 / 70	
S71PL254JB0		TU			pSRAM6 / 70	
S71PL254JC0		TB			pSRAM2 / 70	
S71PL254JC0		TZ			pSRAM7 / 70	
S71PL254JB0	BAI	T7	0, 2, 3 (Note 1)	65	pSRAM1 / 70	(Note 2)
S71PL254JB0		TB			pSRAM2 / 70	
S71PL254JB0		TU			pSRAM6 / 70	
S71PL254JC0		TB			pSRAM2 / 70	
S71PL254JC0		TZ			pSRAM7 / 70	
S71PL254JB0	BFI	T7	0, 2, 3 (Note 1)	65	pSRAM1 / 70	(Note 2)
S71PL254JB0		TB			pSRAM2 / 70	
S71PL254JB0		TU			pSRAM6 / 70	
S71PL254JC0		TB			pSRAM2 / 70	
S71PL254JC0		TZ			pSRAM7 / 70	

Notes:

1. Type 0 is standard. Specify other options as required.
2. BGA package marking omits leading "S" and packing type designator from ordering part number.

Valid Combinations

Valid Combinations list configurations planned to be supported in volume for this device. Consult your local sales office to confirm availability of specific valid combinations and to check on newly released combinations.

Physical Dimensions

TLC056—56-ball Fine-Pitch Ball Grid Array (FBGA) 9 x 7mm Package

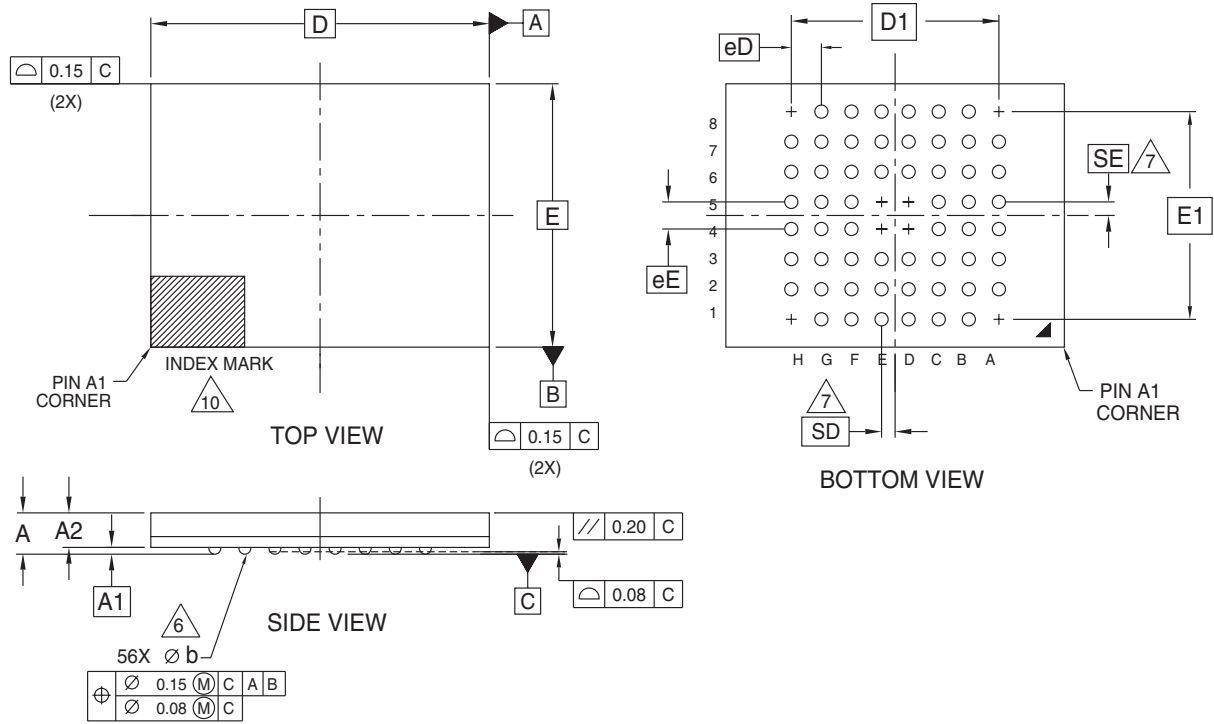

PACKAGE	TLC 056			NOTE
JEDEC	N/A			
D x E	9.00 mm x 7.00 mm PACKAGE			
SYMBOL	MIN	NOM	MAX	
A	---	---	1.20	PROFILE
A1	0.20	---	---	BALL HEIGHT
A2	0.81	---	0.97	BODY THICKNESS
D	9.00 BSC.			BODY SIZE
E	7.00 BSC.			BODY SIZE
D1	5.60 BSC.			MATRIX FOOTPRINT
E1	5.60 BSC.			MATRIX FOOTPRINT
MD	8			MATRIX SIZE D DIRECTION
ME	8			MATRIX SIZE E DIRECTION
n	56			BALL COUNT
phi b	0.35	0.40	0.45	BALL DIAMETER
eE	0.80 BSC.			BALL PITCH
eD	0.80 BSC.			BALL PITCH
SD / SE	0.40 BSC.			SOLDER BALL PLACEMENT
	A1,A8,D4,D5,E4,E5,H1,H8			DEPOPULATED SOLDER BALLS

NOTES:

- DIMENSIONING AND TOLERANCING METHODS PER ASME Y14.5M-1994.
- ALL DIMENSIONS ARE IN MILLIMETERS.
- BALL POSITION DESIGNATION PER JESD 95-1, SPP-010.
- [e] REPRESENTS THE SOLDER BALL GRID PITCH.
- SYMBOL "MD" IS THE BALL MATRIX SIZE IN THE "D" DIRECTION.
SYMBOL "ME" IS THE BALL MATRIX SIZE IN THE "E" DIRECTION.
n IS THE NUMBER OF POPULATED SOLDER BALL POSITIONS FOR MATRIX SIZE MD X ME.
- DIMENSION "b" IS MEASURED AT THE MAXIMUM BALL DIAMETER IN A PLANE PARALLEL TO DATUM C.
- SD AND SE ARE MEASURED WITH RESPECT TO DATUMS A AND B AND DEFINE THE POSITION OF THE CENTER SOLDER BALL IN THE OUTER ROW.
WHEN THERE IS AN ODD NUMBER OF SOLDER BALLS IN THE OUTER ROW SD OR SE = 0.000.
WHEN THERE IS AN EVEN NUMBER OF SOLDER BALLS IN THE OUTER ROW, SD OR SE = [e/2]
- "+" INDICATES THE THEORETICAL CENTER OF DEPOPULATED BALLS.
- N/A
- A1 CORNER TO BE IDENTIFIED BY CHAMFER, LASER OR INK MARK, METALLIZED MARK INDENTATION OR OTHER MEANS.

3348 \ 16-038.22a

TSC056—56-ball Fine-Pitch Ball Grid Array (FBGA) 9 x 7mm Package

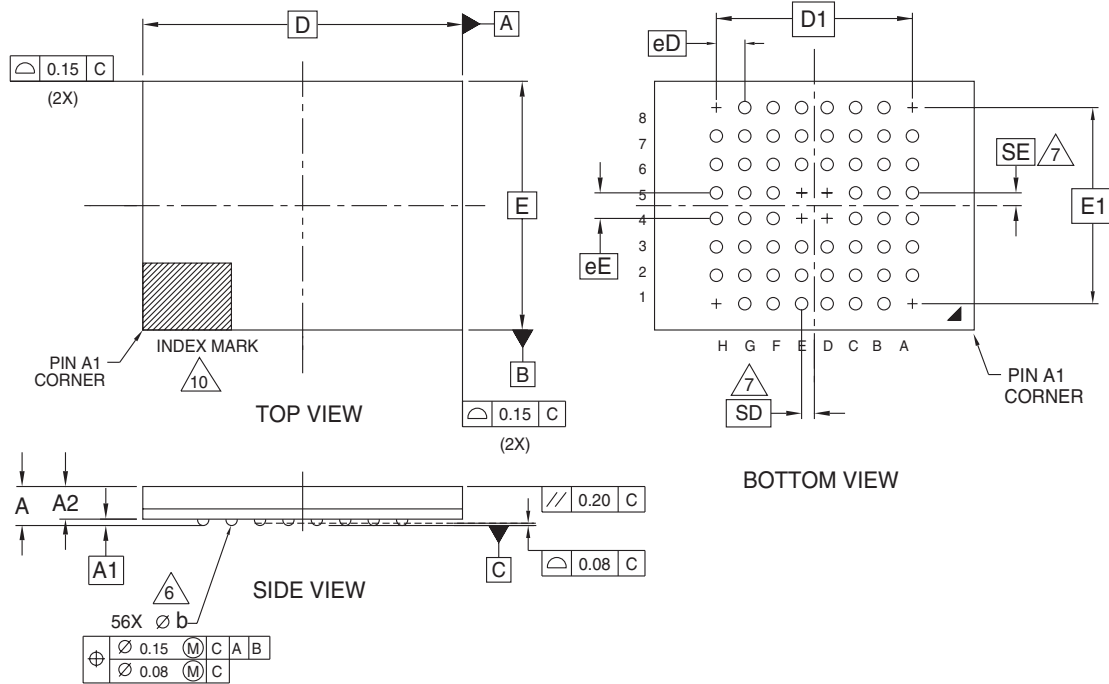

PACKAGE	TSC 056			
JEDEC	N/A			
D x E	9.00 mm x 7.00 mm PACKAGE			
SYMBOL	MIN	NOM	MAX	NOTE
A	---	---	1.20	PROFILE
A1	0.17	---	---	BALL HEIGHT
A2	0.81	---	0.97	BODY THICKNESS
D	9.00 BSC.			BODY SIZE
E	7.00 BSC.			BODY SIZE
D1	5.60 BSC.			MATRIX FOOTPRINT
E1	5.60 BSC.			MATRIX FOOTPRINT
MD	8			MATRIX SIZE D DIRECTION
ME	8			MATRIX SIZE E DIRECTION
n	56			BALL COUNT
ϕ b	0.35	0.40	0.45	BALL DIAMETER
eE	0.80 BSC.			BALL PITCH
eD	0.80 BSC.			BALL PITCH
SD / SE	0.40 BSC.			SOLDER BALL PLACEMENT
	A1,A8,D4,D5,E4,E5,H1,H8			DEPOPULATED SOLDER BALLS

NOTES:

- DIMENSIONING AND TOLERANCING METHODS PER ASME Y14.5M-1994.
- ALL DIMENSIONS ARE IN MILLIMETERS.
- BALL POSITION DESIGNATION PER JESD 95-1, SPP-010.
- [e] REPRESENTS THE SOLDER BALL GRID PITCH.
- SYMBOL "MD" IS THE BALL MATRIX SIZE IN THE "D" DIRECTION.
SYMBOL "ME" IS THE BALL MATRIX SIZE IN THE "E" DIRECTION.
n IS THE NUMBER OF POPULATED SOLDER BALL POSITIONS FOR MATRIX SIZE MD X ME.
- DIMENSION "b" IS MEASURED AT THE MAXIMUM BALL DIAMETER IN A PLANE PARALLEL TO DATUM C.
- SD AND SE ARE MEASURED WITH RESPECT TO DATUMS A AND B AND DEFINE THE POSITION OF THE CENTER SOLDER BALL IN THE OUTER ROW.
WHEN THERE IS AN ODD NUMBER OF SOLDER BALLS IN THE OUTER ROW SD OR SE = 0.000.
WHEN THERE IS AN EVEN NUMBER OF SOLDER BALLS IN THE OUTER ROW, SD OR SE = [e/2]
- "+" INDICATES THE THEORETICAL CENTER OF DEPOPULATED BALLS.
- N/A
- A1 CORNER TO BE IDENTIFIED BY CHAMFER, LASER OR INK MARK, METALLIZED MARK INDENTATION OR OTHER MEANS.

3427 \ 16-038.22

TLA064—64-ball Fine-Pitch Ball Grid Array (FBGA) 8 x 11.6mm Package

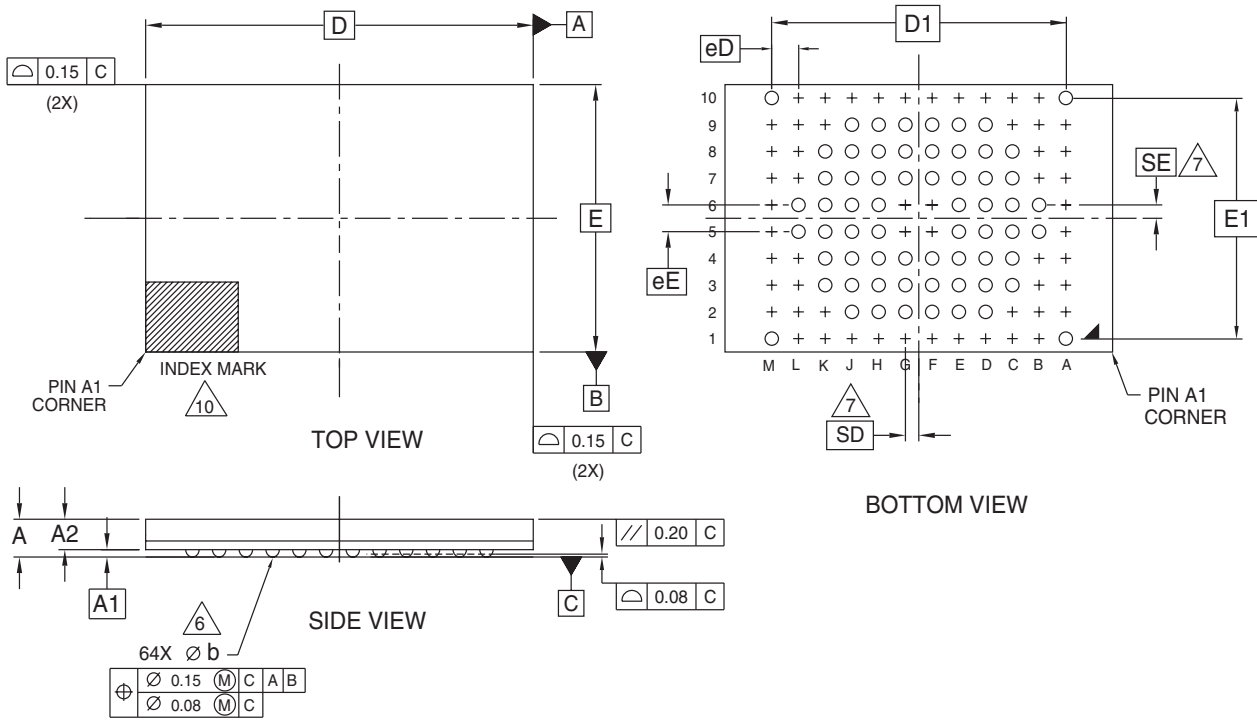

PACKAGE	TLA 064			
JEDEC	N/A			
D x E	11.60 mm x 8.00 mm PACKAGE			
SYMBOL	MIN	NOM	MAX	NOTE
A	---	---	1.20	PROFILE
A1	0.17	---	---	BALL HEIGHT
A2	0.81	---	0.97	BODY THICKNESS
D	11.60 BSC.			BODY SIZE
E	8.00 BSC.			BODY SIZE
D1	8.80 BSC.			MATRIX FOOTPRINT
E1	7.20 BSC.			MATRIX FOOTPRINT
MD	12			MATRIX SIZE D DIRECTION
ME	10			MATRIX SIZE E DIRECTION
n	64			BALL COUNT
ϕ b	0.35	0.40	0.45	BALL DIAMETER
eE	0.80 BSC.			BALL PITCH
eD	0.80 BSC.			BALL PITCH
SD / SE	0.40 BSC.			SOLDER BALL PLACEMENT
	A2,A3,A4,A5,A6,A7,A8,A9 B1,B2,B3,B4,B7,B8,B9,B10 C1,C2,C9,C10,D1,D10,E1,E10, F1,F5,F6,F10,G1,G5,G6,G10 H1,H10,J1,J10,K1,K2,K9,K10 L1,L2,L3,L4,L7,L8,L9,L10 M2,M3,M4,M5,M6,M7,M8,M9			DEPOPULATED SOLDER BALLS

NOTES:

- DIMENSIONING AND TOLERANCING METHODS PER ASME Y14.5M-1994.
- ALL DIMENSIONS ARE IN MILLIMETERS.
- BALL POSITION DESIGNATION PER JESD 95-1, SPP-010.
- \square REPRESENTS THE SOLDER BALL GRID PITCH.
- SYMBOL "MD" IS THE BALL MATRIX SIZE IN THE "D" DIRECTION.

SYMBOL "ME" IS THE BALL MATRIX SIZE IN THE "E" DIRECTION.

n IS THE NUMBER OF POPULATED SOLDER BALL POSITIONS FOR MATRIX SIZE MD X ME.

\triangle 6 DIMENSION "b" IS MEASURED AT THE MAXIMUM BALL DIAMETER IN A PLANE PARALLEL TO DATUM C.

\triangle 7 SD AND SE ARE MEASURED WITH RESPECT TO DATUMS A AND B AND DEFINE THE POSITION OF THE CENTER SOLDER BALL IN THE OUTER ROW.

WHEN THERE IS AN ODD NUMBER OF SOLDER BALLS IN THE OUTER ROW SD OR SE = 0.000.

WHEN THERE IS AN EVEN NUMBER OF SOLDER BALLS IN THE OUTER ROW, SD OR SE = $\square/2$

- "+" INDICATES THE THEORETICAL CENTER OF DEPOPULATED BALLS.
- N/A

\triangle 10 A1 CORNER TO BE IDENTIFIED BY CHAMFER, LASER OR INK MARK, METALLIZED MARK INDENTATION OR OTHER MEANS.

TSB064—64-ball Fine-Pitch Ball Grid Array (FBGA) 8 x 11.6 mm Package

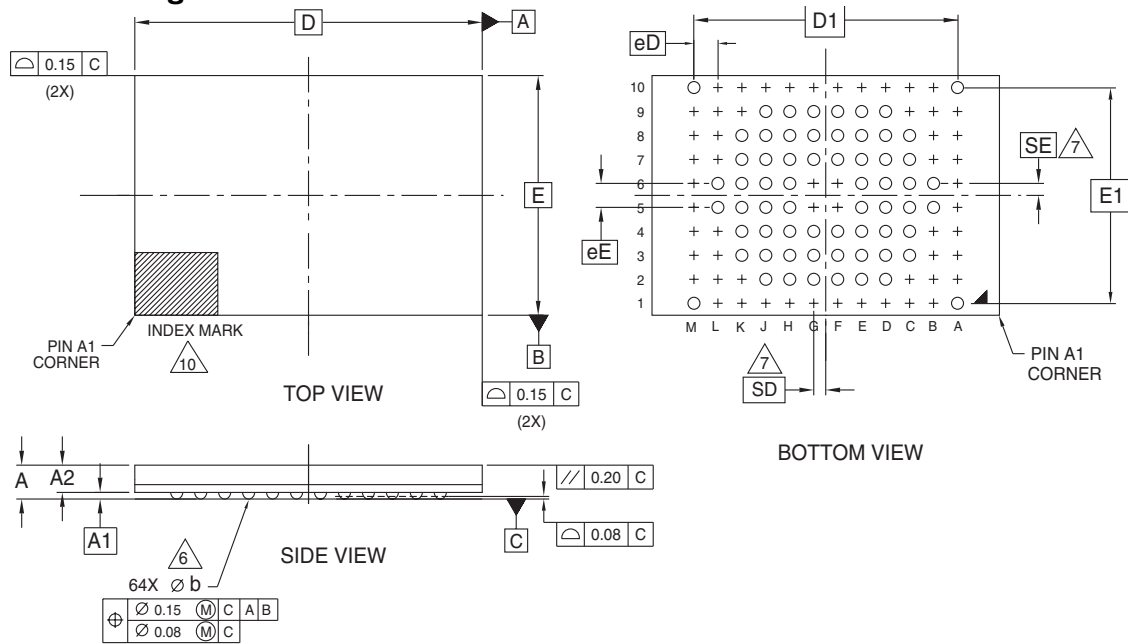

PACKAGE	TSB 064			NOTE
JEDEC	N/A			
D x E	11.60 mm x 8.00 mm PACKAGE			
SYMBOL	MIN	NOM	MAX	
A	---	---	1.20	PROFILE
A1	017	---	---	BALL HEIGHT
A2	0.81	---	0.97	BODY THICKNESS
D	11.60 BSC.			BODY SIZE
E	8.00 BSC.			BODY SIZE
D1	8.80 BSC.			MATRIX FOOTPRINT
E1	7.20 BSC.			MATRIX FOOTPRINT
MD	12			MATRIX SIZE D DIRECTION
ME	10			MATRIX SIZE E DIRECTION
n	64			BALL COUNT
ϕb	0.35	0.40	0.45	BALL DIAMETER
eE	0.80 BSC.			BALL PITCH
eD	0.80 BSC.			BALL PITCH
SD / SE	0.40 BSC.			SOLDER BALL PLACEMENT
	A2,A3,A4,A5,A6,A7,A8,A9 B1,B2,B3,B4,B7,B8,B9,B10 C1,C2,C9,C10,D1,D10,E1,E10 F1,F5,F6,F10,G1,G5,G6,G10 H1,H10,J1,J10,K1,K2,K9,K10 L1,L2,L3,L4,L7,L8,L9,L10 M2,M3,M4,M5,M6,M7,M8,M9			DEPOPULATED SOLDER BALLS

NOTES:

- DIMENSIONING AND TOLERANCING METHODS PER ASME Y14.5M-1994.
- ALL DIMENSIONS ARE IN MILLIMETERS.
- BALL POSITION DESIGNATION PER JESD 95-1, SPP-010.
- e REPRESENTS THE SOLDER BALL GRID PITCH.
- SYMBOL "MD" IS THE BALL MATRIX SIZE IN THE "D" DIRECTION.
SYMBOL "ME" IS THE BALL MATRIX SIZE IN THE "E" DIRECTION.
n IS THE NUMBER OF POPULATED SOLDER BALL POSITIONS FOR MATRIX SIZE MD X ME.
- DIMENSION "b" IS MEASURED AT THE MAXIMUM BALL DIAMETER IN A PLANE PARALLEL TO DATUM C.
- SD AND SE ARE MEASURED WITH RESPECT TO DATUMS A AND B AND DEFINE THE POSITION OF THE CENTER SOLDER BALL IN THE OUTER ROW.
WHEN THERE IS AN ODD NUMBER OF SOLDER BALLS IN THE OUTER ROW SD OR SE = 0.000.
WHEN THERE IS AN EVEN NUMBER OF SOLDER BALLS IN THE OUTER ROW, SD OR SE = $e/2$
- "+" INDICATES THE THEORETICAL CENTER OF DEPOPULATED BALLS.
- N/A
- A1 CORNER TO BE IDENTIFIED BY CHAMFER, LASER OR INK MARK, METALLIZED MARK INDENTATION OR OTHER MEANS.

3351 \ 16-038.22a

FTA084—84-ball Fine-Pitch Ball Grid Array (FBGA) 8 x 11.6mm

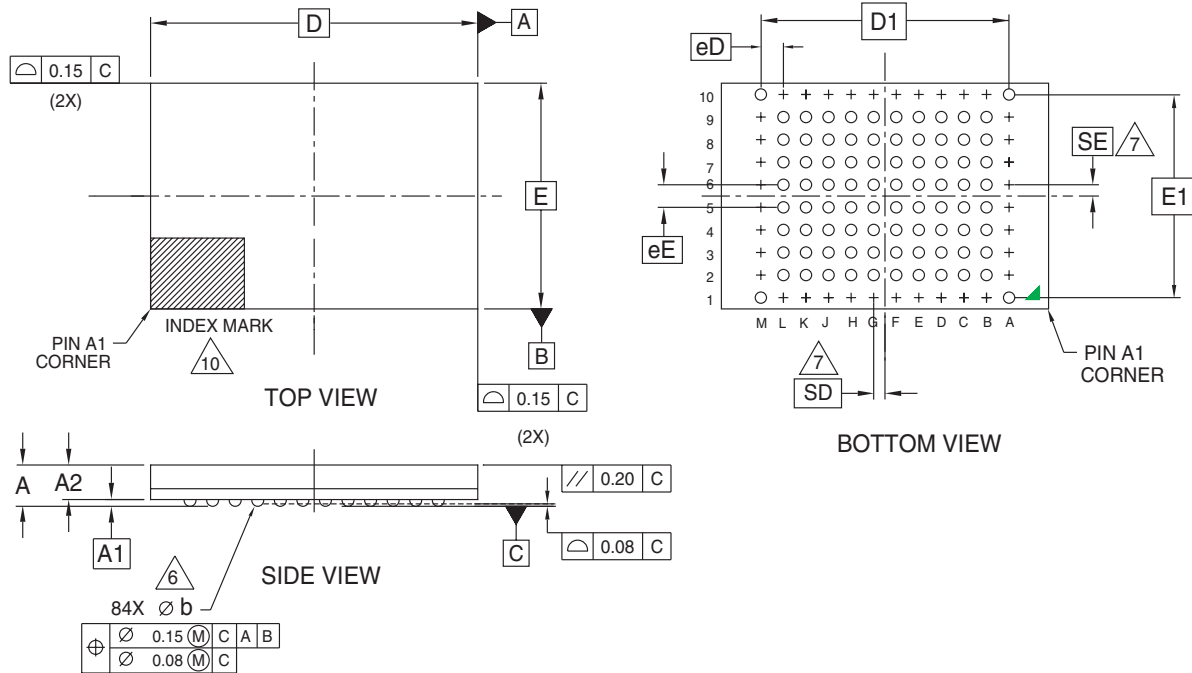

PACKAGE	FTA 084			NOTE
JEDEC	N/A			
D x E	11.60 mm x 8.00 mm PACKAGE			
SYMBOL	MIN	NOM	MAX	
A	---	---	1.40	PROFILE
A1	0.17	---	---	BALL HEIGHT
A2	1.02	---	1.17	BODY THICKNESS
D	11.60 BSC.			BODY SIZE
E	8.00 BSC.			BODY SIZE
D1	8.80 BSC.			MATRIX FOOTPRINT
E1	7.20 BSC.			MATRIX FOOTPRINT
MD	12			MATRIX SIZE D DIRECTION
ME	10			MATRIX SIZE E DIRECTION
n	84			BALL COUNT
φb	0.35	0.40	0.45	BALL DIAMETER
eE	0.80 BSC.			BALL PITCH
eD	0.80 BSC.			BALL PITCH
SD / SE	0.40 BSC.			SOLDER BALL PLACEMENT
	A2,A3,A4,A5,A6,A7,A8,A9 B1,B10,C1,C10,D1,D10,E1,E10 F1,F10,G1,G10,H1,H10 J1,J10,K1,K10,L1,L10 M2,M3,M4,M5,M6,M7,M8,M9			DEPOPULATED SOLDER BALLS

NOTES:

- DIMENSIONING AND TOLERANCING METHODS PER ASME Y14.5M-1994.
- ALL DIMENSIONS ARE IN MILLIMETERS.
- BALL POSITION DESIGNATION PER JESD 95-1, SPP-010.
- [e] REPRESENTS THE SOLDER BALL GRID PITCH.
- SYMBOL "MD" IS THE BALL MATRIX SIZE IN THE "D" DIRECTION.
SYMBOL "ME" IS THE BALL MATRIX SIZE IN THE "E" DIRECTION.
n IS THE NUMBER OF POPULATED SOLDER BALL POSITIONS FOR MATRIX SIZE MD X ME.
- DIMENSION "b" IS MEASURED AT THE MAXIMUM BALL DIAMETER IN A PLANE PARALLEL TO DATUM C.
- SD AND SE ARE MEASURED WITH RESPECT TO DATUMS A AND B AND DEFINE THE POSITION OF THE CENTER SOLDER BALL IN THE OUTER ROW.
WHEN THERE IS AN ODD NUMBER OF SOLDER BALLS IN THE OUTER ROW SD OR SE = 0.000.
WHEN THERE IS AN EVEN NUMBER OF SOLDER BALLS IN THE OUTER ROW, SD OR SE = $\frac{e}{2}$
- "+" INDICATES THE THEORETICAL CENTER OF DEPOPULATED BALLS.
- N/A
- A1 CORNER TO BE IDENTIFIED BY CHAMFER, LASER OR INK MARK, METALLIZED MARK INDENTATION OR OTHER MEANS.

3388 \ 16-038.21a

S29PL127J/S29PL064J/S29PL032J for MCP

128/64/32 Megabit (8/4/2 M x 16-Bit)

CMOS 3.0 Volt-only, Simultaneous Read/Write

Flash Memory with Enhanced VersatileIO™ Control



ADVANCE
INFORMATION

Distinctive Characteristics

Architectural Advantages

- **128/64/32 Mbit Page Mode devices**
 - Page size of 8 words: Fast page read access from random locations within the page
- **Single power supply operation**
 - Full Voltage range: 2.7 to 3.1 volt read, erase, and program operations for battery-powered applications
- **Simultaneous Read/Write Operation**
 - Data can be continuously read from one bank while executing erase/program functions in another bank
 - Zero latency switching from write to read operations
- **FlexBank Architecture (PL127J/PL064J/PL032J)**
 - 4 separate banks, with up to two simultaneous operations per device
 - Bank A:
 - PL127J - 16 Mbit (4 Kw x 8 and 32 Kw x 31)
 - PL064J - 8 Mbit (4 Kw x 8 and 32 Kw x 15)
 - PL032J - 4 Mbit (4 Kw x 8 and 32 Kw x 7)
 - Bank B:
 - PL127J - 48 Mbit (32 Kw x 96)
 - PL064J - 24 Mbit (32 Kw x 48)
 - PL032J - 12 Mbit (32 Kw x 24)
 - Bank C:
 - PL127J - 48 Mbit (32 Kw x 96)
 - PL064J - 24 Mbit (32 Kw x 48)
 - PL032J - 12 Mbit (32 Kw x 24)
 - Bank D:
 - PL127J - 16 Mbit (4 Kw x 8 and 32 Kw x 31)
 - PL064J - 8 Mbit (4 Kw x 8 and 32 Kw x 15)
 - PL032J - 4 Mbit (4 Kw x 8 and 32 Kw x 7)
- **Enhanced VersatileI/O™ (V_{IO}) Control**
 - Output voltage generated and input voltages tolerated on all control inputs and I/Os is determined by the voltage on the V_{IO} pin
 - V_{IO} options at 1.8 V and 3 V I/O for PL127J devices
 - 3V V_{IO} for PL064J and PL032J devices

- **Secured Silicon Sector region**
 - Up to 128 words accessible through a command sequence
 - Up to 64 factory-locked words
 - Up to 64 customer-lockable words
- **Both top and bottom boot blocks in one device**
- **Manufactured on 110 nm process technology**
- **Data Retention: 20 years typical**
- **Cycling Endurance: 1 million cycles per sector typical**

Performance Characteristics

- **High Performance**
 - Page access times as fast as 20 ns
 - Random access times as fast as 55 ns
- **Power consumption (typical values at 10 MHz)**
 - 45 mA active read current
 - 17 mA program/erase current
 - 0.2 µA typical standby mode current

Software Features

- **Software command-set compatible with JEDEC 42.4 standard**
 - Backward compatible with Am29F, Am29LV, Am29DL, and AM29PDL families and MBM29QM/RM, MBM29LV, MBM29DL, MBM29PDL families
- **CFI (Common Flash Interface) compliant**
 - Provides device-specific information to the system, allowing host software to easily reconfigure for different Flash devices
- **Erase Suspend / Erase Resume**
 - Suspends an erase operation to allow read or program operations in other sectors of same bank
- **Unlock Bypass Program command**
 - Reduces overall programming time when issuing multiple program command sequences

Hardware Features

■ Ready/Busy# pin (RY/BY#)

- Provides a hardware method of detecting program or erase cycle completion

■ Hardware reset pin (RESET#)

- Hardware method to reset the device to reading array data

■ WP#/ ACC (Write Protect/Acceleration) input

- At V_{IL} , hardware level protection for the first and last two 4K word sectors.
- At V_{IH} , allows removal of sector protection
- At V_{HH} , provides accelerated programming in a factory setting

■ Persistent Sector Protection

- A command sector protection method to lock combinations of individual sectors and sector groups

to prevent program or erase operations within that sector

- Sectors can be locked and unlocked in-system at V_{CC} level

■ Password Sector Protection

- A sophisticated sector protection method to lock combinations of individual sectors and sector groups to prevent program or erase operations within that sector using a user-defined 64-bit password

■ Package options

- Standard discrete pinouts
 - 11 x 8 mm, 80-ball Fine-pitch BGA (PL127J) (VBG080)
 - 8 x 6 mm, 48-ball Fine pitch BGA (PL064J/PL032J) (VBK048)
- MCP-compatible pinout
 - 8 x 11.6 mm, 64-ball Fine-pitch BGA (PL127J) 7 x 9 mm, 56-ball Fine-pitch BGA (PL064J and PL032J) Compatible with MCP pinout, allowing easy integration of RAM into existing designs

General Description

The PL127J/PL064J/PL032J is a 128/128/64/32 Mbit, 3.0 volt-only Page Mode and Simultaneous Read/Write Flash memory device organized as 8/8/4/2 Mwords. The devices are offered in the following packages:

- 11mm x 8mm, 64-ball Fine-pitch BGA standalone (all)
- 9mm x 8mm, 80-ball Fine-pitch BGA standalone (PL127J)
- 8mm x 11.6mm, 64-ball Fine pitch BGA multi-chip compatible (PL127J)

The word-wide data (x16) appears on DQ15-DQ0. This device can be programmed in-system or in standard EPROM programmers. A 12.0 V V_{pp} is not required for write or erase operations.

The device offers fast page access times of 20 to 30 ns, with corresponding random access times of 55 to 70 ns, respectively, allowing high speed microprocessors to operate without wait states. To eliminate bus contention the device has separate chip enable (CE#), write enable (WE#) and output enable (OE#) controls.

Simultaneous Read/Write Operation with Zero Latency

The Simultaneous Read/Write architecture provides **simultaneous operation** by dividing the memory space into 4 banks, which can be considered to be four separate memory arrays as far as certain operations are concerned. The device can improve overall system performance by allowing a host system to program or erase in one bank, then immediately and simultaneously read from another bank with zero latency (with two simultaneous operations operating at any one time). This releases the system from waiting for the completion of a program or erase operation, greatly improving system performance.

The device can be organized in both top and bottom sector configurations. The banks are organized as follows:

Bank	PL127J Sectors	PL064J Sectors	PL032J Sectors
A	16 Mbit (4 Kw x 8 and 32 Kw x 31)	8 Mbit (4 Kw x 8 and 32 Kw x 15)	4 Mbit (4 Kw x 8 and 32 Kw x 7)
B	48 Mbit (32 Kw x 96)	24 Mbit (32 Kw x 48)	12 Mbit (32 Kw x 24)
C	48 Mbit (32 Kw x 96)	24 Mbit (32 Kw x 48)	12 Mbit (32 Kw x 24)
D	16 Mbit (4 Kw x 8 and 32 Kw x 31)	8 Mbit (4 Kw x 8 and 32 Kw x 15)	4 Mbit (4 Kw x 8 and 32 Kw x 7)

Page Mode Features

The page size is 8 words. After initial page access is accomplished, the page mode operation provides fast read access speed of random locations within that page.

Standard Flash Memory Features

The device requires a **single 3.0 volt power supply** (2.7 V to 3.6 V) for both read and write functions. Internally generated and regulated voltages are provided for the program and erase operations.

The device is entirely command set compatible with the **JEDEC 42.4 single-power-supply Flash standard**. Commands are written to the command register using standard microprocessor write timing. Register contents serve as inputs to an internal state-machine that controls the erase and programming circuitry. Write cycles also internally latch addresses and data needed for the programming

and erase operations. Reading data out of the device is similar to reading from other Flash or EPROM devices.

Device programming occurs by executing the program command sequence. The Unlock Bypass mode facilitates faster programming times by requiring only two write cycles to program data instead of four. Device erasure occurs by executing the erase command sequence.

The host system can detect whether a program or erase operation is complete by reading the DQ7 (Data# Polling) and DQ6 (toggle) **status bits**. After a program or erase cycle has been completed, the device is ready to read array data or accept another command.

The sector erase architecture allows memory sectors to be erased and reprogrammed without affecting the data contents of other sectors. The device is fully erased when shipped from the factory.

Hardware data protection measures include a low V_{CC} detector that automatically inhibits write operations during power transitions. The hardware sector protection feature disables both program and erase operations in any combination of sectors of memory. This can be achieved in-system or via programming equipment.

The Erase Suspend/Erase Resume feature enables the user to put erase on hold for any period of time to read data from, or program data to, any sector that is not selected for erasure. True background erase can thus be achieved. If a read is needed from the Secured Silicon Sector area (One Time Program area) after an erase suspend, then the user must use the proper command sequence to enter and exit this region.

The device offers two power-saving features. When addresses have been stable for a specified amount of time, the device enters the **automatic sleep mode**. The system can also place the device into the standby mode. Power consumption is greatly reduced in both these modes.

The device electrically erases all bits within a sector simultaneously via Fowler-Nordheim tunneling. The data is programmed using hot electron injection.

Product Selector Guide

Part Number		S29PL032J/S29PL064J/S29PL127J				
Speed Option	$V_{CC}, V_{IO} = 2.7-3.6\text{ V}$	55 (Note)	60			70
	$V_{CC} = 2.7-3.6\text{ V},$ $V_{IO} = 1.65-1.95\text{ V (PL127J only)}$			65	70	
Max Access Time, ns (t_{ACC})		55 (Note)	60	65	70	70
Max CE# Access, ns (t_{CE})						
Max Page Access, ns (t_{PACC})		20 (Note)	25	30	30	30
Max OE# Access, ns (t_{OE})						

Note: Contact factory for availability.

Block Diagram

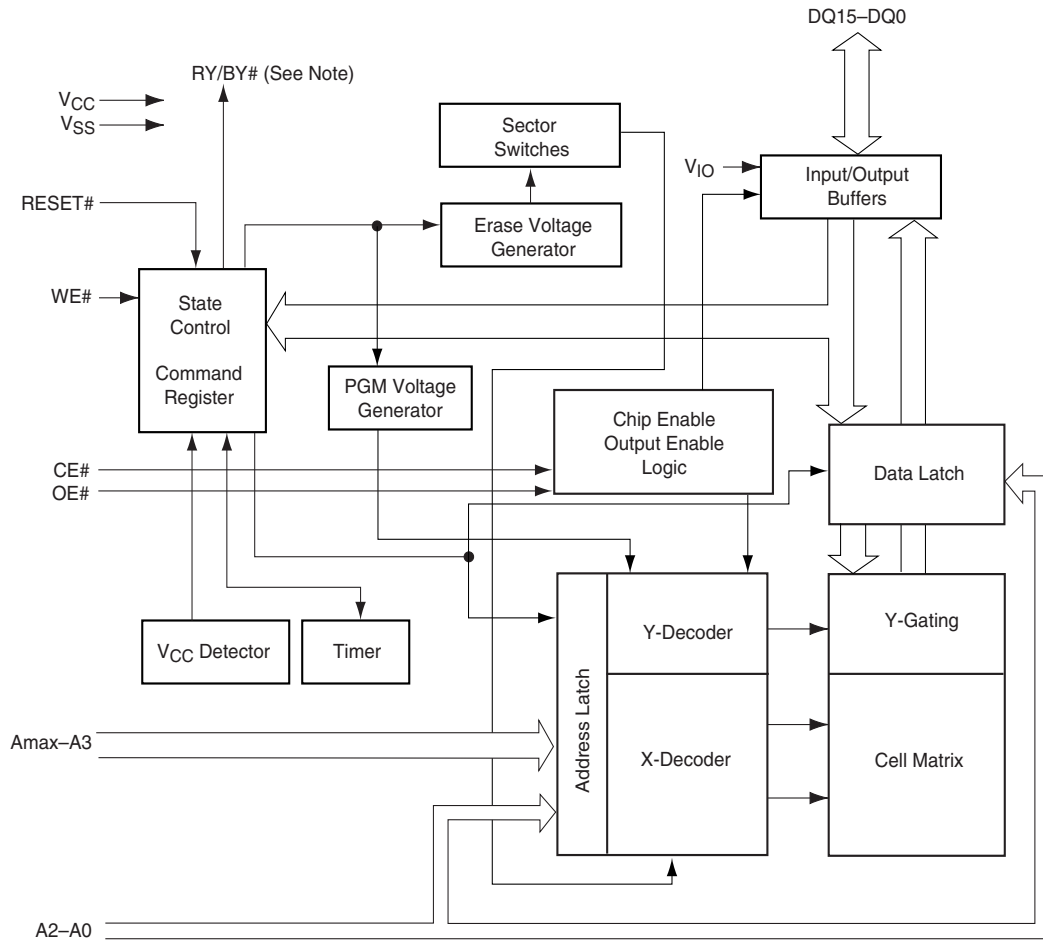

Notes:

1. RY/BY# is an open drain output.
2. A_{max} = A₂₂ (PL127J), A₂₁ (PL064J), A₂₀ (PL032J)

Simultaneous Read/Write Block Diagram

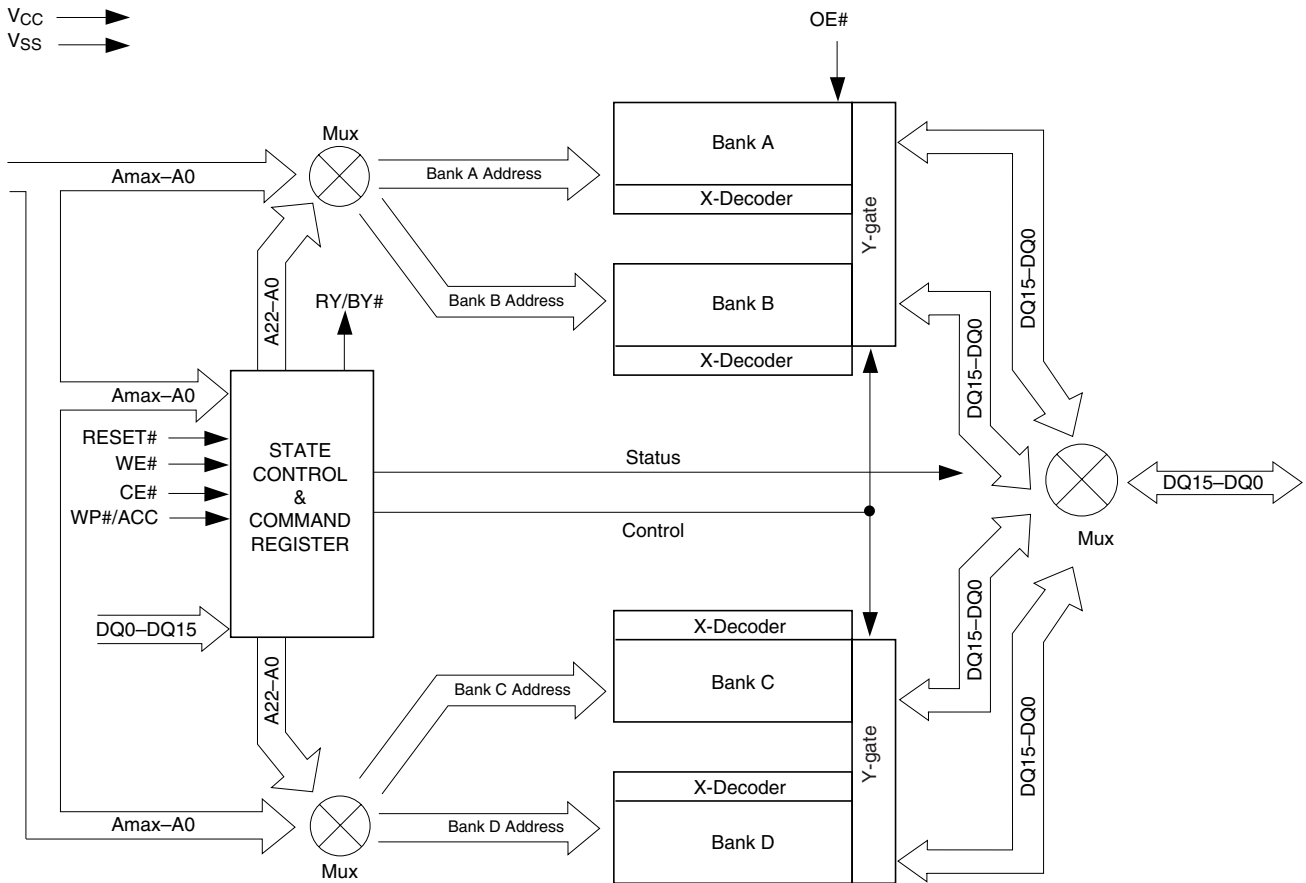

Note: Amax = A22 (PL127J), A21 (PL064J), A20 (PL032J)

Note: Pinout shown for PL127J.

Pin Description

Amax-A0	=	Address bus
DQ15-DQ0	=	16-bit data inputs/outputs/float
CE#	=	Chip Enable Inputs
OE#	=	Output Enable Input
WE#	=	Write Enable
V _{SS}	=	Device Ground
NC	=	Pin Not Connected Internally
RY/BY#	=	Ready/Busy output and open drain. When RY/BY# = V _{IH} , the device is ready to accept read operations and commands. When RY/BY# = V _{OL} , the device is either executing an embedded algorithm or the device is executing a hardware reset operation.
WP#/ACC	=	Write Protect/Acceleration Input. When WP#/ACC = V _{IL} , the highest and lowest two 4K-word sectors are write protected regardless of other sector protection configurations. When WP#/ACC = V _{IH} , these sector are unprotected unless the DYB or PPB is programmed. When WP#/ACC = 12V, program and erase operations are accelerated.
V _{IO}	=	Input/Output Buffer Power Supply (1.65 V to 1.95 V (for PL127J) or 2.7 V to 3.6 V (for all PLxxxJ devices))
V _{CC}	=	Chip Power Supply (2.7 V to 3.6 V or 2.7 to 3.3 V)
RESET#	=	Hardware Reset Pin
CE#1	=	Chip Enable Inputs

Notes:

1. Amax = A22 (PL127J), A21 (PL064J), A20 (PL032J)

Logic Symbol

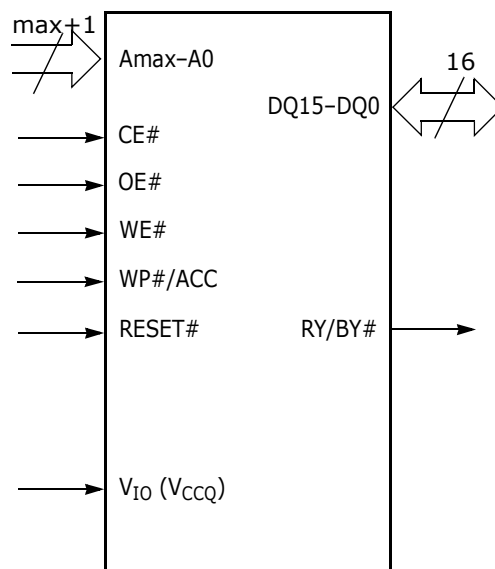

Device Bus Operations

This section describes the requirements and use of the device bus operations, which are initiated through the internal command register. The command register itself does not occupy any addressable memory location. The register is a latch used to store the commands, along with the address and data information needed to execute the command. The contents of the register serve as inputs to the internal state machine. The state machine outputs dictate the function of the device. Table 1 lists the device bus operations, the inputs and control levels they require, and the resulting output. The following subsections describe each of these operations in further detail.

Table 1. PLI27J Device Bus Operations

Operation	CE#	OE#	WE#	RESET#	WP#/ACC	Addresses (Amax-A0)	DQ15-DQ0
Read	L	L	H	H	X	A _{IN}	D _{OUT}
Write	L	H	L	H	X (Note 2)	A _{IN}	D _{IN}
Standby	V _{IO} ± 0.3 V	X	X	V _{IO} ± 0.3 V	X (Note 2)	X	High-Z
Output Disable	L	H	H	H	X	X	High-Z
Reset	X	X	X	L	X	X	High-Z
Temporary Sector Unprotect (High Voltage)	X	X	X	V _{ID}	X	A _{IN}	D _{IN}

Legend: L = Logic Low = V_{IL}, H = Logic High = V_{IH}, V_{ID} = 11.5-12.5 V, V_{HH} = 8.5-9.5 V, X = Don't Care, SA = Sector Address, A_{IN} = Address In, D_{IN} = Data In, D_{OUT} = Data Out

Notes:

1. The sector protect and sector unprotect functions may also be implemented via programming equipment. See the High Voltage Sector Protection section.
2. WP#/ACC must be high when writing to upper two and lower two sectors.

Requirements for Reading Array Data

To read array data from the outputs, the system must drive the OE# and appropriate CE# pins. OE# is the output control and gates array data to the output pins. WE# should remain at V_{IH}.

The internal state machine is set for reading array data upon device power-up, or after a hardware reset. This ensures that no spurious alteration of the memory content occurs during the power transition. No command is necessary in this mode to obtain array data. Standard microprocessor read cycles that assert valid addresses on the device address inputs produce valid data on the device data outputs. Each bank remains enabled for read access until the command register contents are altered.

Refer to Table 23 for timing specifications and to Figure 11 for the timing diagram. I_{CC1} in the DC Characteristics table represents the active current specification for reading array data.

Random Read (Non-Page Read)

Address access time (t_{ACC}) is equal to the delay from stable addresses to valid output data. The chip enable access time (t_{CE}) is the delay from the stable addresses and stable CE# to valid data at the output inputs. The output enable

access time is the delay from the falling edge of the OE# to valid data at the output inputs (assuming the addresses have been stable for at least $t_{ACC-t_{OE}}$ time).

Page Mode Read

The device is capable of fast page mode read and is compatible with the page mode Mask ROM read operation. This mode provides faster read access speed for random locations within a page. Address bits Amax-A3 select an 8 word page, and address bits A2-A0 select a specific word within that page. This is an asynchronous operation with the microprocessor supplying the specific word location.

The random or initial page access is t_{ACC} or t_{CE} and subsequent page read accesses (as long as the locations specified by the microprocessor falls within that page) is equivalent to t_{PACC} . Fast page mode accesses are obtained by keeping Amax-A3 constant and changing A2-A0 to select the specific word within that page.

Table 2. Page Select

Word	A2	A1	A0
Word 0	0	0	0
Word 1	0	0	1
Word 2	0	1	0
Word 3	0	1	1
Word 4	1	0	0
Word 5	1	0	1
Word 6	1	1	0
Word 7	1	1	1

Simultaneous Read/Write Operation

In addition to the conventional features (read, program, erase-suspend read, and erase-suspend program), the device is capable of reading data from one bank of memory while a program or erase operation is in progress in another bank of memory (simultaneous operation). The bank can be selected by bank addresses (PL127J): A22-A20, L064J): A21-A19, PL032J): A20-A18) with zero latency.

The simultaneous operation can execute multi-function mode in the same bank.

Table 3. Bank Select

Bank	PL127J: A22-A20 PL064J: A21-A19 PL032J: A20-A18
Bank A	000
Bank B	001, 010, 011
Bank C	100, 101, 110
Bank D	111

Writing Commands/Command Sequences

To write a command or command sequence (which includes programming data to the device and erasing sectors of memory), the system must drive WE# and CE# to V_{IL} , and OE# to V_{IH} .

The device features an **Unlock Bypass** mode to facilitate faster programming. Once a bank enters the Unlock Bypass mode, only two write cycles are required to program a word, instead of four. The “Word Program Command Sequence” section has details on programming data to the device using both standard and Unlock Bypass command sequences.

An erase operation can erase one sector, multiple sectors, or the entire device. [Table 4](#) indicates the set of address space that each sector occupies. A “bank address” is the set of address bits required to uniquely select a bank. Similarly, a “sector address” refers to the address bits required to uniquely select a sector. The “Command Definitions” section has details on erasing a sector or the entire chip, or suspending/resuming the erase operation.

I_{CC2} in the DC Characteristics table represents the active current specification for the write mode. See the timing specification tables and timing diagrams in the Reset for write operations.

Accelerated Program Operation

The device offers accelerated program operations through the ACC function. This function is primarily intended to allow faster manufacturing throughput at the factory.

If the system asserts V_{HH} on this pin, the device automatically enters the aforementioned Unlock Bypass mode, temporarily unprotects any protected sectors, and uses the higher voltage on the pin to reduce the time required for program operations. The system would use a two-cycle program command sequence as required by the Unlock Bypass mode. Removing V_{HH} from the WP#/ACC pin returns the device to normal operation. *Note that V_{HH} must not be asserted on WP#/ACC for operations other than accelerated programming, or device damage may result. In addition, the WP#/ACC pin should be raised to V_{CC} when not in use. That is, the WP#/ACC pin should not be left floating or unconnected; inconsistent behavior of the device may result.*

Autoselect Functions

If the system writes the autoselect command sequence, the device enters the autoselect mode. The system can then read autoselect codes from the internal register (which is separate from the memory array) on DQ15–DQ0. Standard read cycle timings apply in this mode. Refer to the Secured Silicon Sector Addresses and Autoselect Command Sequence for more information.

Standby Mode

When the system is not reading or writing to the device, it can place the device in the standby mode. In this mode, current consumption is greatly reduced, and the outputs are placed in the high impedance state, independent of the OE# input.

The device enters the CMOS standby mode when the CE# and RESET# pins are both held at $V_{IO} \pm 0.3$ V. (Note that this is a more restricted voltage range than V_{IH} .) If CE# and RESET# are held at V_{IH} , but not within $V_{IO} \pm 0.3$ V, the device will be in the standby mode, but the standby current will be greater. The device

requires standard access time (t_{CE}) for read access when the device is in either of these standby modes, before it is ready to read data.

If the device is deselected during erasure or programming, the device draws active current until the operation is completed.

I_{CC3} in "DC Characteristics" represents the CMOS standby current specification.

Automatic Sleep Mode

The automatic sleep mode minimizes Flash device energy consumption. The device automatically enables this mode when addresses remain stable for $t_{ACC} + 30$ ns. The automatic sleep mode is independent of the CE#, WE#, and OE# control signals. Standard address access timings provide new data when addresses are changed. While in sleep mode, output data is latched and always available to the system. Note that during automatic sleep mode, OE# must be at V_{IH} before the device reduces current to the stated sleep mode specification. I_{CC5} in "DC Characteristics" represents the automatic sleep mode current specification.

RESET#: Hardware Reset Pin

The RESET# pin provides a hardware method of resetting the device to reading array data. When the RESET# pin is driven low for at least a period of t_{RP} , the device immediately terminates any operation in progress, tristates all output pins, and ignores all read/write commands for the duration of the RESET# pulse. The device also resets the internal state machine to reading array data. The operation that was interrupted should be reinitiated once the device is ready to accept another command sequence, to ensure data integrity.

Current is reduced for the duration of the RESET# pulse. When RESET# is held at $V_{SS} \pm 0.3$ V, the device draws CMOS standby current (I_{CC4}). If RESET# is held at V_{IL} but not within $V_{SS} \pm 0.3$ V, the standby current will be greater.

The RESET# pin may be tied to the system reset circuitry. A system reset would thus also reset the Flash memory, enabling the system to read the boot-up firmware from the Flash memory.

If RESET# is asserted during a program or erase operation, the RY/BY# pin remains a "0" (busy) until the internal reset operation is complete, which requires a time of t_{READY} (during Embedded Algorithms). The system can thus monitor RY/BY# to determine whether the reset operation is complete. If RESET# is asserted when a program or erase operation is not executing (RY/BY# pin is "1"), the reset operation is completed within a time of t_{READY} (not during Embedded Algorithms). The system can read data t_{RH} after the RESET# pin returns to V_{IH} .

Refer to the AC Characteristic tables for RESET# parameters and to 13 for the timing diagOutput Disable Mode

When the OE# input is at V_{IH} , output from the device is disabled. The output pins (except for RY/BY#) are placed in the highest Impedance state.

Table 4. PLI27J Sector Architecture

Bank	Sector	Sector Address (A22-AI2)	Sector Size (Kwords)	Address Range (x16)
Bank A	SA0	0000000000	4	00000h-00FFFh
	SA1	0000000001	4	001000h-001FFFh
	SA2	0000000010	4	002000h-002FFFh
	SA3	0000000011	4	003000h-003FFFh
	SA4	0000000100	4	004000h-004FFFh
	SA5	0000000101	4	005000h-005FFFh
	SA6	0000000110	4	006000h-006FFFh
	SA7	0000000111	4	007000h-007FFFh
	SA8	0000001XXX	32	008000h-00FFFFh
	SA9	0000010XXX	32	010000h-017FFFh
	SA10	0000011XXX	32	018000h-01FFFFh
	SA11	0000100XXX	32	020000h-027FFFh
	SA12	0000101XXX	32	028000h-02FFFFh
	SA13	0000110XXX	32	030000h-037FFFh
	SA14	0000111XXX	32	038000h-03FFFFh
	SA15	00001000XXX	32	040000h-047FFFh
	SA16	00001001XXX	32	048000h-04FFFFh
	SA17	00001010XXX	32	050000h-057FFFh
	SA18	00001011XXX	32	058000h-05FFFFh
	SA19	00001100XXX	32	060000h-067FFFh
	SA20	00001101XXX	32	068000h-06FFFFh
	SA21	00001110XXX	32	070000h-077FFFh
	SA22	00001111XXX	32	078000h-07FFFFh
	SA23	00010000XXX	32	080000h-087FFFh
	SA24	00010001XXX	32	088000h-08FFFFh
	SA25	00010010XXX	32	090000h-097FFFh
	SA26	00010011XXX	32	098000h-09FFFFh
	SA27	00010100XXX	32	0A0000h-0A7FFFh
	SA28	00010101XXX	32	0A8000h-0AFFFFh
	SA29	00010110XXX	32	0B0000h-0B7FFFh
	SA30	00010111XXX	32	0B8000h-0BFFFFh
	SA31	00011000XXX	32	0C0000h-0C7FFFh
	SA32	00011001XXX	32	0C8000h-0CFFFFh
	SA33	00011010XXX	32	0D0000h-0D7FFFh
	SA34	00011011XXX	32	0D8000h-0DFFFFh
	SA35	00011100XXX	32	0E0000h-0E7FFFh
	SA36	00011101XXX	32	0E8000h-0EFFFFh
	SA37	00011110XXX	32	0F0000h-0F7FFFh
SA38	00011111XXX	32	0F8000h-0FFFFh	

Table 4. PLI27J Sector Architecture (Continued)

Bank	Sector	Sector Address (A22-AI2)	Sector Size (Kwords)	Address Range (x16)
Bank B	SA39	00100000XXX	32	100000h-107FFFh
	SA40	00100001XXX	32	108000h-10FFFFh
	SA41	00100010XXX	32	110000h-117FFFh
	SA42	00100011XXX	32	118000h-11FFFFh
	SA43	00100100XXX	32	120000h-127FFFh
	SA44	00100101XXX	32	128000h-12FFFFh
	SA45	00100110XXX	32	130000h-137FFFh
	SA46	00100111XXX	32	138000h-13FFFFh
	SA47	00101000XXX	32	140000h-147FFFh
	SA48	00101001XXX	32	148000h-14FFFFh
	SA49	00101010XXX	32	150000h-157FFFh
	SA50	00101011XXX	32	158000h-15FFFFh
	SA51	00101100XXX	32	160000h-167FFFh
	SA52	00101101XXX	32	168000h-16FFFFh
	SA53	00101110XXX	32	170000h-177FFFh
	SA54	00101111XXX	32	178000h-17FFFFh
	SA55	00110000XXX	32	180000h-187FFFh
	SA56	00110001XXX	32	188000h-18FFFFh
	SA57	00110010XXX	32	190000h-197FFFh
	SA58	00110011XXX	32	198000h-19FFFFh
	SA59	00110100XXX	32	1A0000h-1A7FFFh
	SA60	00110101XXX	32	1A8000h-1AFFFFh
	SA61	00110110XXX	32	1B0000h-1B7FFFh
	SA62	00110111XXX	32	1B8000h-1BFFFFh
	SA63	00111000XXX	32	1C0000h-1C7FFFh
	SA64	00111001XXX	32	1C8000h-1CFFFFh
	SA65	00111010XXX	32	1D0000h-1D7FFFh
	SA66	00111011XXX	32	1D8000h-1DFFFFh
SA67	00111100XXX	32	1E0000h-1E7FFFh	
SA68	00111101XXX	32	1E8000h-1EFFFFh	
SA69	00111110XXX	32	1F0000h-1F7FFFh	
SA70	00111111XXX	32	1F8000h-1FFFFFh	
SA71	01000000XXX	32	200000h-207FFFh	
SA72	01000001XXX	32	208000h-20FFFFh	
SA73	01000010XXX	32	210000h-217FFFh	
SA74	01000011XXX	32	218000h-21FFFFh	
SA75	01000100XXX	32	220000h-227FFFh	
SA76	01000101XXX	32	228000h-22FFFFh	
SA77	01000110XXX	32	230000h-237FFFh	
SA78	01000111XXX	32	238000h-23FFFFh	

Table 4. PLI27J Sector Architecture (Continued)

Bank	Sector	Sector Address (A22-AI2)	Sector Size (Kwords)	Address Range (x16)
Bank B	SA79	01001000XXX	32	240000h-247FFFh
	SA80	01001001XXX	32	248000h-24FFFFh
	SA81	01001010XXX	32	250000h-257FFFh
	SA82	01001011XXX	32	258000h-25FFFFh
	SA83	01001100XXX	32	260000h-267FFFh
	SA84	01001101XXX	32	268000h-26FFFFh
	SA85	01001110XXX	32	270000h-277FFFh
	SA86	01001111XXX	32	278000h-27FFFFh
	SA87	01010000XXX	32	280000h-287FFFh
	SA88	01010001XXX	32	288000h-28FFFFh
	SA89	01010010XXX	32	290000h-297FFFh
	SA90	01010011XXX	32	298000h-29FFFFh
	SA91	01010100XXX	32	2A0000h-2A7FFFh
	SA92	01010101XXX	32	2A8000h-2AFFFFh
	SA93	01010110XXX	32	2B0000h-2B7FFFh
	SA94	01010111XXX	32	2B8000h-2BFFFFh
	SA95	01011000XXX	32	2C0000h-2C7FFFh
	SA96	01011001XXX	32	2C8000h-2CFFFFh
	SA97	01011010XXX	32	2D0000h-2D7FFFh
	SA98	01011011XXX	32	2D8000h-2DFFFFh
	SA99	01011100XXX	32	2E0000h-2E7FFFh
	SA100	01011101XXX	32	2E8000h-2EFFFFh
	SA101	01011110XXX	32	2F0000h-2F7FFFh
	SA102	01011111XXX	32	2F8000h-2FFFFFh
	SA103	01100000XXX	32	300000h-307FFFh
	SA104	01100001XXX	32	308000h-30FFFFh
	SA105	01100010XXX	32	310000h-317FFFh
	SA106	01100011XXX	32	318000h-31FFFFh
	SA107	01100100XXX	32	320000h-327FFFh
	SA108	01100101XXX	32	328000h-32FFFFh
	SA109	01100110XXX	32	330000h-337FFFh
	SA110	01100111XXX	32	338000h-33FFFFh
SA111	01101000XXX	32	340000h-347FFFh	
SA112	01101001XXX	32	348000h-34FFFFh	
SA113	01101010XXX	32	350000h-357FFFh	
SA114	01101011XXX	32	358000h-35FFFFh	
SA115	01101100XXX	32	360000h-367FFFh	
SA116	01101101XXX	32	368000h-36FFFFh	
SA117	01101110XXX	32	370000h-377FFFh	
SA118	01101111XXX	32	378000h-37FFFFh	

Table 4. PLI27J Sector Architecture (Continued)

Bank	Sector	Sector Address (A22-AI2)	Sector Size (Kwords)	Address Range (x16)
Bank B	SA119	01110000XXX	32	380000h-387FFFh
	SA120	01110001XXX	32	388000h-38FFFFh
	SA121	01110010XXX	32	390000h-397FFFh
	SA122	01110011XXX	32	398000h-39FFFFh
	SA123	01110100XXX	32	3A0000h-3A7FFFh
	SA124	01110101XXX	32	3A8000h-3AFFFFh
	SA125	01110110XXX	32	3B0000h-3B7FFFh
	SA126	01110111XXX	32	3B8000h-3BFFFFh
	SA127	01111000XXX	32	3C0000h-3C7FFFh
	SA128	01111001XXX	32	3C8000h-3CFFFFh
	SA129	01111010XXX	32	3D0000h-3D7FFFh
	SA130	01111011XXX	32	3D8000h-3DFFFFh
	SA131	01111100XXX	32	3E0000h-3E7FFFh
	SA132	01111101XXX	32	3E8000h-3EFFFFh
SA133	01111110XXX	32	3F0000h-3F7FFFh	
SA134	01111111XXX	32	3F8000h-3FFFFFh	
Bank C	SA135	10000000XXX	32	400000h-407FFFh
	SA136	10000001XXX	32	408000h-40FFFFh
	SA137	10000010XXX	32	410000h-417FFFh
	SA138	10000011XXX	32	418000h-41FFFFh
	SA139	10000100XXX	32	420000h-427FFFh
	SA140	10000101XXX	32	428000h-42FFFFh
	SA141	10000110XXX	32	430000h-437FFFh
	SA142	10000111XXX	32	438000h-43FFFFh
	SA143	10001000XXX	32	440000h-447FFFh
	SA144	10001001XXX	32	448000h-44FFFFh
	SA145	10001010XXX	32	450000h-457FFFh
	SA146	10001011XXX	32	458000h-45FFFFh
	SA147	10001100XXX	32	460000h-467FFFh
	SA148	10001101XXX	32	468000h-46FFFFh
SA149	10001110XXX	32	470000h-477FFFh	
SA150	10001111XXX	32	478000h-47FFFFh	
SA151	10010000XXX	32	480000h-487FFFh	
SA152	10010001XXX	32	488000h-48FFFFh	
SA153	10010010XXX	32	490000h-497FFFh	
SA154	10010011XXX	32	498000h-49FFFFh	
SA155	10010100XXX	32	4A0000h-4A7FFFh	
SA156	10010101XXX	32	4A8000h-4AFFFFh	
SA157	10010110XXX	32	4B0000h-4B7FFFh	
SA158	10010111XXX	32	4B8000h-4BFFFFh	

Table 4. PLI27J Sector Architecture (Continued)

Bank	Sector	Sector Address (A22-AI2)	Sector Size (Kwords)	Address Range (x16)
Bank C	SA159	10011000XXX	32	4C0000h-4C7FFFh
	SA160	10011001XXX	32	4C8000h-4CFFFFh
	SA161	10011010XXX	32	4D0000h-4D7FFFh
	SA162	10011011XXX	32	4D8000h-4DFFFFh
	SA163	10011100XXX	32	4E0000h-4E7FFFh
	SA164	10011101XXX	32	4E8000h-4EFFFFh
	SA165	10011110XXX	32	4F0000h-4F7FFFh
	SA166	10011111XXX	32	4F8000h-4FFFFFh
	SA167	10100000XXX	32	500000h-507FFFh
	SA168	10100001XXX	32	508000h-50FFFFh
	SA169	10100010XXX	32	510000h-517FFFh
	SA170	10100011XXX	32	518000h-51FFFFh
	SA171	10100100XXX	32	520000h-527FFFh
	SA172	10100101XXX	32	528000h-52FFFFh
	SA173	10100110XXX	32	530000h-537FFFh
	SA174	10100111XXX	32	538000h-53FFFFh
	SA175	10101000XXX	32	540000h-547FFFh
	SA176	10101001XXX	32	548000h-54FFFFh
	SA177	10101010XXX	32	550000h-557FFFh
	SA178	10101011XXX	32	558000h-55FFFFh
	SA179	10101100XXX	32	560000h-567FFFh
	SA180	10101101XXX	32	568000h-56FFFFh
	SA181	10101110XXX	32	570000h-577FFFh
	SA182	10101111XXX	32	578000h-57FFFFh
	SA183	10110000XXX	32	580000h-587FFFh
	SA184	10110001XXX	32	588000h-58FFFFh
	SA185	10110010XXX	32	590000h-597FFFh
	SA186	10110011XXX	32	598000h-59FFFFh
	SA187	10110100XXX	32	5A0000h-5A7FFFh
	SA188	10110101XXX	32	5A8000h-5AFFFFh
	SA189	10110110XXX	32	5B0000h-5B7FFFh
	SA190	10110111XXX	32	5B8000h-5BFFFFh
SA191	10111000XXX	32	5C0000h-5C7FFFh	
SA192	10111001XXX	32	5C8000h-5CFFFFh	
SA193	10111010XXX	32	5D0000h-5D7FFFh	
SA194	10111011XXX	32	5D8000h-5DFFFFh	
SA195	10111100XXX	32	5E0000h-5E7FFFh	
SA196	10111101XXX	32	5E8000h-5EFFFFh	
SA197	10111110XXX	32	5F0000h-5F7FFFh	
SA198	10111111XXX	32	5F8000h-5FFFFFh	

Table 4. PLI27J Sector Architecture (Continued)

Bank	Sector	Sector Address (A22-AI2)	Sector Size (Kwords)	Address Range (x16)
Bank C	SA199	11000000XXX	32	600000h-607FFFh
	SA200	11000001XXX	32	608000h-60FFFFh
	SA201	11000010XXX	32	610000h-617FFFh
	SA202	11000011XXX	32	618000h-61FFFFh
	SA203	11000100XXX	32	620000h-627FFFh
	SA204	11000101XXX	32	628000h-62FFFFh
	SA205	11000110XXX	32	630000h-637FFFh
	SA206	11000111XXX	32	638000h-63FFFFh
	SA207	11001000XXX	32	640000h-647FFFh
	SA208	11001001XXX	32	648000h-64FFFFh
	SA209	11001010XXX	32	650000h-657FFFh
	SA210	11001011XXX	32	658000h-65FFFFh
	SA211	11001100XXX	32	660000h-667FFFh
	SA212	11001101XXX	32	668000h-66FFFFh
	SA213	11001110XXX	32	670000h-677FFFh
	SA214	11001111XXX	32	678000h-67FFFFh
	SA215	11010000XXX	32	680000h-687FFFh
	SA216	11010001XXX	32	688000h-68FFFFh
	SA217	11010010XXX	32	690000h-697FFFh
	SA218	11010011XXX	32	698000h-69FFFFh
	SA219	11010100XXX	32	6A0000h-6A7FFFh
	SA220	11010101XXX	32	6A8000h-6AFFFFh
	SA221	11010110XXX	32	6B0000h-6B7FFFh
	SA222	11010111XXX	32	6B8000h-6BFFFFh
	SA223	11011000XXX	32	6C0000h-6C7FFFh
	SA224	11011001XXX	32	6C8000h-6CFFFFh
	SA225	11011010XXX	32	6D0000h-6D7FFFh
	SA226	11011011XXX	32	6D8000h-6DFFFFh
SA227	11011100XXX	32	6E0000h-6E7FFFh	
SA228	11011101XXX	32	6E8000h-6EFFFFh	
SA229	11011110XXX	32	6F0000h-6F7FFFh	
SA230	11011111XXX	32	6F8000h-6FFFFFh	

Table 4. PLI27J Sector Architecture (Continued)

Bank	Sector	Sector Address (A22-AI2)	Sector Size (Kwords)	Address Range (x16)
Bank D	SA231	11100000XXX	32	700000h-707FFFh
	SA232	11100001XXX	32	708000h-70FFFFh
	SA233	11100010XXX	32	710000h-717FFFh
	SA234	11100011XXX	32	718000h-71FFFFh
	SA235	11100100XXX	32	720000h-727FFFh
	SA236	11100101XXX	32	728000h-72FFFFh
	SA237	11100110XXX	32	730000h-737FFFh
	SA238	11100111XXX	32	738000h-73FFFFh
	SA239	11101000XXX	32	740000h-747FFFh
	SA240	11101001XXX	32	748000h-74FFFFh
	SA241	11101010XXX	32	750000h-757FFFh
	SA242	11101011XXX	32	758000h-75FFFFh
	SA243	11101100XXX	32	760000h-767FFFh
	SA244	11101101XXX	32	768000h-76FFFFh
	SA245	11101110XXX	32	770000h-777FFFh
	SA246	11101111XXX	32	778000h-77FFFFh
	SA247	11110000XXX	32	780000h-787FFFh
	SA248	11110001XXX	32	788000h-78FFFFh
	SA249	11110010XXX	32	790000h-797FFFh
	SA250	11110011XXX	32	798000h-79FFFFh
	SA251	11110100XXX	32	7A0000h-7A7FFFh
	SA252	11110101XXX	32	7A8000h-7AFFFFh
	SA253	11110110XXX	32	7B0000h-7B7FFFh
	SA254	11110111XXX	32	7B8000h-7BFFFFh
	SA255	11111000XXX	32	7C0000h-7C7FFFh
	SA256	11111001XXX	32	7C8000h-7CFFFFh
	SA257	11111010XXX	32	7D0000h-7D7FFFh
	SA258	11111011XXX	32	7D8000h-7DFFFFh
	SA259	11111100XXX	32	7E0000h-7E7FFFh
	SA260	11111101XXX	32	7E8000h-7EFFFFh
SA261	11111110XXX	32	7F0000h-7F7FFFh	
SA262	11111111000	4	7F8000h-7F8FFFh	
SA263	11111111001	4	7F9000h-7F9FFFh	
SA264	11111111010	4	7FA000h-7FAFFFh	
SA265	11111111011	4	7FB000h-7FBFFFh	
SA266	11111111100	4	7FC000h-7FCFFFh	
SA267	11111111101	4	7FD000h-7FDFFFh	
SA268	11111111110	4	7FE000h-7FEFFFh	
SA269	11111111111	4	7FF000h-7FFFFFh	

Table 5. PL064J Sector Architecture

Bank	Sector	Sector Address (A22-A12)	Sector Size (Kwords)	Address Range (x16)
Bank A	SA0	000000000	4	000000h-000FFFh
	SA1	000000001	4	001000h-001FFFh
	SA2	000000010	4	002000h-002FFFh
	SA3	000000011	4	003000h-003FFFh
	SA4	000000100	4	004000h-004FFFh
	SA5	000000101	4	005000h-005FFFh
	SA6	000000110	4	006000h-006FFFh
	SA7	000000111	4	007000h-007FFFh
	SA8	000001XXX	32	008000h-00FFFFh
	SA9	0000010XXX	32	010000h-017FFFh
	SA10	0000011XXX	32	018000h-01FFFFh
	SA11	0000100XXX	32	020000h-027FFFh
	SA12	0000101XXX	32	028000h-02FFFFh
	SA13	0000110XXX	32	030000h-037FFFh
	SA14	0000111XXX	32	038000h-03FFFFh
	SA15	0001000XXX	32	040000h-047FFFh
	SA16	0001001XXX	32	048000h-04FFFFh
	SA17	0001010XXX	32	050000h-057FFFh
	SA18	0001011XXX	32	058000h-05FFFFh
	SA19	0001100XXX	32	060000h-067FFFh
	SA20	0001101XXX	32	068000h-06FFFFh
	SA21	0001110XXX	32	070000h-077FFFh
SA22	0001111XXX	32	078000h-07FFFFh	
Bank B	SA23	0010000XXX	32	080000h-087FFFh
	SA24	0010001XXX	32	088000h-08FFFFh
	SA25	0010010XXX	32	090000h-097FFFh
	SA26	0010011XXX	32	098000h-09FFFFh
	SA27	0010100XXX	32	0A0000h-0A7FFFh
	SA28	0010101XXX	32	0A8000h-0AFFFFh
	SA29	0010110XXX	32	0B0000h-0B7FFFh
	SA30	0010111XXX	32	0B8000h-0BFFFFh
	SA31	0011000XXX	32	0C0000h-0C7FFFh
	SA32	0011001XXX	32	0C8000h-0CFFFFh
	SA33	0011010XXX	32	0D0000h-0D7FFFh
	SA34	0011011XXX	32	0D8000h-0DFFFFh
	SA35	0011100XXX	32	0E0000h-0E7FFFh
	SA36	0011101XXX	32	0E8000h-0EFFFFh
	SA37	0011110XXX	32	0F0000h-0F7FFFh
	SA38	0011111XXX	32	0F8000h-0FFFFFh
	SA39	0100000XXX	32	100000h-107FFFh
	SA40	0100001XXX	32	108000h-10FFFFh
	SA41	0100010XXX	32	110000h-117FFFh
	SA42	0100011XXX	32	118000h-11FFFFh
	SA43	0100100XXX	32	120000h-127FFFh
	SA44	0100101XXX	32	128000h-12FFFFh
	SA45	0100110XXX	32	130000h-137FFFh
	SA46	0100111XXX	32	138000h-13FFFFh
	SA47	0101000XXX	32	140000h-147FFFh

Table 5. PL064J Sector Architecture (Continued)

Bank	Sector	Sector Address (A22-AI2)	Sector Size (Kwords)	Address Range (xl6)
Bank B	SA48	0101001XXX	32	148000h-14FFFFh
	SA49	0101010XXX	32	150000h-157FFFh
	SA50	0101011XXX	32	158000h-15FFFFh
	SA51	0101100XXX	32	160000h-167FFFh
	SA52	0101101XXX	32	168000h-16FFFFh
	SA53	0101110XXX	32	170000h-177FFFh
	SA54	0101111XXX	32	178000h-17FFFFh
	SA55	0110000XXX	32	180000h-187FFFh
	SA56	0110001XXX	32	188000h-18FFFFh
	SA57	0110010XXX	32	190000h-197FFFh
	SA58	0110011XXX	32	198000h-19FFFFh
	SA59	0110100XXX	32	1A0000h-1A7FFFh
	SA60	0110101XXX	32	1A8000h-1AFFFFh
	SA61	0110110XXX	32	1B0000h-1B7FFFh
	SA62	0110111XXX	32	1B8000h-1BFFFFh
	SA63	0111000XXX	32	1C0000h-1C7FFFh
	SA64	0111001XXX	32	1C8000h-1CFFFFh
	SA65	0111010XXX	32	1D0000h-1D7FFFh
	SA66	0111011XXX	32	1D8000h-1DFFFFh
	SA67	0111100XXX	32	1E0000h-1E7FFFh
SA68	0111101XXX	32	1E8000h-1EFFFFh	
SA69	0111110XXX	32	1F0000h-1F7FFFh	
SA70	0111111XXX	32	1F8000h-1FFFFFh	
Bank C	SA71	1000000XXX	32	200000h-207FFFh
	SA72	1000001XXX	32	208000h-20FFFFh
	SA73	1000010XXX	32	210000h-217FFFh
	SA74	1000011XXX	32	218000h-21FFFFh
	SA75	1000100XXX	32	220000h-227FFFh
	SA76	1000101XXX	32	228000h-22FFFFh
	SA77	1000110XXX	32	230000h-237FFFh
	SA78	1000111XXX	32	238000h-23FFFFh
	SA79	1001000XXX	32	240000h-247FFFh
	SA80	1001001XXX	32	248000h-24FFFFh
	SA81	1001010XXX	32	250000h-257FFFh
	SA82	1001011XXX	32	258000h-25FFFFh
	SA83	1001100XXX	32	260000h-267FFFh
	SA84	1001101XXX	32	268000h-26FFFFh
	SA85	1001110XXX	32	270000h-277FFFh
	SA86	1001111XXX	32	278000h-27FFFFh
Bank C	SA87	1010000XXX	32	280000h-287FFFh
	SA88	1010001XXX	32	288000h-28FFFFh
	SA89	1010010XXX	32	290000h-297FFFh
	SA90	1010011XXX	32	298000h-29FFFFh
	SA91	1010100XXX	32	2A0000h-2A7FFFh
	SA92	1010101XXX	32	2A8000h-2AFFFFh
	SA93	1010110XXX	32	2B0000h-2B7FFFh
	SA94	1010111XXX	32	2B8000h-2BFFFFh
	SA95	1011000XXX	32	2C0000h-2C7FFFh

Table 5. PL064J Sector Architecture (Continued)

Bank	Sector	Sector Address (A22-AI2)	Sector Size (Kwords)	Address Range (x16)
Bank C	SA96	1011001XXX	32	2C8000h-2CFFFFh
	SA97	1011010XXX	32	2D0000h-2D7FFFh
	SA98	1011011XXX	32	2D8000h-2DFFFFh
	SA99	1011100XXX	32	2E0000h-2E7FFFh
	SA100	1011101XXX	32	2E8000h-2EFFFFh
	SA101	1011110XXX	32	2F0000h-2F7FFFh
	SA102	1011111XXX	32	2F8000h-2FFFFFh
	SA103	1100000XXX	32	300000h-307FFFh
	SA104	1100001XXX	32	308000h-30FFFFh
	SA105	1100010XXX	32	310000h-317FFFh
	SA106	1100011XXX	32	318000h-31FFFFh
	SA107	1100100XXX	32	320000h-327FFFh
	SA108	1100101XXX	32	328000h-32FFFFh
	SA109	1100110XXX	32	330000h-337FFFh
	SA110	1100111XXX	32	338000h-33FFFFh
	SA111	1101000XXX	32	340000h-347FFFh
	SA112	1101001XXX	32	348000h-34FFFFh
	SA113	1101010XXX	32	350000h-357FFFh
SA114	1101011XXX	32	358000h-35FFFFh	
SA115	1101100XXX	32	360000h-367FFFh	
SA116	1101101XXX	32	368000h-36FFFFh	
SA117	1101110XXX	32	370000h-377FFFh	
SA118	1101111XXX	32	378000h-37FFFFh	
Bank D	SA119	1110000XXX	32	380000h-387FFFh
	SA120	1110001XXX	32	388000h-38FFFFh
	SA121	1110010XXX	32	390000h-397FFFh
	SA122	1110011XXX	32	398000h-39FFFFh
	SA123	1110100XXX	32	3A0000h-3A7FFFh
	SA124	1110101XXX	32	3A8000h-3AFFFFh
	SA125	1110110XXX	32	3B0000h-3B7FFFh
	SA126	1110111XXX	32	3B8000h-3BFFFFh
	SA127	1111000XXX	32	3C0000h-3C7FFFh
	SA128	1111001XXX	32	3C8000h-3CFFFFh
	SA129	1111010XXX	32	3D0000h-3D7FFFh
	SA130	1111011XXX	32	3D8000h-3DFFFFh
	SA131	1111100XXX	32	3E0000h-3E7FFFh
	SA132	1111101XXX	32	3E8000h-3EFFFFh
	SA133	1111110XXX	32	3F0000h-3F7FFFh
	SA134	1111111000	4	3F8000h-3F8FFFh
	SA135	1111111001	4	3F9000h-3F9FFFh
	SA136	1111111010	4	3FA000h-3FAFFFh
	SA137	1111111011	4	3FB000h-3FBFFFh
	SA138	1111111100	4	3FC000h-3FCFFFh
	SA139	1111111101	4	3FD000h-3FDFFFh
	SA140	1111111110	4	3FE000h-3FEFFFh
	SA141	1111111111	4	3FF000h-3FFFFFh

Table 6. PL032J Sector Architecture

Bank	Sector	Sector Address (A22-AI2)	Sector Size (Kwords)	Address Range (xl6)
Bank A	SA0	00000000	4	000000h-000FFFh
	SA1	00000001	4	001000h-001FFFh
	SA2	00000010	4	002000h-002FFFh
	SA3	00000011	4	003000h-003FFFh
	SA4	00000100	4	004000h-004FFFh
	SA5	00000101	4	005000h-005FFFh
	SA6	00000110	4	006000h-006FFFh
	SA7	00000111	4	007000h-007FFFh
	SA8	000001XXX	32	008000h-00FFFFh
	SA9	000010XXX	32	010000h-017FFFh
	SA10	000011XXX	32	018000h-01FFFFh
	SA11	000100XXX	32	020000h-027FFFh
	SA12	000101XXX	32	028000h-02FFFFh
	SA13	000110XXX	32	030000h-037FFFh
SA14	000111XXX	32	038000h-03FFFFh	
Bank B	SA15	001000XXX	32	040000h-047FFFh
	SA16	001001XXX	32	048000h-04FFFFh
	SA17	001010XXX	32	050000h-057FFFh
	SA18	001011XXX	32	058000h-05FFFFh
	SA19	001100XXX	32	060000h-067FFFh
	SA20	001101XXX	32	068000h-06FFFFh
	SA21	001110XXX	32	070000h-077FFFh
	SA22	001111XXX	32	078000h-07FFFFh
	SA23	010000XXX	32	080000h-087FFFh
	SA24	010001XXX	32	088000h-08FFFFh
	SA25	010010XXX	32	090000h-097FFFh
	SA26	010011XXX	32	098000h-09FFFFh
	SA27	010100XXX	32	0A0000h-0A7FFFh
	SA28	010101XXX	32	0A8000h-0AFFFFh
	SA29	010110XXX	32	0B0000h-0B7FFFh
	SA30	010111XXX	32	0B8000h-0BFFFFh
	SA31	011000XXX	32	0C0000h-0C7FFFh
	SA32	011001XXX	32	0C8000h-0CFFFFh
	SA33	011010XXX	32	0D0000h-0D7FFFh
	SA34	011011XXX	32	0D8000h-0DFFFFh
	SA35	011100XXX	32	0E0000h-0E7FFFh
	SA36	011101XXX	32	0E8000h-0EFFFFh
	SA37	011110XXX	32	0F0000h-0F7FFFh
	SA38	011111XXX	32	0F8000h-0FFFFFh

Table 6. PL032J Sector Architecture (Continued)

Bank	Sector	Sector Address (A22-AI2)	Sector Size (Kwords)	Address Range (x16)
Bank C	SA39	100000XXX	32	100000h-107FFFh
	SA40	100001XXX	32	108000h-10FFFFh
	SA41	100010XXX	32	110000h-117FFFh
	SA42	100011XXX	32	118000h-11FFFFh
	SA43	100100XXX	32	120000h-127FFFh
	SA44	100101XXX	32	128000h-12FFFFh
	SA45	100110XXX	32	130000h-137FFFh
	SA46	100111XXX	32	138000h-13FFFFh
	SA47	101000XXX	32	140000h-147FFFh
	SA48	101001XXX	32	148000h-14FFFFh
	SA49	101010XXX	32	150000h-157FFFh
	SA50	101011XXX	32	158000h-15FFFFh
	SA51	101100XXX	32	160000h-167FFFh
	SA52	101101XXX	32	168000h-16FFFFh
	SA53	101110XXX	32	170000h-177FFFh
	SA54	101111XXX	32	178000h-17FFFFh
	SA55	110000XXX	32	180000h-187FFFh
	SA56	110001XXX	32	188000h-18FFFFh
	SA57	110010XXX	32	190000h-197FFFh
	SA58	110011XXX	32	198000h-19FFFFh
	SA59	110100XXX	32	1A0000h-1A7FFFh
SA60	110101XXX	32	1A8000h-1AFFFFh	
SA61	110110XXX	32	1B0000h-1B7FFFh	
SA62	110111XXX	32	1B8000h-1BFFFFh	
Bank D	SA63	111000XXX	32	1C0000h-1C7FFFh
	SA64	111001XXX	32	1C8000h-1CFFFFh
	SA65	111010XXX	32	1D0000h-1D7FFFh
	SA66	111011XXX	32	1D8000h-1DFFFFh
	SA67	111100XXX	32	1E0000h-1E7FFFh
	SA68	111101XXX	32	1E8000h-1EFFFFh
	SA69	111110XXX	32	1F0000h-1F7FFFh
	SA70	111111000	4	1F8000h-1F8FFFh
	SA71	111111001	4	1F9000h-1F9FFFh
	SA72	111111010	4	1FA000h-1FAFFFh
	SA73	111111011	4	1FB000h-1FBFFFh
	SA74	111111100	4	1FC000h-1FCFFFh
	SA75	111111101	4	1FD000h-1FDFFFh
	SA76	111111110	4	1FE000h-1FEFFFh
	SA77	111111111	4	1FF000h-1FFFFFh

Table 7. Secured Silicon Sector Addresses

	Sector Size	Address Range
Factory-Locked Area	64 words	000000h-00003Fh
Customer-Lockable Area	64 words	000040h-00007Fh

Autoselect Mode

The autoselect mode provides manufacturer and device identification, and sector protection verification, through identifier codes output on DQ7–DQ0. This mode is primarily intended for programming equipment to automatically match a device to be programmed with its corresponding programming algorithm. However, the autoselect codes can also be accessed in-system through the command register.

When using programming equipment, the autoselect mode requires V_{ID} on address pin A9. Address pins must be as shown in Table 8 and Table 11. In addition, when verifying sector protection, the sector address must appear on the appropriate highest order address bits (see Table 3). Table 8 and Table 11 show the remaining address bits that are don't care. When all necessary bits have been set as required, the programming equipment may then read the corresponding identifier code on DQ7–DQ0. However, the autoselect codes can also be accessed in-system through the command register, for instances when the device is erased or programmed in a system without access to high voltage on the A9 pin. The command sequence is illustrated in Table 17. *Note that if a Bank Address (BA) (on address bits PL127J: A22–A20, PL064J: A21–A19, PL032J: A20–A18) is asserted during the third write cycle of the autoselect command, the host system can read autoselect data that bank and then immediately read array data from the other bank, without exiting the autoselect mode.*

To access the autoselect codes in-system, the host system can issue the autoselect command via the command register, as shown in Table 17. This method does not require V_{ID} . Refer to the Autoselect Command Sequence for more information.

Table 8. Autoselect Codes (High Voltage Method)

Description	CE#	OE#	WE#	Amax to A12	A10	A9	A8	A7	A6	A5 to A4	A3	A2	A1	A0	DQ15 to DQ0				
Manufacturer ID: Spansion products	L	L	H	BA	X	V_{ID}	X	L	L	X	L	L	L	L	0001h				
Device ID	Read Cycle 1	L	L	H	BA	X	V_{ID}	X	L	L	L	L	L	H	227Eh				
	Read Cycle 2	L													H	H	H	L	2220h (PL127J) 2202h (PL064J) 220Ah (PL032J)
	Read Cycle 3	L													H	H	H	H	2200h (PL127J) 2201h (PL064J) 2201h (PL032J)
Sector Protection Verification	L	L	H	SA	X	V_{ID}	X	L	L	L	L	L	H	L	0001h (protected), 0000h (unprotected)				
Secured Silicon Indicator Bit (DQ7, DQ6)	L	L	H	BA	X	V_{ID}	X	X	L	X	L	L	H	H	00C4h (factory and customer locked), 0084h (factory locked), 0004h (not locked)				

Legend: L = Logic Low = V_{IL} , H = Logic High = V_{IH} , BA = Bank Address, SA = Sector Address, X = Don't care.

Note: The autoselect codes may also be accessed in-system via command sequences

Table 9. PLI27J Boot Sector/Sector Block Addresses for Protection/Unprotection

Sector	A22-AI2	Sector/ Sector Block Size	Sector	A22-AI2	Sector/ Sector Block Size
SA0	0000000000	4 Kwords	SA131-SA134	011111XXXXX	128 (4x32) Kwords
SA1	0000000001	4 Kwords	SA135-SA138	100000XXXXX	128 (4x32) Kwords
SA2	0000000010	4 Kwords	SA139-SA142	100001XXXXX	128 (4x32) Kwords
SA3	0000000011	4 Kwords	SA143-SA146	100010XXXXX	128 (4x32) Kwords
SA4	0000000100	4 Kwords	SA147-SA150	100011XXXXX	128 (4x32) Kwords
SA5	0000000101	4 Kwords	SA151-SA154	100100XXXXX	128 (4x32) Kwords
SA6	0000000110	4 Kwords	SA155-SA158	100101XXXXX	128 (4x32) Kwords
SA7	0000000111	4 Kwords	SA159-SA162	100110XXXXX	128 (4x32) Kwords
SA8	00000001XXX	32 Kwords	SA163-SA166	100111XXXXX	128 (4x32) Kwords
SA9	00000010XXX	32 Kwords	SA167-SA170	101000XXXXX	128 (4x32) Kwords
SA10	00000011XXX	32 Kwords	SA171-SA174	101001XXXXX	128 (4x32) Kwords
SA11-SA14	000001XXXXX	128 (4x32) Kwords	SA175-SA178	101010XXXXX	128 (4x32) Kwords
SA15-SA18	000010XXXXX	128 (4x32) Kwords	SA179-SA182	101011XXXXX	128 (4x32) Kwords
SA19-SA22	000011XXXXX	128 (4x32) Kwords	SA183-SA186	101100XXXXX	128 (4x32) Kwords
SA23-SA26	000100XXXXX	128 (4x32) Kwords	SA187-SA190	101101XXXXX	128 (4x32) Kwords
SA27-SA30	000101XXXXX	128 (4x32) Kwords	SA191-SA194	101110XXXXX	128 (4x32) Kwords
SA31-SA34	000110XXXXX	128 (4x32) Kwords	SA195-SA198	101111XXXXX	128 (4x32) Kwords
SA35-SA38	000111XXXXX	128 (4x32) Kwords	SA199-SA202	110000XXXXX	128 (4x32) Kwords
SA39-SA42	001000XXXXX	128 (4x32) Kwords	SA203-SA206	110001XXXXX	128 (4x32) Kwords
SA43-SA46	001001XXXXX	128 (4x32) Kwords	SA207-SA210	110010XXXXX	128 (4x32) Kwords
SA47-SA50	001010XXXXX	128 (4x32) Kwords	SA211-SA214	110011XXXXX	128 (4x32) Kwords
SA51-SA54	001011XXXXX	128 (4x32) Kwords	SA215-SA218	110100XXXXX	128 (4x32) Kwords
SA55-SA58	001100XXXXX	128 (4x32) Kwords	SA219-SA222	110101XXXXX	128 (4x32) Kwords
SA59-SA62	001101XXXXX	128 (4x32) Kwords	SA223-SA226	110110XXXXX	128 (4x32) Kwords
SA63-SA66	001110XXXXX	128 (4x32) Kwords	SA227-SA230	110111XXXXX	128 (4x32) Kwords
SA67-SA70	001111XXXXX	128 (4x32) Kwords	SA231-SA234	111000XXXXX	128 (4x32) Kwords
SA71-SA74	010000XXXXX	128 (4x32) Kwords	SA235-SA238	111001XXXXX	128 (4x32) Kwords
SA75-SA78	010001XXXXX	128 (4x32) Kwords	SA239-SA242	111010XXXXX	128 (4x32) Kwords
SA79-SA82	010010XXXXX	128 (4x32) Kwords	SA243-SA246	111011XXXXX	128 (4x32) Kwords
SA83-SA86	010011XXXXX	128 (4x32) Kwords	SA247-SA250	111100XXXXX	128 (4x32) Kwords
SA87-SA90	010100XXXXX	128 (4x32) Kwords	SA251-SA254	111101XXXXX	128 (4x32) Kwords
SA91-SA94	010101XXXXX	128 (4x32) Kwords	SA255-SA258	111110XXXXX	128 (4x32) Kwords
SA95-SA98	010110XXXXX	128 (4x32) Kwords	SA259	11111100XXX	32 Kwords
SA99-SA102	010111XXXXX	128 (4x32) Kwords	SA260	11111101XXX	32 Kwords
SA103-SA106	011000XXXXX	128 (4x32) Kwords	SA261	11111110XXX	32 Kwords
SA107-SA110	011001XXXXX	128 (4x32) Kwords	SA262	11111111000	4 Kwords
SA111-SA114	011010XXXXX	128 (4x32) Kwords	SA263	11111111001	4 Kwords
SA115-SA118	011011XXXXX	128 (4x32) Kwords	SA264	11111111010	4 Kwords
SA119-SA122	011100XXXXX	128 (4x32) Kwords	SA265	11111111011	4 Kwords
SA123-SA126	011101XXXXX	128 (4x32) Kwords			
SA127-SA130	011110XXXXX	128 (4x32) Kwords			

Table 10. PL064J Boot Sector/Sector Block Addresses for Protection/Unprotection

Sector	A21-A12	Sector/Sector Block Size
SA0	000000000	4 Kwords
SA1	000000001	4 Kwords
SA2	000000010	4 Kwords
SA3	000000011	4 Kwords
SA4	000000100	4 Kwords
SA5	000000101	4 Kwords
SA6	000000110	4 Kwords
SA7	000000111	4 Kwords
SA8	000001XXX	32 Kwords
SA9	000010XXX	32 Kwords
SA10	000011XXX	32 Kwords
SA11-SA14	00001XXXX	128 (4x32) Kwords
SA15-SA18	00010XXXX	128 (4x32) Kwords
SA19-SA22	00011XXXX	128 (4x32) Kwords
SA23-SA26	00100XXXX	128 (4x32) Kwords
SA27-SA30	00101XXXX	128 (4x32) Kwords
SA31-SA34	00110XXXX	128 (4x32) Kwords
SA35-SA38	00111XXXX	128 (4x32) Kwords
SA39-SA42	01000XXXX	128 (4x32) Kwords
SA43-SA46	01001XXXX	128 (4x32) Kwords
SA47-SA50	01010XXXX	128 (4x32) Kwords
SA51-SA54	01011XXXX	128 (4x32) Kwords
SA55-SA58	01100XXXX	128 (4x32) Kwords
SA59-SA62	01101XXXX	128 (4x32) Kwords
SA63-SA66	01110XXXX	128 (4x32) Kwords
SA67-SA70	01111XXXX	128 (4x32) Kwords
SA71-SA74	10000XXXX	128 (4x32) Kwords
SA75-SA78	10001XXXX	128 (4x32) Kwords
SA79-SA82	10010XXXX	128 (4x32) Kwords
SA83-SA86	10011XXXX	128 (4x32) Kwords
SA87-SA90	10100XXXX	128 (4x32) Kwords
SA91-SA94	10101XXXX	128 (4x32) Kwords
SA95-SA98	10110XXXX	128 (4x32) Kwords
SA99-SA102	10111XXXX	128 (4x32) Kwords
SA103-SA106	11000XXXX	128 (4x32) Kwords
SA107-SA110	11001XXXX	128 (4x32) Kwords
SA111-SA114	11010XXXX	128 (4x32) Kwords
SA115-SA118	11011XXXX	128 (4x32) Kwords
SA119-SA122	11100XXXX	128 (4x32) Kwords
SA123-SA126	11101XXXX	128 (4x32) Kwords
SA127-SA130	11110XXXX	128 (4x32) Kwords
SA131	1111100XXX	32 Kwords
SA132	1111101XXX	32 Kwords
SA133	1111110XXX	32 Kwords
SA134	1111111000	4 Kwords
SA135	1111111001	4 Kwords
SA136	1111111010	4 Kwords
SA137	1111111011	4 Kwords
SA138	1111111100	4 Kwords

Table 10. PL064J Boot Sector/Sector Block Addresses for Protection/Unprotection

Sector	A2I-AI2	Sector/Sector Block Size
SA139	1111111101	4 Kwords
SA140	1111111110	4 Kwords
SA141	1111111111	4 Kwords

Table II. PL032J Boot Sector/Sector Block Addresses for Protection/Unprotection

Sector	A2I-AI2	Sector/Sector Block Size
SA0	000000000	4 Kwords
SA1	000000001	4 Kwords
SA2	000000010	4 Kwords
SA3	000000011	4 Kwords
SA4	000000100	4 Kwords
SA5	000000101	4 Kwords
SA6	000000110	4 Kwords
SA7	000000111	4 Kwords
SA8	000001XXX	32 Kwords
SA9	000010XXX	32 Kwords
SA10	000011XXX	32 Kwords
SA11-SA14	0001XXXXX	128 (4x32) Kwords
SA15-SA18	0010XXXXX	128 (4x32) Kwords
SA19-SA22	0011XXXXX	128 (4x32) Kwords
SA23-SA26	0100XXXXX	128 (4x32) Kwords
SA27-SA30	0101XXXXX	128 (4x32) Kwords
SA31-SA34	0110XXXXX	128 (4x32) Kwords
SA35-SA38	0111XXXXX	128 (4x32) Kwords
SA39-SA42	1000XXXXX	128 (4x32) Kwords
SA43-SA46	1001XXXXX	128 (4x32) Kwords
SA47-SA50	1010XXXXX	128 (4x32) Kwords
SA51-SA54	1011XXXXX	128 (4x32) Kwords
SA55-SA58	1100XXXXX	128 (4x32) Kwords
SA59-SA62	1101XXXXX	128 (4x32) Kwords
SA63-SA66	1110XXXXX	128 (4x32) Kwords
SA67	111100XXX	32 Kwords
SA68	111101XXX	32 Kwords
SA69	111110XXX	32 Kwords
SA70	111111000	4 Kwords
SA71	111111001	4 Kwords
SA72	111111010	4 Kwords
SA73	111111011	4 Kwords
SA74	111111100	4 Kwords
SA75	111111101	4 Kwords
SA76	111111110	4 Kwords
SA77	111111111	4 Kwords

Selecting a Sector Protection Mode

The device is shipped with all sectors unprotected. Optional Spansion programming services enable programming and protecting sectors at the factory prior to shipping the device. Contact your local sales office for details.

It is possible to determine whether a sector is protected or unprotected. See the Secured Silicon Sector Addresses for details.

Table I2. Sector Protection Schemes

DYB	PPB	PPB Lock	Sector State
0	0	0	Unprotected—PPB and DYB are changeable
0	0	1	Unprotected—PPB not changeable, DYB is changeable
0	1	0	Protected—PPB and DYB are changeable
1	0	0	
1	1	0	
0	1	1	Protected—PPB not changeable, DYB is changeable
1	0	1	
1	1	1	

Sector Protection

The PL127J, PL064J, and PL032J features several levels of sector protection, which can disable both the program and erase operations in certain sectors or sector groups.

Sector Protection Schemes

Password Sector Protection

A highly sophisticated protection method that requires a password before changes to certain sectors or sector groups are permitted

WP# Hardware Protection

A write protect pin that can prevent program or erase operations in sectors SA1-133, SA1-134, SA2-0 and SA2-1.

The WP# Hardware Protection feature is always available, independent of the software managed protection method chosen.

Selecting a Sector Protection Mode

All parts default to operate in the Persistent Sector Protection mode. The customer must then choose if the Persistent or Password Protection method is most desirable. There are two one-time programmable non-volatile bits that define which sector protection method will be used. If the Persistent Sector Protection method is desired, programming the Persistent Sector Protection Mode Locking Bit permanently sets the device to the Persistent Sector Protection mode. If the Password Sector Protection method is desired, programming the Password Mode Locking Bit permanently sets the device to the Password Sector Protection mode. It is not possible to switch between the two protection modes once a locking bit has been set. One of the two modes must be selected when the device is first programmed. This prevents a program or virus from later setting the Password Mode Locking Bit, which would cause an unexpected shift from the default Persistent Sector Protection Mode into the Password Protection Mode.

The device is shipped with all sectors unprotected. Optional Spansion programming services enable programming and protecting sectors at the factory prior to shipping the device. Contact your local sales office for details.

It is possible to determine whether a sector is protected or unprotected. See Autoselect Mode for details.

Persistent Sector Protection

The Persistent Sector Protection method replaces the 12 V controlled protection method in previous flash devices. This new method provides three different sector protection states:

- **Persistently Locked**—The sector is protected and cannot be changed.
- **Dynamically Locked**—The sector is protected and can be changed by a simple command.
- **Unlocked**—The sector is unprotected and can be changed by a simple command.

To achieve these states, three types of “bits” are used:

- Persistent Protection Bit
- Persistent Protection Bit Lock
- Persistent Sector Protection Mode Locking Bit

Persistent Protection Bit (PPB)

A single Persistent (non-volatile) Protection Bit is assigned to a maximum four sectors (see the sector address tables for specific sector protection groupings). All 4 Kword boot-block sectors have individual sector Persistent Protection Bits (PPBs) for greater flexibility. Each PPB is individually modifiable through the PPB Write Command.

The device erases all PPBs in parallel. If any PPB requires erasure, the device must be instructed to preprogram all of the sector PPBs prior to PPB erasure. Otherwise, a previously erased sector PPBs can potentially be over-erased. The flash device does not have a built-in means of preventing sector PPBs over-erasure.

Persistent Protection Bit Lock (PPB Lock)

The Persistent Protection Bit Lock (PPB Lock) is a global volatile bit. When set to “1”, the PPBs cannot be changed. When cleared (“0”), the PPBs are changeable. There is only one PPB Lock bit per device. The PPB Lock is cleared after power-up or hardware reset. There is no command sequence to unlock the PPB Lock.

Dynamic Protection Bit (DYB)

A volatile protection bit is assigned for each sector. After power-up or hardware reset, the contents of all DYBs is “0”. Each DYB is individually modifiable through the DYB Write Command.

When the parts are first shipped, the PPBs are cleared, the DYBs are cleared, and PPB Lock is defaulted to power up in the cleared state – meaning the PPBs are changeable.

When the device is first powered on the DYBs power up cleared (sectors not protected). The Protection State for each sector is determined by the logical OR of the PPB and the DYB related to that sector. For the sectors that have the PPBs cleared, the DYBs control whether or not the sector is protected or unprotected. By issuing the DYB Write command sequences, the DYBs will be set or cleared, thus placing each sector in the protected or unprotected state. These are the so-called Dynamic Locked or Unlocked states. They are called dynamic states because it is very easy to switch back and forth between the protected and unprotected conditions. This allows software to easily protect sectors against in-

advertent changes yet does not prevent the easy removal of protection when changes are needed. The DYBs maybe set or cleared as often as needed.

The PPBs allow for a more static, and difficult to change, level of protection. The PPBs retain their state across power cycles because they are non-volatile. Individual PPBs are set with a command but must all be cleared as a group through a complex sequence of program and erasing commands. The PPBs are also limited to 100 erase cycles.

The PPB Lock bit adds an additional level of protection. Once all PPBs are programmed to the desired settings, the PPB Lock may be set to "1". Setting the PPB Lock disables all program and erase commands to the non-volatile PPBs. In effect, the PPB Lock Bit locks the PPBs into their current state. The only way to clear the PPB Lock is to go through a power cycle. System boot code can determine if any changes to the PPB are needed; for example, to allow new system code to be downloaded. If no changes are needed then the boot code can set the PPB Lock to disable any further changes to the PPBs during system operation.

The WP#/ACC write protect pin adds a final level of hardware protection to sectors SA1-133, SA1-134, SA2-0 and SA2-1. When this pin is low it is not possible to change the contents of these sectors. These sectors generally hold system boot code. The WP#/ACC pin can prevent any changes to the boot code that could override the choices made while setting up sector protection during system initialization.

For customers who are concerned about malicious viruses there is another level of security - the persistently locked state. To persistently protect a given sector or sector group, the PPBs associated with that sector need to be set to "1". Once all PPBs are programmed to the desired settings, the PPB Lock should be set to "1". Setting the PPB Lock automatically disables all program and erase commands to the Non-Volatile PPBs. In effect, the PPB Lock "freezes" the PPBs into their current state. The only way to clear the PPB Lock is to go through a power cycle.

It is possible to have sectors that have been persistently locked, and sectors that are left in the dynamic state. The sectors in the dynamic state are all unprotected. If there is a need to protect some of them, a simple DYB Write command sequence is all that is necessary. The DYB write command for the dynamic sectors switch the DYBs to signify protected and unprotected, respectively. If there is a need to change the status of the persistently locked sectors, a few more steps are required. First, the PPB Lock bit must be disabled by either putting the device through a power-cycle, or hardware reset. The PPBs can then be changed to reflect the desired settings. Setting the PPB lock bit once again will lock the PPBs, and the device operates normally again.

The best protection is achieved by executing the PPB lock bit set command early in the boot code, and protect the boot code by holding WP#/ACC = VIL.

Table 12 contains all possible combinations of the DYB, PPB, and PPB lock relating to the status of the sector.

In summary, if the PPB is set, and the PPB lock is set, the sector is protected and the protection can not be removed until the next power cycle clears the PPB lock. If the PPB is cleared, the sector can be dynamically locked or unlocked. The DYB then controls whether or not the sector is protected or unprotected.

If the user attempts to program or erase a protected sector, the device ignores the command and returns to read mode. A program command to a protected sector enables status polling for approximately 1 μ s before the device returns to read

mode without having modified the contents of the protected sector. An erase command to a protected sector enables status polling for approximately 50 μ s after which the device returns to read mode without having erased the protected sector.

The programming of the DYB, PPB, and PPB lock for a given sector can be verified by writing a DYB/PPB/PPB lock verify command to the device. There is an alternative means of reading the protection status. Take RESET# to VIL and hold WE# at VIH. (The high voltage A9 Autoselect Mode also works for reading the status of the PPBs). Scanning the addresses (A18–A11) while (A6, A1, A0) = (0, 1, 0) will produce a logical "1" code at device output DQ0 for a protected sector or a "0" for an unprotected sector. In this mode, the other addresses are don't cares. Address location with A1 = VIL are reserved for autoselect manufacturer and device codes.

Persistent Sector Protection Mode Locking Bit

Like the password mode locking bit, a Persistent Sector Protection mode locking bit exists to guarantee that the device remain in software sector protection. Once set, the Persistent Sector Protection locking bit prevents programming of the password protection mode locking bit. This guarantees that a hacker could not place the device in password protection mode.

Password Protection Mode

The Password Sector Protection Mode method allows an even higher level of security than the Persistent Sector Protection Mode. There are two main differences between the Persistent Sector Protection and the Password Sector Protection Mode:

When the device is first powered on, or comes out of a reset cycle, the PPB Lock bit set to the locked state, rather than cleared to the unlocked state.

The only means to clear the PPB Lock bit is by writing a unique 64-bit Password to the device.

The Password Sector Protection method is otherwise identical to the Persistent Sector Protection method.

A 64-bit password is the only additional tool utilized in this method.

Once the Password Mode Locking Bit is set, the password is permanently set with no means to read, program, or erase it. The password is used to clear the PPB Lock bit. The Password Unlock command must be written to the flash, along with a password. The flash device internally compares the given password with the pre-programmed password. If they match, the PPB Lock bit is cleared, and the PPBs can be altered. If they do not match, the flash device does nothing. There is a built-in 2 μ s delay for each "password check." This delay is intended to thwart any efforts to run a program that tries all possible combinations in order to crack the password.

Password and Password Mode Locking Bit

In order to select the Password sector protection scheme, the customer must first program the password. The password may be correlated to the unique Electronic Serial Number (ESN) of the particular flash device. Each ESN is different for every flash device; therefore each password should be different for every flash device. While programming in the password region, the customer may perform Password Verify operations.

Once the desired password is programmed in, the customer must then set the Password Mode Locking Bit. This operation achieves two objectives:

Permanently sets the device to operate using the Password Protection Mode. It is not possible to reverse this function.

Disables all further commands to the password region. All program, and read operations are ignored.

Both of these objectives are important, and if not carefully considered, may lead to unrecoverable errors. The user must be sure that the Password Protection method is desired when setting the Password Mode Locking Bit. More importantly, the user must be sure that the password is correct when the Password Mode Locking Bit is set. Due to the fact that read operations are disabled, there is no means to verify what the password is afterwards. If the password is lost after setting the Password Mode Locking Bit, there will be no way to clear the PPB Lock bit.

The Password Mode Locking Bit, once set, prevents reading the 64-bit password on the DQ bus and further password programming. The Password Mode Locking Bit is not erasable. Once Password Mode Locking Bit is programmed, the Persistent Sector Protection Locking Bit is disabled from programming, guaranteeing that no changes to the protection scheme are allowed.

64-bit Password

The 64-bit Password is located in its own memory space and is accessible through the use of the Password Program and Verify commands (see "Password Verify Command"). The password function works in conjunction with the Password Mode Locking Bit, which when set, prevents the Password Verify command from reading the contents of the password on the pins of the device.

Write Protect (WP#)

The Write Protect feature provides a hardware method of protecting the upper two and lower two sectors without using V_{ID} . This function is provided by the WP# pin and overrides the previously discussed High Voltage Sector Protection method.

If the system asserts V_{IL} on the WP#/ACC pin, the device disables program and erase functions in the two outermost 4 Kword sectors on both ends of the flash array independent of whether it was previously protected or unprotected.

If the system asserts V_{IH} on the WP#/ACC pin, the device reverts the upper two and lower two sectors to whether they were last set to be protected or unprotected. That is, sector protection or unprotection for these sectors depends on whether they were last protected or unprotected using the method described in the High Voltage Sector Protection.

Note that the WP#/ACC pin must not be left floating or unconnected; inconsistent behavior of the device may result.

Persistent Protection Bit Lock

The Persistent Protection Bit (PPB) Lock is a volatile bit that reflects the state of the Password Mode Locking Bit after power-up reset. If the Password Mode Lock Bit is also set after a hardware reset (RESET# asserted) or a power-up reset, the ONLY means for clearing the PPB Lock Bit in Password Protection Mode is to issue the Password Unlock command. Successful execution of the Password Unlock command clears the PPB Lock Bit, allowing for sector PPBs modifications. Asserting RESET#, taking the device through a power-on reset, or issuing the PPB Lock

Bit Set command sets the PPB Lock Bit to a "1" when the Password Mode Lock Bit is not set.

If the Password Mode Locking Bit is not set, including Persistent Protection Mode, the PPB Lock Bit is cleared after power-up or hardware reset. The PPB Lock Bit is set by issuing the PPB Lock Bit Set command. Once set the only means for clearing the PPB Lock Bit is by issuing a hardware or power-up reset. The Password Unlock command is ignored in Persistent Protection Mode.

High Voltage Sector Protection

Sector protection and unprotection may also be implemented using programming equipment. The procedure requires high voltage (V_{ID}) to be placed on the RE-SET# pin. Refer to [Figure 1](#) for details on this procedure. Note that for sector unprotect, all unprotected sectors must first be protected prior to the first sector write cycle.

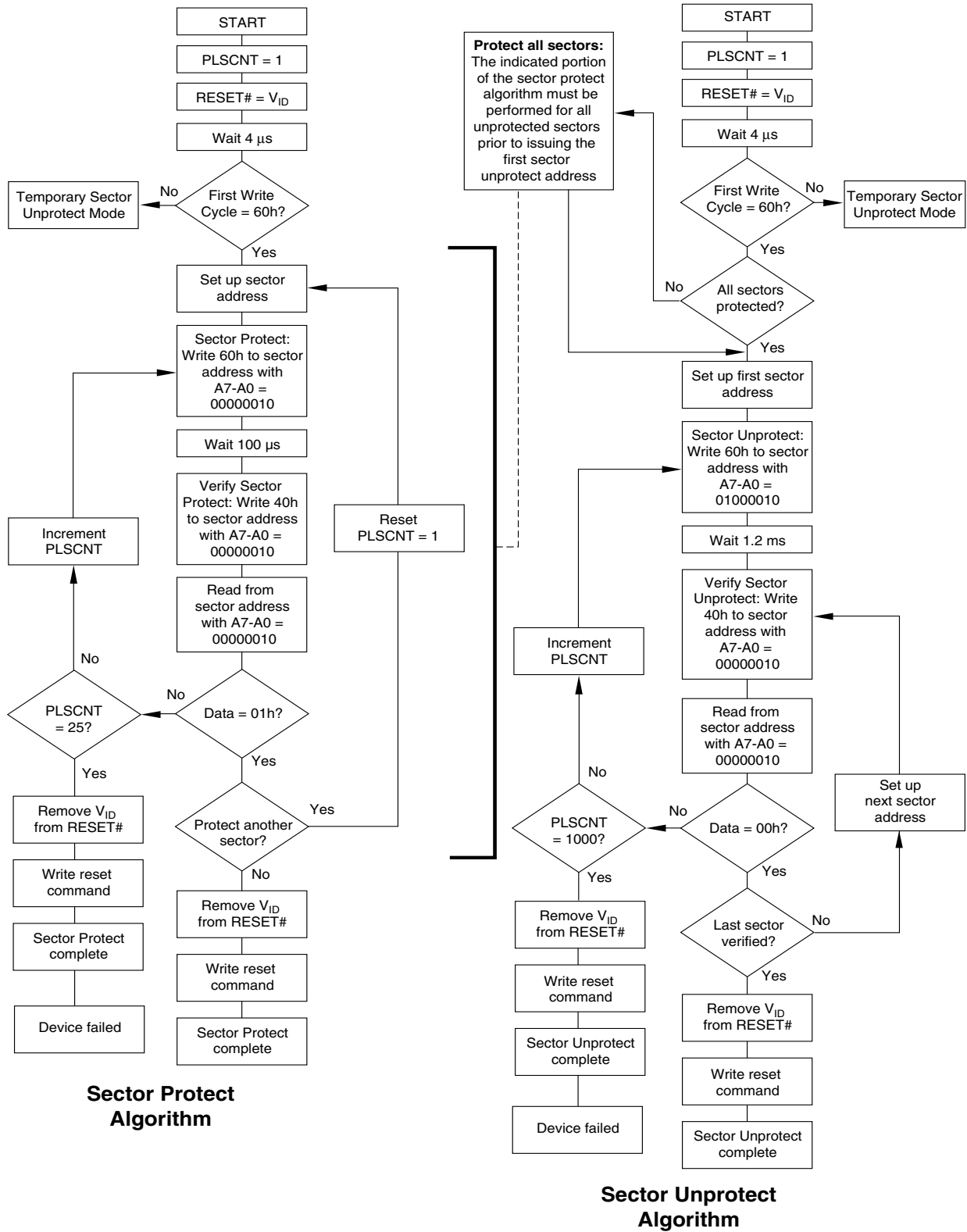
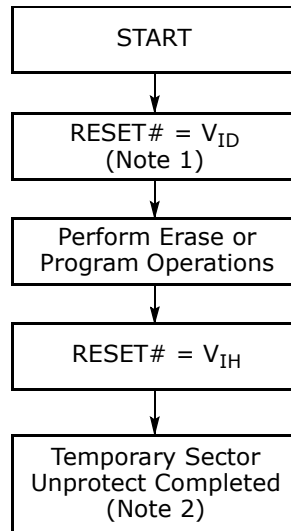

Figure 1.

Temporary Sector Unprotect

This feature allows temporary unprotection of previously protected sectors to change data in-system. The Sector Unprotect mode is activated by setting the RESET# pin to V_{ID} . During this mode, formerly protected sectors can be programmed or erased by selecting the sector addresses. Once V_{ID} is removed from the RESET# pin, all the previously protected sectors are protected again. 2 shows the algorithm, and 21 shows the timing diagrams, for this feature. While PPB lock is set, the device cannot enter the Temporary Sector Unprotection Mode.



Notes:

1. All protected sectors unprotected (If WP#/ACC = V_{IL} , upper two and lower two sectors will remain protected).
2. All previously protected sectors are protected once again

Figure 2.

Secured Silicon Sector Flash Memory Region

The Secured Silicon Sector feature provides a Flash memory region that enables permanent part identification through an Electronic Serial Number (ESN) The 128-word Secured Silicon sector is divided into 64 factory-lockable words that can be programmed and locked by the customer. The Secured Silicon sector is located at addresses 000000h-00007Fh in both Persistent Protection mode and Password Protection mode. It uses indicator bits (DQ6, DQ7) to indicate the factory-locked and customer-locked status of the part.

The system accesses the Secured Silicon Sector through a command sequence (see the Enter Secured Silicon Sector/Exit Secured Silicon Sector Command Sequence). After the system has written the Enter Secured Silicon Sector command sequence, it may read the Secured Silicon Sector by using the addresses normally occupied by the boot sectors. This mode of operation continues until the system issues the Exit Secured Silicon Sector command sequence, or until power is removed from the device. On power-up, or following a hardware reset, the device reverts to sending commands to the normal address space. *Note that the ACC function and unlock bypass modes are not available when the Secured Silicon Sector is enabled.*

Factory-Locked Area (64 words)

The factory-locked area of the Secured Silicon Sector (000000h-00003Fh) is locked when the part is shipped, whether or not the area was programmed at the factory. The Secured Silicon Sector Factory-locked Indicator Bit (DQ7) is permanently set to a "1". Optional Spansion programming services can program the factory-locked area with a random ESN, a customer-defined code, or any combination of the two. Because only Spansion can program and protect the factory-locked area, this method ensures the security of the ESN once the product is shipped to the field. Contact your local sales office for details on using Spansion's programming services. Note that the ACC function and unlock bypass modes are not available when the Secured Silicon sector is enabled.

Customer-Lockable Area (64 words)

The customer-lockable area of the Secured Silicon Sector (000040h-00007Fh) is shipped unprotected, which allows the customer to program and optionally lock the area as appropriate for the application. The Secured Silicon Sector Customer-locked Indicator Bit (DQ6) is shipped as "0" and can be permanently locked to "1" by issuing the Secured Silicon Protection Bit Program Command. The Secured Silicon Sector can be read any number of times, but can be programmed and locked only once. Note that the accelerated programming (ACC) and unlock bypass functions are not available when programming the Secured Silicon Sector.

The Customer-lockable Secured Silicon Sector area can be protected using one of the following procedures:

- Write the three-cycle Enter Secured Silicon Sector Region command sequence, and then follow the in-system sector protect algorithm as shown in [Figure 1](#), except that *RESET#* may be at either V_{IH} or V_{ID} . This allows in-system protection of the Secured Silicon Sector Region without raising any device pin to a high voltage. Note that this method is only applicable to the Secured Silicon Sector.
- To verify the protect/unprotect status of the Secured Silicon Sector, follow the algorithm shown in [Figure 3](#).

Once the Secured Silicon Sector is locked and verified, the system must write the Exit Secured Silicon Sector Region command sequence to return to reading and writing the remainder of the array.

The Secured Silicon Sector lock must be used with caution since, once locked, there is no procedure available for unlocking the Secured Silicon Sector area and none of the bits in the Secured Silicon Sector memory space can be modified in any way.

Secured Silicon Sector Protection Bits

The Secured Silicon Sector Protection Bits prevent programming of the Secured Silicon Sector memory area. Once set, the Secured Silicon Sector memory area contents are non-modifiable.

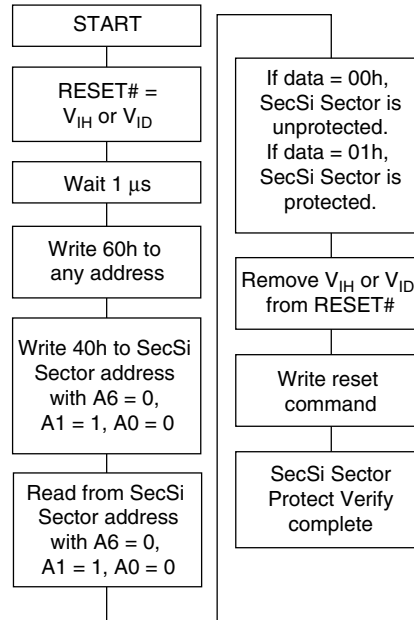

Figure 3. Secured Silicon Sector Protect Verify

Hardware Data Protection

The command sequence requirement of unlock cycles for programming or erasing provides data protection against inadvertent writes. In addition, the following hardware data protection measures prevent accidental erasure or programming, which might otherwise be caused by spurious system level signals during V_{CC} power-up and power-down transitions, or from system noise.

Low V_{CC} Write Inhibit

When V_{CC} is less than V_{LKO} , the device does not accept any write cycles. This protects data during V_{CC} power-up and power-down. The command register and all internal program/erase circuits are disabled, and the device resets to the read mode. Subsequent writes are ignored until V_{CC} is greater than V_{LKO} . The system must provide the proper signals to the control pins to prevent unintentional writes when V_{CC} is greater than V_{LKO} .

Write Pulse “Glitch” Protection

Noise pulses of less than 3 ns (typical) on OE#, CE#, or WE# do not initiate a write cycle.

Logical Inhibit

Write cycles are inhibited by holding any one of OE# = V_{IL} , CE# = V_{IH} or WE# = V_{IH} . To initiate a write cycle, CE# and WE# must be a logical zero while OE# is a logical one.

Power-Up Write Inhibit

If WE# = CE# = V_{IL} and OE# = V_{IH} during power up, the device does not accept commands on the rising edge of WE#. The internal state machine is automatically reset to the read mode on power-up.

Common Flash Memory Interface (CFI)

The Common Flash Interface (CFI) specification outlines device and host system software interrogation handshake, which allows specific vendor-specified software algorithms to be used for entire families of devices. Software support can then be device-independent, JEDEC ID-independent, and forward- and backward-compatible for the specified flash device families. Flash vendors can standardize their existing interfaces for long-term compatibility.

This device enters the CFI Query mode when the system writes the CFI Query command, 98h, to address 55h, any time the device is ready to read array data. The system can read CFI information at the addresses given in Tables 13–16. To terminate reading CFI data, the system must write the reset command. The CFI Query mode is not accessible when the device is executing an Embedded Program or embedded Erase algorithm.

The system can also write the CFI query command when the device is in the autoselect mode. The device enters the CFI query mode, and the system can read CFI data at the addresses given in Tables 13–16. The system must write the reset command to return the device to reading array data.

For further information, please refer to the CFI Specification and CFI Publication 100. Contact your local sales office for copies of these documents.

Table 13. CFI Query Identification String

Addresses	Data	Description
10h 11h 12h	0051h 0052h 0059h	Query Unique ASCII string "QRY"
13h 14h	0002h 0000h	Primary OEM Command Set
15h 16h	0040h 0000h	Address for Primary Extended Table
17h 18h	0000h 0000h	Alternate OEM Command Set (00h = none exists)
19h 1Ah	0000h 0000h	Address for Alternate OEM Extended Table (00h = none exists)

Table I4. System Interface String

Addresses	Data	Description
1Bh	0027h	V _{CC} Min. (write/erase) D7–D4: volt, D3–D0: 100 millivolt
1Ch	0036h	V _{CC} Max. (write/erase) D7–D4: volt, D3–D0: 100 millivolt
1Dh	0000h	V _{PP} Min. voltage (00h = no V _{PP} pin present)
1Eh	0000h	V _{PP} Max. voltage (00h = no V _{PP} pin present)
1Fh	0003h	Typical timeout per single byte/word write 2 ^N μs
20h	0000h	Typical timeout for Min. size buffer write 2 ^N μs (00h = not supported)
21h	0009h	Typical timeout per individual block erase 2 ^N ms
22h	0000h	Typical timeout for full chip erase 2 ^N ms (00h = not supported)
23h	0004h	Max. timeout for byte/word write 2 ^N times typical
24h	0000h	Max. timeout for buffer write 2 ^N times typical
25h	0004h	Max. timeout per individual block erase 2 ^N times typical
26h	0000h	Max. timeout for full chip erase 2 ^N times typical (00h = not supported)

Table I5. Device Geometry Definition

Addresses	Data	Description
27h	0018h (PL127J) 0017h (PL064J) 0016h (PL032J)	Device Size = 2 ^N byte
28h 29h	0001h 0000h	Flash Device Interface description (refer to CFI publication 100)
2Ah 2Bh	0000h 0000h	Max. number of byte in multi-byte write = 2 ^N (00h = not supported)
2Ch	0003h	Number of Erase Block Regions within device
2Dh 2Eh 2Fh 30h	0007h 0000h 0020h 0000h	Erase Block Region 1 Information (refer to the CFI specification or CFI publication 100)
31h	00FDh (PL127J) 007Dh (PL064J) 003Dh (PL032J)	Erase Block Region 2 Information (refer to the CFI specification or CFI publication 100)
32h 33h 34h	0000h 0000h 0001h	
35h 36h 37h 38h	0007h 0000h 0020h 0000h	Erase Block Region 3 Information (refer to the CFI specification or CFI publication 100)
39h 3Ah 3Bh 3Ch	0000h 0000h 0000h 0000h	Erase Block Region 4 Information (refer to the CFI specification or CFI publication 100)

Table 16. Primary Vendor-Specific Extended Query

Addresses	Data	Description
40h 41h 42h	0050h 0052h 0049h	Query-unique ASCII string "PRI"
43h	0031h	Major version number, ASCII (reflects modifications to the silicon)
44h	0033h	Minor version number, ASCII (reflects modifications to the CFI table)
45h	TBD	Address Sensitive Unlock (Bits 1-0) 0 = Required, 1 = Not Required Silicon Revision Number (Bits 7-2)
46h	0002h	Erase Suspend 0 = Not Supported, 1 = To Read Only, 2 = To Read & Write
47h	0001h	Sector Protect 0 = Not Supported, X = Number of sectors in per group
48h	0001h	Sector Temporary Unprotect 00 = Not Supported, 01 = Supported
49h	0007h (PLxxxJ)	Sector Protect/Unprotect scheme 07 = Advanced Sector Protection
4Ah	00E7h (PL127J) 0077h (PL064J) 003Fh (PL032J)	Simultaneous Operation 00 = Not Supported, X = Number of Sectors excluding Bank 1
4Bh	0000h	Burst Mode Type 00 = Not Supported, 01 = Supported
4Ch	0002h (PLxxxJ)	Page Mode Type 00 = Not Supported, 01 = 4 Word Page, 02 = 8 Word Page
4Dh	0085h	ACC (Acceleration) Supply Minimum 00h = Not Supported, D7-D4: Volt, D3-D0: 100 mV
4Eh	0095h	ACC (Acceleration) Supply Maximum 00h = Not Supported, D7-D4: Volt, D3-D0: 100 mV
4Fh	0001h	Top/Bottom Boot Sector Flag 00h = Uniform device, 01h = Both top and bottom boot with write protect, 02h = Bottom Boot Device, 03h = Top Boot Device, 04h = Both Top and Bottom
50h	0001h	Program Suspend 0 = Not supported, 1 = Supported
57h	0004h	Bank Organization 00 = Data at 4Ah is zero, X = Number of Banks
58h	0027h (PL127J) 0017h (PL064J) 000Fh (PL032J)	Bank 1 Region Information X = Number of Sectors in Bank 1
59h	0060h (PL127J) 0030h (PL064J) 0018h (PL032J)	Bank 2 Region Information X = Number of Sectors in Bank 2
5Ah	0060h (PL127J) 0030h (PL064J) 0018h (PL032J)	Bank 3 Region Information X = Number of Sectors in Bank 3

Table 16. Primary Vendor-Specific Extended Query (Continued)

Addresses	Data	Description
5Bh	0027h (PL127J) 0017h (PL064J) 000Fh (PL032J)	Bank 4 Region Information X = Number of Sectors in Bank 4

Command Definitions

Writing specific address and data commands or sequences into the command register initiates device operations. Table 17 defines the valid register command sequences. Writing **incorrect address and data values** or writing them in the **improper sequence** may place the device in an unknown state. A reset command is then required to return the device to reading array data.

All addresses are latched on the falling edge of WE# or CE#, whichever happens later. All data is latched on the rising edge of WE# or CE#, whichever happens first. Refer to the AC Characteristic section for timing diagrams.

Reading Array Data

The device is automatically set to reading array data after device power-up. No commands are required to retrieve data. Each bank is ready to read array data after completing an Embedded Program or Embedded Erase algorithm.

After the device accepts an Erase Suspend command, the corresponding bank enters the erase-suspend-read mode, after which the system can read data from any non-erase-suspended sector within the same bank. The system can read array data using the standard read timing, except that if it reads at an address within erase-suspended sectors, the device outputs status data. After completing a programming operation in the Erase Suspend mode, the system may once again read array data with the same exception. See the Erase Suspend/Erase Resume Commands section for more information.

The system *must* issue the reset command to return a bank to the read (or erase-suspend-read) mode if DQ5 goes high during an active program or erase operation, or if the bank is in the autoselect mode. See the next section, Reset Command, for more information.

See also Requirements for Reading Array Data in the Device Bus Operations section for more information. The AC Characteristic table provides the read parameters, and Figure 12 shows the timing diagram.

Reset Command

Writing the reset command resets the banks to the read or erase-suspend-read mode. Address bits are don't cares for this command.

The reset command may be written between the sequence cycles in an erase command sequence before erasing begins. This resets the bank to which the system was writing to the read mode. Once erasure begins, however, the device ignores reset commands until the operation is complete.

The reset command may be written between the sequence cycles in a program command sequence before programming begins. This resets the bank to which the system was writing to the read mode. If the program command sequence is written to a bank that is in the Erase Suspend mode, writing the reset command returns that bank to the erase-suspend-read mode. Once programming begins, however, the device ignores reset commands until the operation is complete.

The reset command may be written between the sequence cycles in an autoselect command sequence. Once in the autoselect mode, the reset command must be written to return to the read mode. If a bank entered the autoselect mode while in the Erase Suspend mode, writing the reset command returns that bank to the erase-suspend-read mode.

If DQ5 goes high during a program or erase operation, writing the reset command returns the banks to the read mode (or erase-suspend-read mode if that bank was in Erase Suspend).

Autoselect Command Sequence

The autoselect command sequence allows the host system to access the manufacturer and device codes, and determine whether or not a sector is protected. The autoselect command sequence may be written to an address within a bank that is either in the read or erase-suspend-read mode. The autoselect command may not be written while the device is actively programming or erasing in the other bank.

The autoselect command sequence is initiated by first writing two unlock cycles. This is followed by a third write cycle that contains the bank address and the autoselect command. The bank then enters the autoselect mode. The system may read any number of autoselect codes without reinitiating the command sequence.

Table 17 shows the address and data requirements. To determine sector protection information, the system must write to the appropriate bank address (BA) and sector address (SA). Table 3 shows the address range and bank number associated with each sector.

The system must write the reset command to return to the read mode (or erase-suspend-read mode if the bank was previously in Erase Suspend).

Enter Secured Silicon Sector/Exit Secured Silicon Sector Command Sequence

The Secured Silicon Sector region provides a secured data area containing a random, eight word electronic serial number (ESN). The system can access the Secured Silicon Sector region by issuing the three-cycle Enter Secured Silicon Sector command sequence. The device continues to access the Secured Silicon Sector region until the system issues the four-cycle Exit Secured Silicon Sector command sequence. The Exit Secured Silicon Sector command sequence returns the device to normal operation. The Secured Silicon Sector is not accessible when the device is executing an Embedded Program or embedded Erase algorithm. Table 17 shows the address and data requirements for both command sequences. See also "Secured Silicon Sector Flash Memory Region" for further information. *Note that the ACC function and unlock bypass modes are not available when the Secured Silicon Sector is enabled.*

Word Program Command Sequence

Programming is a four-bus-cycle operation. The program command sequence is initiated by writing two unlock write cycles, followed by the program set-up command. The program address and data are written next, which in turn initiate the Embedded Program algorithm. The system is *not* required to provide further controls or timings. The device automatically provides internally generated program pulses and verifies the programmed cell margin. Table 17 shows the address and data requirements for the program command sequence. *Note that the Secured*

Silicon Sector, autoselect, and CFI functions are unavailable when a [program/erase] operation is in progress.

When the Embedded Program algorithm is complete, that bank then returns to the read mode and addresses are no longer latched. The system can determine the status of the program operation by using DQ7, DQ6, or RY/BY#. Refer to the Write Operation Status section for information on these status bits.

Any commands written to the device during the Embedded Program Algorithm are ignored. Note that a **hardware reset** immediately terminates the program operation. The program command sequence should be reinitiated once that bank has returned to the read mode, to ensure data integrity. Note that the Secured Silicon Sector, autoselect and CFI functions are unavailable when the Secured Silicon Sector is enabled.

Programming is allowed in any sequence and across sector boundaries. **A bit cannot be programmed from "0" back to a "1."** Attempting to do so may cause that bank to set DQ5 = 1, or cause the DQ7 and DQ6 status bits to indicate the operation was successful. However, a succeeding read will show that the data is still "0." Only erase operations can convert a "0" to a "1."

Unlock Bypass Command Sequence

The unlock bypass feature allows the system to program data to a bank faster than using the standard program command sequence. The unlock bypass command sequence is initiated by first writing two unlock cycles. This is followed by a third write cycle containing the unlock bypass command, 20h. That bank then enters the unlock bypass mode. A two-cycle unlock bypass program command sequence is all that is required to program in this mode. The first cycle in this sequence contains the unlock bypass program command, A0h; the second cycle contains the program address and data. Additional data is programmed in the same manner. This mode dispenses with the initial two unlock cycles required in the standard program command sequence, resulting in faster total programming time. Table 17 shows the requirements for the command sequence.

During the unlock bypass mode, only the Unlock Bypass Program and Unlock Bypass Reset commands are valid. To exit the unlock bypass mode, the system must issue the two-cycle unlock bypass reset command sequence. (See Table 18)

The device offers accelerated program operations through the WP#/ACC pin. When the system asserts V_{HH} on the WP#/ACC pin, the device automatically enters the Unlock Bypass mode. The system may then write the two-cycle Unlock Bypass program command sequence. The device uses the higher voltage on the WP#/ACC pin to accelerate the operation. *Note that the WP#/ACC pin must not be at V_{HH} any operation other than accelerated programming, or device damage may result. In addition, the WP#/ACC pin must not be left floating or unconnected; inconsistent behavior of the device may result.*

4 illustrates the algorithm for the program operation. Refer to the Erase/Program Operations table in the AC Characteristics section for parameters, and Figure 14 for timing diagrams.

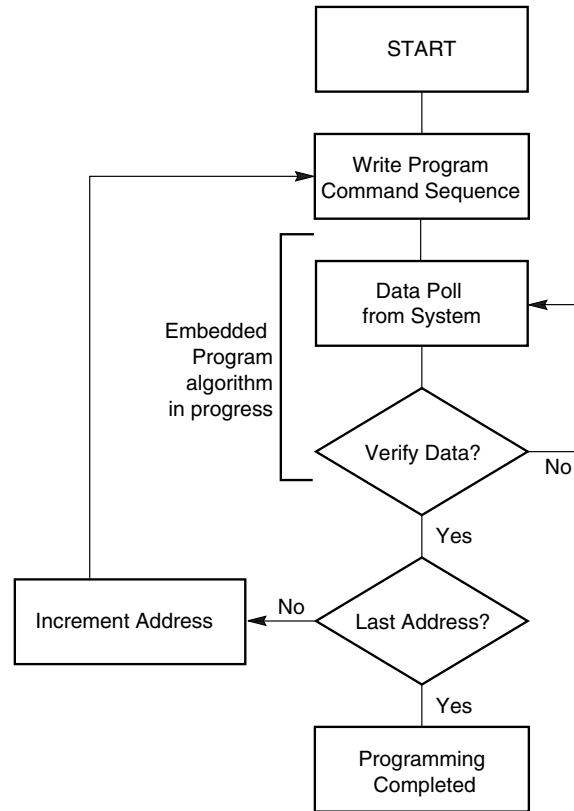

Note: See [reference] for program command sequence.

Figure 4. Program Operation

Chip Erase Command Sequence

Chip erase is a six bus cycle operation. The chip erase command sequence is initiated by writing two unlock cycles, followed by a set-up command. Two additional unlock write cycles are then followed by the chip erase command, which in turn invokes the Embedded Erase algorithm. The device does *not* require the system to preprogram prior to erase. The Embedded Erase algorithm automatically preprograms and verifies the entire memory for an all zero data pattern prior to electrical erase. The system is not required to provide any controls or timings during these operations. Table 17 shows the address and data requirements for the chip erase command sequence.

When the Embedded Erase algorithm is complete, that bank returns to the read mode and addresses are no longer latched. The system can determine the status of the erase operation by using DQ7, DQ6, DQ2, or RY/BY#. Refer to the Write Operation Status section for information on these status bits.

Any commands written during the chip erase operation are ignored. *Note that Secured Silicon Sector, autoselect, and CFI functions are unavailable when a [program/erase] operation is in progress.* However, note that a **hardware reset** immediately terminates the erase operation. If that occurs, the chip erase command sequence should be reinitiated once that bank has returned to reading array data, to ensure data integrity.

5 illustrates the algorithm for the erase operation. Refer to the Erase/Program Operations tables in the AC Characteristics section for parameters, and [Figure 16](#) section for timing diagrams.

Sector Erase Command Sequence

Sector erase is a six bus cycle operation. The sector erase command sequence is initiated by writing two unlock cycles, followed by a set-up command. Two additional unlock cycles are written, and are then followed by the address of the sector to be erased, and the sector erase command. Table 17 shows the address and data requirements for the sector erase command sequence.

The device does *not* require the system to preprogram prior to erase. The Embedded Erase algorithm automatically programs and verifies the entire memory for an all zero data pattern prior to electrical erase. The system is not required to provide any controls or timings during these operations.

After the command sequence is written, a sector erase time-out of 50 μ s occurs. During the time-out period, additional sector addresses and sector erase commands may be written. Loading the sector erase buffer may be done in any sequence, and the number of sectors may be from one sector to all sectors. The time between these additional cycles must be less than 50 μ s, otherwise erasure may begin. Any sector erase address and command following the exceeded time-out may or may not be accepted. It is recommended that processor interrupts be disabled during this time to ensure all commands are accepted. The interrupts can be re-enabled after the last Sector Erase command is written. **Any command other than Sector Erase or Erase Suspend during the time-out period resets that bank to the read mode.** The system must rewrite the command sequence and any additional addresses and commands. *Note that Secured Silicon Sector, autoselect, and CFI functions are unavailable when a [program/erase] operation is in progress.*

The system can monitor DQ3 to determine if the sector erase timer has timed out (See the section on DQ3: Sector Erase Timer). The time-out begins from the rising edge of the final WE# pulse in the command sequence.

When the Embedded Erase algorithm is complete, the bank returns to reading array data and addresses are no longer latched. Note that while the Embedded Erase operation is in progress, the system can read data from the non-erasing bank. The system can determine the status of the erase operation by reading DQ7, DQ6, DQ2, or RY/BY# in the erasing bank. Refer to the Write Operation Status section for information on these status bits.

Once the sector erase operation has begun, only the Erase Suspend command is valid. All other commands are ignored. However, note that a **hardware reset** immediately terminates the erase operation. If that occurs, the sector erase command sequence should be reinitiated once that bank has returned to reading array data, to ensure data integrity.

5 illustrates the algorithm for the erase operation. Refer to the Erase/Program Operations tables in the AC Characteristics section for parameters, and [Figure 16](#) section for timing diagrams.

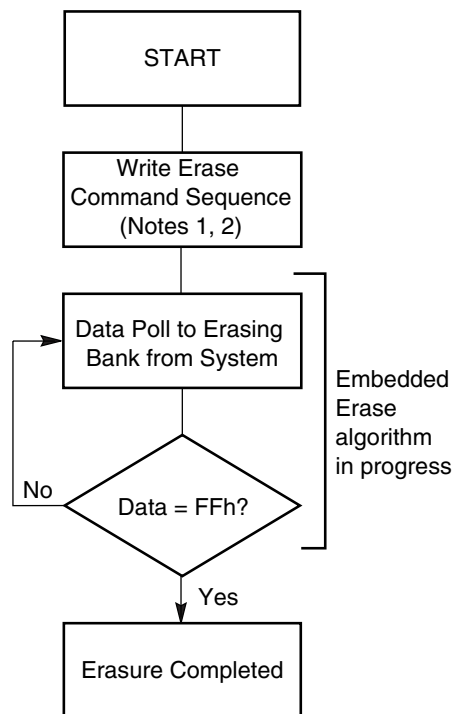
**Notes:**

1. See Table 17 for erase command sequence.
2. See the section on DQ3 for information on the sector erase timer.

Figure 5. Erase Operation**Erase Suspend/Erasure Resume Commands**

The Erase Suspend command, B0h, allows the system to interrupt a sector erase operation and then read data from, or program data to, any sector not selected for erasure. The bank address is required when writing this command. This command is valid only during the sector erase operation, including the 80 μ s time-out period during the sector erase command sequence. The Erase Suspend command is ignored if written during the chip erase operation or Embedded Program algorithm.

When the Erase Suspend command is written during the sector erase operation, the device requires a maximum of 35 μ s to suspend the erase operation. However, when the Erase Suspend command is written during the sector erase time-out, the device immediately terminates the time-out period and suspends the erase operation. Addresses are "don't-cares" when writing the Erase suspend command.

After the erase operation has been suspended, the bank enters the erase-suspend-read mode. The system can read data from or program data to any sector not selected for erasure. (The device "erase suspends" all sectors selected for erasure.) Reading at any address within erase-suspended sectors produces status information on DQ7–DQ0. The system can use DQ7, or DQ6 and DQ2 together, to determine if a sector is actively erasing or is erase-suspended. Refer to the Write Operation Status section for information on these status bits.

After an erase-suspended program operation is complete, the bank returns to the erase-suspend-read mode. The system can determine the status of the program

operation using the DQ7 or DQ6 status bits, just as in the standard Word Program operation. Refer to the Write Operation Status section for more information.

In the erase-suspend-read mode, the system can also issue the autoselect command sequence. The device allows reading autoselect codes even at addresses within erasing sectors, since the codes are not stored in the memory array. When the device exits the autoselect mode, the device reverts to the Erase Suspend mode, and is ready for another valid operation. Refer to the Secured Silicon Sector Addresses and the Autoselect Command Sequence sections for details.

To resume the sector erase operation, the system must write the Erase Resume command (address bits are don't care). The bank address of the erase-suspended bank is required when writing this command. Further writes of the Resume command are ignored. Another Erase Suspend command can be written after the chip has resumed erasing.

If the Persistent Sector Protection Mode Locking Bit is verified as programmed without margin, the Persistent Sector Protection Mode Locking Bit Program Command should be reissued to improve program margin. If the Secured Silicon Sector Protection Bit is verified as programmed without margin, the Secured Silicon Sector Protection Bit Program Command should be reissued to improve program margin. After programming a PPB, two additional cycles are needed to determine whether the PPB has been programmed with margin. If the PPB has been programmed without margin, the program command should be reissued to improve the program margin. Also note that the total number of PPB program/erase cycles is limited to 100 cycles. Cycling the PPBs beyond 100 cycles is not guaranteed.

After erasing the PPBs, two additional cycles are needed to determine whether the PPB has been erased with margin. If the PPBs has been erased without margin, the erase command should be reissued to improve the program margin. The programming of either the PPB or DYB for a given sector or sector group can be verified by writing a Sector Protection Status command to the device.

Note that there is no single command to independently verify the programming of a DYB for a given sector group.

Command Definitions Tables

Table 17. Memory Array Command Definitions

Command (Notes)	Cycles	Bus Cycles (Notes 1-4)												
		Addr	Data	Addr	Data	Addr	Data	Addr	Data	Addr	Data	Addr	Data	
Read (Note 5)	1	RA	RD											
Reset (Note 6)	1	XXX	F0											
Autoselect (Note 7)	Manufacturer ID	4	555	AA	2AA	55	(BA) 555	90	(BA) X00	01				
	Device ID (Note 10)	6	555	AA	2AA	55	(BA) 555	90	(BA) X01	227E	(BA) X0E	(Note 10)	(BA) X0F	(Note 10)
	Secured Silicon Sector Factory Protect (Note 8)	4	555	AA	2AA	55	(BA) 555	90	X03	(Note 8)				
	Sector Group Protect Verify (Note 9)	4	555	AAA	2AA	55	(BA) 555	90	(SA) X02	XX00/XX01				
Program	4	555	AA	2AA	55	555	A0	PA	PD					
Chip Erase	6	555	AA	2AA	55	555	80	555	AA	2AA	55	555	10	
Sector Erase	6	555	AA	2AA	55	555	80	555	AA	2AA	55	SA	30	
Program/Erase Suspend (Note 11)	1	BA	B0											

Table I7. Memory Array Command Definitions

Command (Notes)	Cycles	Bus Cycles (Notes 1-4)											
		Addr	Data	Addr	Data	Addr	Data	Addr	Data	Addr	Data	Addr	Data
Program/Erase Resume (Note 12)	1	BA	30										
CFI Query (Note 13)	1	55	98										
Accelerated Program (Note 15)	2	XX	A0	PA	PD								
Unlock Bypass Entry (Note 15)	3	555	AA	2AA	55	555	20						
Unlock Bypass Program (Note 15)	2	XX	A0	PA	PD								
Unlock Bypass Erase (Note 15)	2	XX	80	XX	10								
Unlock Bypass CFI (Notes 13, 15)	1	XX	98										
Unlock Bypass Reset (Note 15)	2	XXX	90	XXX	00								

Legend:

BA = Address of bank switching to autoselect mode, bypass mode, or erase operation. Determined by PL127J: Amax:A20, PL064J: Amax:A19, PL032J: Amax:A18.
 PA = Program Address (Amax:A0). Addresses latch on falling edge of WE# or CE# pulse, whichever happens later.
 PD = Program Data (DQ15:DQ0) written to location PA. Data latches on rising edge of WE# or CE# pulse, whichever happens first.

RA = Read Address (Amax:A0).

RD = Read Data (DQ15:DQ0) from location RA.

SA = Sector Address (Amax:A12) for verifying (in autoselect mode) or erasing.

WD = Write Data. See "Configuration Register" definition for specific write data. Data latched on rising edge of WE#.

X = Don't care

Notes:

- See Table 1 for description of bus operations.
- All values are in hexadecimal.
- Shaded cells in table denote read cycles. All other cycles are write operations.
- During unlock and command cycles, when lower address bits are 555 or 2AAh as shown in table, address bits higher than A11 (except where BA is required) and data bits higher than DQ7 are don't cares.
- No unlock or command cycles required when bank is reading array data.
- The Reset command is required to return to reading array (or to erase-suspend-read mode if previously in Erase Suspend) when bank is in autoselect mode, or if DQ5 goes high (while bank is providing status information).
- Fourth cycle of autoselect command sequence is a read cycle. System must provide bank address to obtain manufacturer ID or device ID information. See Autoselect Command Sequence for more information.
- The data is C4h for factory and customer locked, 84h for factory locked and 04h for not locked.
- The data is 00h for an unprotected sector group and 01h for a protected sector group.
- Device ID must be read across cycles 4, 5, and 6. PL127J (X0Eh = 2220h, X0Fh = 2200h), PL064J (X0Eh = 2202h, X0Fh = 2201h), PL032J (X0Eh = 220Ah, X0Fh = 2201h).
- System may read and program in non-erasing sectors, or enter autoselect mode, when in Program/Erase Suspend mode. Program/Erase Suspend command is valid only during a sector erase operation, and requires bank address.
- Program/Erase Resume command is valid only during Erase Suspend mode, and requires bank address.
- Command is valid when device is ready to read array data or when device is in autoselect mode.
- must be at V_{TD} during the entire operation of command.
- Unlock Bypass Entry command is required prior to any Unlock Bypass operation. Unlock Bypass Reset command is required to return to the reading array.

Table I8. Sector Protection Command Definitions

Command (Notes)	Cycles	Bus Cycles (Notes 1-4)													
		Addr	Data	Addr	Data	Addr	Data	Addr	Data	Addr	Data	Addr	Data	Addr	Data
Reset	1	XXX	F0												
Secured Silicon Sector Entry	3	555	AA	2AA	55	555	88								
Secured Silicon Sector Exit	4	555	AA	2AA	55	555	90	XX	00						
Secured Silicon Protection Bit Program (Notes 5, 6)	6	555	AA	2AA	55	555	60	OW	68	OW	48	OW	RD(0)		
Secured Silicon Protection Bit Status	5	555	AA	2AA	55	555	60	OW	48	OW	RD(0)				
Password Program (Notes 5, 7, 8)	4	555	AA	2AA	55	555	38	XX[0-3]	PD[0-3]						

Table 18. Sector Protection Command Definitions

Password Verify (Notes 6, 8, 9)	4	555	AA	2AA	55	555	C8	PWA[0-3]	PWD[0-3]						
Password Unlock (Notes 7, 10, 11)	7	555	AA	2AA	55	555	28	PWA[0]	PWD[0]	PWA[1]	PWD[1]	PWA[2]	PWD[2]	PWA[3]	PWD[3]
PPB Program (Notes 5, 6, 12)	6	555	AA	2AA	55	555	60	(SA)WP	68	(SA)WP	48	(SA)WP	RD(0)		
PPB Status	4	555	AA	2AA	55	555	90	(SA)WP	RD(0)						
All PPB Erase (Notes 5, 6, 13, 14)	6	555	AA	2AA	55	555	60	WP	60	(SA)	40	(SA)WP	RD(0)		
PPB Lock Bit Set	3	555	AA	2AA	55	555	78								
PPB Lock Bit Status (Note 15)	4	555	AA	2AA	55	555	58	SA	RD(1)						
DYB Write (Note 7)	4	555	AA	2AA	55	555	48	SA	X1						
DYB Erase (Note 7)	4	555	AA	2AA	55	555	48	SA	X0						
DYB Status (Note 6)	4	555	AA	2AA	55	555	58	SA	RD(0)						
PPMLB Program (Notes 5, 6, 12)	6	555	AA	2AA	55	555	60	PL	68	PL	48	PL	RD(0)		
PPMLB Status (Note 5)	5	555	AA	2AA	55	555	60	PL	48	PL	RD(0)				
SPMLB Program (Notes 5, 6, 12)	6	555	AA	2AA	55	555	60	SL	68	SL	48	SL	RD(0)		
SPMLB Status (Note 5)	5	555	AA	2AA	55	555	60	SL	48	SL	RD(0)				

Legend:

DYB = Dynamic Protection Bit
 OW = Address (A7:A0) is (00011010)
 PD[3:0] = Password Data (1 of 4 portions)
 PPB = Persistent Protection Bit
 PWA = Password Address. A1:A0 selects portion of password.
 PWD = Password Data being verified.
 PL = Password Protection Mode Lock Address (A7:A0) is (00001010)

RD(0) = Read Data DQ0 for protection indicator bit.
 RD(1) = Read Data DQ1 for PPB Lock status.
 SA = Sector Address where security command applies. Address bits Amax:A12 uniquely select any sector.
 SL = Persistent Protection Mode Lock Address (A7:A0) is (00010010)
 WP = PPB Address (A7:A0) is (00000010)
 X = Don't care
 PPMLB = Password Protection Mode Locking Bit
 SPMLB = Persistent Protection Mode Locking Bit

Notes:

- See Table 1 for description of bus operations.
- All values are in hexadecimal.
- Shaded cells in table denote read cycles. All other cycles are write operations.
- During unlock and command cycles, when lower address bits are 555 or 2AAh as shown in table, address bits higher than A11 (except where BA is required) and data bits higher than DQ7 are don't cares.
- The reset command returns device to reading array.
- Cycle 4 programs the addressed locking bit. Cycles 5 and 6 validate bit has been fully programmed when DQ0 = 1. If DQ0 = 0 in cycle 6, program command must be issued and verified again.
- Data is latched on the rising edge of WE#.
- Entire command sequence must be entered for each portion of password.
- Command sequence returns FFh if PPMLB is set.
- The password is written over four consecutive cycles, at addresses 0-3.
- A 2 μs timeout is required between any two portions of password.
- A 100 μs timeout is required between cycles 4 and 5.
- A 1.2 ms timeout is required between cycles 4 and 5.
- Cycle 4 erases all PPBs. Cycles 5 and 6 validate bits have been fully erased when DQ0 = 0. If DQ0 = 1 in cycle 6, erase command must be issued and verified again. Before issuing erase command, all PPBs should be programmed to prevent PPB overerase.
- DQ1 = 1 if PPB locked, 0 if unlocked.

Write Operation Status

The device provides several bits to determine the status of a program or erase operation: DQ2, DQ3, DQ5, DQ6, and DQ7. Table 19 and the following subsections describe the function of these bits. DQ7 and DQ6 each offer a method for determining whether a program or erase operation is complete or in progress. The device also provides a

hardware-based output signal, RY/BY#, to determine whether an Embedded Program or Erase operation is in progress or has been completed.

DQ7: Data# Polling

The Data# Polling bit, DQ7, indicates to the host system whether an Embedded Program or Erase algorithm is in progress or completed, or whether a bank is in Erase Suspend. Data# Polling is valid after the rising edge of the final WE# pulse in the command sequence.

During the Embedded Program algorithm, the device outputs on DQ7 the complement of the datum programmed to DQ7. This DQ7 status also applies to programming during Erase Suspend. When the Embedded Program algorithm is complete, the device outputs the datum programmed to DQ7. The system must provide the program address to read valid status information on DQ7. If a program address falls within a protected sector, Data# Polling on DQ7 is active for approximately 1 μ s, then that bank returns to the read mode.

During the Embedded Erase algorithm, Data# Polling produces a "0" on DQ7. When the Embedded Erase algorithm is complete, or if the bank enters the Erase Suspend mode, Data# Polling produces a "1" on DQ7. The system must provide an address within any of the sectors selected for erasure to read valid status information on DQ7.

After an erase command sequence is written, if all sectors selected for erasing are protected, Data# Polling on DQ7 is active for approximately 400 μ s, then the bank returns to the read mode. If not all selected sectors are protected, the Embedded Erase algorithm erases the unprotected sectors, and ignores the selected sectors that are protected. However, if the system reads DQ7 at an address within a protected sector, the status may not be valid.

When the system detects DQ7 has changed from the complement to true data, it can read valid data at DQ15–DQ0 on the *following* read cycles. Just prior to the completion of an Embedded Program or Erase operation, DQ7 may change asynchronously with DQ15–DQ0 while Output Enable (OE#) is asserted low. That is, the device may change from providing status information to valid data on DQ7. Depending on when the system samples the DQ7 output, it may read the status or valid data. Even if the device has completed the program or erase operation and DQ7 has valid data, the data outputs on DQ15–DQ0 may be still invalid. Valid data on DQ15–DQ0 will appear on successive read cycles.

Table 19 shows the outputs for Data# Polling on DQ7. 6 shows the Data# Polling algorithm. 18 in the AC Characteristic section shows the Data# Polling timing diagram.

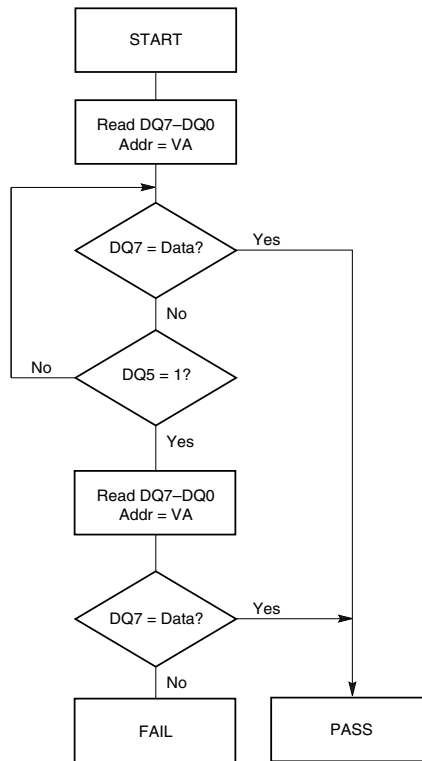

Notes:

1. VA = Valid address for programming. During a sector erase operation, a valid address is any sector address within the sector being erased. During chip erase, a valid address is any non-protected sector address.
2. DQ7 should be rechecked even if DQ5 = "1" because DQ7 may change simultaneously with DQ5.

Figure 6. Data# Polling Algorithm

RY/BY#: Ready/Busy#

The RY/BY# is a dedicated, open-drain output pin which indicates whether an Embedded Algorithm is in progress or complete. The RY/BY# status is valid after the rising edge of the final WE# pulse in the command sequence. Since RY/BY# is an open-drain output, several RY/BY# pins can be tied together in parallel with a pull-up resistor to V_{CC}.

If the output is low (Busy), the device is actively erasing or programming. (This includes programming in the Erase Suspend mode.) If the output is high (Ready), the device is in the read mode, the standby mode, or one of the banks is in the erase-suspend-read mode.

Table 19 shows the outputs for RY/BY#.

DQ6: Toggle Bit I

Toggle Bit I on DQ6 indicates whether an Embedded Program or Erase algorithm is in progress or complete, or whether the device has entered the Erase Suspend mode. Toggle Bit I may be read at any address, and is valid after the rising edge

of the final WE# pulse in the command sequence (prior to the program or erase operation), and during the sector erase time-out.

During an Embedded Program or Erase algorithm operation, successive read cycles to any address cause DQ6 to toggle. The system may use either OE# or CE# to control the read cycles. When the operation is complete, DQ6 stops toggling.

After an erase command sequence is written, if all sectors selected for erasing are protected, DQ6 toggles for approximately 400 μ s, then returns to reading array data. If not all selected sectors are protected, the Embedded Erase algorithm erases the unprotected sectors, and ignores the selected sectors that are protected.

The system can use DQ6 and DQ2 together to determine whether a sector is actively erasing or is erase-suspended. When the device is actively erasing (that is, the Embedded Erase algorithm is in progress), DQ6 toggles. When the device enters the Erase Suspend mode, DQ6 stops toggling. However, the system must also use DQ2 to determine which sectors are erasing or erase-suspended. Alternatively, the system can use DQ7 (see the DQ7: Data# Polling).

If a program address falls within a protected sector, DQ6 toggles for approximately 1 μ s after the program command sequence is written, then returns to reading array data.

DQ6 also toggles during the erase-suspend-program mode, and stops toggling once the Embedded Program algorithm is complete.

Table 19 shows the outputs for Toggle Bit I on DQ6. Figure 7 shows the toggle bit algorithm. Figure 19 in "Read Operation Timings" shows the toggle bit timing diagrams. Figure 20 shows the differences between DQ2 and DQ6 in graphical form. See also the DQ2: Toggle Bit II.

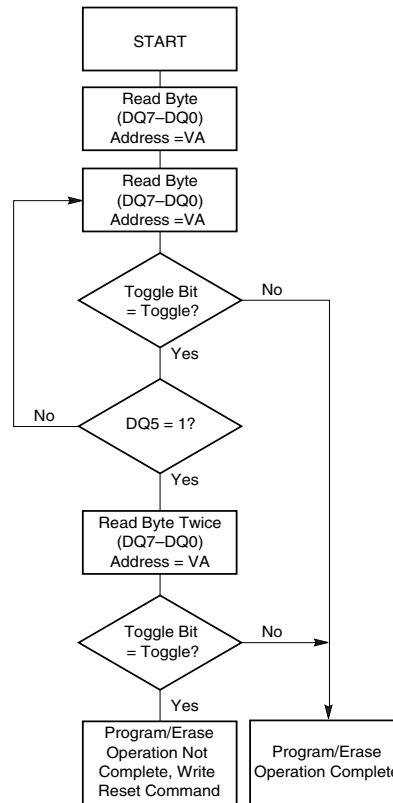

Note: The system should recheck the toggle bit even if DQ5 = "1" because the toggle bit may stop toggling as DQ5 changes to "1." See the DQ6: Toggle Bit I and DQ2: Toggle Bit II for more information.

Figure 7. Toggle Bit Algorithm

DQ2: Toggle Bit II

The "Toggle Bit II" on DQ2, when used with DQ6, indicates whether a particular sector is actively erasing (that is, the Embedded Erase algorithm is in progress), or whether that sector is erase-suspended. Toggle Bit II is valid after the rising edge of the final WE# pulse in the command sequence.

DQ2 toggles when the system reads at addresses within those sectors that have been selected for erasure. (The system may use either OE# or CE# to control the read cycles.) But DQ2 cannot distinguish whether the sector is actively erasing or is erase-suspended. DQ6, by comparison, indicates whether the device is actively erasing, or is in Erase Suspend, but cannot distinguish which sectors are selected for erasure. Thus, both status bits are required for sector and mode information. Refer to Table 19 to compare outputs for DQ2 and DQ6.

Figure 7 shows the toggle bit algorithm in flowchart form, and the DQ2: Toggle Bit II explains the algorithm. See also the DQ6: Toggle Bit I. Figure 19 shows the toggle bit timing diagram. Figure 20 shows the differences between DQ2 and DQ6 in graphical form.

Reading Toggle Bits DQ6/DQ2

Refer to Figure 7 for the following discussion. Whenever the system initially begins reading toggle bit status, it must read DQ7-DQ0 at least twice in a row to determine whether a toggle bit is toggling. Typically, the system would note and

store the value of the toggle bit after the first read. After the second read, the system would compare the new value of the toggle bit with the first. If the toggle bit is not toggling, the device has completed the program or erase operation. The system can read array data on DQ7–DQ0 on the following read cycle.

However, if after the initial two read cycles, the system determines that the toggle bit is still toggling, the system also should note whether the value of DQ5 is high (see the section on DQ5). If it is, the system should then determine again whether the toggle bit is toggling, since the toggle bit may have stopped toggling just as DQ5 went high. If the toggle bit is no longer toggling, the device has successfully completed the program or erase operation. If it is still toggling, the device did not complete the operation successfully, and the system must write the reset command to return to reading array data.

The remaining scenario is that the system initially determines that the toggle bit is toggling and DQ5 has not gone high. The system may continue to monitor the toggle bit and DQ5 through successive read cycles, determining the status as described in the previous paragraph. Alternatively, it may choose to perform other system tasks. In this case, the system must start at the beginning of the algorithm when it returns to determine the status of the operation (top of [Figure 7](#)).

DQ5: Exceeded Timing Limits

DQ5 indicates whether the program or erase time has exceeded a specified internal pulse count limit. Under these conditions DQ5 produces a “1,” indicating that the program or erase cycle was not successfully completed.

The device may output a “1” on DQ5 if the system tries to program a “1” to a location that was previously programmed to “0.” **Only an erase operation can change a “0” back to a “1.”** Under this condition, the device halts the operation, and when the timing limit has been exceeded, DQ5 produces a “1.”

Under both these conditions, the system must write the reset command to return to the read mode (or to the erase-suspend-read mode if a bank was previously in the erase-suspend-program mode).

DQ3: Sector Erase Timer

After writing a sector erase command sequence, the system may read DQ3 to determine whether or not erasure has begun. (The sector erase timer does not apply to the chip erase command.) If additional sectors are selected for erasure, the entire time-out also applies after each additional sector erase command. When the time-out period is complete, DQ3 switches from a “0” to a “1.” See also the Sector Erase Command Sequence.

After the sector erase command is written, the system should read the status of DQ7 (Data# Polling) or DQ6 (Toggle Bit I) to ensure that the device has accepted the command sequence, and then read DQ3. If DQ3 is “1,” the Embedded Erase algorithm has begun; all further commands (except Erase Suspend) are ignored until the erase operation is complete. If DQ3 is “0,” the device will accept additional sector erase commands. To ensure the command has been accepted, the system software should check the status of DQ3 prior to and following each subsequent sector erase command. If DQ3 is high on the second status check, the last command might not have been accepted.

Table 19 shows the status of DQ3 relative to the other status bits.

Table I9.

Status		DQ7 (Note 2)	DQ6	DQ5 (Note 1)	DQ3	DQ2 (Note 2)	RY/BY#	
Standard Mode	Embedded Program Algorithm	DQ7#	Toggle	0	N/A	No toggle	0	
	Embedded Erase Algorithm	0	Toggle	0	1	Toggle	0	
Erase Suspend Mode	Erase-Suspend-Read	Erase Suspended Sector	1	No toggle	0	N/A	Toggle	1
		Non-Erase Suspended Sector	Data	Data	Data	Data	Data	1
	Erase-Suspend-Program		DQ7#	Toggle	0	N/A	N/A	0

Notes:

1. DQ5 switches to '1' when an Embedded Program or Embedded Erase operation has exceeded the maximum timing limits. Refer to the section on DQ5 for more information.
2. DQ7 and DQ2 require a valid address when reading status information. Refer to the appropriate subsection for further details.
3. When reading write operation status bits, the system must always provide the bank address where the Embedded Algorithm is in progress. The device outputs array data if the system addresses a non-busy bank.

Absolute Maximum Ratings

Storage Temperature Plastic Packages -65°C to +150°C
 Ambient Temperature with Power Applied -65°C to +125°C

Voltage with Respect to Ground

V_{CC} (Note 1) -0.5 V to +4.0 V
 RESET# (Note 2) -0.5 V to +13.0 V
 WP#/ACC (Note 2) -0.5 V to +10.5 V
 All other pins (Note 1) -0.5 V to $V_{CC} + 0.5$ V
 Output Short Circuit Current (Note 3) 200 mA

Notes:

1. Minimum DC voltage on input or I/O pins is -0.5 V. During voltage transitions, input or I/O pins may overshoot V_{SS} to -2.0 V for periods of up to 20 ns. Maximum DC voltage on input or I/O pins is $V_{CC} + 0.5$ V. During voltage transitions, input or I/O pins may overshoot to $V_{CC} + 2.0$ V for periods up to 20 ns. See Figure 8.
2. Minimum DC input voltage on pins A9, OE#, RESET#, and WP#/ACC is -0.5 V. During voltage transitions, A9, OE#, WP#/ACC, and RESET# may overshoot V_{SS} to -2.0 V for periods of up to 20 ns. See Figure 8. Maximum DC input voltage on pin A9, OE#, and RESET# is +12.5 V which may overshoot to +14.0 V for periods up to 20 ns. Maximum DC input voltage on WP#/ACC is +9.5 V which may overshoot to +12.0 V for periods up to 20 ns.
3. No more than one output may be shorted to ground at a time. Duration of the short circuit should not be greater than one second.
4. Stresses above those listed under "Absolute Maximum Ratings" may cause permanent damage to the device. This is a stress rating only; functional operation of the device at these or any other conditions above those indicated in the operational sections of this data sheet is not implied. Exposure of the device to absolute maximum rating conditions for extended periods may affect device reliability.

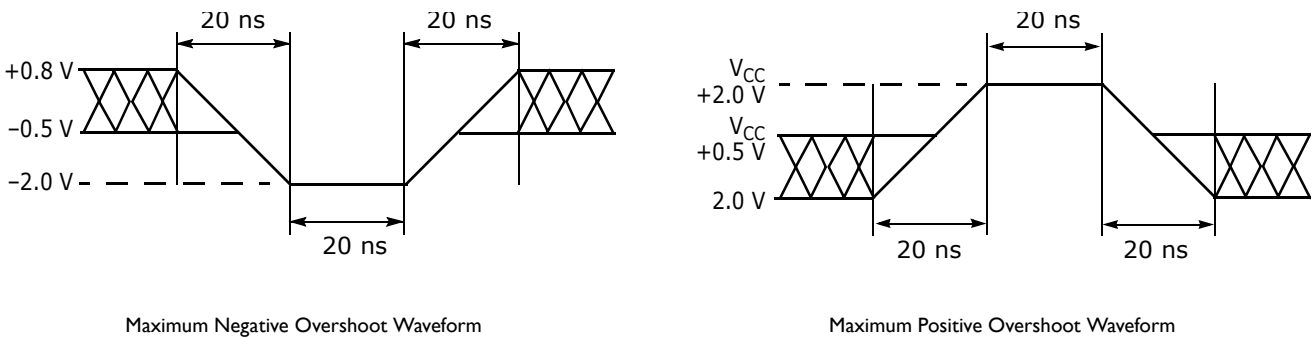

Figure 8. Maximum Overshoot Waveforms

Operating Ranges

Operating ranges define those limits between which the functionality of the device is guaranteed.

Industrial (I) Devices

Ambient Temperature (T_A) -40°C to $+85^{\circ}\text{C}$

Wireless Devices

Ambient Temperature (T_A) -25°C to $+85^{\circ}\text{C}$

Supply Voltages

V_{CC} 2.7–3.1 V

V_{IO} (see Note) . . 1.65–1.95 V (for PL127J) or 2.7–3.1 V (for all PLxxxJ devices)

Notes:

For all AC and DC specifications, $V_{IO} = V_{CC}$; contact your local sales office for other V_{IO} options.

DC Characteristics

Table 20. CMOS Compatible

Parameter Symbol	Parameter Description	Test Conditions	Min	Typ	Max	Unit
I_{LI}	Input Load Current	$V_{IN} = V_{SS}$ to V_{CC} , $V_{CC} = V_{CC\ max}$			± 1.0	μA
I_{LIT}	A9, OE#, RESET# Input Load Current	$V_{CC} = V_{CC\ max}$; $V_{ID} = 12.5\ V$			35	μA
I_{LR}	Reset Leakage Current	$V_{CC} = V_{CC\ max}$; $V_{ID} = 12.5\ V$			35	μA
I_{LO}	Output Leakage Current	$V_{OUT} = V_{SS}$ to V_{CC} , OE# = V_{IH} $V_{CC} = V_{CC\ max}$			± 1.0	μA
I_{CC1}	V_{CC} Active Read Current (Notes 1, 2)	OE# = V_{IH} , $V_{CC} = V_{CC\ max}$ (Note 1)	5 MHz	15	25	mA
			10 MHz	45	55	
I_{CC2}	V_{CC} Active Write Current (Notes 2, 3)	OE# = V_{IH} , WE# = V_{IL}		15	25	mA
I_{CC3}	V_{CC} Standby Current (Note 2)	CE#, RESET#, WP#/ACC = $V_{IO} \pm 0.3\ V$		0.2	5	μA
I_{CC4}	V_{CC} Reset Current (Note 2)	RESET# = $V_{SS} \pm 0.3\ V$		0.2	5	μA
I_{CC5}	Automatic Sleep Mode (Notes 2, 4)	$V_{IH} = V_{IO} \pm 0.3\ V$; $V_{IL} = V_{SS} \pm 0.3\ V$		0.2	5	μA
I_{CC6}	V_{CC} Active Read-While-Program Current (Notes 1, 2)	OE# = V_{IH} ,	5 MHz	21	45	mA
			10 MHz	46	70	
I_{CC7}	V_{CC} Active Read-While-Erase Current (Notes 1, 2)	OE# = V_{IH} ,	5 MHz	21	45	mA
			10 MHz	46	70	
I_{CC8}	V_{CC} Active Program-While-Erase-Suspended Current (Notes 2, 5)	OE# = V_{IH}		17	25	mA
I_{CC9}	V_{CC} Active Page Read Current (Note 2)	OE# = V_{IH} , 8 word Page Read		10	15	mA
V_{IL}	Input Low Voltage	$V_{IO} = 1.65\text{--}1.95\ V$ (PL127J)	-0.4		0.4	V
		$V_{IO} = 2.7\text{--}3.6\ V$	-0.5		0.8	V
V_{IH}	Input High Voltage	$V_{IO} = 1.65\text{--}1.95\ V$ (PL127J)	$V_{IO}-0.4$		$V_{IO}+0.4$	V
		$V_{IO} = 2.7\text{--}3.6\ V$	2.0		$V_{CC}+0.3$	V
V_{HH}	Voltage for ACC Program Acceleration	$V_{CC} = 3.0\ V \pm 10\%$	8.5		9.5	V
V_{ID}	Voltage for Autoselect and Temporary Sector Unprotect	$V_{CC} = 3.0\ V \pm 10\%$	11.5		12.5	V
V_{OL}	Output Low Voltage	$I_{OL} = 100\ \mu A$, $V_{CC} = V_{CC\ min}$, $V_{IO} = 1.65\text{--}1.95\ V$ (PL127J)			0.1	V
		$I_{OL} = 2.0\ mA$, $V_{CC} = V_{CC\ min}$, $V_{IO} = 2.7\text{--}3.6\ V$			0.4	V
V_{OH}	Output High Voltage	$I_{OH} = -100\ \mu A$, $V_{CC} = V_{CC\ min}$, $V_{IO} = 1.65\text{--}1.95\ V$ (PL127J)	$V_{IO}-0.1$			V
		$I_{OH} = -2.0\ mA$, $V_{CC} = V_{CC\ min}$, $V_{IO} = 2.7\text{--}3.6\ V$	2.4			V
V_{LKO}	Low V_{CC} Lock-Out Voltage (Note 5)		2.3		2.5	V

Notes:

1. The I_{CC} current listed is typically less than 5 mA/MHz, with OE# at V_{IH} .
2. Maximum I_{CC} specifications are tested with $V_{CC} = V_{CC\ max}$.
3. I_{CC} active while Embedded Erase or Embedded Program is in progress.
4. Automatic sleep mode enables the low power mode when addresses remain stable for $t_{ACC} + 30\ ns$. Typical sleep mode current is 1 mA.
5. Not 100% tested.
6. Valid CE1#/CE2# conditions: (CE1# = V_{IL} , CE2# = V_{IH}) or (CE1# = V_{IH} , CE2# = V_{IL}) or (CE1# = V_{IH} , CE2# = V_{IH})

AC Characteristic

Test Conditions

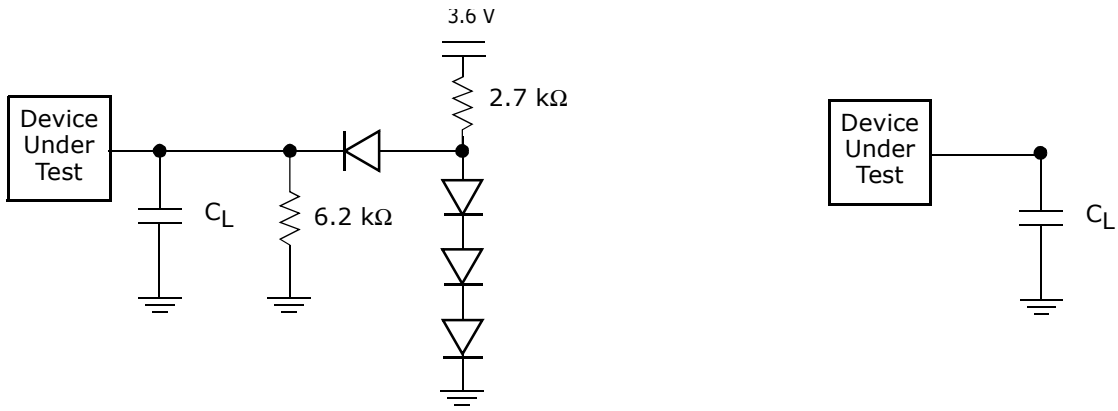

$V_{IO} = 3.0\text{ V}$

Note: Diodes are IN3064 or equivalent

$V_{IO} = 1.8\text{ V (PL127J)}$

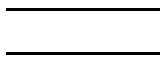



Figure 9. Test Setups

Table 2I. Test Specifications

Test Condition		All Speeds	Unit
Output Load		1 TTL gate	
Output Load Capacitance, C_L (including jig capacitance)		30	pF
Input Rise and Fall Times	$V_{IO} = 1.8\text{ V}$ (PL127J)	5	ns
	$V_{IO} = 3.0\text{ V}$		
Input Pulse Levels	$V_{IO} = 1.8\text{ V}$ (PL127J)	0.0 - 1.8	V
	$V_{IO} = 3.0\text{ V}$	0.0-3.0	
Input timing measurement reference levels		$V_{IO}/2$	V
Output timing measurement reference levels		$V_{IO}/2$	V

Switching Waveforms

Table 22. Key to Switching Waveforms

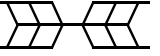
Waveform	Inputs	Outputs
	Steady	
	Changing from H to L	
	Changing from L to H	
	Don't Care, Any Change Permitted	Changing, State Unknown
	Does Not Apply	Center Line is High Impedance State (High Z)

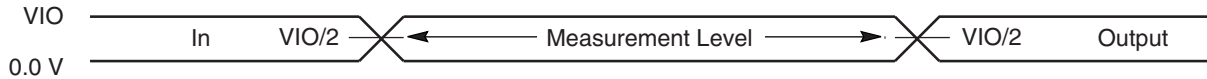

Figure 10. Input Waveforms and Measurement Levels

VCC RampRate

All DC characteristics are specified for a V_{CC} ramp rate $> 1V/100 \mu s$ and $V_{CC} \geq V_{CCQ} - 100 mV$. If the V_{CC} ramp rate is $< 1V/100 \mu s$, a hardware reset required.

Read Operations

Table 23. Read-Only Operations

Parameter		Description	Test Setup		Speed Options				Unit
JEDEC	Std.				55	60	65	70	
t_{AVAV}	t_{RC}	Read Cycle Time (Note 1)		Min	55	60	65	70	ns
t_{AVQV}	t_{ACC}	Address to Output Delay	CE#, OE# = V_{IL}	Max	55	60	65	70	ns
t_{ELQV}	t_{CE}	Chip Enable to Output Delay	OE# = V_{IL}	Max	55	60	65	70	ns
	t_{PACC}	Page Access Time		Max	20	25	30		ns
t_{GLQV}	t_{OE}	Output Enable to Output Delay		Max	20	25	30		ns
t_{EHQZ}	t_{DF}	Chip Enable to Output High Z (Note 3)		Max	16				ns
t_{GHQZ}	t_{DF}	Output Enable to Output High Z (Notes 1, 3)		Max	16				ns
t_{AXQX}	t_{OH}	Output Hold Time From Addresses, CE# or OE#, Whichever Occurs First (Note 3)		Min	5				ns
	t_{OEh}	Output Enable Hold Time (Note 1)	Read	Min	0				ns
			Toggle and Data# Polling	Min	10				ns

Notes:

1. Not 100% tested.
2. See [Figure 9](#) and [Table 21](#) for test specifications.
3. Measurements performed by placing a 50 ohm termination on the data pin with a bias of $V_{CC}/2$. The time from OE# high to the data bus driven to $V_{CC}/2$ is taken as t_{DF} .
4. For 70pF Output Load Capacitance, 2 ns will be added to the above $t_{ACC}, t_{CE}, t_{PACC}, t_{OE}$ values for all speed grades.

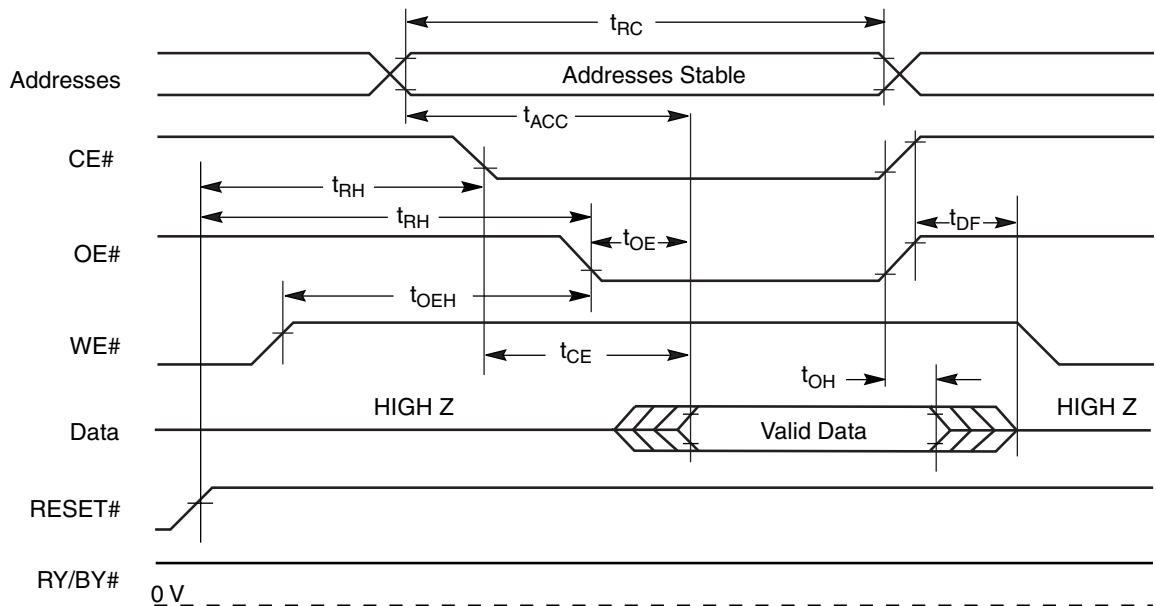

Figure II. Read Operation Timings

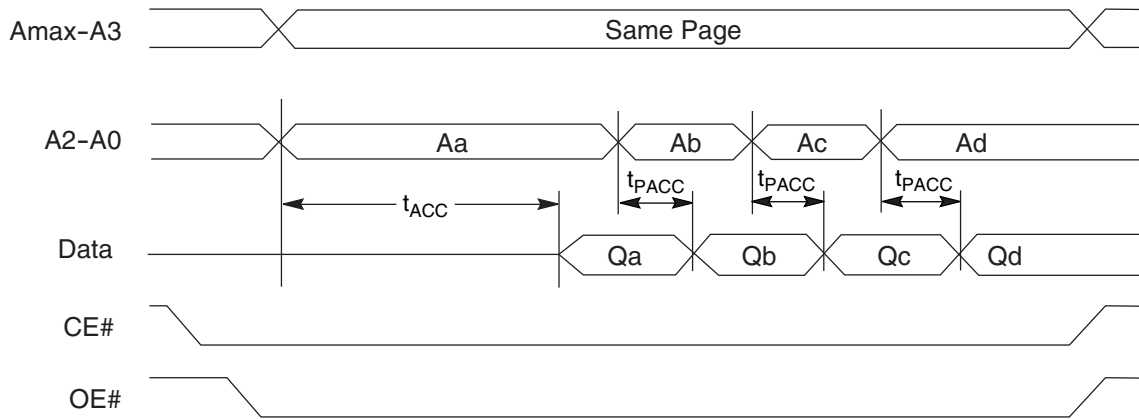

Figure I2. Page Read Operation Timings

Reset

Table 24. Hardware Reset (RESET#)

Parameter		Description		All Speed Options	Unit
JEDEC	Std				
	t_{Ready}	RESET# Pin Low (During Embedded Algorithms) to Read Mode (See Note)	Max	35	μs
	t_{Ready}	RESET# Pin Low (NOT During Embedded Algorithms) to Read Mode (See Note)	Max	500	ns
	t_{RP}	RESET# Pulse Width	Min	500	ns
	t_{RH}	Reset High Time Before Read (See Note)	Min	50	ns
	t_{RPD}	RESET# Low to Standby Mode	Min	20	μs
	t_{RB}	RY/BY# Recovery Time	Min	0	ns

Note: Not 100% tested.

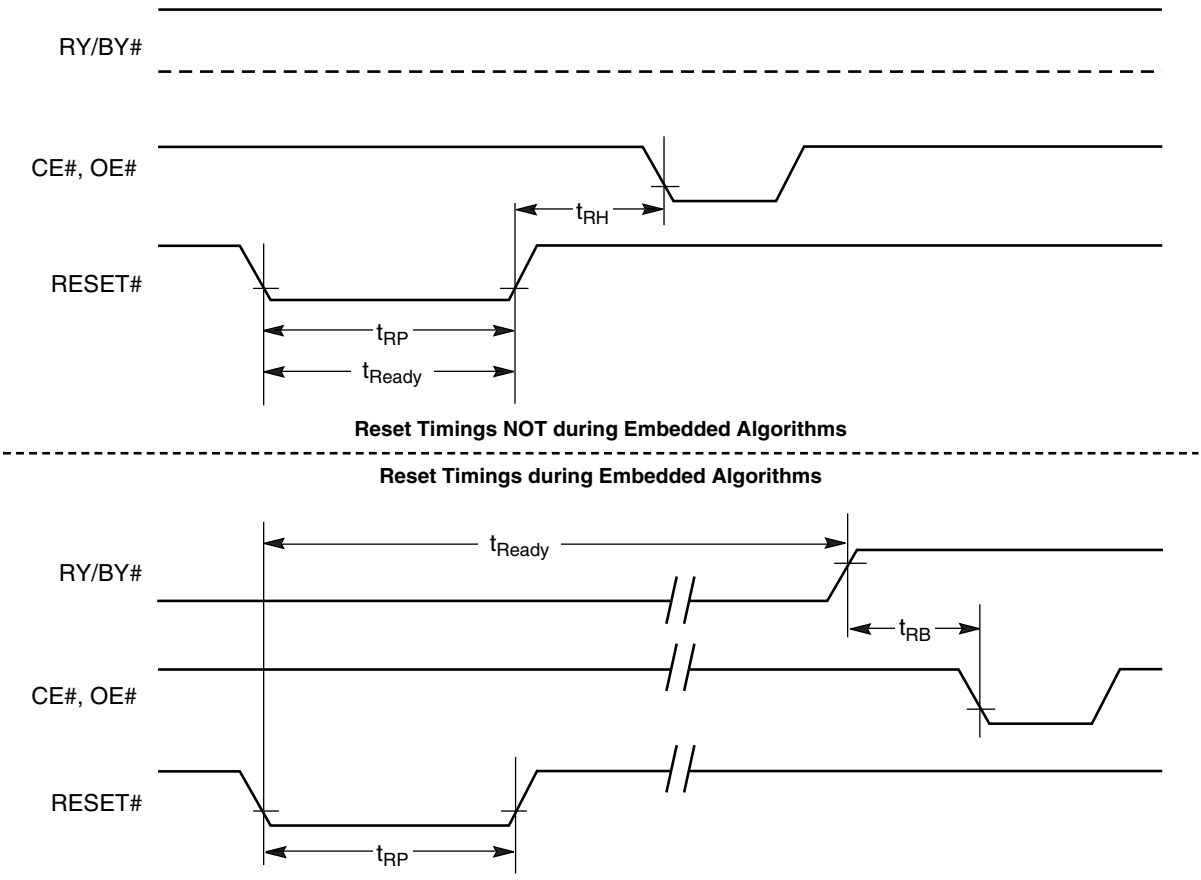

Figure I3. Reset Timings

Erase/Program Operations

Table 25. Erase and Program Operations

Parameter		Description		Speed Options				Unit
JEDEC	Std			55	60	65	70	
t _{AVAV}	t _{WC}	Write Cycle Time (Note 1)	Min	55	60	65	70	ns
t _{AVWL}	t _{AS}	Address Setup Time	Min	0				ns
	t _{ASO}	Address Setup Time to OE# low during toggle bit polling	Min	15				ns
t _{WLAX}	t _{AH}	Address Hold Time	Min	30	35			ns
	t _{AHT}	Address Hold Time From CE# or OE# high during toggle bit polling	Min	0				ns
t _{DVWH}	t _{DS}	Data Setup Time	Min	25	30			ns
t _{WHDX}	t _{DH}	Data Hold Time	Min	0				ns
	t _{OEPH}	Output Enable High during toggle bit polling	Min	10				ns
t _{GHWL}	t _{GHWL}	Read Recovery Time Before Write (OE# High to WE# Low)	Min	0				ns
t _{ELWL}	t _{CS}	CE# Setup Time	Min	0				ns
t _{WHEH}	t _{CH}	CE# Hold Time	Min	0				ns
t _{WLWH}	t _{WP}	Write Pulse Width	Min	35	40			ns
t _{WHDL}	t _{WPH}	Write Pulse Width High	Min	20	25			ns
	t _{SR/W}	Latency Between Read and Write Operations	Min	0				ns
t _{WHWH1}	t _{WHWH1}	Programming Operation (Note 2)	Typ	6				μs
t _{WHWH1}	t _{WHWH1}	Accelerated Programming Operation (Note 2)	Typ	4				μs
t _{WHWH2}	t _{WHWH2}	Sector Erase Operation (Note 2)	Typ	0.5				sec
	t _{VCS}	V _{CC} Setup Time (Note 1)	Min	50				μs
	t _{RB}	Write Recovery Time from RY/BY#	Min	0				ns
	t _{BUSY}	Program/Erase Valid to RY/BY# Delay	Max	90				ns

Notes:

1. Not 100% tested.
2. See the "Erase And Programming Performance" section for more information.

Timing Diagrams

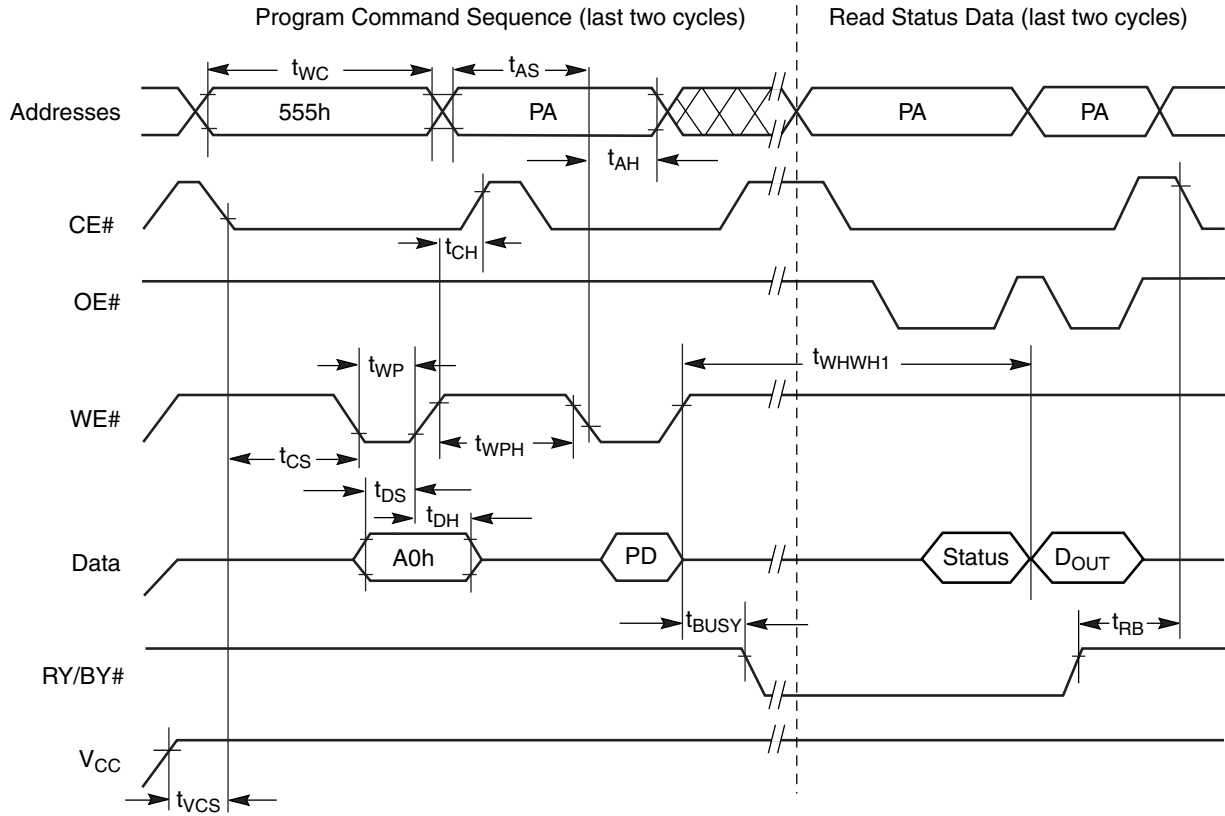

Notes:

1. PA = program address, PD = program data, D_{OUT} is the true data at the program address

Figure 14. Program Operation Timings

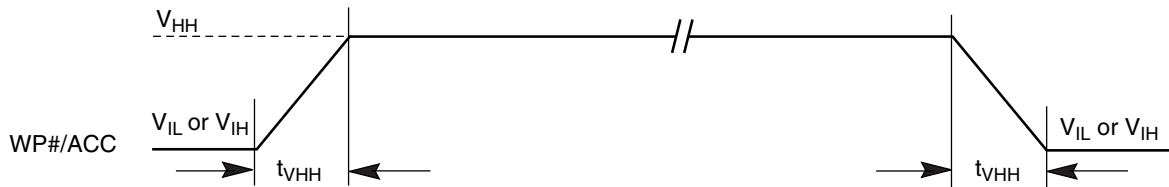
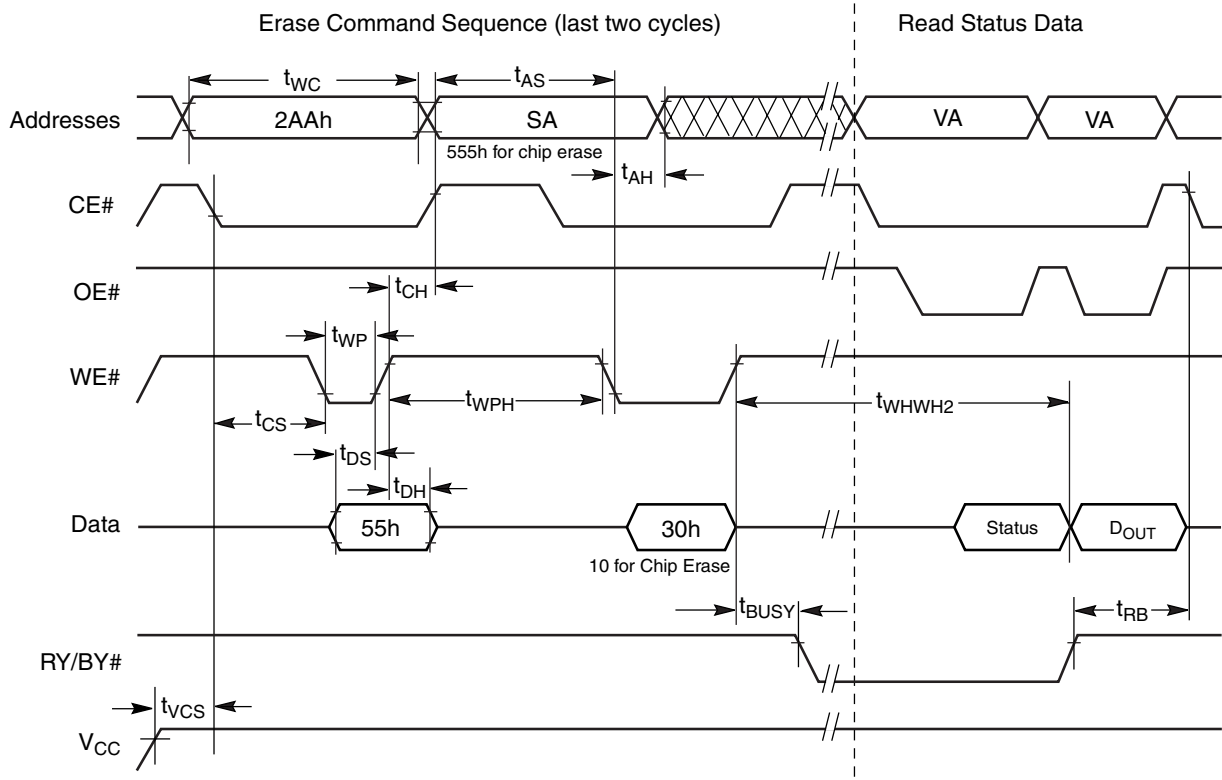

Figure 15. Accelerated Program Timing Diagram



Notes:

1. SA = sector address (for Sector Erase), VA = Valid Address for reading status data (

Figure 16. Chip/Sector Erase Operation Timings

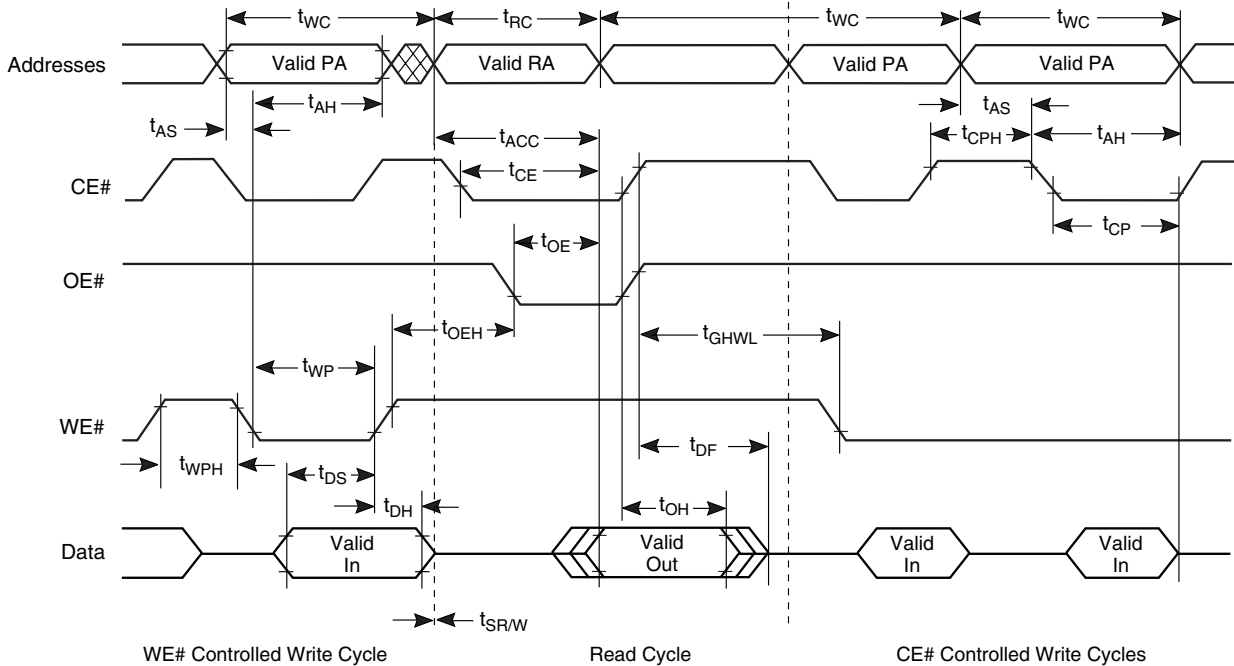
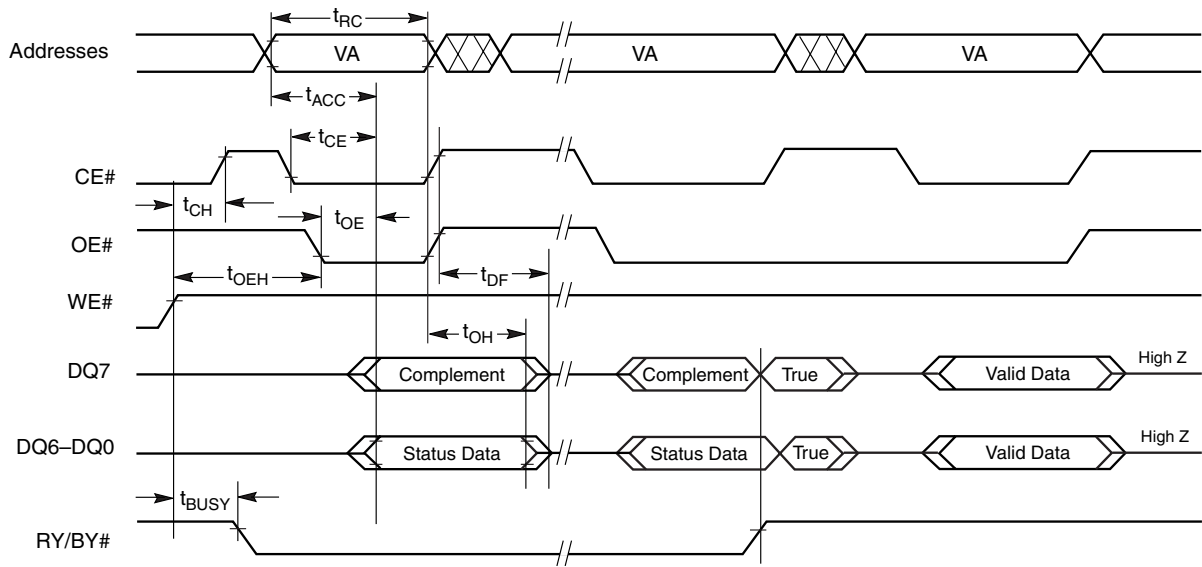
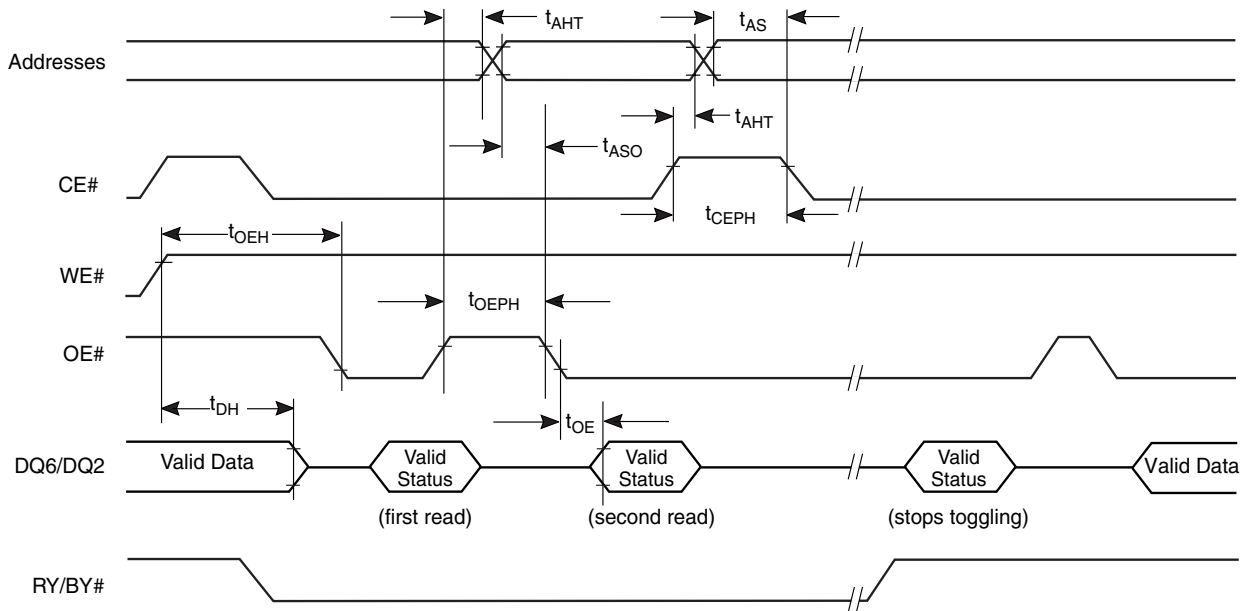

Figure 17. Back-to-back Read/Write Cycle Timings



Note: VA = Valid address. Illustration shows first status cycle after command sequence, last status read cycle, and array data read cycle

Figure I8. Data# Polling Timings (During Embedded Algorithms)



Notes:

1. VA = Valid address; not required for DQ6. Illustration shows first two status cycle after command sequence, last status read cycle, and array data read cycle

Figure I9. Toggle Bit Timings (During Embedded Algorithms)

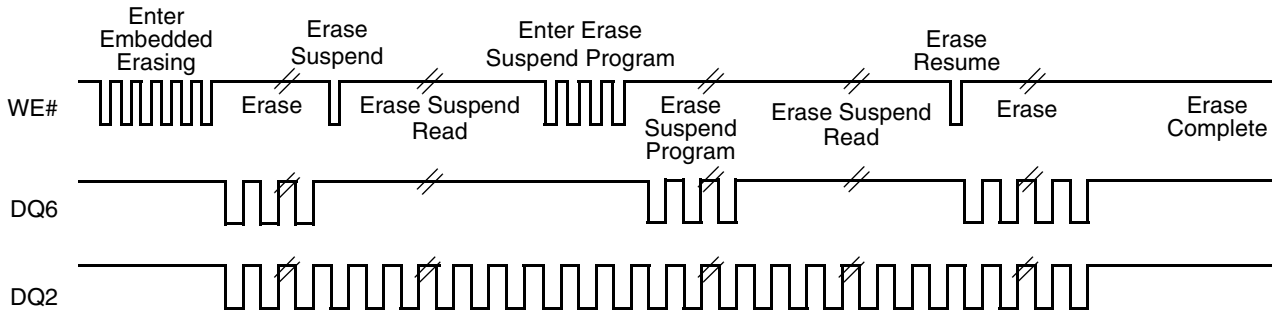

Note: DQ2 toggles only when read at an address within an erase-suspended sector. The system may use OE# or CE# to toggle DQ2 and DQ6.

Figure 20. DQ2 vs. DQ6

Protect/Unprotect

Table 26. Temporary Sector Unprotect

Parameter		Description		All Speed Options	Unit
JEDEC	Std				
	t_{VIDR}	V_{ID} Rise and Fall Time (See Note)	Min	500	ns
	t_{VHH}	V_{HH} Rise and Fall Time (See Note)	Min	250	ns
	t_{RSP}	RESET# Setup Time for Temporary Sector Unprotect	Min	4	μ s
	t_{RRB}	RESET# Hold Time from RY/BY# High for Temporary Sector Unprotect	Min	4	μ s

Note: Not 100% tested.

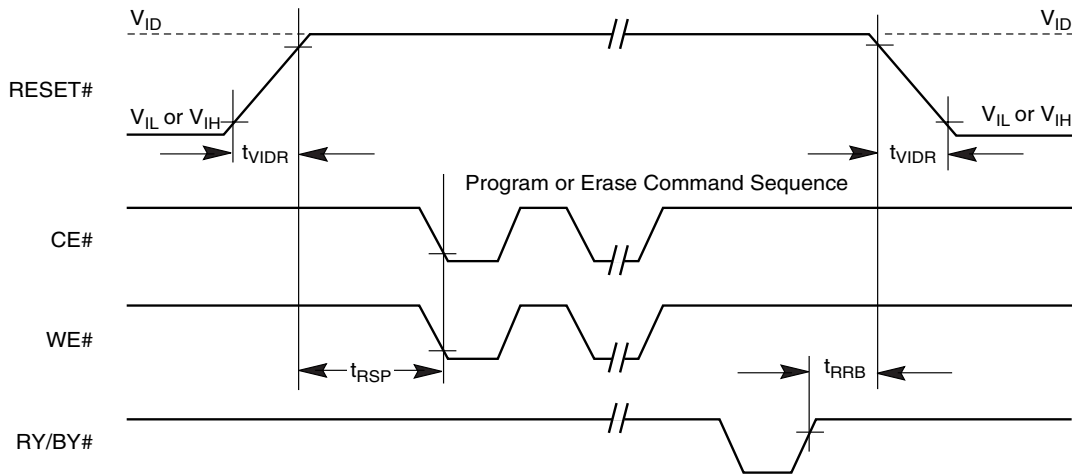
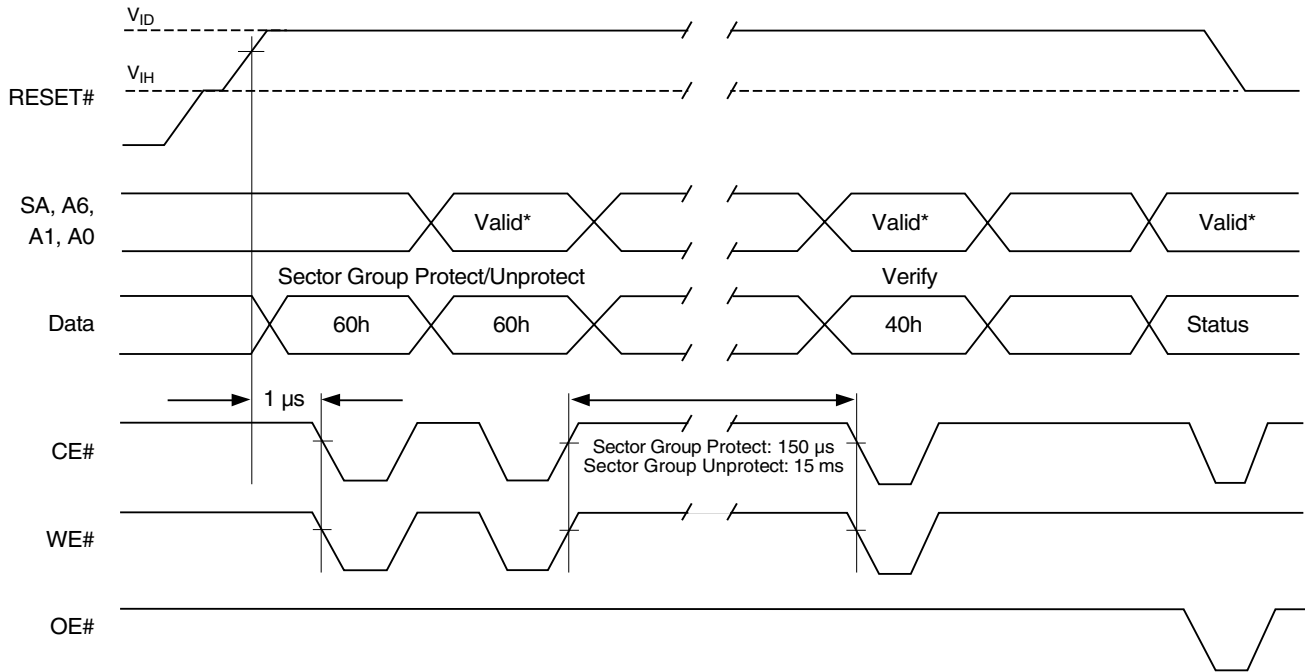

Figure 21. Temporary Sector Unprotect Timing Diagram



Notes:

1. For sector protect, A6 = 0, A1 = 1, A0 = 0. For sector unprotect, A6 = 1, A1 = 1, A0 = 0.

Figure 22. Sector/Block Protect and Unprotect Timing Diagram

Controlled Erase Operations

Table 27. Alternate CE# Controlled Erase and Program Operations

Parameter		Description		Speed Options				Unit
JEDEC	Std			55	60	65	70	
t _{AVAV}	t _{WC}	Write Cycle Time (Note 1)	Min	55	60	65	70	ns
t _{AVWL}	t _{AS}	Address Setup Time	Min	0				ns
t _{ELAX}	t _{AH}	Address Hold Time	Min	30	35			ns
t _{DVEH}	t _{DS}	Data Setup Time	Min	25	30			ns
t _{EHDX}	t _{DH}	Data Hold Time	Min	0				ns
t _{GHEL}	t _{GHEL}	Read Recovery Time Before Write (OE# High to WE# Low)	Min	0				ns
t _{WLEL}	t _{WS}	WE# Setup Time	Min	0				ns
t _{EHWH}	t _{WH}	WE# Hold Time	Min	0				ns
t _{ELEH}	t _{CP}	CE# Pulse Width	Min	35	40			ns
t _{EHEL}	t _{CPH}	CE# Pulse Width High	Min	20	25			ns
t _{WHWH1}	t _{WHWH1}	Programming Operation (Note 2)	Typ	6				µs
t _{WHWH1}	t _{WHWH1}	Accelerated Programming Operation (Note 2)	Typ	4				µs
t _{WHWH2}	t _{WHWH2}	Sector Erase Operation (Note 2)	Typ	0.5				sec

Notes:

1. Not 100% tested.
2. See the "Erase And Programming Performance" section for more information.

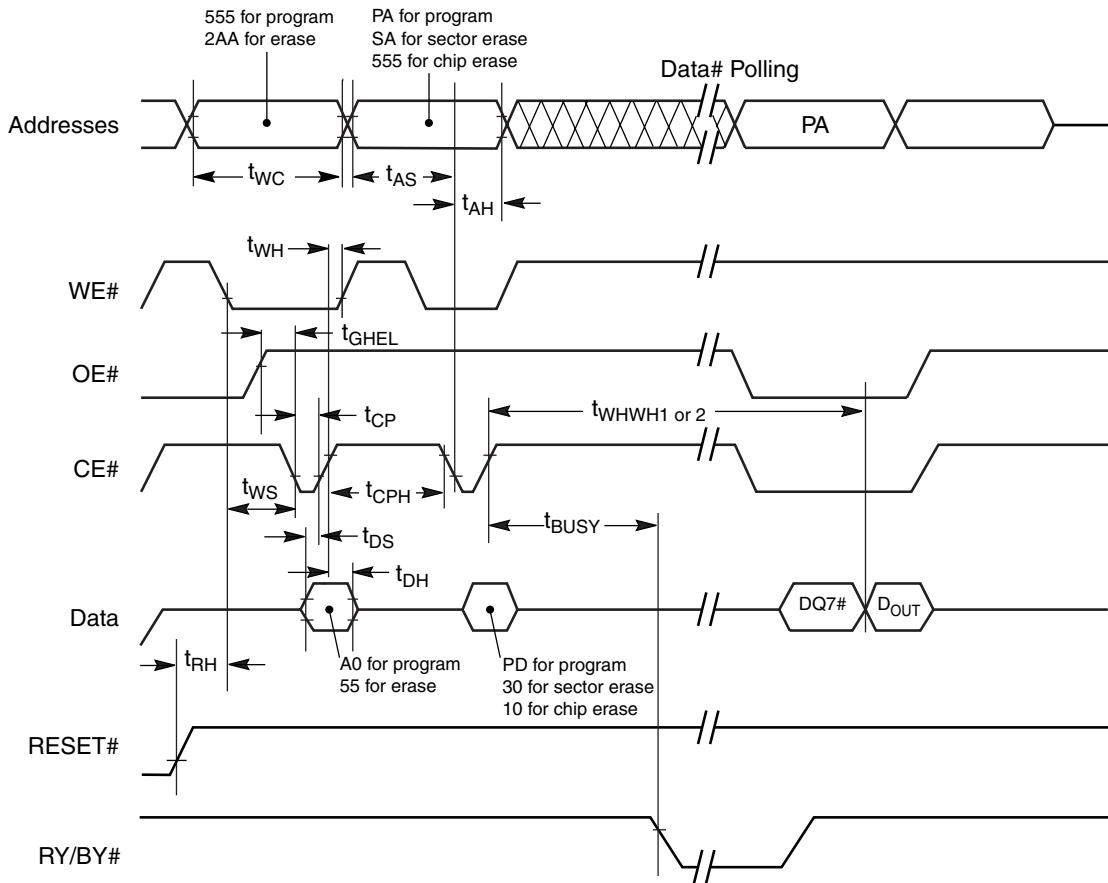

Notes:

1. Figure indicates last two bus cycles of a program or erase operation.
2. PA = program address, SA = sector address, PD = program data.
3. DQ7# is the complement of the data written to the device. D_{OUT} is the data written to the device

Table 28. Alternate CE# Controlled Write (Erase/Program) Operation Timings

Table 29. Erase And Programming Performance

Parameter		Typ (Note 1)	Max (Note 2)	Unit	Comments
Sector Erase Time		0.5	2	sec	Excludes 00h programming prior to erasure (Note 4)
Chip Erase Time	PL127J	135	216	sec	
	PL064J	71	113.6	sec	
	PL032J	39	62.4	sec	
Word Program Time		6	100	μs	Excludes system level overhead (Note 5)
Accelerated Word Program Time		4	60	μs	
Chip Program Time (Note 3)	PL127J	50.4	200	sec	
	PL064J	25.2	50.4	sec	
	PL032J	12.6	25.2	sec	

Notes:

1. Typical program and erase times assume the following conditions: $25\times C$, $3.0\text{ V }V_{CC}$, 100,000 cycles. Additionally, programming typicals assume checkerboard pattern. All values are subject to change.
2. Under worst case conditions of $90\times C$, $V_{CC} = 2.7\text{ V}$, 100,000 cycles. All values are subject to change.
3. The typical chip programming time is considerably less than the maximum chip programming time listed, since most bytes program faster than the maximum program times listed.
4. In the pre-programming step of the Embedded Erase algorithm, all bytes are programmed to 00h before erasure.
5. System-level overhead is the time required to execute the two- or four-bus-cycle sequence for the program command. See Table 17 for further information on command definitions.
6. The device has a minimum erase and program cycle endurance of 100,000 cycles.

BGA Pin Capacitance

Parameter Symbol	Parameter Description	Test Setup	Typ	Max	Unit
C_{IN}	Input Capacitance	$V_{IN} = 0$	6.3	7	pF
C_{OUT}	Output Capacitance	$V_{OUT} = 0$	7.0	8	pF
C_{IN2}	Control Pin Capacitance	$V_{IN} = 0$	5.5	8	pF
C_{IN3}	WP#/ACC Pin Capacitance	$V_{IN} = 0$	11	12	pF

Notes:

1. Sampled, not 100% tested.
2. Test conditions $T_A = 25^\circ\text{C}$, $f = 1.0\text{ MHz}$.

Type 2 pSRAM

16Mb (1Mb Word x 16-bit)

32Mb (2Mb Word x 16-bit)

64Mb (4Mb Word x 16-bit)

Features

- Process Technology: CMOS
- Organization: x16 bit
- Power Supply Voltage: 2.7~3.1V
- Three State Outputs
- Compatible with Low Power SRAM

Product Information

Density	V _{CC} Range	Standby (ISBI, Max.)	Operating (ICC2, Max.)	Mode
16Mb	2.7-3.1V	80 μ A	30 mA	Dual CS
16Mb	2.7-3.1V	80 μ A	35 mA	Dual CS and Page Mode
32Mb	2.7-3.1V	100 μ A	35 mA	Dual CS
32Mb	2.7-3.1V	100 μ A	40 mA	Dual CS and Page Mode
64Mb	2.7-3.1V	TBD	TBD	Dual CS
64Mb	2.7-3.1V	TBD	TBD	Dual CS and Page Mode

Pin Description

Pin Name	Description	I/O
CS1#, CS2	Chip Select	I
OE#	Output Enable	I
WE#	Write Enable	I
LB#, UB#	Lower/Upper Byte Enable	I
A0-A19 (16M) A0-A20 (32M) A0-A21 (64M)	Address Inputs	I
I/O0-I/O15	Data Inputs/Outputs	I/O
V _{CC} /V _{CCQ}	Power Supply	—
V _{SS} /V _{SSQ}	Ground	—
NC	Not Connection	—
DNU	Do Not Use	—

Power Up Sequence

1. Apply power.
2. Maintain stable power (V_{CC} min.=2.7V) for a minimum 200 μ s with CS1#=high or CS2=low.

Timing Diagrams

Power Up

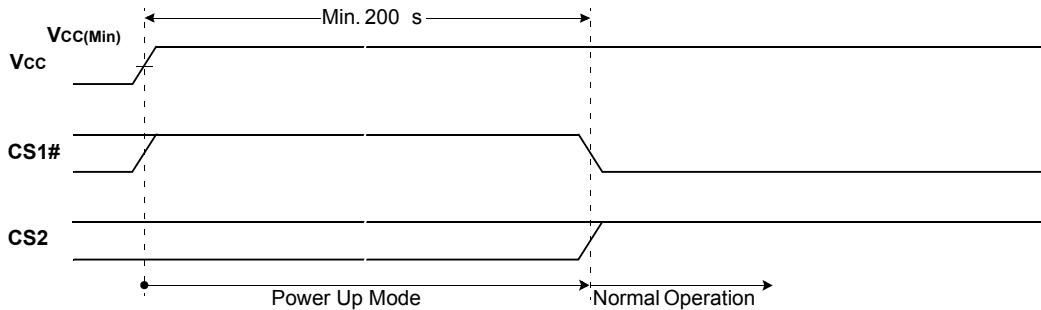

Figure 23. Power Up I (CS1# Controlled)

Notes:

1. After V_{CC} reaches $V_{CC}(\text{Min.})$, wait 200 μ s with CS1# high. Then the device gets into the normal operation.

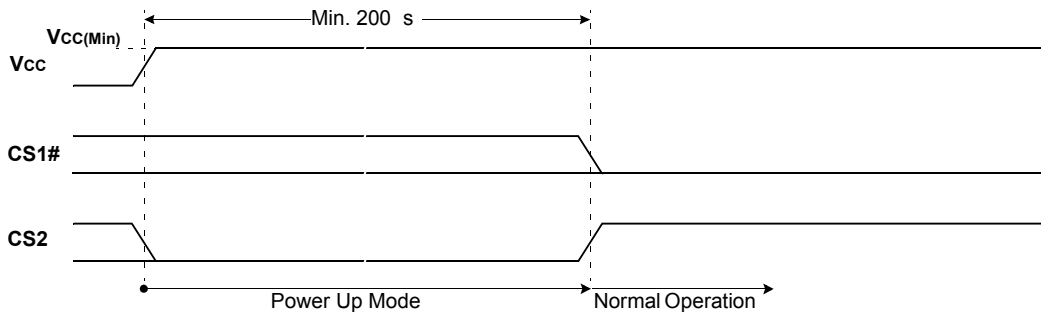

Figure 24. Power Up 2 (CS2 Controlled)

Notes:

1. After V_{CC} reaches $V_{CC}(\text{Min.})$, wait 200 μ s with CS2 low. Then the device gets into the normal operation.

Functional Description

Mode	CS1#	CS2	OE#	WE#	LB#	UB#	I/O ₁₋₈	I/O ₉₋₁₆	Power
Deselected	H	X	X	X	X	X	High-Z	High-Z	Standby
Deselected	X	L	X	X	X	X	High-Z	High-Z	Standby
Deselected	X	X	X	X	H	H	High-Z	High-Z	Standby
Output Disabled	L	H	H	H	L	X	High-Z	High-Z	Active
Outputs Disabled	L	H	H	H	X	L	High-Z	High-Z	Active
Lower Byte Read	L	H	L	H	L	H	D _{OUT}	High-Z	Active
Upper Byte Read	L	H	L	H	H	L	High-Z	D _{OUT}	Active
Word Read	L	H	L	H	L	L	D _{OUT}	D _{OUT}	Active
Lower Byte Write	L	H	X	L	L	H	D _{IN}	High-Z	Active
Upper Byte Write	L	H	X	L	H	L	High-Z	D _{IN}	Active
Word Write	L	H	X	L	L	L	D _{IN}	D _{IN}	Active

Legend: X = Don't care (must be low or high state).

Absolute Maximum Ratings

Item	Symbol	Ratings	Unit
Voltage on any pin relative to V _{SS}	V _{IN} , V _{OUT}	-0.2 to V _{CC} +0.3V	V
Voltage on V _{CC} supply relative to V _{SS}	V _{CC}	-0.2 to 3.6V	V
Power Dissipation	P _D	1.0	W
Operating Temperature	T _A	-40 to 85	°C

Notes:

- Stresses greater than those listed under "Absolute Maximum Ratings" section may cause permanent damage to the device. Functional operation should be restricted to be used under recommended operating condition. Exposure to absolute maximum rating conditions longer than 1 second may affect reliability.

DC Recommended Operating Conditions

Symbol	Parameter	Min	Typ	Max	Unit
V _{CC}	Power Supply Voltage	2.7	2.9	3.1	V
V _{SS}	Ground	0	0	0	
V _{IH}	Input High Voltage	2.2	—	V _{CC} + 0.3 (Note 2)	
V _{IL}	Input Low Voltage	-0.2 (Note 3)	—	0.6	

Notes:

- T_A=-40 to 85°C, otherwise specified.
- Overshoot: V_{CC}+1.0V in case of pulse width ≤ 20ns.
- Undershoot: -1.0V in case of pulse width ≤ 20ns.
- Overshoot and undershoot are sampled, not 100% tested.

Capacitance (Ta = 25°C, f = 1 MHz)

Symbol	Parameter	Test Condition	Min	Max	Unit
C _{IN}	Input Capacitance	V _{IN} = 0V	—	8	pF
C _{OIO}	Input/Output Capacitance	V _{OUT} = 0V	—	10	pF

Note: This parameter is sampled periodically and is not 100% tested.

DC and Operating Characteristics

Common

Item	Symbol	Test Conditions	Min	Typ	Max	Unit
Input Leakage Current	I _{LI}	V _{IN} =V _{SS} to V _{CC}	-1	—	1	μA
Output Leakage Current	I _{LO}	CS1#=V _{IH} or CS2=V _{IL} or OE#=V _{IH} or WE#=V _{IL} or LB#=UB#=V _{IH} , V _{IO} =V _{SS} to V _{CC}	-1	—	1	μA
Output Low Voltage	V _{OL}	I _{OL} =2.1mA	—	—	0.4	V
Output High Voltage	V _{OH}	I _{OH} =-1.0mA	2.4	—	—	V

16M pSRAM

Item	Symbol		Test Conditions	Min	Typ	Max	Unit
Average Operating Current	I_{CC1}		Cycle time=1 μ s, 100% duty, $I_{IO}=0$ mA, CS1# ≤ 0.2 V, LB# ≤ 0.2 V and/or UB# ≤ 0.2 V, CS2 $\geq V_{CC}-0.2$ V, $V_{IN}\leq 0.2$ V or $V_{IN}\geq V_{CC}-0.2$ V	—	—	7	mA
	I_{CC2}	Async	Cycle time=Min, $I_{IO}=0$ mA, 100% duty, CS1#= V_{IL} , CS2= V_{IH} LB#= V_{IL} and/or UB#= V_{IL} , $V_{IN}=V_{IH}$ or V_{IL}	—	—	30	mA
		Page	Cycle time= $t_{RC}+3t_{PC}$, $I_{IO}=0$ mA, 100% duty, CS1#= V_{IL} , CS2= V_{IH} LB#= V_{IL} and/or UB#= V_{IL} , $V_{IN}=V_{IH}$ or V_{IL}			35	mA
Standby Current (CMOS)	I_{SB1} (Note 1)		Other inputs=0-VCC 1. CS1# $\geq V_{CC} - 0.2$, CS2 $\geq V_{CC} - 0.2$ V (CS1# controlled) or 2. $0V \leq CS2 \leq 0.2$ V (CS2 controlled)	—	—	80	mA

Notes:

- Standby mode is supposed to be set up after at least one active operation after power up. I_{SB1} is measure after 60ms from the time when standby mode is set up.

32M pSRAM

Item	Symbol		Test Conditions	Min	Typ	Max	Unit
Average Operating Current	I_{CC1}		Cycle time=1 μ s, 100% duty, $I_{IO}=0$ mA, CS1# ≤ 0.2 V, LB# ≤ 0.2 V and/or UB# ≤ 0.2 V, CS2 $\geq V_{CC}-0.2$ V, $V_{IN}\leq 0.2$ V or $V_{IN}\geq V_{CC}-0.2$ V	—	—	7	mA
	I_{CC2}	Async	Cycle time=Min, $I_{IO}=0$ mA, 100% duty, CS1#= V_{IL} , CS2= V_{IH} LB#= V_{IL} and/or UB#= V_{IL} , $V_{IN}=V_{IH}$ or V_{IL}	—	—	35	mA
		Page	Cycle time= $t_{RC}+3t_{PC}$, $I_{IO}=0$ mA, 100% duty, CS1#= V_{IL} , CS2= V_{IH} LB#= V_{IL} and/or UB#= V_{IL} , $V_{IN}=V_{IH}$ or V_{IL}			40	mA
Standby Current (CMOS)	I_{SB1} (Note 1)		Other inputs=0-VCC 1. CS1# $\geq V_{CC} - 0.2$, CS2 $\geq V_{CC} - 0.2$ V (CS1# controlled) or 2. $0V \leq CS2 \leq 0.2$ V (CS2 controlled)	—	—	100	mA

Notes:

- Standby mode is supposed to be set up after at least one active operation after power up. I_{SB1} is measure after 60ms from the time when standby mode is set up.

64M pSRAM

Item	Symbol	Test Conditions	Min	Typ	Max	Unit	
Average Operating Current	I_{CC1}	Cycle time=1 μ s, 100% duty, I_{IO} =0mA, $CS1\# \leq 0.2V$, $LB\# \leq 0.2V$ and/or $UB\# \leq 0.2V$, $CS2 \geq V_{CC} - 0.2V$, $V_{IN} \leq 0.2V$ or $V_{IN} \geq V_{CC} - 0.2V$	—	—	TBD	mA	
	I_{CC2}	Async	Cycle time=Min, I_{IO} =0mA, 100% duty, $CS1\# = V_{IL}$, $CS2 = V_{IH}$ $LB\# = V_{IL}$ and/or $UB\# = V_{IL}$, $V_{IN} = V_{IH}$ or V_{IL}	—	—	TBD	mA
		Page	Cycle time= $t_{RC} + 3t_{PC}$, I_{IO} =0mA, 100% duty, $CS1\# = V_{IL}$, $CS2 = V_{IH}$ $LB\# = V_{IL}$ and/or $UB\# = V_{IL}$, $V_{IN} = V_{IH}$ or V_{IL}			TBD	mA
Standby Current (CMOS)	I_{SB1} (Note 1)	Other inputs=0-VCC 1. $CS1\# \geq V_{CC} - 0.2$, $CS2 \geq V_{CC} - 0.2V$ ($CS1\#$ controlled) or 2. $0V \leq CS2 \leq 0.2V$ ($CS2$ controlled)	—	—	TBD	mA	

Notes:

- Standby mode is supposed to be set up after at least one active operation after power up. I_{SB1} is measure after 60ms from the time when standby mode is set up.

AC Operating Conditions

Test Conditions (Test Load and Test Input/Output Reference)

- Input pulse level: 0.4 to 2.2V
- Input rising and falling time: 5ns
- Input and output reference voltage: 1.5V
- Output load (See Figure 25): $CL = 50pF$

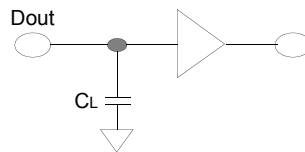

Figure 25. Output Load

Note: Including scope and jig capacitance.

ACC Characteristics (Ta = -40°C to 85°C, VCC = 2.7 to 3.1 V)

Symbol	Parameter	Speed Bins		Unit	
		70ns			
		Min	Max		
Read	t _{RC}	Read Cycle Time	70	—	ns
	t _{AA}	Address Access Time	—	70	ns
	t _{CO}	Chip Select to Output	—	70	ns
	t _{OE}	Output Enable to Valid Output	—	35	ns
	t _{BA}	UB#, LB# Access Time	—	70	ns
	t _{LZ}	Chip Select to Low-Z Output	10	—	ns
	t _{BLZ}	UB#, LB# Enable to Low-Z Output	10	—	ns
	t _{OLZ}	Output Enable to Low-Z Output	5	—	ns
	t _{HZ}	Chip Disable to High-Z Output	0	25	ns
	t _{BHZ}	UB#, LB# Disable to High-Z Output	0	25	ns
	t _{OHZ}	Output Disable to High-Z Output	0	25	ns
	t _{OH}	Output Hold from Address Change	5	—	ns
	t _{PC}	Page Cycle Time	25	—	ns
	t _{PA}	Page Access Time	—	20	ns
Write	t _{WC}	Write Cycle Time	70	—	ns
	t _{CW}	Chip Select to End of Write	60	—	ns
	t _{AS}	Address Set-up Time	0	—	ns
	t _{AW}	Address Valid to End of Write	60	—	ns
	t _{BW}	UB#, LB# Valid to End of Write	60	—	ns
	t _{WP}	Write Pulse Width	55 (Note 1)	—	ns
	t _{WR}	Write Recovery Time	0	—	ns
	t _{WHZ}	Write to Output High-Z	0	25	ns
	t _{DW}	Data to Write Time Overlap	30	—	ns
	t _{DH}	Data Hold from Write Time	0	—	ns
t _{OW}	End Write to Output Low-Z	5	—	ns	

Notes:

1. t_{WP} (min)=70ns for continuous write operation over 50 times.

Timing Diagrams

Read Timings

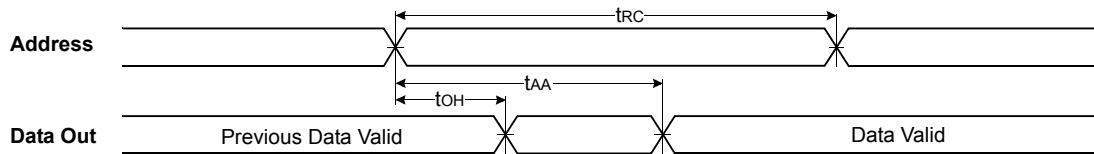

Figure 26. Timing Waveform of Read Cycle(1)

Notes:

1. Address Controlled, CS1# = OE# = V_{IL} , CS2 = WE# = V_{IH} , UB# and/or LB# = V_{IL} .

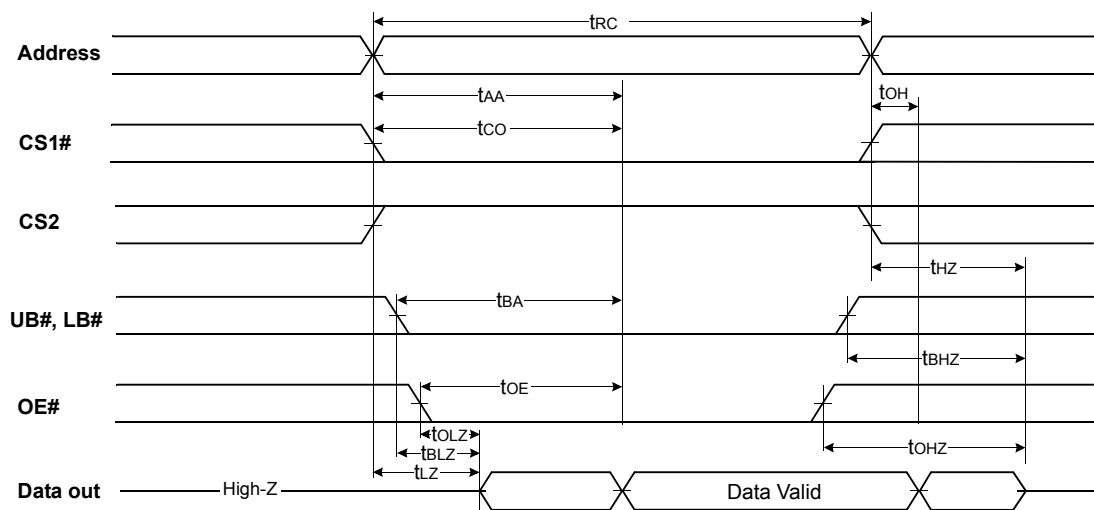

Figure 27. Timing Waveform of Read Cycle(2)

Notes:

1. WE# = V_{IH} .

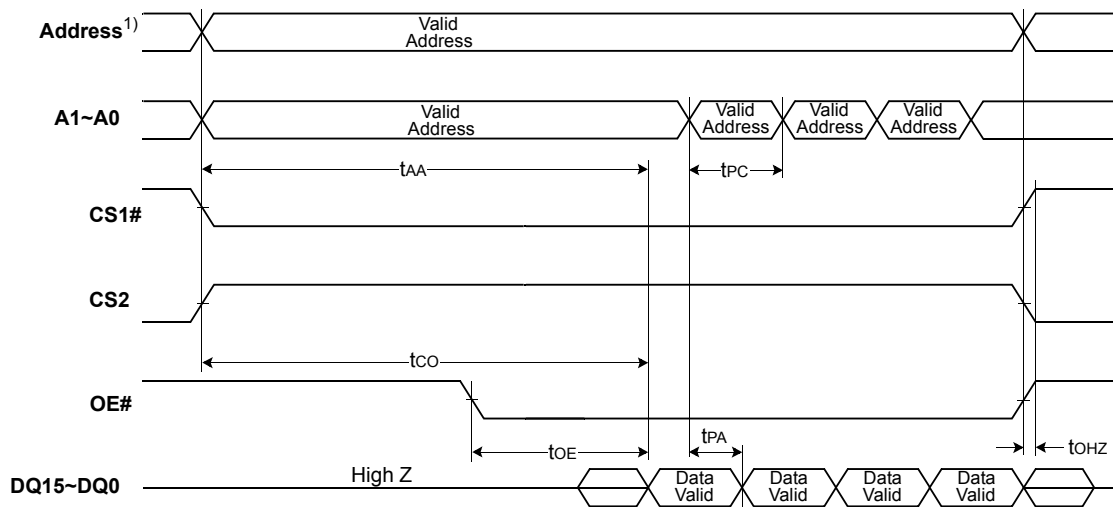

Figure 28. Timing Waveform of Read Cycle(2)

Notes:

1. 16Mb: A2 ~ A19, 32Mb: A2 ~ A20, 64Mb: A2 ~ A21.

t_{HZ} and t_{OHZ} are defined as the time at which the outputs achieve the open circuit conditions and are not referenced to output voltage levels.

At any given temperature and voltage condition, $t_{HZ}(Max.)$ is less than $t_{LZ}(Min.)$ both for a given device and from device to device interconnection.

$t_{OE}(max)$ is met only when OE# becomes enabled after $t_{AA}(max)$.

If invalid address signals shorter than min. t_{RC} are continuously repeated for over $4\mu s$, the device needs a normal read timing (t_{RC}) or needs to sustain standby state for min. t_{RC} at least once in every $4\mu s$.

Write Timings

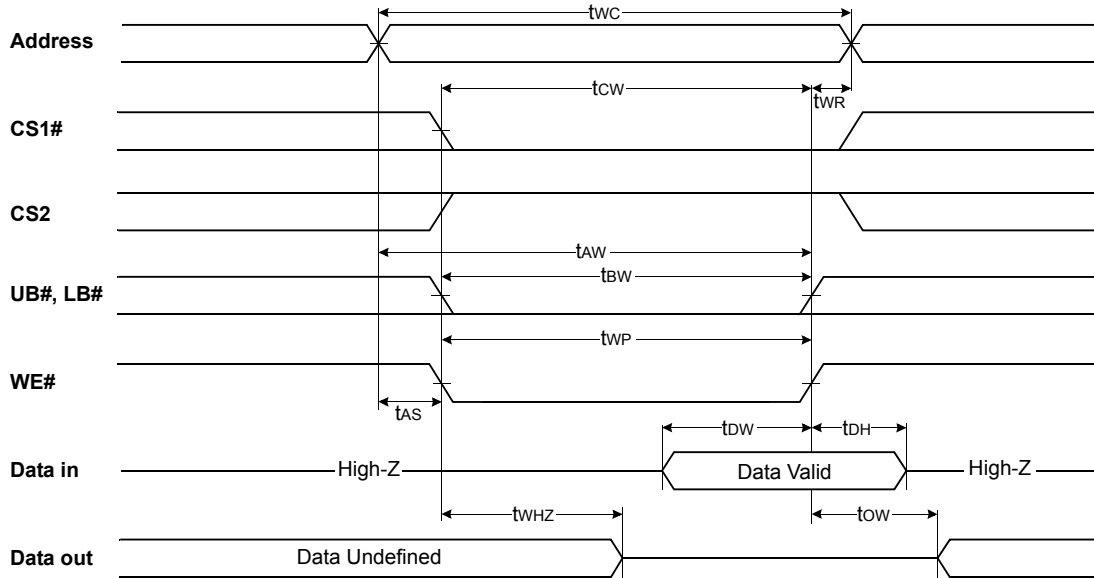

Figure 29. Write Cycle #1 (WE# Controlled)

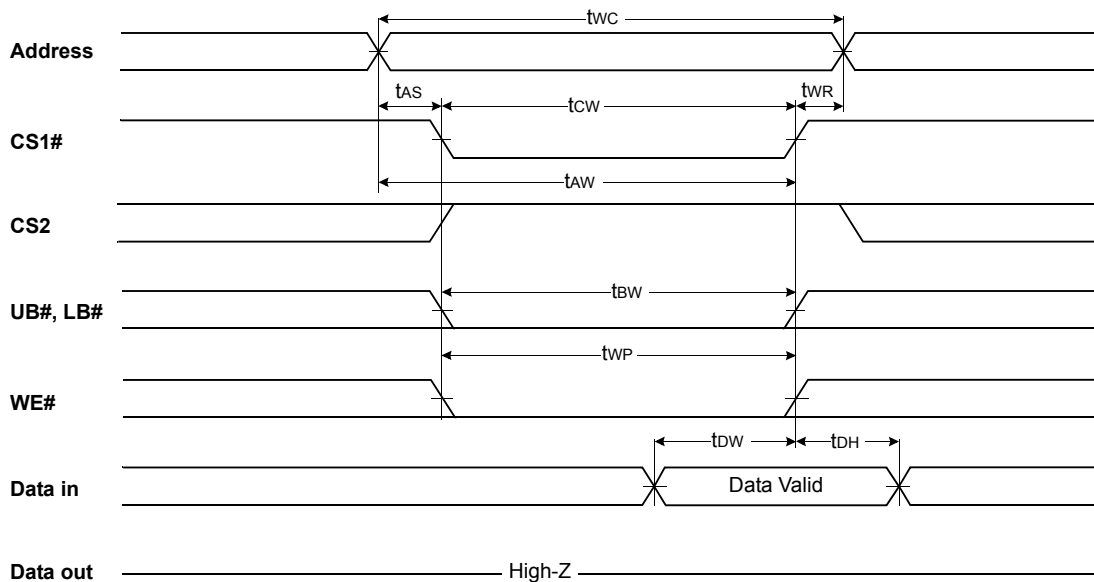

Figure 30. Write Cycle #2 (CS1# Controlled)

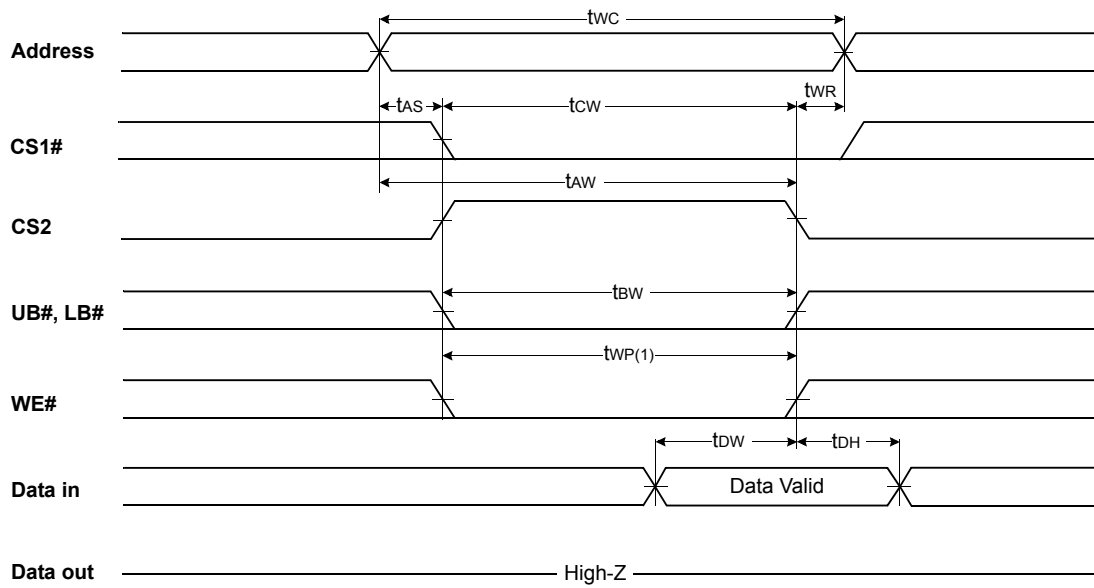

Figure 31. Timing Waveform of Write Cycle(3) (CS2 Controlled)

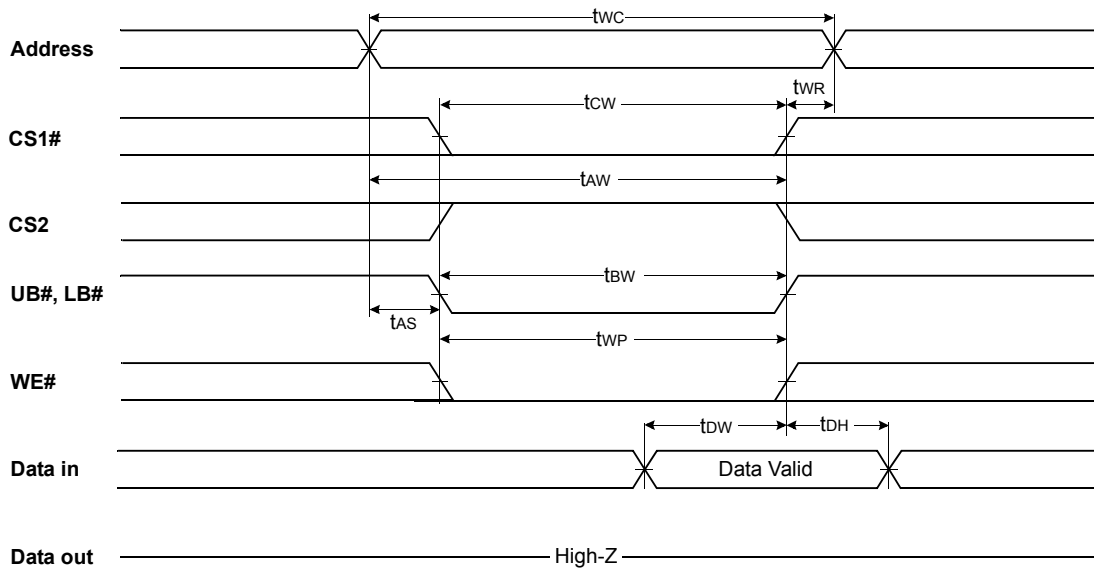

Figure 32. Timing Waveform of Write Cycle(4) (UB#, LB# Controlled)

Notes:

1. A write occurs during the overlap(t_{WP}) of low CS1# and low WE#. A write begins when CS1# goes low and WE# goes low with asserting UB# or LB# for single byte operation or simultaneously asserting UB# and LB# for double byte operation. A write ends at the earliest transition when CS1# goes high and WE# goes high. The t_{WP} is measured from the beginning of write to the end of write.
2. t_{CW} is measured from the CS1# going low to the end of write.
3. t_{AS} is measured from the address valid to the beginning of write.
4. t_{WR} is measured from the end of write to the address change. t_{WR} is applied in case a write ends with CS1# or WE# going high.

pSRAM Type 3

16 Megabit (1M x 16) CMOS Pseudo SRAM

Features

- Organized as 1M words by 16 bits
- Fast Cycle Time: 70 ns
- Standby Current: 100 μ A
- Deep power-down Current: 10 μ A (Memory cell data invalid)
- Byte data control: LB# (DQ0 - 7), UB# (DQ8 - 15)
- Compatible with low-power SRAM
- Single Power Supply Voltage: 3.0V \pm 0.3V

Description

pSRAM Type 3 currently includes only a 16M bit device, organized as 1M words by 16 bits. It is designed with advanced CMOS technology specified RAM featuring low-power static RAM-compatible function and pin configuration. This device operates from a single power supply. Advanced circuit technology provides both high speed and low power. It is automatically placed in low-power mode when CS1# or both UB# and LB# are asserted high or CS2 is asserted low. There are three control inputs. CS1# and CS2 are used to select the device, and output enable (OE#) provides fast memory access. Data byte control pins (LB#,UB#) provide lower and upper byte access. This device is well suited to various micro-processor system applications where high speed, low power and battery backup are required.

Pin Description

A0 – A19	=	Address Inputs
DQ0 – DQ15	=	Data Inputs/Outputs
CE1#	=	Chip Enable
CE2	=	Deep Power Down
OE#	=	Output Enable
WE#	=	Write Control
LB#	=	Lower Byte Control
UB#	=	Upper Byte Control
VCC	=	Power Supply
VSS	=	Ground

Operation Mode

MODE	CE1#	CE2	OE#	WE#	LB#	UB#	DQ0 to DQ7	DQ8 to DQ15	POWER
Deselect	H	H	X	X	X	X	High-Z	High-Z	Standby
Deselect	X	L	X	X	X	X	High-Z	High-Z	Deep Power Down
Deselect	L	H	X	X	H	H	High-Z	High-Z	Standby
Output Disabled	L	H	H	H	L	X	High-Z	High-Z	Active
Output Disabled	L	H	H	H	X	L	High-Z	High-Z	Active
Lower Byte Read	L	H	L	H	L	H	D-out	High-Z	Active
Upper Byte Read	L	H	L	H	H	L	High-Z	D-out	Active
Word Read	L	H	L	H	L	L	D-out	D-out	Active
Lower Byte Write	L	H	X	L	L	H	D-in	High-Z	Active
Upper Byte Write	L	H	X	L	H	L	High-Z	D-in	Active
Word Write	L	H	X	L	L	L	D-in	D-in	Active

Note: X = don't care. H = logic high. L = logic low.

Absolute Maximum Ratings (see Note)

SYMBOL	RATING	VALUE	UNIT
V_{CC}	Supply Voltage	-0.2 to +3.6	V
V_{IN}	Input Voltages	-0.2 to $V_{CC} + 0.3$	V
V_{IN}, V_{OUT}	Output and output Voltages	-2.0 to +3.6	V
I_{SH}	Output short circuit current	100	mA
P_D	Power Dissipation	1	W

Note: Absolute maximum DC requirements contains stress ratings only. Functional operation at the absolute maximum limits is not implied or guaranteed. Extended exposure to maximum ratings may affect device reliability.

DC Characteristics

Table 30. DC Recommended Operating Conditions

SYMBOL	PARAMETER	MIN	TYP.	MAX	UNIT
V_{DD}	Power Supply Voltage	2.7	3.0	3.3	V
V_{SS}	Ground	0	-	0	
V_{IH}	Input High Voltage	2.2	-	$V_{CC} + 0.2$ (Note 1)	
V_{IL}	Input Low Voltage	-0.2 (Note 2)	-	+0.6	

Notes:

1. Overshoot: $V_{CC} + 2.0V$ in case of pulse width $\leq 20ns$
2. Undershoot: $-2.0V$ in case of pulse width $\leq 20ns$
3. Overshoot and undershoot are sampled, not 100% tested.

Table 31. DC Characteristics ($T_A = -25^{\circ}\text{C}$ to 85°C , $V_{DD} = 2.6$ to 3.3V)

SYMBOL	PARAMETER	TEST CONDITION	MIN	MAX	UNIT
I_{IL}	Input Leakage Current	$V_{IN} = V_{SS}$ to V_{DD}	-1	1	μA
I_{LO}	Output Leakage Current	$V_{IO} = V_{SS}$ to V_{DD} CE1# = V_{IH} , CE2 = V_{IL} or OE# = V_{IH} or WE# = V_{IL}	-1	1	μA
I_{CC1}	Operating Current @ Min. Cycle Time	Cycle time = Min., 100% duty, $I_{IO} = 0\text{mA}$, CE1# = V_{IL} , CE2 = V_{IH} , $V_{IN} = V_{IH}$ or V_{IL}	-	35	mA
I_{CC2}	Operating Current @ Max Cycle Time	Cycle time = $1\mu\text{s}$, 100% duty $I_{IO} = 0\text{mA}$, CE1# $\leq 0.2\text{V}$, CE2 $\geq V_{DD} - 0.2\text{V}$, $V_{IN} \leq 0.2\text{V}$ or $V_{IN} \geq V_{DD} - 0.2\text{V}$	-	5	mA
I_{SB1}	Standby Current (CMOS)	CE1# = $V_{DD} - 0.2\text{V}$ and CE2 = $V_{DD} - 0.2\text{V}$, Other inputs = $V_{SS} \sim V_{CC}$	-	100	μA
I_{SBD}	Deep Power-down	CE2 $\leq 0.2\text{V}$, Other inputs = $V_{SS} \sim V_{CC}$	-	10	μA
V_{OL}	Output Low Voltage	$I_{OL} = 2.1\text{mA}$	-	0.4	V
V_{OH}	Output High Voltage	$I_{OH} = -1.0\text{mA}$	2.4	-	V

AC Characteristics

Table 32. AC Characteristics and Operating Conditions ($T_A = -25^{\circ}\text{C}$ to 85°C , $V_{DD} = 2.6$ to 3.3V)

Cycle	Symbol	Parameter	70		Unit
			Min	Max	
Read	t_{RC}	Read Cycle Time	70	-	ns
	t_{AA}	Address Access Time	-	70	ns
	t_{CO1}	Chip Enable (CE#1) Access Time	-	70	ns
	t_{CO2}	Chip Enable (CE2) Access Time	-	70	ns
	t_{OE}	Output Enable Access Time	-	35	ns
	t_{BA}	Data Byte Control Access Time	-	70	ns
	t_{LZ}	Chip Enable Low to Output in Low-Z	10	-	ns
	t_{OLZ}	Output Enable Low to Output in Low-Z	5	-	ns
	t_{BLZ}	Data Byte Control Low to Output in Low-Z	10	-	ns
	t_{HZ}	Chip Enable High to Output in High-Z	-	25	ns
	t_{OHZ}	Output Enable High to Output in High-Z	-	25	ns
	t_{BHZ}	Data Byte Control High to Output in High-Z	-	25	ns
t_{OH}	Output Data Hold Time	10	-	ns	

Table 32. AC Characteristics and Operating Conditions ($T_A = -25^{\circ}\text{C}$ to 85°C , $V_{DD} = 2.6$ to 3.3V) (Continued)

Cycle	Symbol	Parameter	70		Unit
			Min	Max	
Write	t_{WC}	Write Cycle Time	70	-	ns
	t_{WP}	Write Pulse Width	50	-	ns
	t_{AW}	Address Valid to End of Write	60	-	ns
	t_{CW}	Chip Enable to End of Write	60	-	ns
	t_{BW}	Data Byte Control to End of Write	60	-	ns
	t_{AS}	Address Set-up Time	0	-	ns
	t_{WR}	Write Recovery Time	0	-	ns
	t_{WZH}	WE# Low to Output High-Z	-	20	ns
	t_{OW}	WE# High to Output in High-Z	5	-	ns
	t_{DW}	Data to Write Overlap	35	-	ns
	t_{DH}	Data Hold Time	0	-	ns
	t_{WEH}	WE# High Time	5	10	ns

Table 33. AC Test Conditions

Parameter	Condition
Output load	50 pF + 1 TTL Gate
Input pulse level	0.4 V, 2.4
Timing measurements	$0.5 \times V_{CC}$
t_R, t_F	5 ns

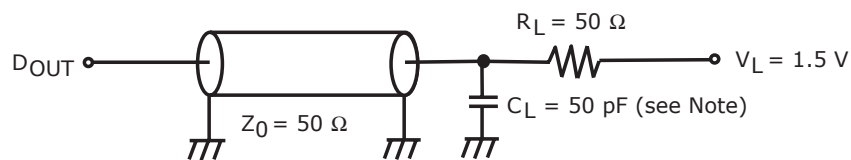

Note: Including scope and jig capacitance

Figure 33. AC Test Loads

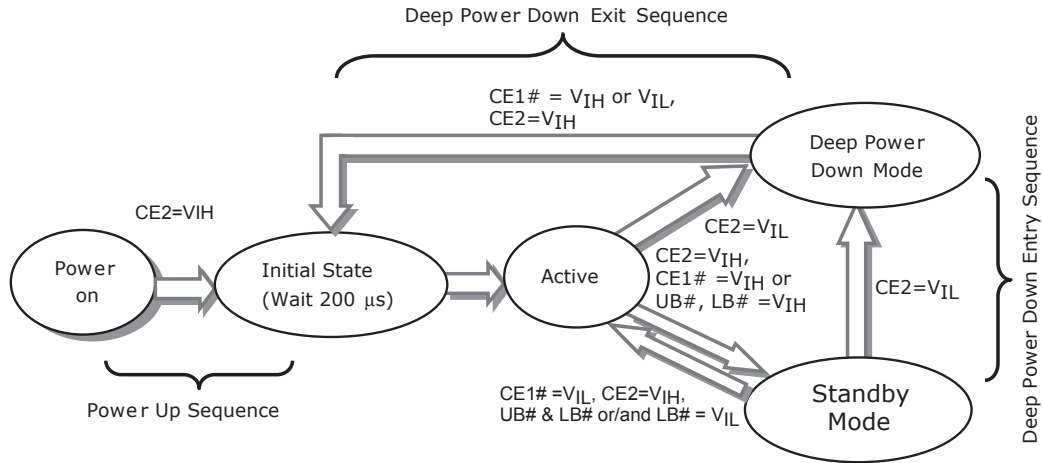
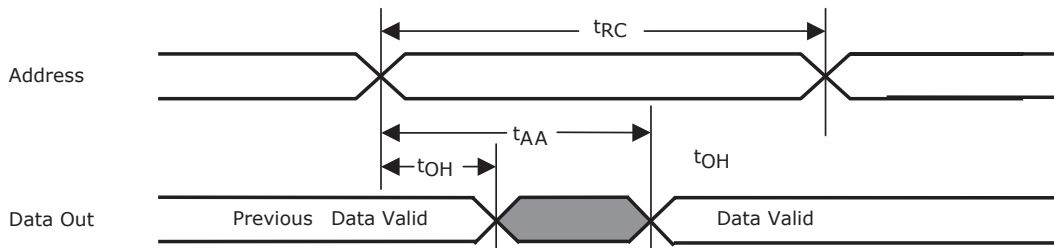

Figure 34. State Diagram

Table 34. Standby Mode Characteristics

Power Mode	Memory Cell Data	Standby Current (μA)	Wait Time (μs)
Standby	Valid	100	0
Deep Power Down	Invalid	10	200

Timing Diagrams



Note: CE1# = OE# = VIL, CE2 = WE# = VIH, UB# and/or LB# = VIL

Figure 35. Read Cycle I—Addressed Controlled

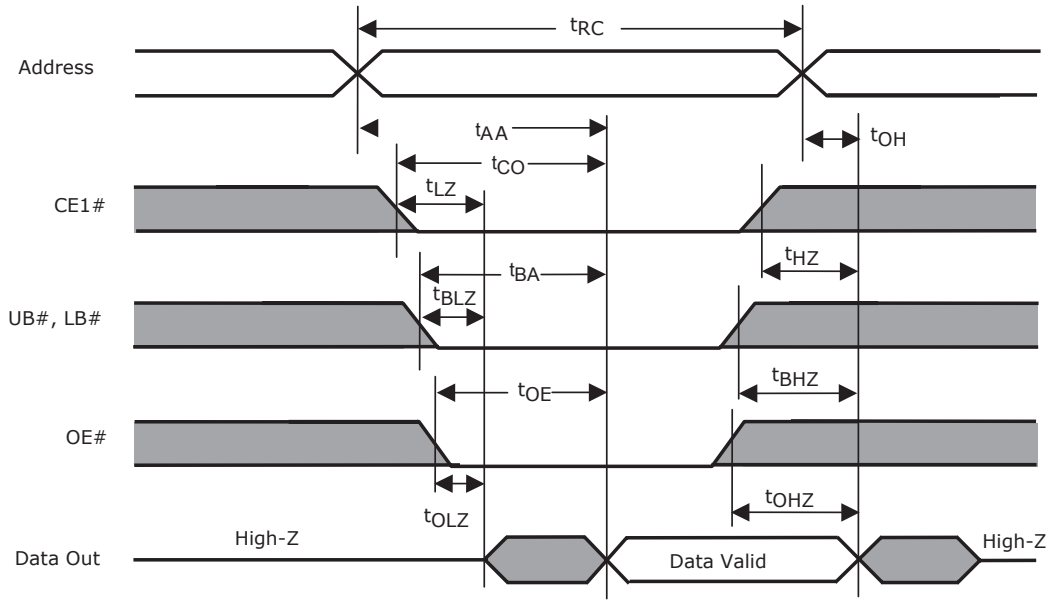

Note: CE2 = WE# = V_{IH}

Figure 36. Read Cycle 2—CSI# Controlled

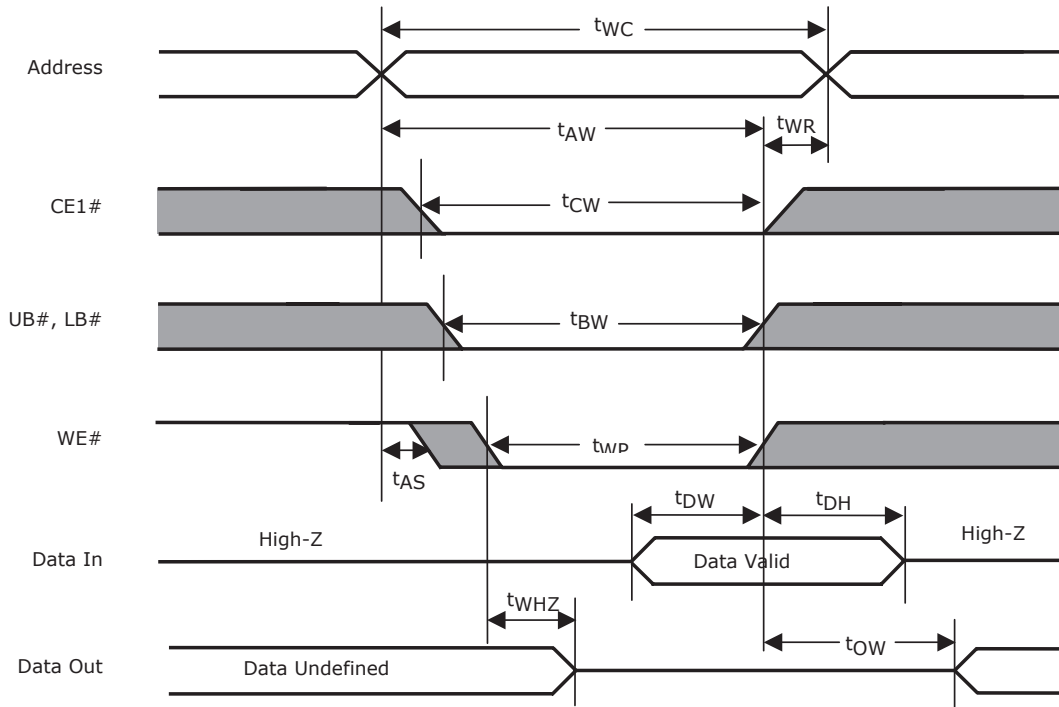

Notes:

1. CE2 = V_{IH}
2. CE2 = WE# = V_{IH}

Figure 37. Write Cycle I—WE# Controlled

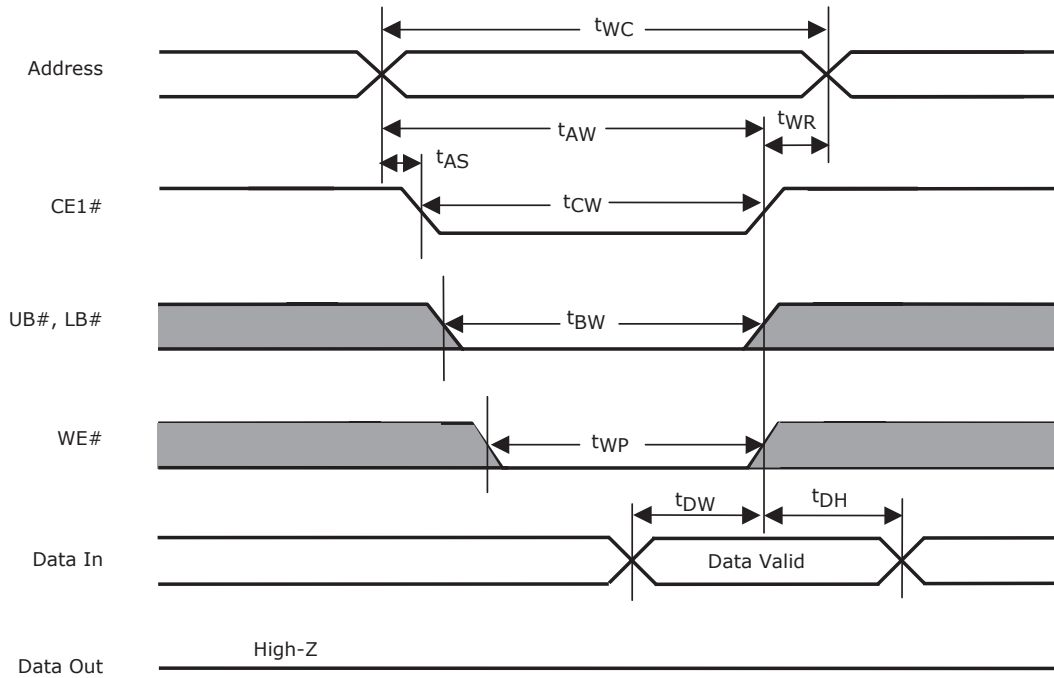

Notes:

1. $CE2 = V_{IH}$
2. $CE2 = WE\# = V_{IH}$

Figure 38. Write Cycle 2—CSI# Controlled

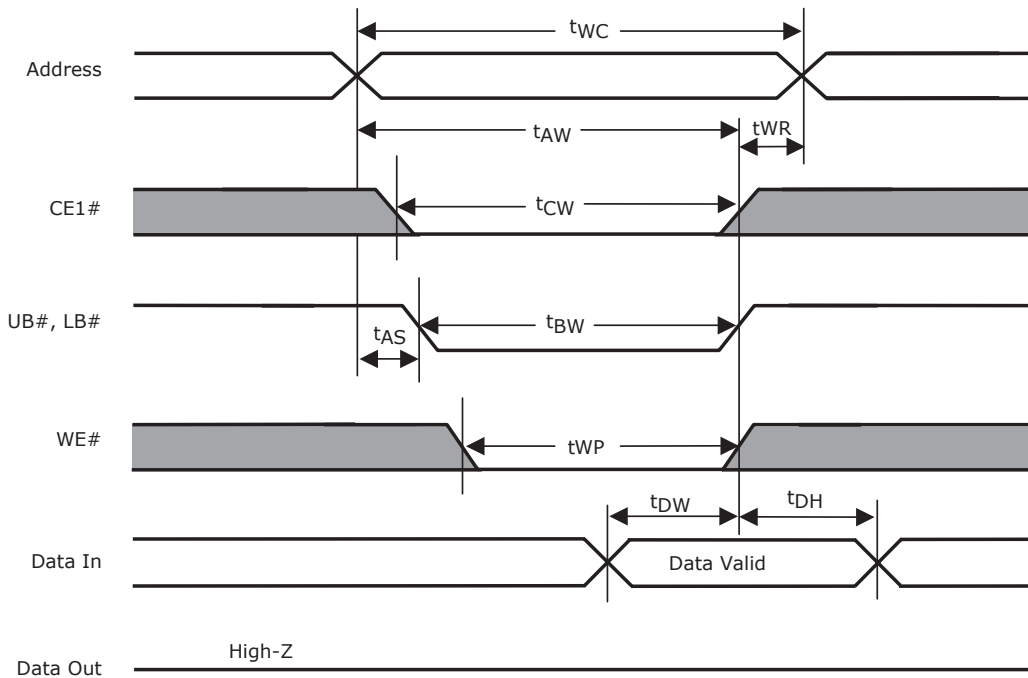

Notes:

1. $CE2 = V_{IH}$
2. $CE2 = WE\# = V_{IH}$

Figure 39. Write Cycle 3—UB#, LB# Controlled

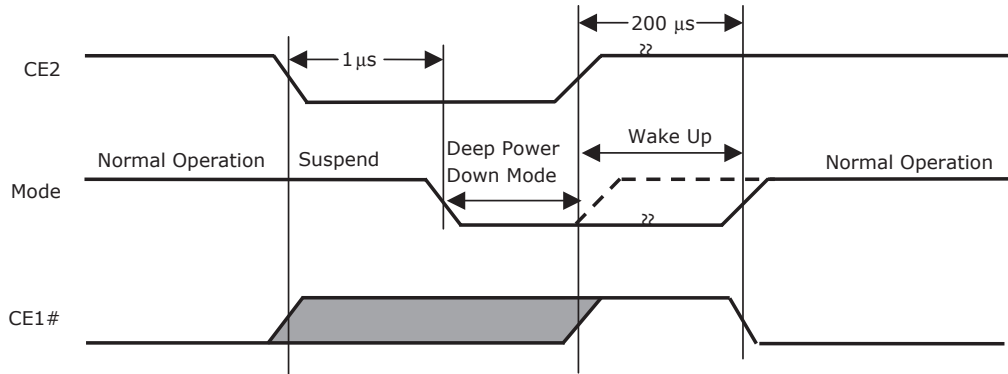

Figure 40. Deep Power-down Mode

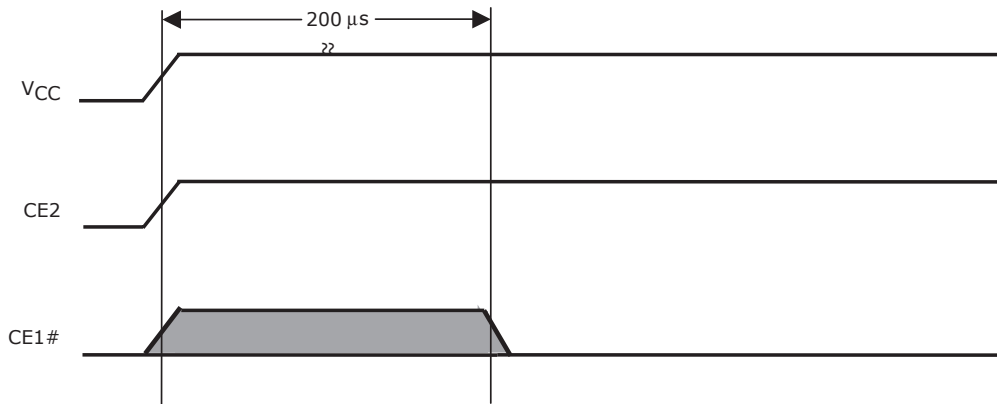
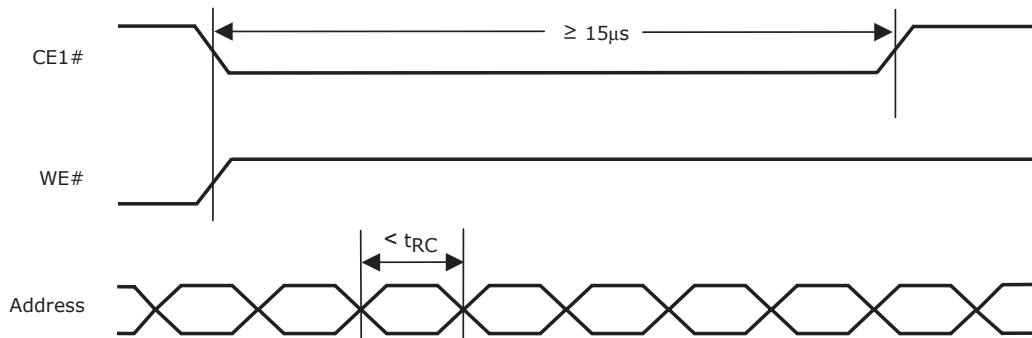

Figure 41. Power-up Mode



Note: The S71JL064HA0 Model 61 has a timing that is not supported at read operation. Data will be lost if your system has multiple invalid address signal shorter than t_{RC} during over $15\mu s$ at the read operation shown above.

Figure 42. Abnormal Timing

pSRAM Type 4

4 Mbit (256K x 16)

Features

- Wide voltage range: 2.7V to 3.3V
- Typical active current: 3 mA @ f = 1 MHz
- Low standby power
- Automatic power-down when deselected

Functional Description

The Type 4 pSRAM is a high-performance CMOS pseudo static RAM (pSRAM) organized as 256K words by 16 bits that supports an asynchronous memory interface. This device features advanced circuit design to provide ultra-low active current. The device can be put into standby mode reducing power consumption dramatically when deselected (CE1# Low, CE2 High or both BHE# and BLE# are High). The input/output pins (I/O0 through I/O15) are placed in a high-impedance state when: deselected (CE1# High, CE2 Low, OE# is deasserted High), or during a write operation (Chip Enabled and Write Enable WE# Low). Reading from the device is accomplished by asserting the Chip Enables (CE1# Low and CE2 High) and Output Enable (OE#) Low while forcing the Write Enable (WE#) High. If Byte Low Enable (BLE#) is Low, then data from the memory location specified by the address pins will appear on I/O0 to I/O7. If Byte High Enable (BHE#) is Low, then data from memory will appear on I/O8 to I/O15. See [Table 37](#) for a complete description of read and write modes.

Product Portfolio

V _{CC} Range (V)			Speed (ns)	Power Dissipation					
				Operating, I _{CC} (mA)				Standby (I _{SB2}) (μA)	
				f = 1 MHz		f = f _{max}			
Min	Typ	Max	Typ. (note 1)	Max	Typ. (note 1)	Max	Typ. (note 1)	Max	
2.7V	3.0V	3.3V	70 ns	3	5	TBD	25 mA	15	40

Notes:

1. Typical values are included for reference only and are not guaranteed or tested. Typical values are measured at V_{CC} = V_{CC} (typ) and T_A = 25°C.

Maximum Ratings

(Above which the useful life may be impaired. For user guidelines, not tested)

Storage Temperature	-65°C to +150°C
Ambient Temperature with Power Applied	-40°C to +85°C
Supply Voltage to Ground Potential	-0.4V to 4.6V
DC Voltage Applied to Outputs in High-Z State (note 1, 2, 3)	-0.4V to 3.7V
DC Input Voltage (note 1, 2, 3)	-0.4V to 3.7V
Output Current into Outputs (Low)	20 mA
Static Discharge Voltage	>2001V (per MIL-STD-883, Method 3015)
Latch-up Current	>200 mA

Notes:

1. $V_{IH(MAX)} = V_{CC} + 0.5V$ for pulse durations less than 20 ns.
2. $V_{IL(MIN)} = -0.5V$ for pulse durations less than 20 ns.
3. Overshoot and undershoot specifications are characterized and are not 100% tested.

Operating Range

Ambient Temperature (T_A)	V_{CC}
-25°C to +85°C	2.7V to 3.3V

Table 35. DC Electrical Characteristics (Over the Operating Range)

Parameter	Description	Test Conditions	Min.	Typ. (note 1)	Max	Unit	
V_{CC}	Supply Voltage		2.7		3.3	V	
V_{OH}	Output High Voltage	$I_{OH} = -1.0$ mA	$V_{CC} - 0.4$				
V_{OL}	Output Low Voltage	$I_{OL} = 0.1$ mA			0.4		
V_{IH}	Input High Voltage		$0.8 * V_{CC}$		$V_{CC} + 0.4$		
V_{IL}	Input Low Voltage	$F = 0$	-0.4		0.4		
I_{IX}	Input Leakage Current	$GND \leq V_{IN} \leq V_{CC}$	-1		+1	μ A	
I_{OZ}	Output Leakage Current	$GND \leq V_{OUT} \leq V_{CC}$, Output Disabled	-1		+1		
I_{CC}	V_{CC} Operating Supply Current	$f = f_{MAX} = 1/t_{RC}$ $f = 1$ MHz	$V_{CC} = 3.3V$ $I_{OUT} = 0$ mA CMOS Levels		TBD	15	mA
						3	
I_{SB1}	Automatic CE# Power-Down Current—CMOS Inputs	$CE\# \geq V_{CC} - 0.2V$, $CE2 \leq 0.2V$ $V_{IN} \geq V_{CC} - 0.2V$, $V_{IN} \leq 0.2V$, $f = f_{max}$ (Address and Data Only), $f=0$ (OE#, WE#, BHE# and BLE#)			250	μ A	
I_{SB2}	Automatic CE# Power-Down Current—CMOS Inputs	$CE\# \geq V_{CC} - 0.2V$, $CE2 \leq 0.2V$ $V_{IN} \geq V_{CC} - 0.2V$ or $V_{IN} \leq 0.2V$, $f = 0$, $V_{CC} = 3.3V$			40		

Notes:

1. Typical values are included for reference only and are not guaranteed or tested. Typical values are measured at $V_{CC} = V_{CC(typ.)}$, $T_A = 25^\circ C$.

Capacitance

Parameter	Description	Test Condition	Max	Unit
C_{IN}	Input Capacitance	$T_A = 25^\circ\text{C}, f = 1 \text{ MHz},$ $V_{CC} = V_{CC(\text{typ.})}$	8	pF
C_{OUT}	Output Capacitance		8	

Note: Tested initially and after any design or process changes that may affect these parameters.

Thermal Resistance

Parameter	Description	Test Conditions	VFBGA	Unit
θ_{JA}	Thermal Resistance (Junction to Ambient)	Test conditions follow standard test methods and procedures for measuring thermal impedance, per EIA / JESD51.	55	$^\circ\text{C}/\text{W}$
θ_{JC}	Thermal Resistance (Junction to Case)		17	

Note: Tested initially and after any design or process changes that may affect these parameters.

AC Test Loads and Waveforms

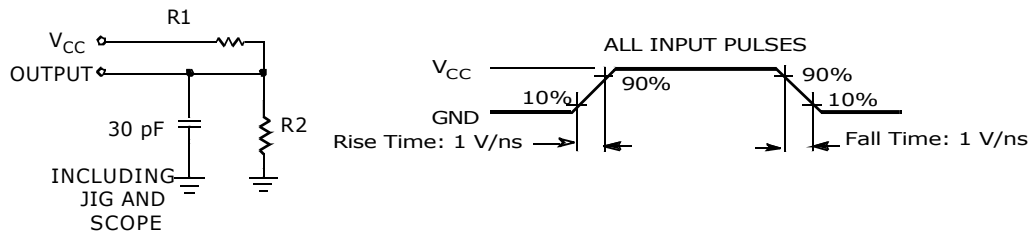

Equivalent to: THÉVENINEQUIVALENT

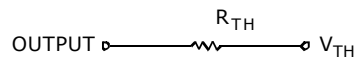

Figure 43. AC Test Loads and Waveforms

Parameters	3.0V V_{CC}	Unit
R1	22000	Ω
R2	22000	
R_{TH}	11000	
V_{TH}	1.50	V

Table 36. Switching Characteristics

Parameter	Description	Min	Max	Unit
Read Cycle				
t_{RC}	Read Cycle Time	70		ns
t_{AA}	Address to Data Valid		70	
t_{OHA}	Data Hold from Address Change	10		
t_{ACE}	CE#1 Low and CE2 High to Data Valid		70	
t_{DOE}	OE# Low to Data Valid		35	
t_{LZOE}	OE# Low to Low Z (note 2, 3)	5		
t_{HZOE}	OE# High to High Z (note 2, 3)		25	
t_{LZCE}	CE#1 Low and CE2 High to Low Z (note 2, 3)	5		
t_{HZCE}	CE#1 High and CE2 Low to High Z (note 2, 3)		25	
t_{DBE}	BHE# / BLE# Low to Data Valid		70	
t_{LZBE}	BHE# / BLE# Low to Low Z (note 2, 3)	5		
t_{HZBE}	BHE# / BLE# High to High Z (note 2, 3)		25	
t_{SK} (note 4)	Address Skew		10	
Write Cycle (note 5)				
t_{WC}	Write Cycle Time	70		ns
t_{SCE}	CE#1 Low and CE2 High to Write End	55		
t_{AW}	Address Set-Up to Write End	55		
t_{HA}	Address Hold from Write End	0		
t_{SA}	Address Set-Up to Write Start	0		
t_{PWE}	WE# Pulse Width	55		
t_{BW}	BLE# / BHE# LOW to Write End	55		
t_{SD}	Data Set-up to Write End	25		
t_{HD}	Data Hold from Write End	0		
t_{HZWE}	WE# Low to High Z (note 2, 3)		25	
t_{LZWE}	WE# High to Low Z (note 2, 3)	5		

Notes:

1. Test conditions assume signal transition time of 1V/ns or higher, timing reference levels of $V_{CC(typ.)}/2$, input pulse levels of 0 to $V_{CC(typ.)}$, and output loading of the specified I_{OL}/I_{OH} and 30 pF load capacitance.
2. t_{HZOE} , t_{HZCE} , t_{HZBE} and t_{HZWE} transitions are measured when the outputs enter a high-impedance state.
3. High-Z and Low-Z parameters are characterized and are not 100% tested.
4. To achieve 55-ns performance, the read access should be CE# controlled. In this case t_{ACE} is the critical parameter and t_{SK} is satisfied when the addresses are stable prior to chip enable going active. For the 70-ns cycle, the addresses must be stable within 10 ns after the start of the read cycle.
5. The internal write time of the memory is defined by the overlap of $WE\#$, $CE\#1 = V_{IL}$, $CE2 = V_{IH}$, BHE and/or $BLE = V_{IL}$. All signals must be Active to initiate a write and any of these signals can terminate a write by going Inactive. The data input set-up and hold timing should be referenced to the edge of the signal that terminates write.

Switching Waveforms

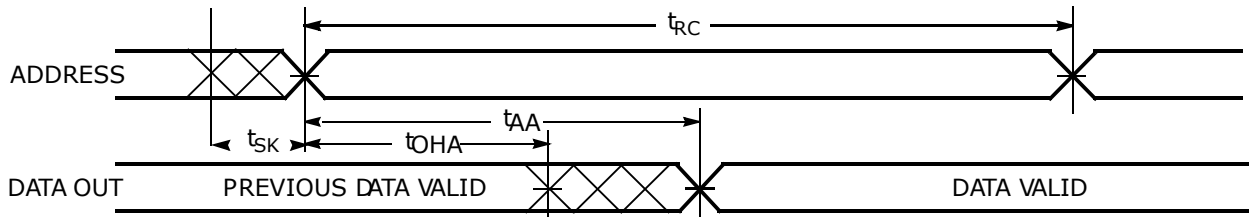

Figure 44. Read Cycle I (Address Transition Controlled)

Notes:

1. To achieve 55-ns performance, the read access should be CE# controlled. In this case t_{ACE} is the critical parameter and t_{SK} is satisfied when the addresses are stable prior to chip enable going active. For the 70-ns cycle, the addresses must be stable within 10 ns after the start of the read cycle.
2. Device is continuously selected. OE#, CE# = V_{IL} .
3. WE# is High for Read Cycle.

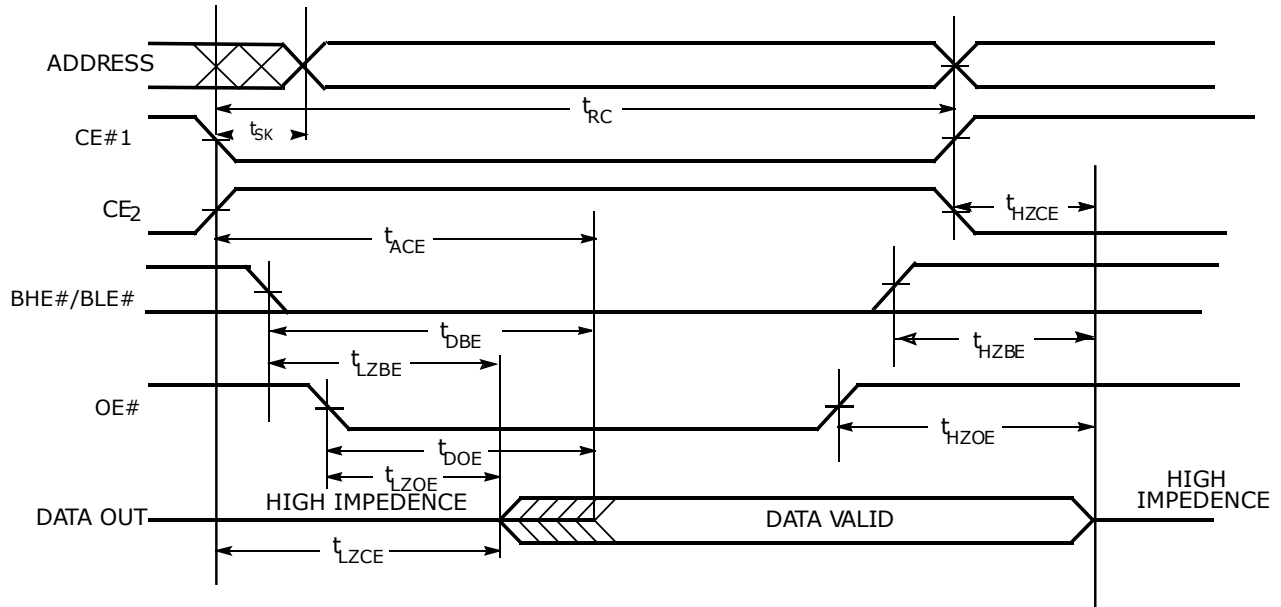

Figure 45. Read Cycle 2 (OE# Controlled)

Notes:

1. To achieve 55-ns performance, the read access should be CE# controlled. In this case t_{ACE} is the critical parameter and t_{SK} is satisfied when the addresses are stable prior to chip enable going active. For the 70-ns cycle, the addresses must be stable within 10 ns after the start of the read cycle.
2. WE# is High for Read Cycle.

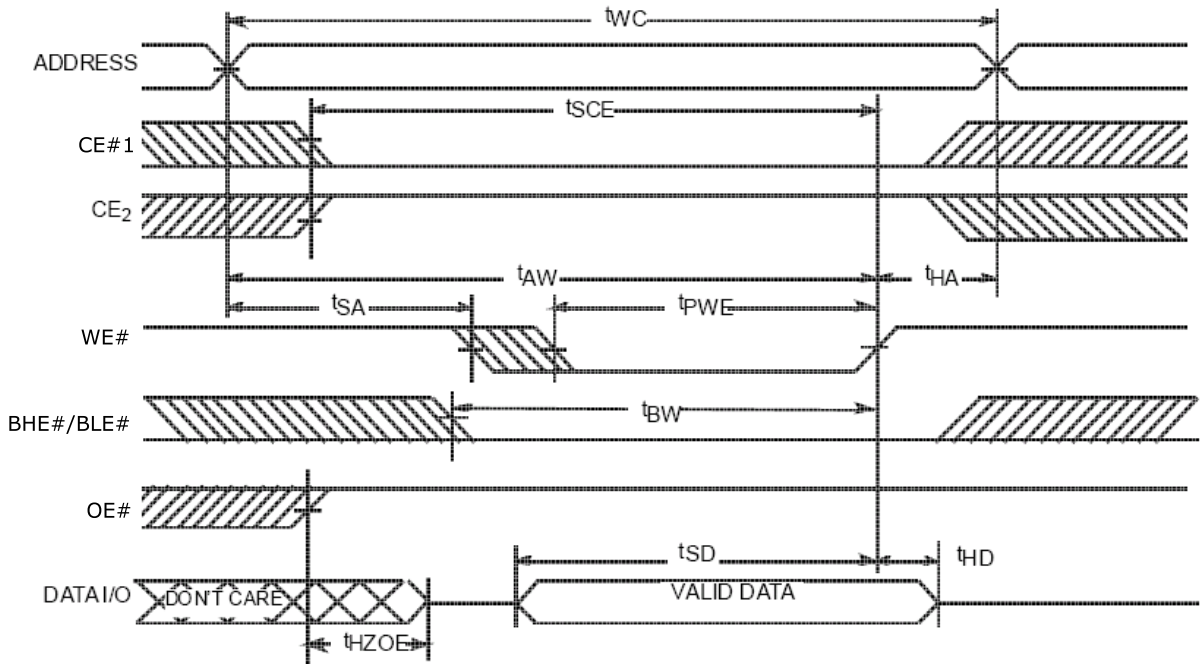

Figure 46. Write Cycle I (WE# Controlled)

Notes:

1. High-Z and Low-Z parameters are characterized and are not 100% tested.
2. The internal write time of the memory is defined by the overlap of WE#, CE#1 = V_{IL} , CE2 = V_{IH} , BHE and/or BLE = V_{IL} . All signals must be Active to initiate a write and any of these signals can terminate a write by going Inactive. The data input set-up and hold timing should be referenced to the edge of the signal that terminates write.
3. Data I/O is high impedance if OE# $\geq V_{IH}$.
4. If Chip Enable goes Inactive simultaneously with WE# = High, the output remains in a high-impedance state.
5. During the Don't Care period in the Data I/O waveform, the I/Os are in output state and input signals should not be applied.

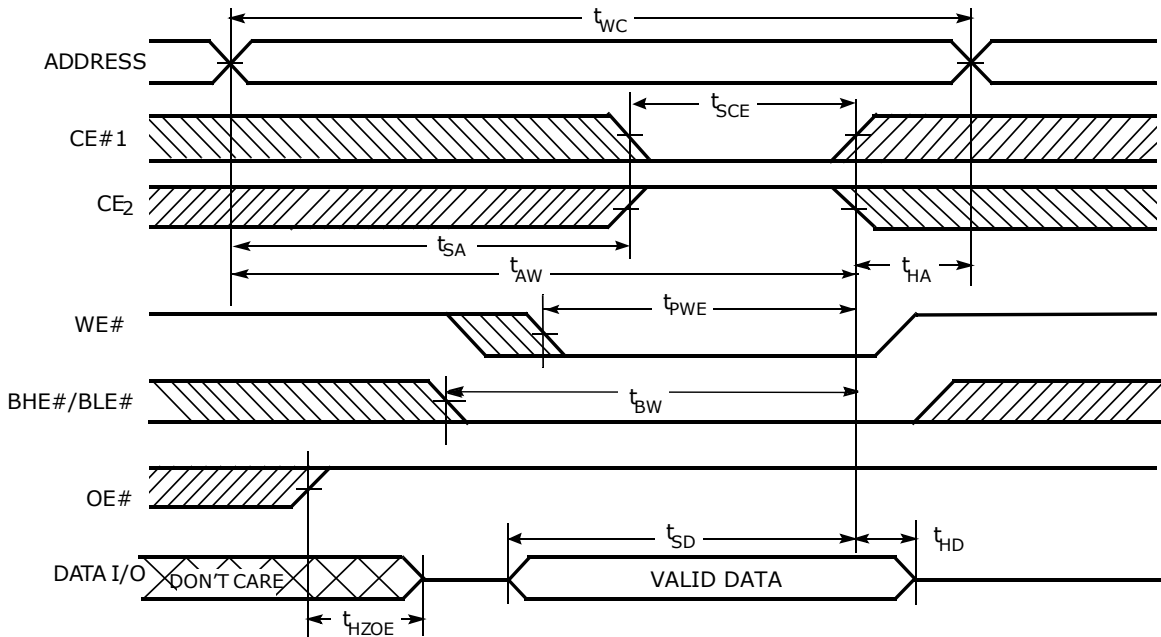

Figure 47. Write Cycle 2 (CE#1 or CE2 Controlled)

Notes:

1. High-Z and Low-Z parameters are characterized and are not 100% tested.
2. The internal write time of the memory is defined by the overlap of WE#, CE#1 = V_{IL} , CE2 = V_{IH} , B_{HE} and/or B_{LE} = V_{IL} . All signals must be Active to initiate a write and any of these signals can terminate a write by going Inactive. The data input set-up and hold timing should be referenced to the edge of the signal that terminates write.
3. Data I/O is high impedance if OE# $\geq V_{IH}$.
4. If Chip Enable goes Inactive simultaneously with WE# = High, the output remains in a high-impedance state.
5. During the Don't Care period in the Data I/O waveform, the I/Os are in output state and input signals should not be applied.

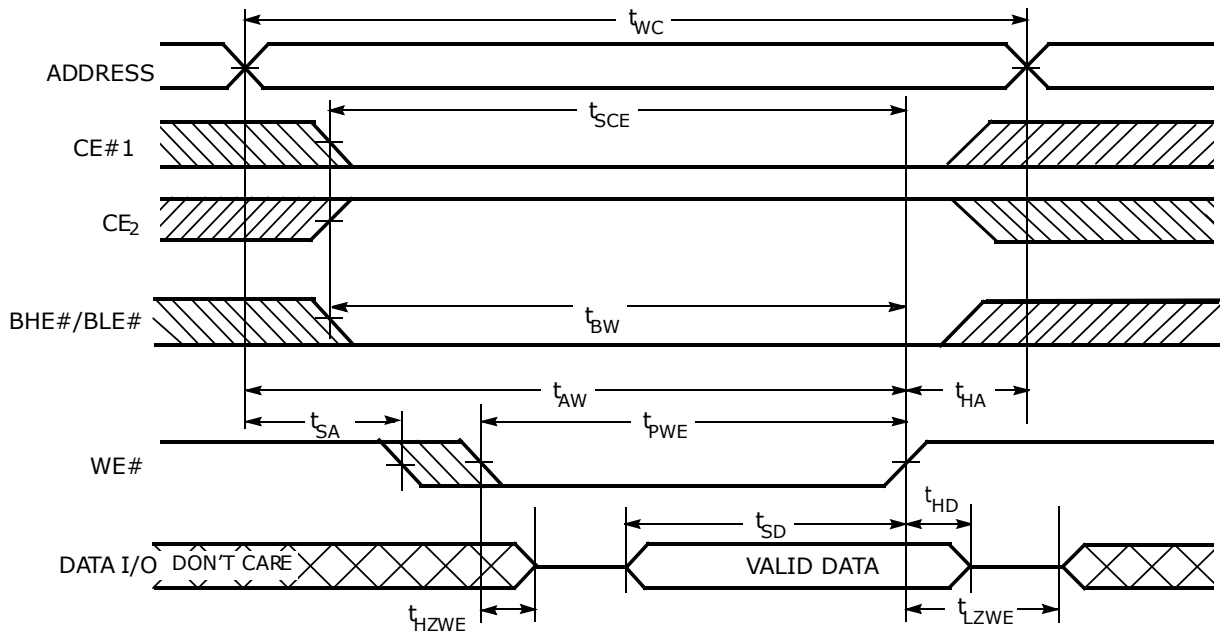

Figure 48. Write Cycle 3 (WE# Controlled, OE# Low)

Notes:

1. If Chip Enable goes Inactive simultaneously with WE# = High, the output remains in a high-impedance state.
2. During the Don't Care period in the Data I/O waveform, the I/Os are in output state and input signals should not be applied.

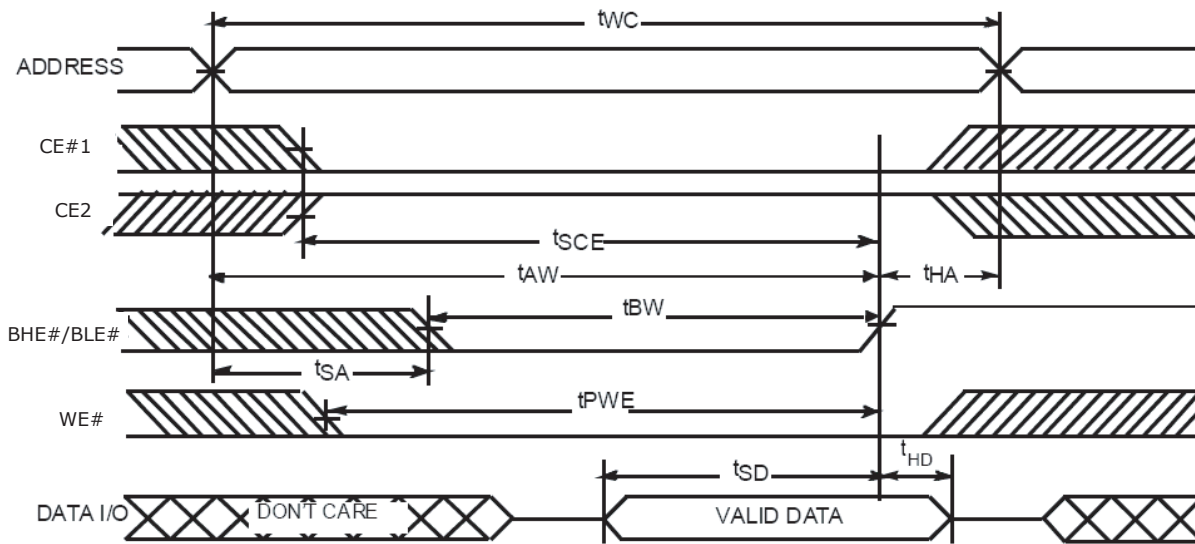

Figure 49. Write Cycle 4 (BHE#/BLE# Controlled, OE# Low)

Notes:

1. If Chip Enable goes Inactive simultaneously with WE# = High, the output remains in a high-impedance state.
2. During the Don't Care period in the Data I/O waveform, the I/Os are in output state and input signals should not be applied.

Truth Table

Table 37. Truth Table

CE#1	CE2	WE#	OE#	BHE#	BLE#	Inputs / Outputs	Mode	Power
H	X	X	X	X	X	High-Z	Deselect/Power-Down	Standby (I_{SB})
X	L	X	X	X	X	High-Z		
X	X	X	X	H	H	High-Z		
L	H	H	L	L	L	Data Out (I/O0–I/O15)	Read (Upper Byte and Lower Byte)	Active (I_{CC})
L	H	H	L	H	L	Data Out (I/O0 –I/O7); I/O8–I/O15 in High Z	Read (Upper Byte only)	
L	H	H	L	L	H	Data Out (I/O8–I/O15); I/O0–I/O7 in High Z	Read (Lower Byte only)	
L	H	H	H	L	L	High-Z	Output Disabled	
L	H	H	H	H	L	High-Z	Output Disabled	
L	H	H	H	L	H	High-Z	Output Disabled	
L	H	L	X	L	L	Data In (I/O0–I/O15)	Write (Upper Byte and Lower Byte)	
L	H	L	X	H	L	Data In (I/O0–I/O7); I/O8–I/O15 in High Z	Write (Lower Byte Only)	
L	H	L	X	L	H	Data In (I/O8–I/O15); I/O0 –I/O7 in High Z	Write (Upper Byte Only)	

pSRAM Type 6

2M Word by 16-bit Cmos Pseudo Static RAM (32M Density)
4M Word by 16-bit Cmos Pseudo Static RAM (64M Density)

Features

- Single power supply voltage of 2.6 to 3.3 V
- Direct TTL compatibility for all inputs and outputs
- Deep power-down mode: Memory cell data invalid
- Page operation mode:
 - Page read operation by 8 words
- Logic compatible with SRAM R/W () pin
- Standby current
 - Standby = 70 μ A (32M)
 - Standby = 100 μ A (64M)
 - Deep power-down Standby = 5 μ A
- Access Times

	32M 64M
Access Time	70 ns
CE1# Access Time	70 ns
OE# Access Time	25 ns
Page Access Time	30 ns

Pin Description

Pin Name	Description
A ₀ to A ₂₁	Address Inputs
A0 to A2	Page Address Inputs
I/O1 to I/O16	Data Inputs/Outputs
CE1#	Chip Enable Input
CE2	Chip select Input
WE#	Write Enable Input
OE#	Output Enable Input
LB#,UB#	Data Byte Control Inputs
V _{DD}	Power Supply
GND	Ground
NC	Not Connection

Functional Description

Mode	CE1#	CE2	OE#	WE#	LB#	UB#	Address	I/O ₁₋₈	I/O ₉₋₁₆	Power
Read (Word)	L	H	L	H	L	L	X	D _{OUT}	D _{OUT}	I _{DDO}
Read (Lower Byte)	L	H	L	H	L	H	X	D _{OUT}	High-Z	I _{DDO}
Read (Upper Byte)	L	H	L	H	H	L	X	High-Z	D _{OUT}	I _{DDO}
Write (Word)	L	H	X	L	L	L	X	D _{IN}	D _{IN}	I _{DDO}
Write (Lower Byte)	L	H	X	L	L	H	X	D _{IN}	Invalid	I _{DDO}
Write (Upper Byte)	L	H	X	L	H	L	X	Invalid	D _{IN}	I _{DDO}
Outputs Disabled	L	H	H	H	X	X	X	High-Z	High-Z	I _{DDO}
Standby	H	H	X	X	X	X	X	High-Z	High-Z	I _{DDO}
Deep Power-down Standby	H	L	X	X	X	X	X	High-Z	High-Z	I _{DDSD}

Legend: L = Low-level Input (V_{IL}), H = High-level Input (V_{IH}), X = V_{IL} or V_{IH} , High-Z = High Impedance.

Absolute Maximum Ratings

Symbol	Rating	Value	Unit
V_{DD}	Power Supply Voltage	-1.0 to 3.6	V
V_{IN}	Input Voltage	-1.0 to 3.6	V
V_{OUT}	Output Voltage	-1.0 to 3.6	V
T_{opr}	Operating Temperature	-40 to 85	°C
T_{strg}	Storage Temperature	-55 to 150	°C
P_D	Power Dissipation	0.6	W
I_{OUT}	Short Circuit Output Current	50	mA

DC Recommended Operating Conditions ($T_a = -40^{\circ}\text{C}$ to 85°C)

Symbol	Parameter	Min	Typ	Max	Unit
V_{DD}	Power Supply Voltage	2.6	2.75	3.3	V
V_{IH}	Input High Voltage	2.0	—	$V_{DD} + 0.3$ (Note)	
V_{IL}	Input Low Voltage	-0.3 (Note)	—	0.4	

Note: V_{IH} (Max) $V_{DD} = 1.0$ V with 10 ns pulse width. V_{IL} (Min) -1.0 V with 10 ns pulse width.

DC Characteristics ($T_a = -40^{\circ}\text{C}$ to 85°C , $V_{DD} = 2.6$ to 3.3 V) (See Note 3 to 4)

Symbol	Parameter	Test Condition	Min	Typ.	Max	Unit	
I_{IL}	Input Leakage Current	$V_{IN} = 0$ V to V_{DD}	-1.0	—	+1.0	μA	
I_{LO}	Output Leakage Current	Output disable, $V_{OUT} = 0$ V to V_{DD}	-1.0	—	+1.0	μA	
V_{OH}	Output High Voltage	$I_{OH} = -0.5$ mA	2.0	$\frac{3}{4}$	V	V	
V_{OL}	Output Low Voltage	$I_{OL} = 1.0$ mA	—	—	0.4	V	
I_{DDO1}	Operating Current	$CE1\# = V_{IL}$, $CE2 = V_{IH}$, $I_{OUT} = 0$ mA, $t_{RC} = \text{min}$	ET5U28A-43DS	—	—	40	mA
			ET5VB5A-43DS	—	—	50	
I_{DDO2}	Page Access Operating Current	$CE1\# = V_{IL}$, $CE2 = V_{IH}$, $I_{OUT} = 0$ mA Page add. cycling, $t_{RC} = \text{min}$	—	—	25	mA	
I_{DDS}	Standby Current(MOS)	$CE1\# = V_{DD} - 0.2$ V, $CE2 = V_{DD} - 0.2$ V	ET5U28A-43DS	—	—	70	mA
			ET5VB5A-43DS	—	—	100	μA
I_{DDSD}	Deep Power-down Standby Current	$CE2 = 0.2$ V	—	—	5	μA	

Capacitance ($T_a = 25^{\circ}\text{C}$, $f = 1$ MHz)

Symbol	Parameter	Test Condition	Max	Unit
C_{IN}	Input Capacitance	$V_{IN} = \text{GND}$	10	pF
C_{OUT}	Output Capacitance	$V_{OUT} = \text{GND}$	10	pF

Note: This parameter is sampled periodically and is not 100% tested.

AC Characteristics and Operating Conditions

($T_a = -40^{\circ}\text{C}$ to 85°C , $V_{DD} = 2.6$ to 3.3 V) (See Note 5 to II)

Symbol	Parameter	Min	Max	Unit
t_{RC}	Read Cycle Time	70	10000	ns
t_{ACC}	Address Access Time	—	70	ns
t_{CO}	Chip Enable (CE1#) Access Time	—	70	ns
t_{OE}	Output Enable Access Time	—	25	ns
t_{BA}	Data Byte Control Access Time	—	25	ns
t_{COE}	Chip Enable Low to Output Active	10	—	ns
t_{OEE}	Output Enable Low to Output Active	0	—	ns
t_{BE}	Data Byte Control Low to Output Active	0	—	ns
t_{OD}	Chip Enable High to Output High-Z	—	20	ns
t_{ODO}	Output Enable High to Output High-Z	—	20	ns
t_{BD}	Data Byte Control High to Output High-Z	—	20	ns

Symbol	Parameter	Min	Max	Unit
t _{OH}	Output Data Hold Time	10	—	ns
t _{PM}	Page Mode Time	70	10000	ns
t _{PC}	Page Mode Cycle Time	30	—	ns
t _{AA}	Page Mode Address Access Time	—	30	ns
t _{AOH}	Page Mode Output Data Hold Time	10	—	ns
t _{WC}	Write Cycle Time	70	10000	ns
t _{WP}	Write Pulse Width	50	—	ns
t _{CW}	Chip Enable to End of Write	70	—	ns
t _{BW}	Data Byte Control to End of Write	60	—	ns
t _{AW}	Address Valid to End of Write	60	—	ns
t _{AS}	Address Set-up Time	0	—	ns
t _{WR}	Write Recovery Time	0	—	ns
t _{CEH}	Chip Enable High Pulse Width	10	—	ns
t _{WEH}	Write Enable High Pulse Width	6	—	ns
t _{ODW}	WE# Low to Output High-Z	—	20	ns
t _{OEW}	WE# High to Output Active	0	—	ns
t _{DS}	Data Set-up Time	30	—	ns
t _{DH}	Data Hold Time	0	—	ns
t _{CS}	CE2 Set-up Time	0	—	ns
t _{CH}	CE2 Hold Time	300	—	μs
t _{DPD}	CE2 Pulse Width	10	—	ms
t _{CHC}	CE2 Hold from CE1#	0	—	ns
t _{CHP}	CE2 Hold from Power On	30	—	μs

AC Test Conditions

Parameter	Condition
Output load	30 pF + 1 TTL Gate
Input pulse level	V _{DD} - 0.2 V, 0.2 V
Timing measurements	V _{DD} × 0.5
Reference level	V _{DD} × 0.5
t _R , t _F	5 ns

Timing Diagrams

Read Timings

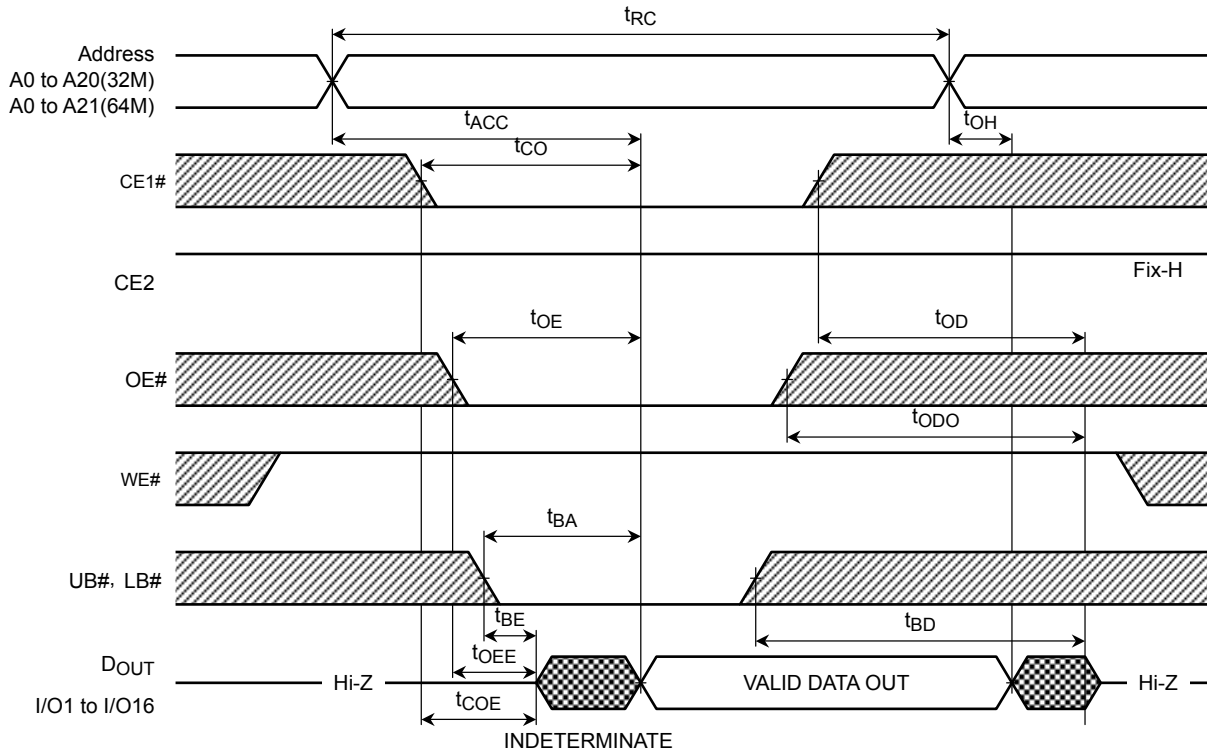

Figure 50. Read Cycle

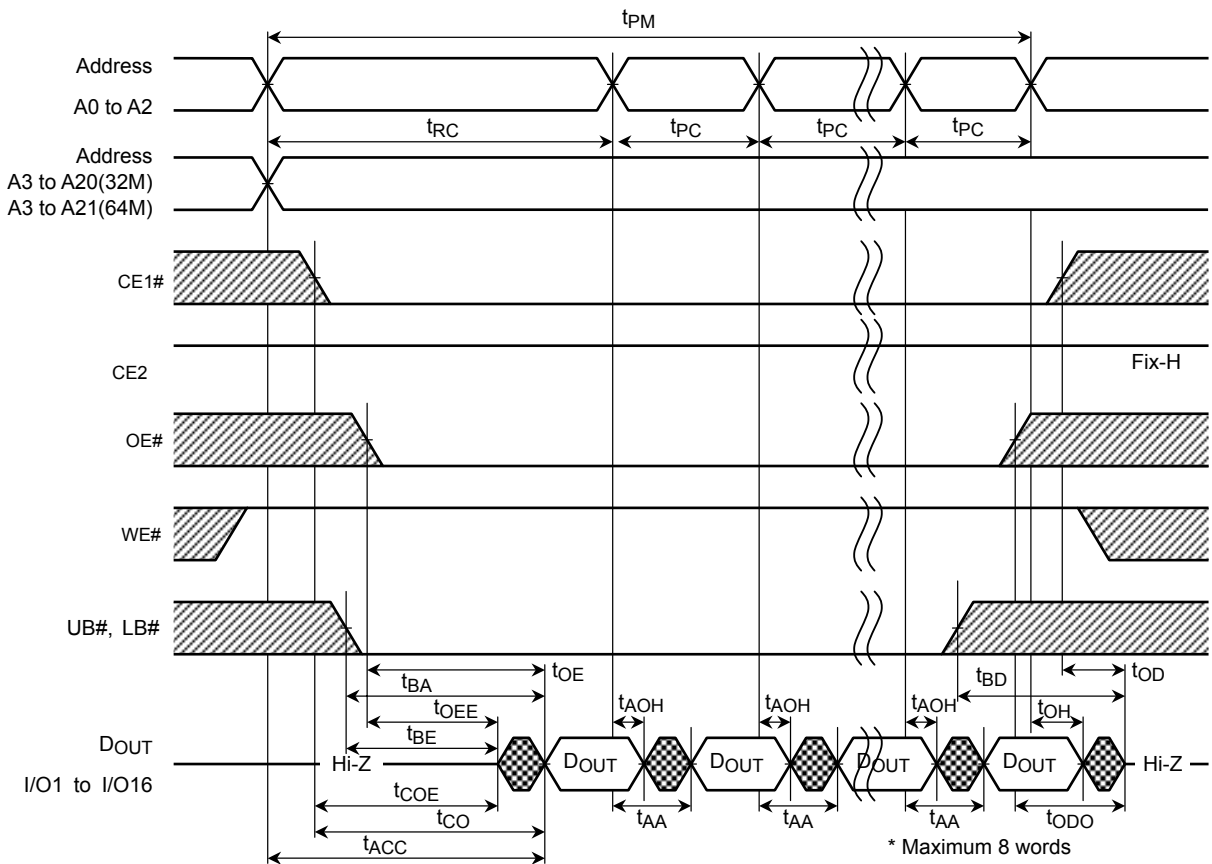

Figure 5I. Page Read Cycle (8 Words Access)

Write Timings

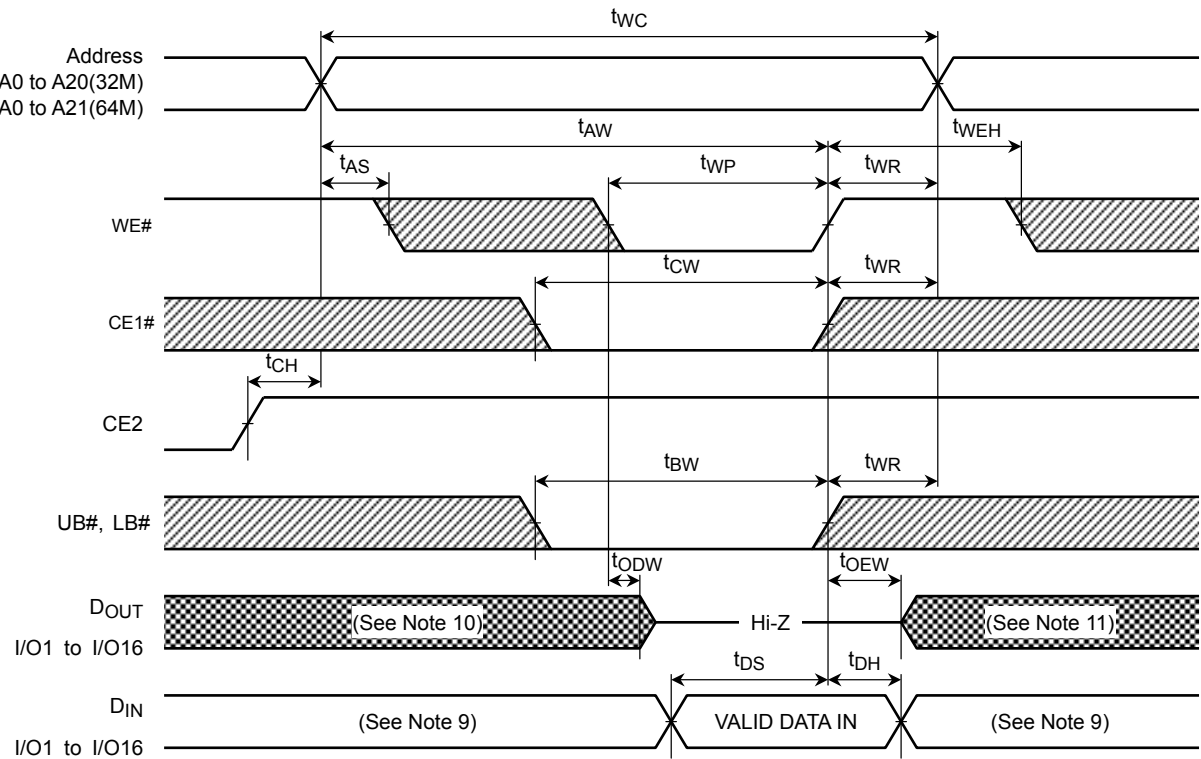

Figure 52. Write Cycle #1 ($WE\#$ Controlled) (See Note 8)

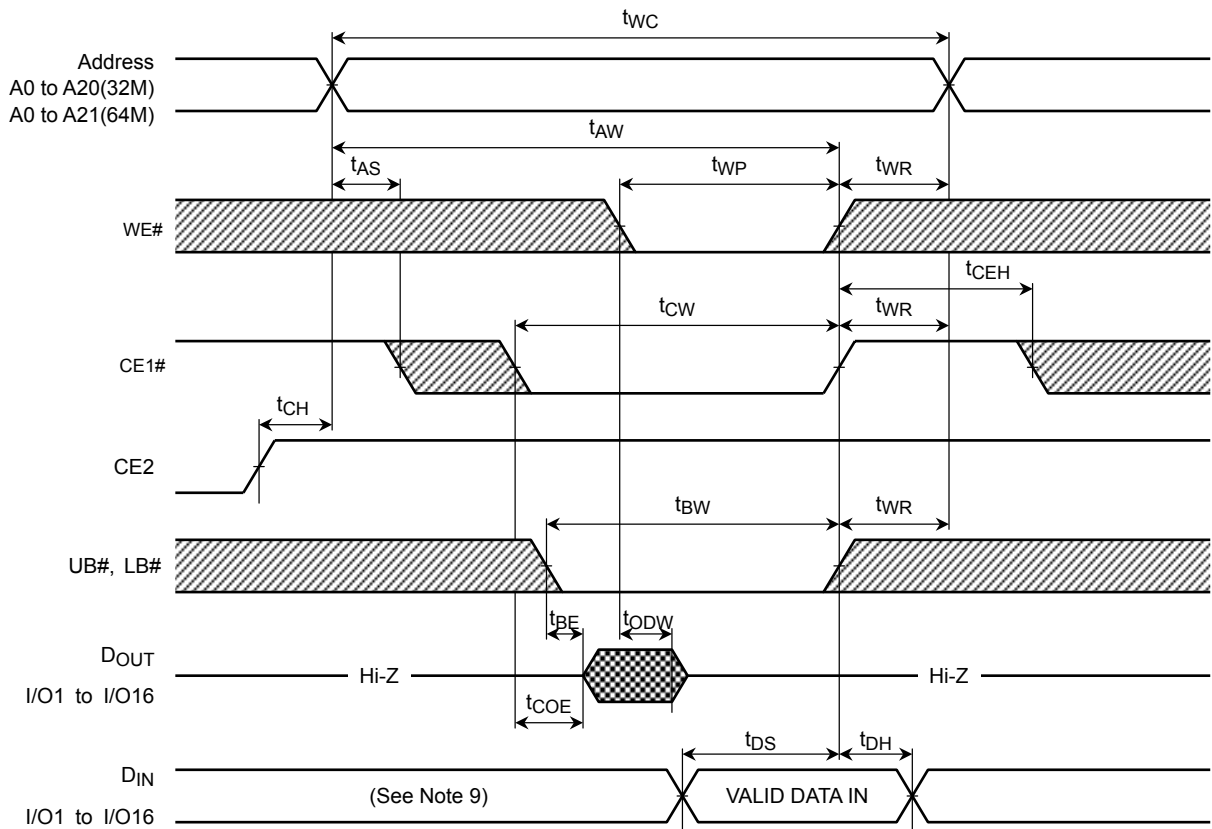

Figure 53. Write Cycle #2 (CE# Controlled) (See Note 8)

Deep Power-down Timing

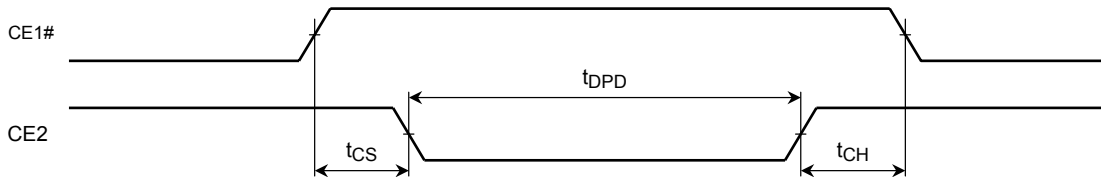

Figure 54. Deep Power Down Timing

Power-on Timing

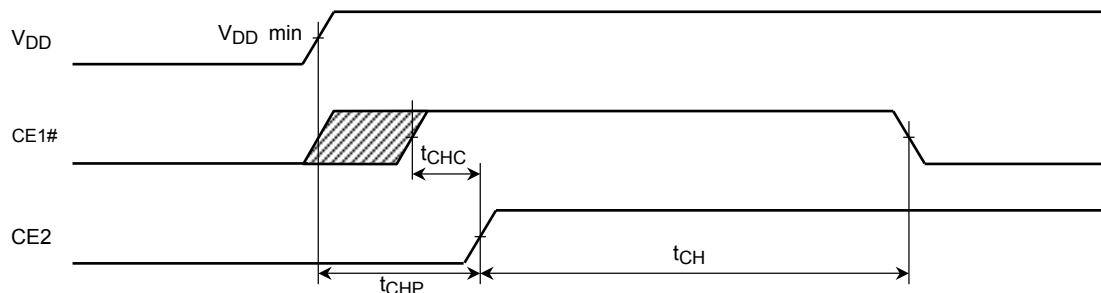

Figure 55. Power-on Timing

Provisions of Address Skew

Read

In case multiple invalid address cycles shorter than $t_{RC\ min}$ sustain over $10\ \mu\text{s}$ in an active status, at least one valid address cycle over $t_{RC\ min}$ is required during $10\ \mu\text{s}$.

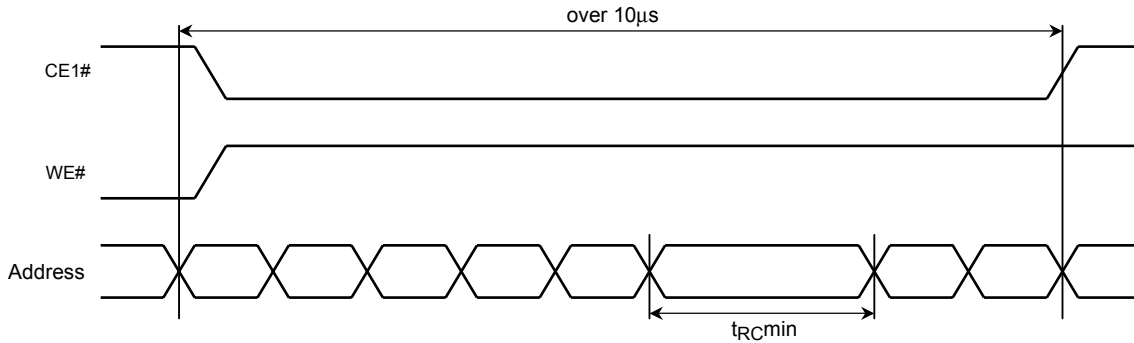

Figure 56. Read

Write

In case multiple invalid address cycles shorter than $t_{WC\ min}$ sustain over $10\ \mu\text{s}$ in an active status, at least one valid address cycle over $t_{WC\ min}$ is required during $10\ \mu\text{s}$.

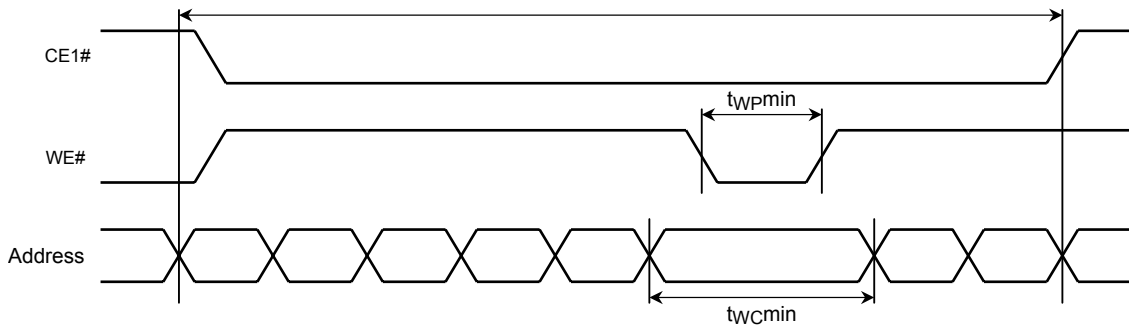

Figure 57. Write

Notes:

1. Stresses greater than listed under "Absolute Maximum Ratings" section may cause permanent damage to the device.
2. All voltages are reference to GND.
3. I_{DDO} depends on the cycle time.
4. I_{DDO} depends on output loading. Specified values are defined with the output open condition.
5. AC measurements are assumed $t_r, t_f = 5\ \text{ns}$.
6. Parameters t_{OD}, t_{ODO}, t_{BD} and t_{ODW} define the time at which the output goes the open condition and are not output voltage reference levels.
7. Data cannot be retained at deep power-down stand-by mode.
8. If OE# is high during the write cycle, the outputs will remain at high impedance.
9. During the output state of I/O signals, input signals of reverse polarity must not be applied.
10. If CE1# or LB#/UB# goes LOW coincident with or after WE# goes LOW, the outputs will remain at high impedance.
11. If CE1# or LB#/UB# goes HIGH coincident with or before WE# goes HIGH, the outputs will remain at high impedance.

pSRAM Type 7

CMOS 1M/2M/4M-Word x 16-bit Fast Cycle Random Access Memory with Low Power SRAM Interface

16Mb (1M word x 16-bit)

32Mb (2M word x 16-bit)

64Mb (4M word x 16-bit)

Features

- Asynchronous SRAM Interface
- Fast Access Time
 - $t_{CE} = t_{AA} = 60\text{ns}$ max (16M)
 - $t_{CE} = t_{AA} = 65\text{ns}$ max (32M/64M)
- 8 words Page Access Capability
 - $t_{PAA} = 20\text{ns}$ max (32M/64M)
- Low Voltage Operating Condition
 - $V_{DD} = +2.7\text{V}$ to $+3.1\text{V}$
- Wide Operating Temperature
 - $T_A = -30^\circ\text{C}$ to $+85^\circ\text{C}$
- Byte Control by LB and UB
- Various Power Down modes
 - Sleep (16M)
 - Sleep, 4M-bit Partial, or 8M-bit Partial (32M)
 - Sleep, 8M-bit Partial, or 16M-bit Partial (64M)

Pin Description

Pin Name	Description
A ₂₁ to A ₀	Address Input: A ₁₉ to A ₀ for 16M, A ₂₀ to A ₀ for 32M, A ₂₁ to A ₀ for 64M
CE1#	Chip Enable (Low Active)
CE2#	Chip Enable (High Active)
WE#	Write Enable (Low Active)
OE#	Output Enable (Low Active)
UB#	Upper Byte Control (Low Active)
LB#	Lower Byte Control (Low Active)
DQ ₁₆₋₉	Upper Byte Data Input/Output
DQ ₈₋₁	Lower Byte Data Input/Output
V _{DD}	Power Supply
V _{SS}	Ground

Functional Description

Mode	CE2#	CE1#	WE#	OE#	LB#	UB#	A ₂₁₋₀	DQ ₈₋₁	DQ ₁₆₋₉
Standby (Deselect)	H	H	X	X	X	X	X	High-Z	High-Z
Output Disable (Note 1)	H	L	H	H	X	X	Note 3	High-Z	High-Z
Output Disable (No Read)			H	L	H	H	Valid	High-Z	High-Z
Read (Upper Byte)					H	L	Valid	High-Z	Output Valid
Read (Lower Byte)					L	H	Valid	Output Valid	High-Z
Read (Word)					L	L	Valid	Output Valid	Output Valid
No Write			L	H	H	H	Valid	Invalid	Invalid
Write (Upper Byte)					H	L	Valid	Invalid	Input Valid
Write (Lower Byte)					L	H	Valid	Input Valid	Invalid
Write (Word)					L	L	Valid	Input Valid	Input Valid
Power Down			L	X	X	X	X	X	X

Legend: L = V_{IL} , H = V_{IH} , X can be either V_{IL} or V_{IH} , High-Z = High Impedance.

Notes:

- Should not be kept this logic condition longer than 1 ms. Please contact local Spansion representative for the relaxation of 1ms limitation.
- Power Down mode can be entered from Standby state and all DQ pins are in High-Z state. Data retention depends on the selection of the Power-Down Program, 16M has data retention in all modes except Power Down. Refer to Power Down for details.
- Can be either V_{IL} or V_{IH} but must be valid before Read or Write.

Power Down (for 32M, 64M Only)

Power Down

The Power Down is a low-power idle state controlled by CE2. CE2 Low drives the device in power-down mode and maintains the low-power idle state as long as CE2 is kept Low. CE2 High resumes the device from power-down mode. These devices have three power-down modes. These can be programmed by series of read/write operation. Each mode has following features.

32M			64M		
Mode	Retention Data	Retention Address	Mode	Retention Data	Retention Address
Sleep (default)	No	N/A	Sleep (default)	No	N/A
4M Partial	4M bit	00000h to 3FFFFh	8M Partial	8M bit	00000h to 7FFFFh
8M Partial	8M bit	00000h to 7FFFFh	16M Partial	16M bit	00000h to FFFFFh

The default state is Sleep and it is the lowest power consumption but all data is lost once CE2 is brought to Low for Power Down. It is not required to program to Sleep mode after power-up.

Power Down Program Sequence

The program requires 6 read/write operations with a unique address. Between each read/write operation requires that device be in standby mode. The following table shows the detail sequence.

Cycle #	Operation	Address	Data
1st	Read	3FFFFFFh (MSB)	Read Data (RDa)
2nd	Write	3FFFFFFh	RDa
3rd	Write	3FFFFFFh	RDa
4th	Write	3FFFFFFh	Don't Care (X)
5th	Write	3FFFFFFh	X
6th	Read	Address Key	Read Data (RDb)

The first cycle reads from the most significant address (MSB).

The second and third cycle are to write back the data (RDa) read by first cycle. If the second or third cycle is written into the different address, the program is cancelled, and the data written by the second or third cycle is valid as a normal write operation.

The fourth and fifth cycles write to MSB. The data from the fourth and fifth cycles is "don't care." If the fourth or fifth cycles are written into different address, the program is also cancelled but write data might not be written as normal write operation.

The last cycle is to read from specific address key for mode selection.

Once this program sequence is performed from a Partial mode to the other Partial mode, the written data stored in memory cell array can be lost. So, it should perform this program prior to regular read/write operation if Partial mode is used.

Address Key

The address key has following format.

Mode		Address				
32M	64M	A21	A20	A19	A18 - A0	Binary
Sleep (default)	Sleep (default)	1	1	1	1	3FFFFFFh
4M Partial	N/A	1	1	0	1	37FFFFFFh
8M Partial	8M Partial	1	0	1	1	2FFFFFFh
N/A	16M Partial	1	0	0	1	27FFFFFFh

Absolute Maximum Ratings

Item	Symbol	Value	Unit
Voltage of V_{DD} Supply Relative to V_{SS}	V_{DD}	-0.5 to +3.6	V
Voltage at Any Pin Relative to V_{SS}	V_{IN} , V_{OUT}	-0.5 to +3.6	V
Short Circuit Output Current	I_{OUT}	± 50	mA
Storage temperature	T_{STG}	-55 to +125	$^{\circ}C$

WARNING: Semiconductor devices can be permanently damaged by application of stress (voltage, current, temperature, etc.) in excess of absolute maximum ratings. Do not exceed these ratings.

Recommended Operating Conditions (See Warning Below)

Parameter	Symbol	Min	Max	Unit
Supply Voltage	V_{DD}	2.7	3.1	V
	V_{SS}	0	0	V
High Level Input Voltage (Note 1)	V_{IH}	$V_{DD} 0.8$	$V_{DD}+0.2$	V
High Level Input Voltage (Note 1)	V_{IL}	-0.3	$V_{DD} 0.2$	V
Ambient Temperature	T_A	-30	85	$^{\circ}C$

Notes:

1. Maximum DC voltage on input and I/O pins is $V_{DD}+0.2V$. During voltage transitions, inputs can positive overshoot to $V_{DD}+1.0V$ for periods of up to 5 ns.
2. Minimum DC voltage on input or I/O pins is -0.3V. During voltage transitions, inputs can negative overshoot V_{SS} to -1.0V for periods of up to 5ns.

WARNING: Recommended operating conditions are normal operating ranges for the semiconductor device. All the device's electrical characteristics are warranted when operated within these ranges.

Always use semiconductor devices within the recommended operating conditions. Operation outside these ranges can adversely affect reliability and could result in device failure.

No warranty is made with respect to uses, operating conditions, or combinations not represented on the data sheet. Users considering application outside the listed conditions are advised to contact their FUJITSU representative beforehand.

Package Capacitance

Test conditions: $T_A = 25^{\circ}C$, $f = 1.0$ MHz

Symbol	Description	Test Setup	Typ	Max	Unit
C_{IN1}	Address Input Capacitance	$V_{IN} = 0V$	—	5	pF
C_{IN2}	Control Input Capacitance	$V_{IN} = 0V$	—	5	pF
C_{IO}	Data Input/Output Capacitance	$V_{IO} = 0V$	—	8	pF

DC Characteristics (Under Recommended Conditions Unless Otherwise Noted)

Parameter	Symbol	Test Conditions	16M		32M		64M		Unit		
			Min.	Max.	Min.	Max.	Min.	Max.			
Input Leakage Current	I_{LI}	$V_{IN} = V_{SS}$ to V_{DD}	-1.0	+1.0	-1.0	+1.0	-1.0	+1.0	μA		
Output Leakage Current	I_{LO}	$V_{OUT} = V_{SS}$ to V_{DD} , Output Disable	-1.0	+1.0	-1.0	+1.0	-1.0	+1.0	μA		
Output High Voltage Level	V_{OH}	$V_{DD} = V_{DD}(\text{min})$, $I_{OH} = -0.5\text{mA}$	2.2	—	2.4	—	2.4	—	V		
Output Low Voltage Level	V_{OL}	$I_{OL} = 1\text{mA}$	—	0.4	—	0.4	—	0.4	V		
V_{DD} Power Down Current	I_{DDPS}	$V_{DD} = V_{DD} \text{ max.},$ $V_{IN} = V_{IH}$ or $V_{IL},$ $CE1 \leq 0.2 \text{ V}$	SLEEP			10	—	10	—	10	μA
	I_{DDP4}		4M Partial		N/A		—	40	N/A		μA
	I_{DDP8}		8M Partial		N/A		—	50	—	80	μA
	I_{DDP16}		16M Partial		N/A		N/A		—	100	μA
V_{DD} Standby Current	I_{DDS}	$V_{DD} = V_{DD} \text{ max.},$ $V_{IN} = V_{IH}$ or V_{IL} $CE1 = CE2 = V_{IH}$	—	1	—	1.5	—	1.5		mA	
	I_{DDS1}	$V_{DD} = V_{DD} \text{ max.},$ $V_{IN} \leq 0.2\text{V}$ or $V_{IN} \geq V_{DD} - 0.2\text{V},$ $CE1 = CE2 \geq V_{DD} - 0.2\text{V}$	TA < +85°C		—	100	—	80	—	170	μA
			TA < +40°C		—		—		—	90	μA
V_{DD} Active Current	I_{DDA1}	$V_{DD} = V_{DD} \text{ max.},$ $V_{IN} = V_{IH}$ or $V_{IL},$ $CE1 = V_{IL}$ and $CE2 = V_{IH},$ $I_{OUT} = 0\text{mA}$	$t_{RC} / t_{WC} = \text{min.}$		—	20	—	30	—	40	mA
	I_{DDA2}		$t_{RC} / t_{WC} = 1\mu s$		—	3	—	3	—	5	mA
V_{DD} Page Read Current	I_{DDA3}	$V_{DD} = V_{DD} \text{ max.}, V_{IN} = V_{IH}$ or $V_{IL},$ $CE1 = V_{IL}$ and $CE2 = V_{IH},$ $I_{OUT} = 0\text{mA}, t_{PRC} = \text{min.}$	N/A		—	10	—	10		mA	

Notes:

1. All voltages are referenced to V_{SS} .
2. DC Characteristics are measured after following POWER-UP timing.
3. I_{OUT} depends on the output load conditions.

AC Characteristics (Under Recommended Operating Conditions Unless Otherwise Noted)

Read Operation

Parameter	Symbol	16M		32M		64M		Unit	Notes
		Min.	Max.	Min.	Max.	Min.	Max.		
Read Cycle Time	t_{RC}	70	1000	65	1000	65	1000	ns	1, 2
CE1# Access Time	t_{CE}	—	60	—	65	—	65	ns	3
OE# Access Time	t_{OE}	—	40	—	40	—	40	ns	3
Address Access Time	t_{AA}	—	60	—	65	—	65	ns	3, 5
LB# / UB# Access Time	t_{BA}	—	30	—	30	—	30	ns	3
Page Address Access Time	t_{PAA}	N/A		—	20	—	20	ns	3,6
Page Read Cycle Time	t_{PRC}	N/A		20	1000	20	1000	ns	1, 6, 7
Output Data Hold Time	t_{OH}	5	—	5	—	5	—	ns	3
CE1# Low to Output Low-Z	t_{CLZ}	5	—	5	—	5	—	ns	4
OE# Low to Output Low-Z	t_{OLZ}	0	—	0	—	0	—	ns	4
LB# / UB# Low to Output Low-Z	t_{BLZ}	0	—	0	—	0	—	ns	4
CE1# High to Output High-Z	t_{CHZ}	—	20	—	20	—	20	ns	3
OE# High to Output High-Z	t_{OHZ}	—	20	—	14	—	14	ns	3
LB# / UB# High to Output High-Z	t_{BHZ}	—	20	—	20	—	20	ns	3
Address Setup Time to CE1# Low	t_{ASC}	-6	—	-6	—	-6	—	ns	
Address Setup Time to OE# Low	t_{ASO}	10	—	10	—	10	—	ns	
Address Invalid Time	t_{AX}	—	10	—	10	—	10	ns	5, 8
Address Hold Time from CE1# High	t_{CHAH}	-6	—	-6	—	-6	—	ns	9
Address Hold Time from OE# High	t_{OHAH}	-6	—	-6	—	-6	—	ns	
WE# High to OE# Low Time for Read	t_{WHOL}	10	1000	12	—	25	—	ns	10
CE1# High Pulse Width	t_{CP}	10	—	12	—	12	—	ns	

Notes:

1. Maximum value is applicable if CE1# is kept at Low without change of address input of A3 to A21. If needed by system operation, please contact local Spansion representative for the relaxation of 1 μ s limitation.
2. Address should not be changed within minimum t_{RC} .
3. The output load 50 pF with 50 ohm termination to $V_{DD} \times 0.5$ (16M), The output load 50 pF (32M and 64M).
4. The output load 5pF.
5. Applicable to A3 to A21 (32M and 64M) when CE1# is kept at Low.
6. Applicable only to A0, A1 and A2 (32M and 64M) when CE1# is kept at Low for the page address access.
7. In case Page Read Cycle is continued with keeping CE1# stays Low, CE1# must be brought to High within 4 μ s. In other words, Page Read Cycle must be closed within 4 μ s.
8. Applicable when at least two of address inputs among applicable are switched from previous state.
9. $t_{RC}(\text{min})$ and $t_{PRC}(\text{min})$ must be satisfied.
10. If actual value of t_{WHOL} is shorter than specified minimum values, the actual t_{AA} of following Read can become longer by the amount of subtracting the actual value from the specified minimum value.

AC Characteristics

Write Operation

Parameter	Symbol	16M		32M		64M		Unit	Notes
		Min.	Max.	Min.	Max.	Min.	Max.		
Write Cycle Time	t_{WC}	70	1000	65	1000	65	1000	ns	1,2
Address Setup Time	t_{AS}	0	—	0	—	0	—	ns	3
CE1# Write Pulse Width	t_{CW}	45	—	40	—	40	—	ns	3
WE# Write Pulse Width	t_{WP}	45	—	40	—	40	—	ns	3
LB#/UB# Write Pulse Width	t_{BW}	45	—	40	—	40	—	ns	3
LB#/UB# Byte Mask Setup Time	t_{BS}	-5	—	-5	—	-5	—	ns	4
LB#/UB# Byte Mask Hold Time	t_{BH}	-5	—	-5	—	-5	—	ns	5
Write Recovery Time	t_{WR}	0	—	0	—	0	—	ns	6
CE1# High Pulse Width	t_{CP}	10	—	12	—	12	—	ns	
WE# High Pulse Width	t_{WHP}	7.5	1000	7.5	1000	7.5	1000	ns	7
LB#/UB# High Pulse Width	t_{BHP}	10	1000	12	1000	12	1000	ns	
Data Setup Time	t_{DS}	15	—	12	—	12	—	ns	
Data Hold Time	t_{DH}	0	—	0	—	0	—	ns	
OE# High to CE1# Low Setup Time for Write	t_{OHCL}	-5	—	-5	—	-5	—	ns	8
OE# High to Address Setup Time for Write	t_{OES}	0	—	0	—	0	—	ns	9
LB# and UB# Write Pulse Overlap	t_{BWO}	30	—	30	—	30	—	ns	

Notes:

1. Maximum value is applicable if CE1# is kept at Low without any address change. If the relaxation is needed by system operation, please contact local Spansion representative for the relaxation of 1 μ s limitation.
2. Minimum value must be equal or greater than the sum of write pulse (t_{CW} , t_{WP} or t_{BW}) and write recovery time (t_{WR}).
3. Write pulse is defined from High to Low transition of CE1#, WE#, or LB#/UB#, whichever occurs last.
4. Applicable for byte mask only. Byte mask setup time is defined to the High to Low transition of CE1# or WE# whichever occurs last.
5. Applicable for byte mask only. Byte mask hold time is defined from the Low to High transition of CE1# or WE# whichever occurs first.
6. Write recovery is defined from Low to High transition of CE1#, WE#, or LB#/UB#, whichever occurs first.
7. t_{WPH} minimum is absolute minimum value for device to detect High level. And it is defined at minimum V_{IH} level.
8. If OE# is Low after minimum t_{OHCL} , read cycle is initiated. In other words, OE# must be brought to High within 5ns after CE1# is brought to Low. Once read cycle is initiated, new write pulse should be input after minimum t_{RC} is met.
9. If OE# is Low after new address input, read cycle is initiated. In other word, OE# must be brought to High at the same time or before new address valid. Once read cycle is initiated, new write pulse should be input after minimum t_{RC} is met and data bus is in High-Z.

AC Characteristics

Power Down Parameters

Parameter	Symbol	16M		32M		64M		Unit	Note
		Min.	Max.	Min.	Max.	Min.	Max.		
CE2 Low Setup Time for Power Down Entry	t_{CSP}	10	—	10	—	10	—	ns	
CE2 Low Hold Time after Power Down Entry	t_{C2LP}	80	—	65	—	65	—	ns	
CE1# High Hold Time following CE2 High after Power Down Exit [SLEEP mode only]	t_{CHH}	300	—	300	—	300	—	μs	1
CE1# High Hold Time following CE2 High after Power Down Exit [not in SLEEP mode]	t_{CHHP}	N/A		1	—	1	—	μs	2
CE1# High Setup Time following CE2 High after Power Down Exit	t_{CHS}	0	—	0	—	0	—	ns	1

Notes:

1. Applicable also to power-up.
2. Applicable when 4Mb and 8Mb Partial modes are programmed.

Other Timing Parameters

Parameter	Symbol	16M		32M		64M		Unit	Note
		Min.	Max.	Min.	Max.	Min.	Max.		
CE1# High to OE# Invalid Time for Standby Entry	t_{CHOX}	10	—	10	—	10	—	ns	
CE1# High to WE# Invalid Time for Standby Entry	t_{CHWX}	10	—	10	—	10	—	ns	1
CE2 Low Hold Time after Power-up	t_{C2LH}	50	—	50	—	50	—	μs	
CE1# High Hold Time following CE2 High after Power-up	t_{CHH}	300	—	300	—	300	—	μs	
Input Transition Time	t_T	1	25	1	25	1	25	ns	2

Notes:

1. Some data might be written into any address location if $t_{CHWX}(min)$ is not satisfied.
2. The Input Transition Time (t_T) at AC testing is 5ns as shown in below. If actual t_T is longer than 5ns, it can violate the AC specification of some of the timing parameters.

AC Characteristics

AC Test Conditions

Symbol	Description	Test Setup	Value	Unit	Note
V_{IH}	Input High Level		$V_{DD} * 0.8$	V	
V_{IL}	Input Low Level		$V_{DD} * 0.2$	V	
V_{REF}	Input Timing Measurement Level		$V_{DD} * 0.5$	V	
t_T	Input Transition Time	Between V_{IL} and V_{IH}	5	ns	

AC Measurement Output Load Circuits

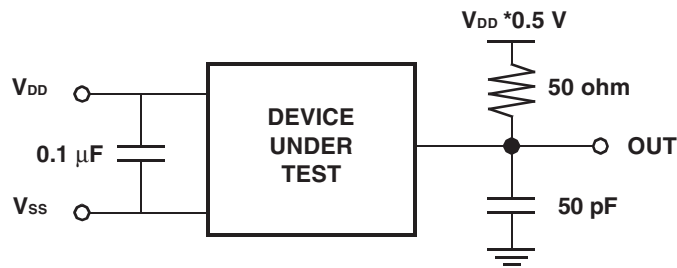

Figure 58. AC Output Load Circuit – 16 Mb

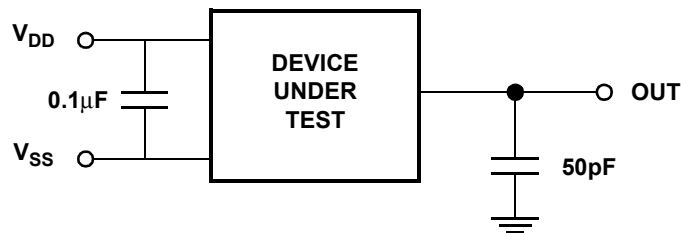
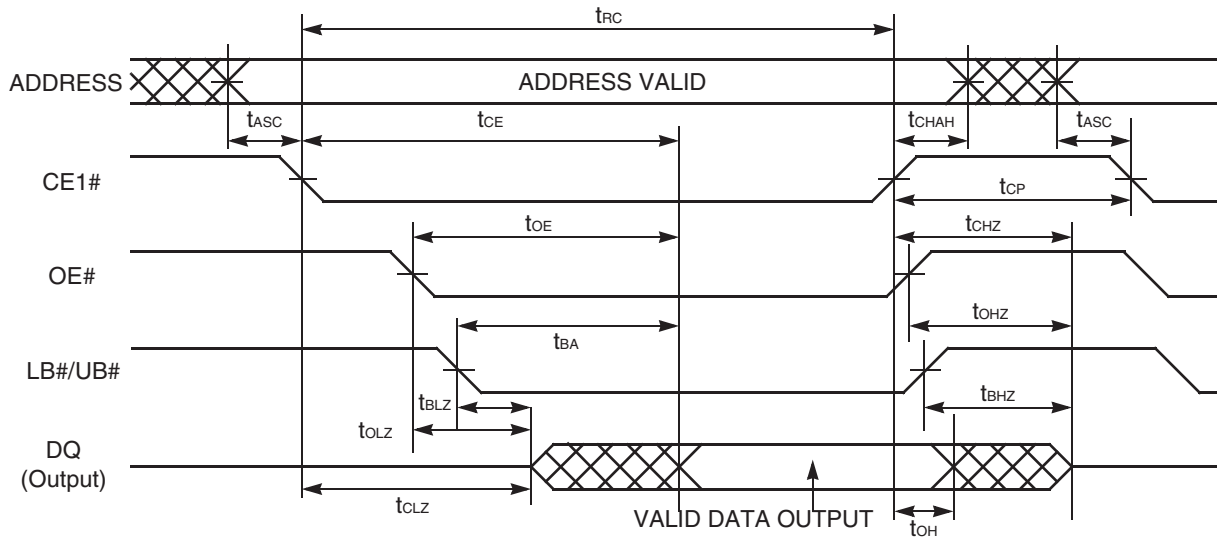

Figure 59. AC Output Load Circuit – 32 Mb and 64 Mb

Timing Diagrams

Read Timings



Note: This timing diagram assumes CE2=H and WE#=H.

Figure 60. Read Timing #1 (Basic Timing)

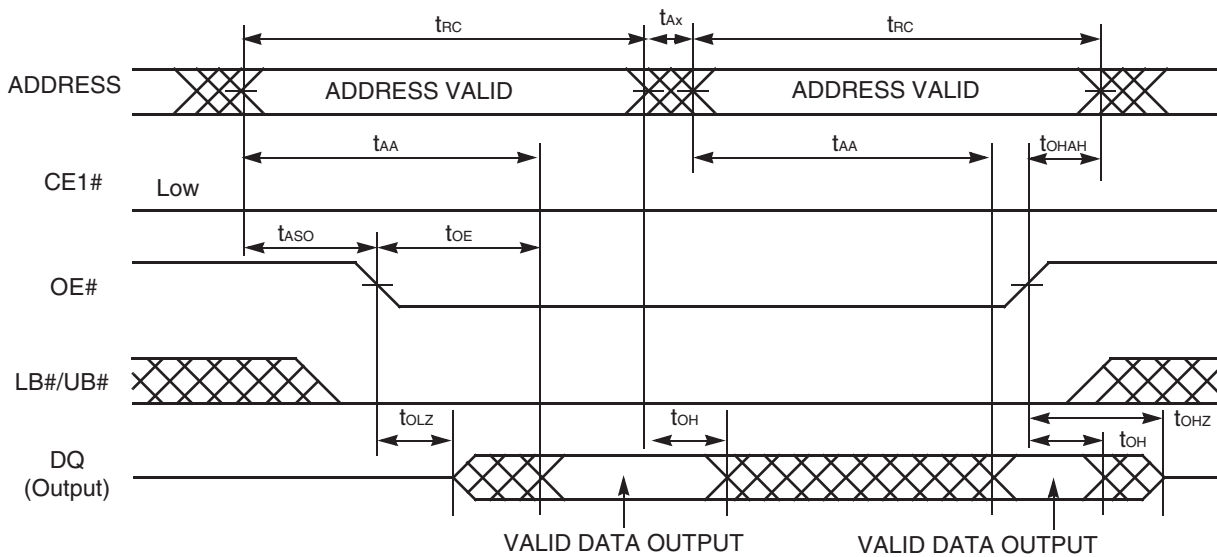

Note: This timing diagram assumes CE2=H and WE#=H.

Figure 61. Read Timing #2 (OE# Address Access)

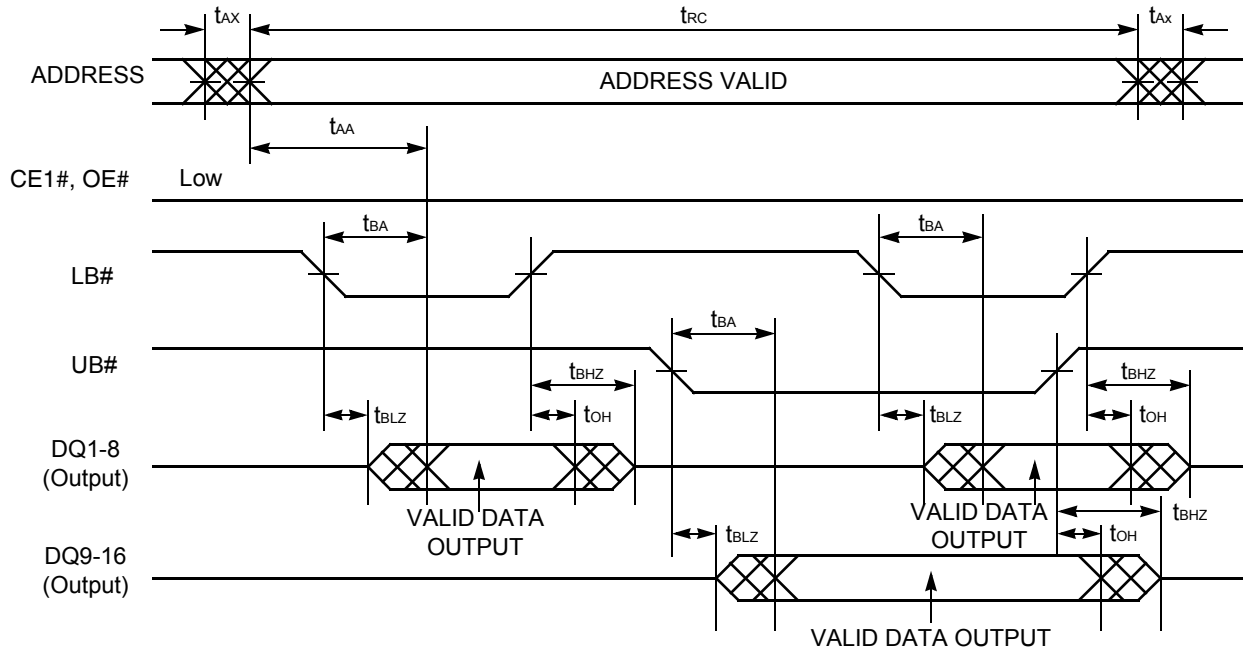

Note: This timing diagram assumes $CE2=H$ and $WE#=H$.

Figure 62. Read Timing #3 (LB#/UB# Byte Access)

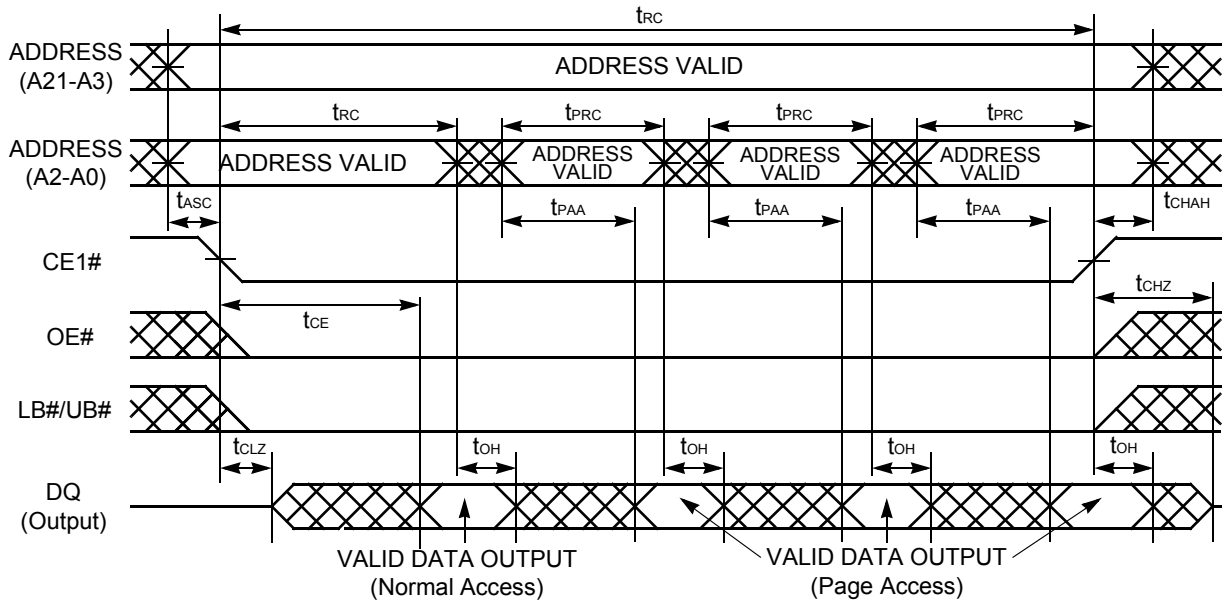

Note: This timing diagram assumes $CE2=H$ and $WE#=H$.

Figure 63. Read Timing #4 (Page Address Access after CEI# Control Access for 32M and 64M Only)

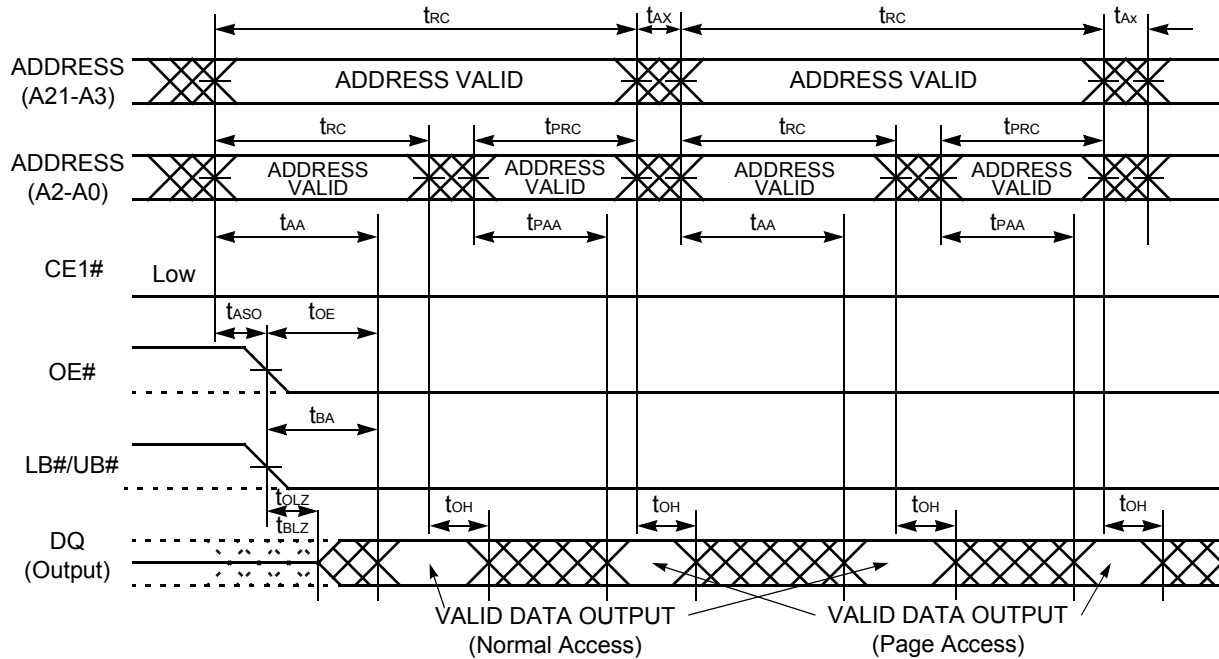

Notes:

1. This timing diagram assumes CE2=H and WE#=H.
2. Either or both LB# and UB# must be Low when both CE1# and OE# are Low.

Figure 64. Read Timing #5 (Random and Page Address Access for 32M and 64M Only)

Write Timings

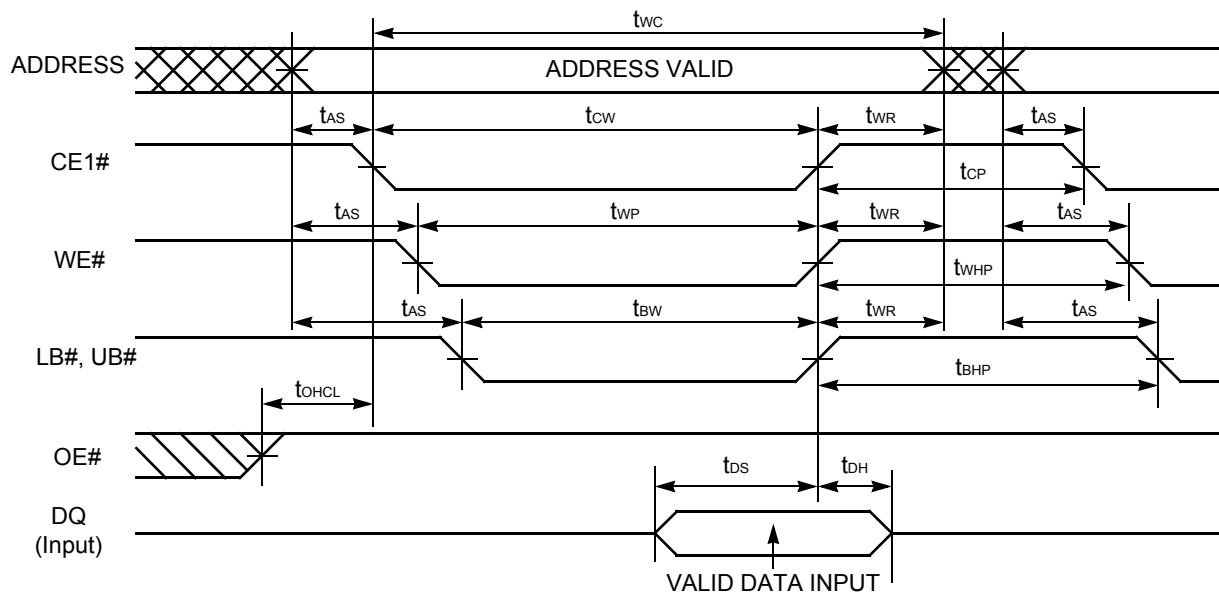

Note: This timing diagram assumes CE2=H.

Figure 65. Write Timing #1 (Basic Timing)

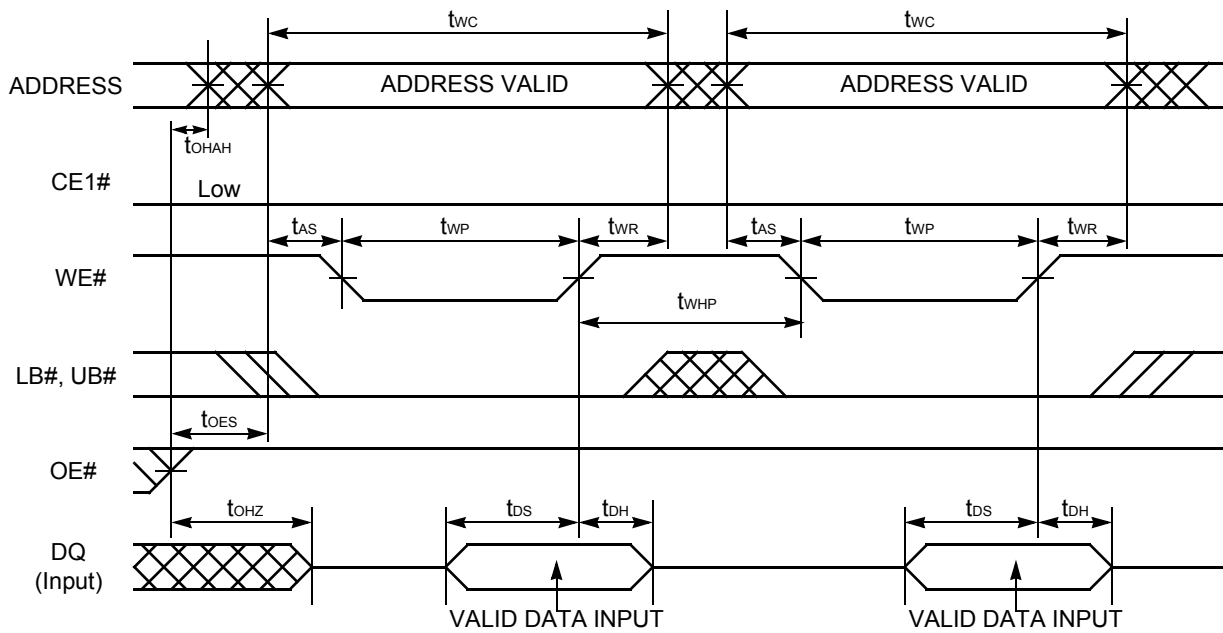

Note: This timing diagram assumes CE2=H.

Figure 66. Write Timing #2 (WE# Control)

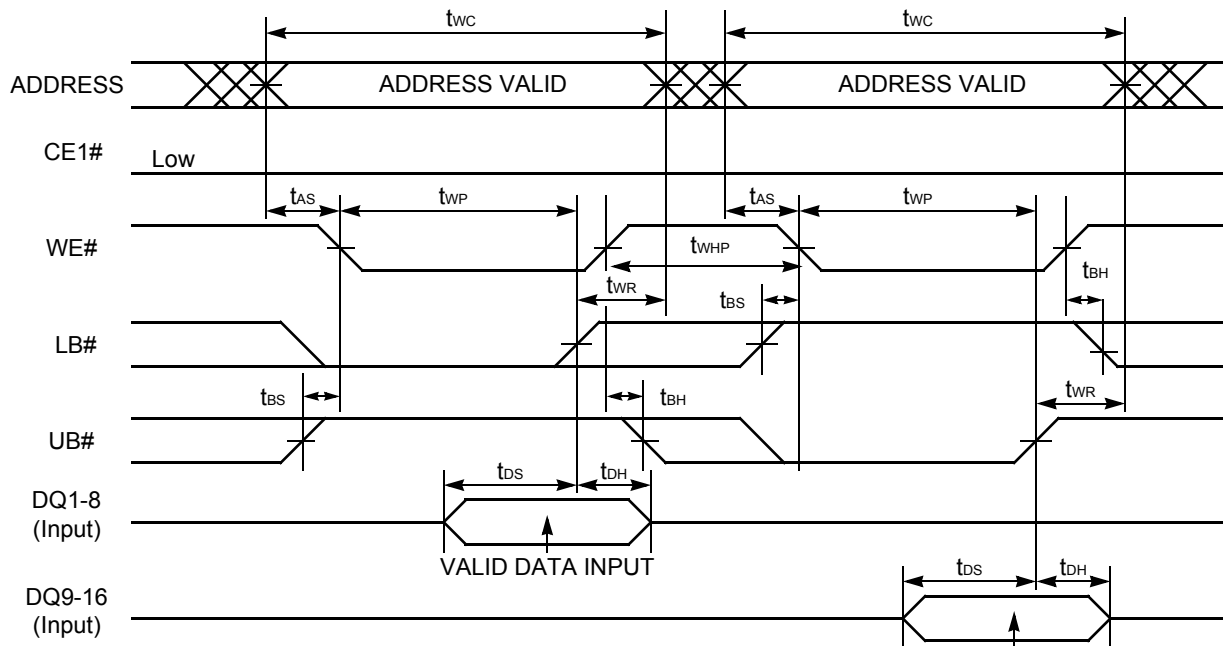

Note: This timing diagram assumes CE2=H and OE#=H.

Figure 67. Write Timing #3-1(WE#/LB#/UB# Byte Write Control)

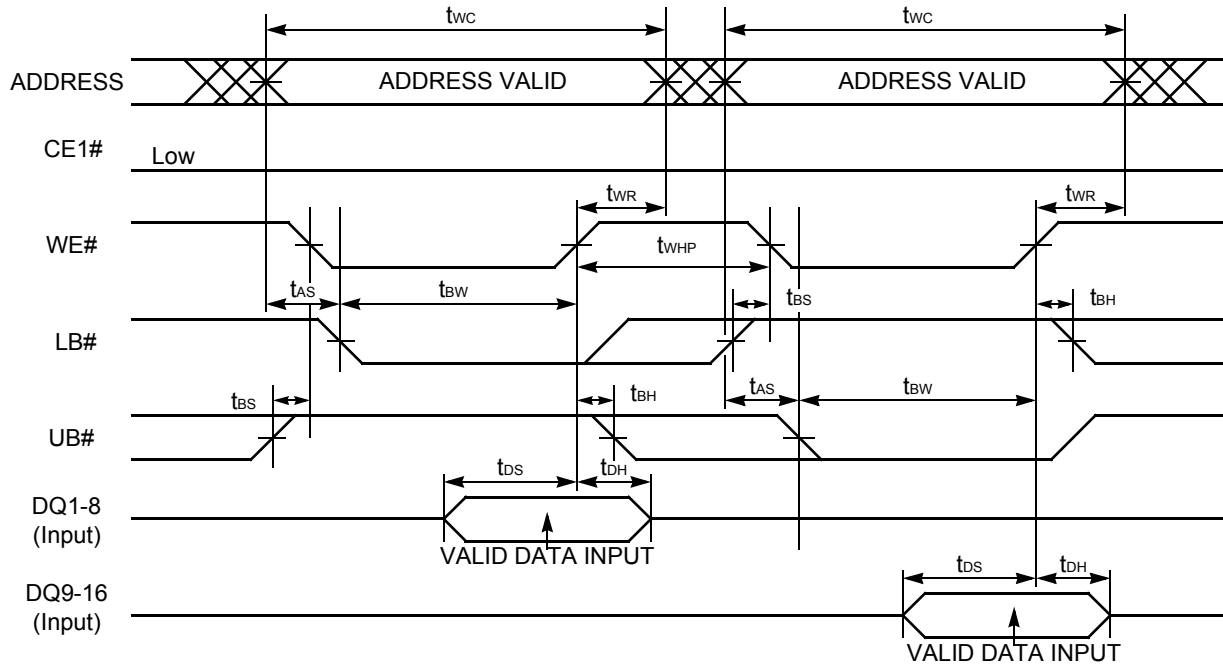

Note: This timing diagram assumes CE2=H and OE#=H.

Figure 68. Write Timing #3-3 (WE#/LB#/UB# Byte Write Control)

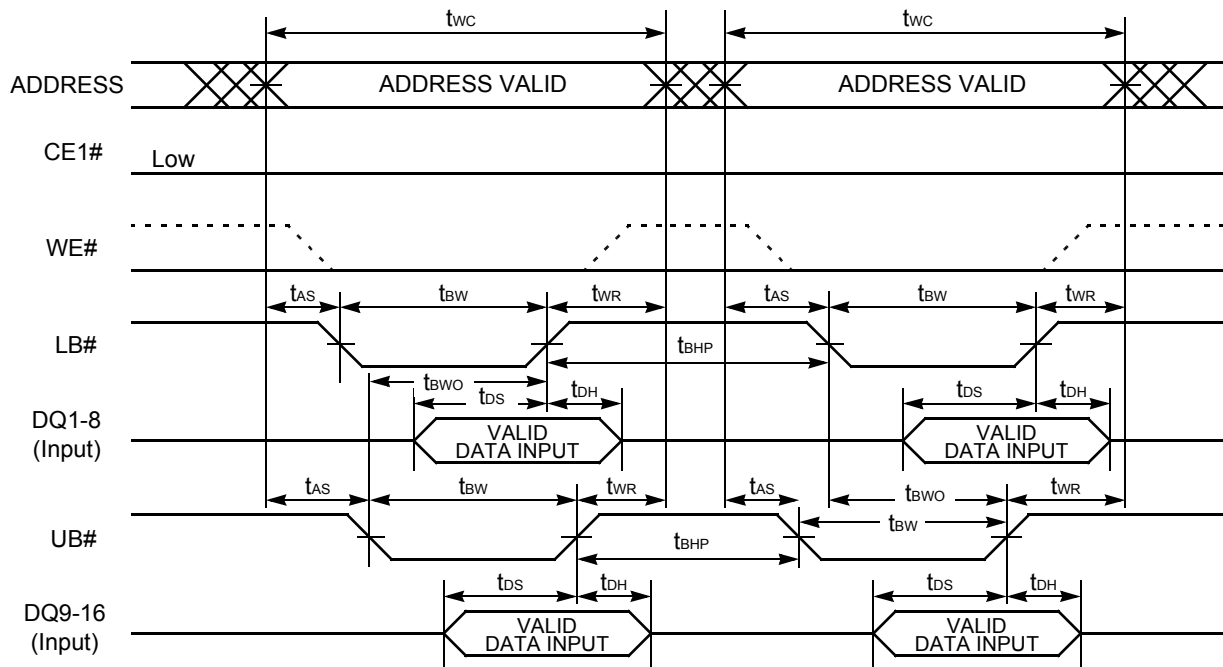

Note: This timing diagram assumes CE2=H and OE#=H.

Figure 69. Write Timing #3-4 (WE#/LB#/UB# Byte Write Control)

Read/Write Timings

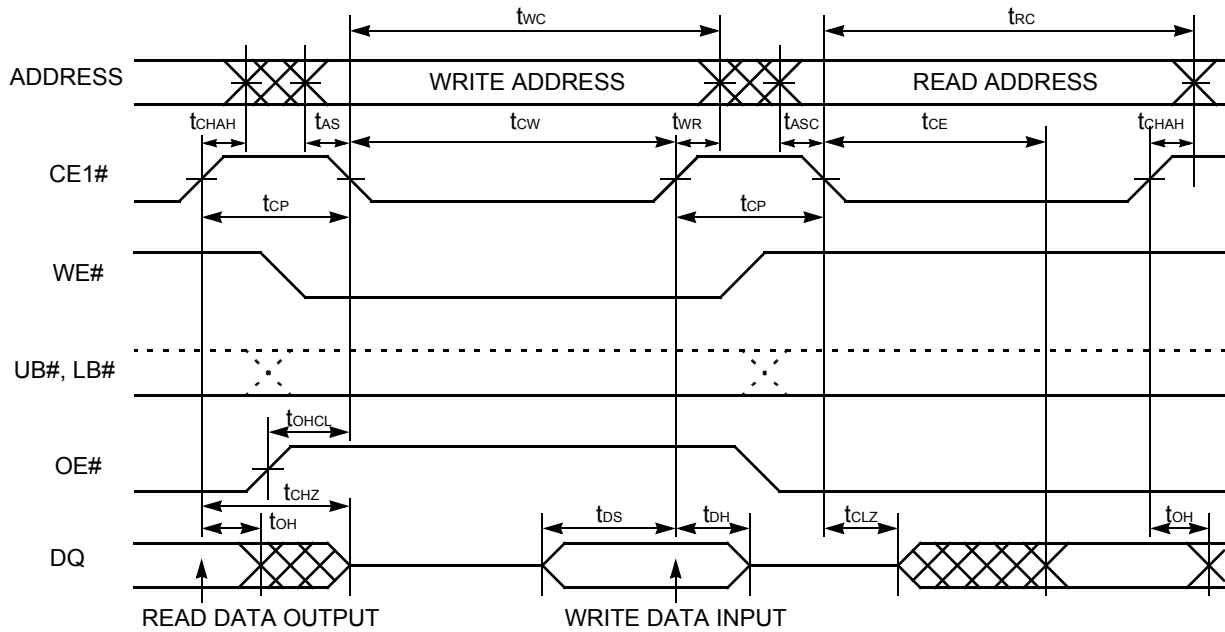

Notes:

1. This timing diagram assumes $CE2=H$.
2. Write address is valid from either $CE1\#$ or $WE\#$ of last falling edge.

Figure 70. Read/Write Timing #I-1 (CE1# Control)

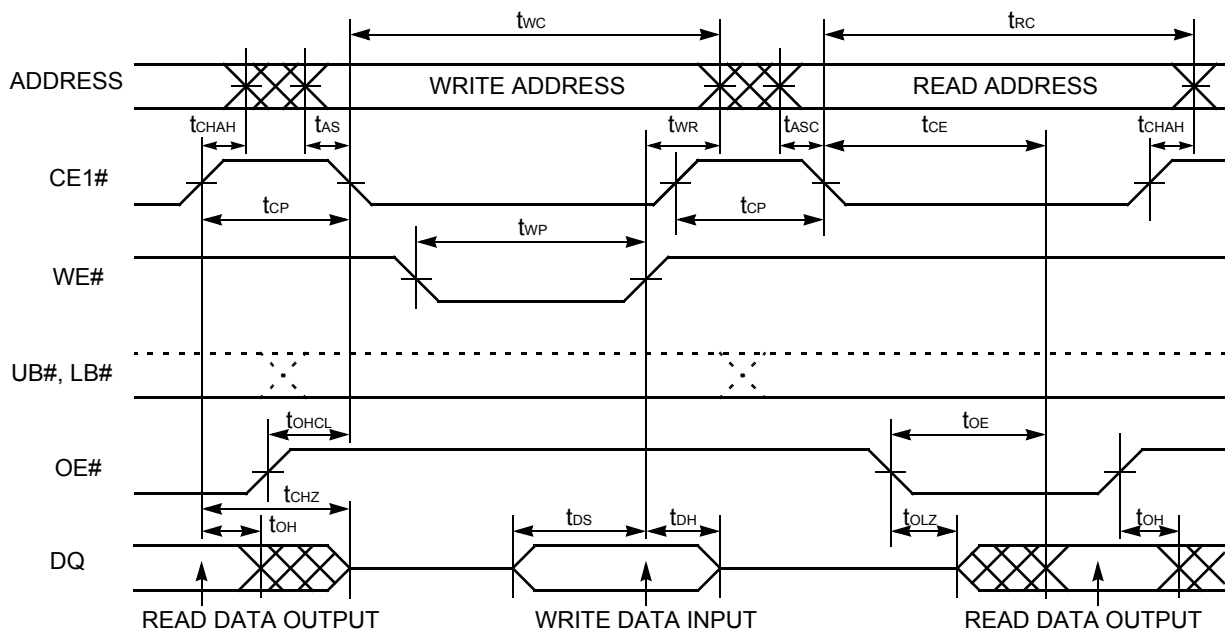

Notes:

1. This timing diagram assumes $CE2=H$.
2. $OE\#$ can be fixed Low during write operation if it is $CE1\#$ controlled write at Read-Write-Read sequence.

Figure 71. Read / Write Timing #I-2 (CE1#/WE#/OE# Control)

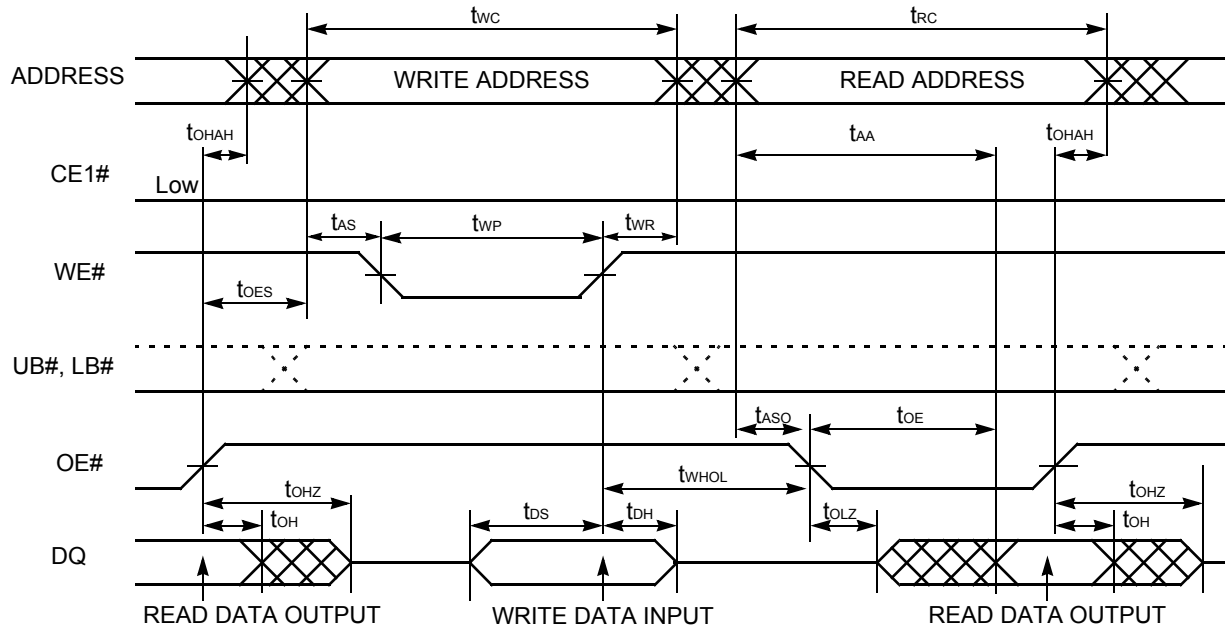

Notes:

1. This timing diagram assumes CE2=H.
2. CE1# can be tied to Low for WE# and OE# controlled operation.

Figure 72. Read / Write Timing #2 (OE#, WE# Control)

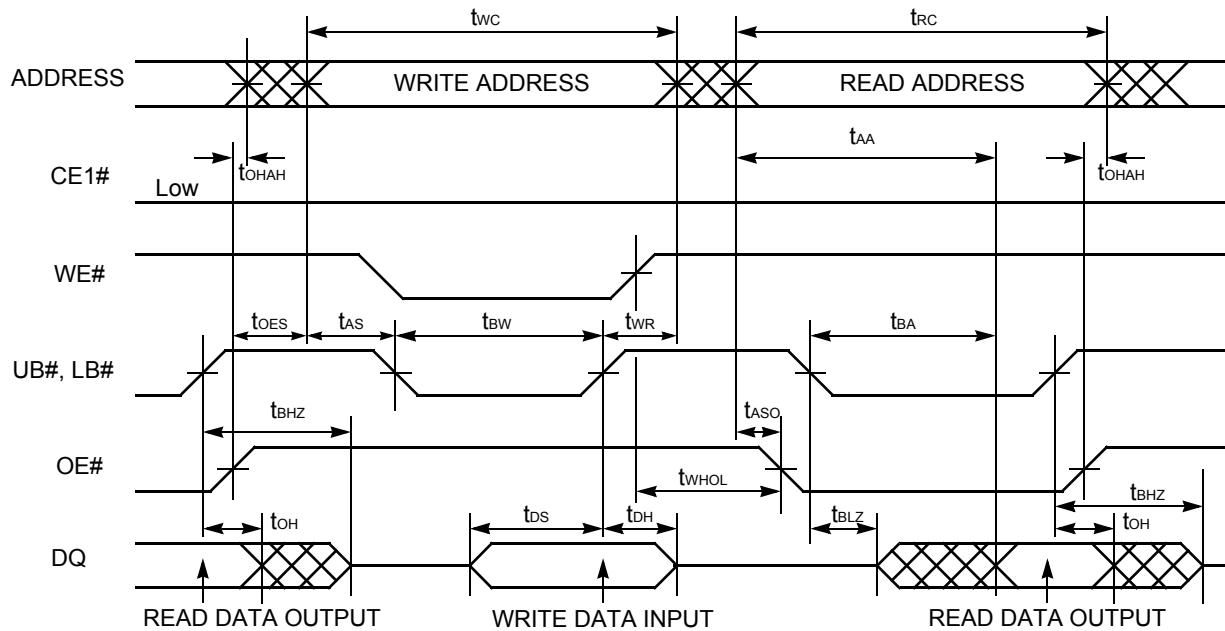

Notes:

1. This timing diagram assumes CE2=H.
2. CE1# can be tied to Low for WE# and OE# controlled operation.

Figure 73. Read / Write Timing #3 (OE#, WE#, LB#, UB# Control)

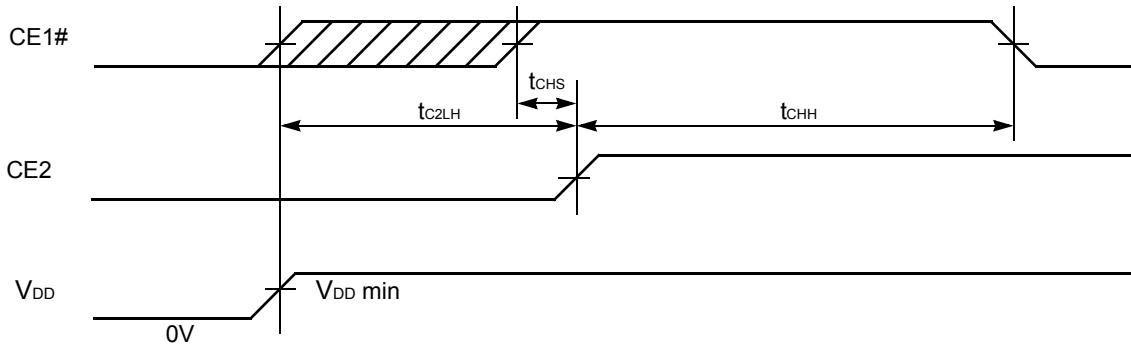

Note: The t_{C2LH} specifies after V_{DD} reaches specified minimum level.

Figure 74. Power-up Timing #1

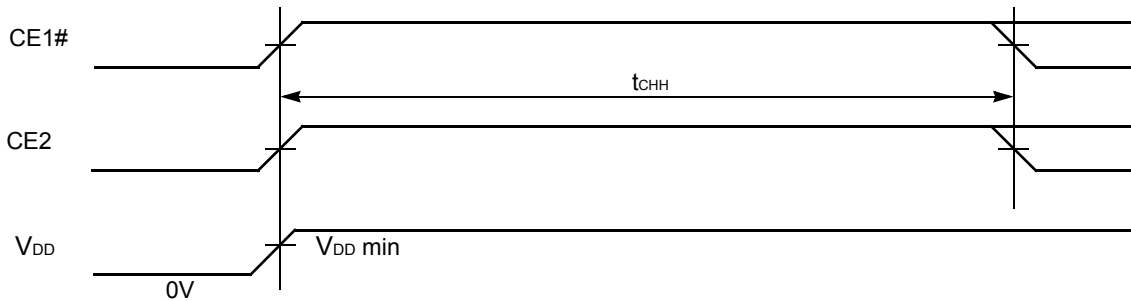

Note: The t_{CHH} specifies after V_{DD} reaches specified minimum level and applicable to both CE1# and CE2.

Figure 75. Power-up Timing #2

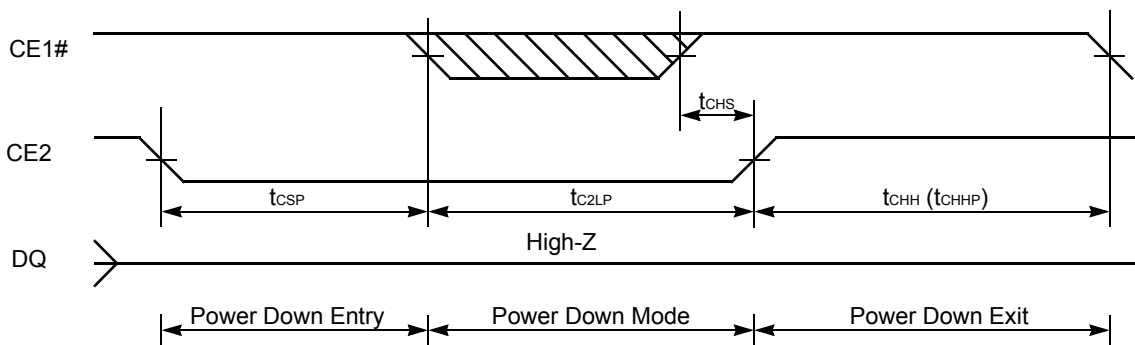

Note: This Power Down mode can be also used as a reset timing if POWER-UP timing above could not be satisfied and Power-Down program was not performed prior to this reset.

Figure 76. Power Down Entry and Exit Timing

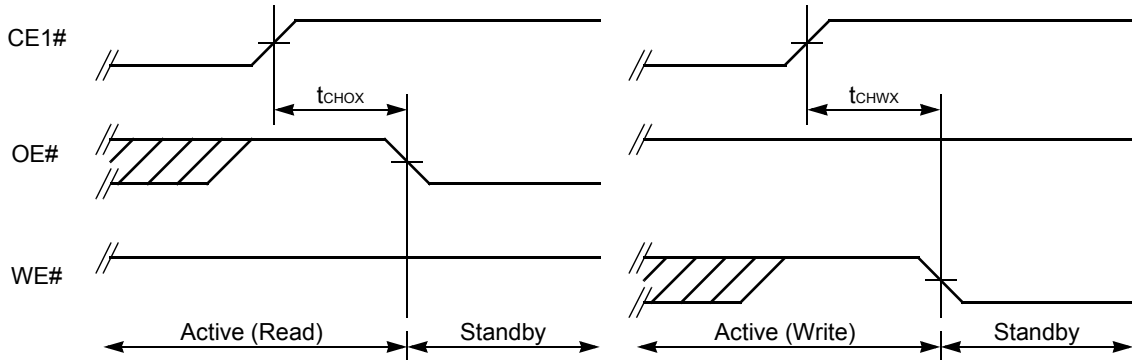

Note: Both t_{CHOX} and t_{CHWX} define the earliest entry timing for Standby mode. If either of timing is not satisfied, it takes t_{RC} (min) period for Standby mode from CE1# Low to High transition.

Figure 77. Standby Entry Timing after Read or Write

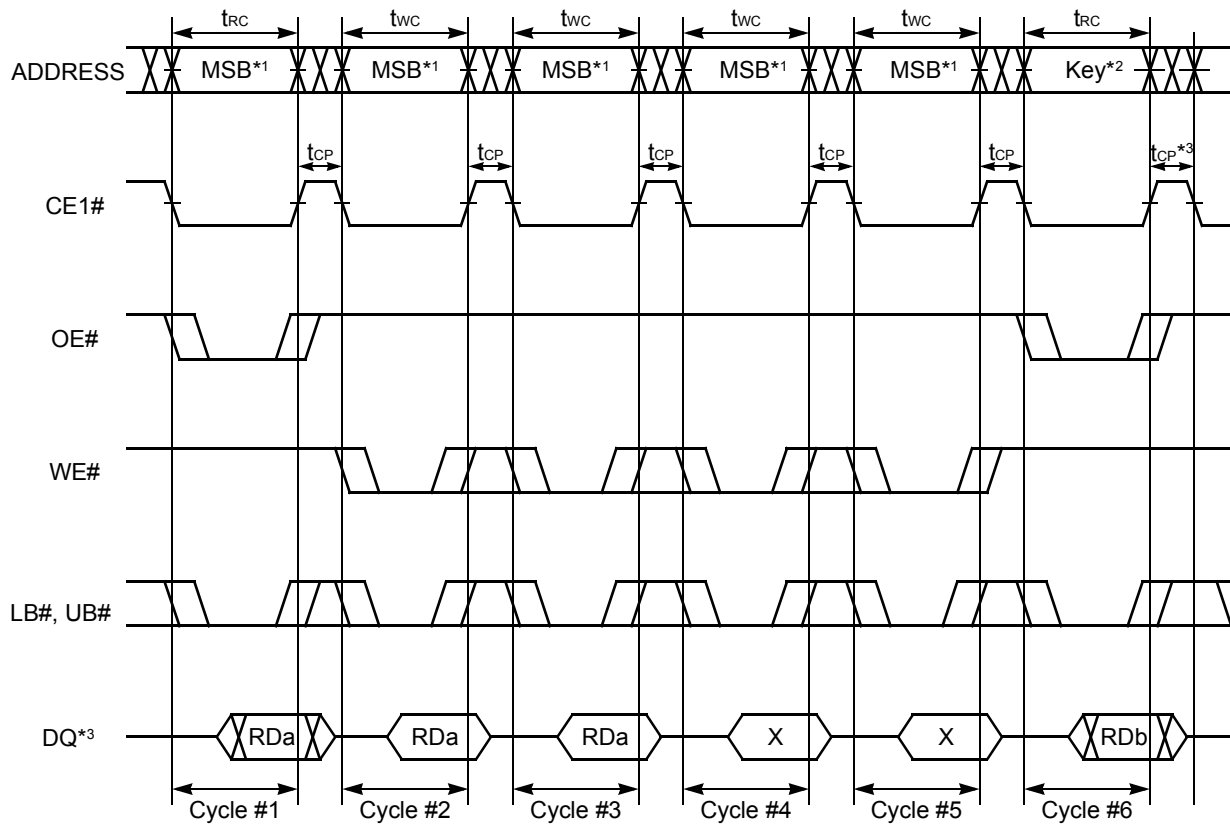

Notes:

1. The all address inputs must be High from Cycle #1 to #5.
2. The address key must confirm the format specified in page 136. If not, the operation and data are not guaranteed.
3. After t_{CP} following Cycle #6, the Power Down Program is completed and returned to the normal operation.

Figure 78. Power Down Program Timing (for 32M/64M Only)

SRAM

4/8 Megabit CMOS SRAM

Common Features

- Process Technology: Full CMOS
- Power Supply Voltage: 2.7~3.3V
- Three state outputs

Version	Density	Organization (ISBI, Max.)	Standby (ICC2, Max.)	Operating	Mode
F	4Mb	x8 or x16 (note 1)	10 μ A	22 mA	Dual CS, UB# / LB# (tCS)
G	4Mb	x8 or x16 (note 1)	10 μ A	22 mA	Dual CS, UB# / LB# (tCS)
C	8Mb	x8 or x16 (note 1)	15 μ A	22 mA	Dual CS, UB# / LB# (tCS)
D	8Mb	X16	TBD	TBD	Dual CS, UB# / LB# (tCS)

Notes:

1. UB#, LB# swapping is available only at x16. x8 or x16 select by BYTE# pin.

Pin Description

Pin Name	Description	I/O
CS1#, CS2	Chip Selects	I
OE#	Output Enable	I
WE#	Write Enable	I
BYTE#	Word (V _{CC})/Byte (V _{SS}) Select	I
A0~A17 (4M) A0~A18 (8M)	Address Inputs	I
SA	Address Input for Byte Mode	I
I/O0~I/O15	Data Inputs/Outputs	I/O
V _{CC}	Power Supply	-
V _{SS}	Ground	-
DNU	Do Not Use	-
NC	No Connection	-

Functional Description

4M Version F, 4M version G, 8M version C

CSI#	CS2	OE#	WE#	BYTE#	SA	LB#	UB#	IO _{0~7}	IO _{8~15}	Mode	Power
H	X	X	X	X	X	X	X	High-Z	High-Z	Deselected	Standby
X	L	X	X	X	X	X	X	High-Z	High-Z	Deselected	Standby
X	X	X	X	X	X	H	H	High-Z	High-Z	Deselected	Standby
L	H	H	H	V _{CC}	X	L	X	High-Z	High-Z	Output Disabled	Active
L	H	H	H	V _{CC}	X	X	L	High-Z	High-Z	Output Disabled	Active
L	H	L	H	V _{CC}	X	L	H	D _{out}	High-Z	Lower Byte Read	Active
L	H	L	H	V _{CC}	X	H	L	High-Z	D _{out}	Upper Byte Read	Active
L	H	L	H	V _{CC}	X	L	L	D _{out}	D _{out}	Word Read	Active
L	H	X	L	V _{CC}	X	L	H	D _{in}	High-Z	Lower Byte Write	Active
L	H	X	L	V _{CC}	X	H	L	High-Z	D _{in}	Upper Byte Write	Active
L	H	X	L	V _{CC}	X	L	L	D _{in}	D _{in}	Word Write	Active

Note: X means don't care (must be low or high state).

Byte Mode

CSI#	CS2	OE#	WE#	BYTE#	SA	LB#	UB#	IO _{0~7}	IO _{8~15}	Mode	Power
H	X	X	X	X	X	X	X	High-Z	High-Z	Deselected	Standby
X	L	X	X	X	X	X	X	High-Z	High-Z	Deselected	Standby
L	H	H	H	X	X	H	H	High-Z	High-Z	Deselected	Standby
L	H	L	L	V _{CC}	X	L	X	High-Z	High-Z	Output Disabled	Active
L	H	X	L	V _{CC}	X	X	L	High-Z	High-Z	Output Disabled	Active

Functional Description

8M Version D

CS1#	CS2	OE#	WE#	LB#	UB#	IO ₀₋₈	IO ₉₋₁₆	Mode	Power
H	X	X	X	X	X	High-Z	High-Z	Deselected	Standby
X	L	X	X	X	X	High-Z	High-Z	Deselected	Standby
X	X	X	X	H	H	High-Z	High-Z	Deselected	Standby
L	H	H	H	L	X	High-Z	High-Z	Output Disabled	Active
L	H	H	H	X	L	High-Z	High-Z	Output Disabled	Active
L	H	L	H	L	H	D _{out}	High-Z	Lower Byte Read	Active
L	H	L	H	H	L	High-Z	D _{out}	Upper Byte Read	Active
L	H	L	H	L	L	D _{out}	D _{out}	Word Read	Active
L	H	X	L	L	H	D _{in}	High-Z	Lower Byte Write	Active
L	H	X	L	H	L	High-Z	D _{in}	Upper Byte Write	Active
L	H	X	L	L	L	D _{in}	D _{in}	Word Write	Active

Note: X means don't care (must be low or high state).

Absolute Maximum Ratings (4M Version F)

Item	Symbol	Ratings	Unit
Voltage on any pin relative to V _{SS}	V _{IN} , V _{OUT}	-0.2 to V _{CC} +0.3V	V
Voltage on V _{CC} supply relative to V _{SS}	V _{CC}	-0.2 to 4.0V	V
Power Dissipation	P _D	1.0	W
Operating Temperature	T _A	-40 to 85	°C

Stresses greater than those listed under “Absolute Maximum Ratings” may cause permanent damage to the device. Functional operation should be restricted to recommended operating condition. Exposure to absolute maximum rating conditions for extended periods may affect reliability.

Absolute Maximum Ratings (4M Version G, 8M Version C, 8M Version D)

Item	Symbol	Ratings	Unit
Voltage on any pin relative to V _{SS}	V _{IN} , V _{OUT}	-0.2 to V _{CC} +0.3V (Max. 3.6V)	V
Voltage on V _{CC} supply relative to V _{SS}	V _{CC}	-0.2 to 3.6V	V
Power Dissipation	P _D	1.0	W
Operating Temperature	T _A	-40 to 85	°C

Stresses greater than those listed under “Absolute Maximum Ratings” may cause permanent damage to the device. Functional operation should be restricted to recommended operating condition. Exposure to absolute maximum rating conditions for extended periods may affect reliability.

DC Characteristics

Recommended DC Operating Conditions (Note 1)

Item	Symbol	Min	Typ	Max	Unit
Supply voltage	V_{CC}	2.7	3.0	3.3	V
Ground	V_{SS}	0	0	0	V
Input high voltage	V_{IH}	2.2	-	$V_{CC}+0.2$ (Note 2)	V
Input low voltage	V_{IL}	-0.2 (Note 3)	-	0.6	V

Notes:

- $T_A = -40$ to 85°C , unless otherwise specified.
- Overshoot: $V_{CC}+1.0\text{V}$ in case of pulse width $\leq 20\text{ns}$.
- Undershoot: -1.0V in case of pulse width $\leq 20\text{ns}$.
- Overshoot and undershoot are sampled, not 100% tested.

Capacitance (f=1MHz, $T_A=25^\circ\text{C}$)

Item	Symbol	Test Condition	Min	Max	Unit
Input capacitance	C_{IN}	$V_{IN}=0\text{V}$	-	8	pF
Input/Output capacitance	C_{IO}	$V_{IO}=0\text{V}$	-	10	pF

Note: Capacitance is sampled, not 100% tested

DC Operating Characteristics Common

Item	Symbol	Test Conditions	Min	Typ (Note)	Max	Unit
Input leakage current	I_{LI}	$V_{IN}=V_{SS}$ to V_{CC}	-1	-	1	μA
Output leakage current	I_{LO}	$CS1\#=V_{IH}$ or $CS2=V_{IL}$ or $OE\#=V_{IH}$ or $WE\#=V_{IL}$ or $LB\#=UB\#=V_{IH}$, $V_{IO}=V_{SS}$ to V_{CC}	-1	-	1	μA
Output low voltage	V_{OL}	$I_{OL} = 2.1\text{mA}$	-	-	0.4	V
Output high voltage	V_{OH}	$I_{OH} = -1.0\text{mA}$	2.4	-	-	V

DC Operating Characteristics
4M Version F

Item	Symbol	Test Conditions	Min	Typ (Note)	Max	Unit
Average operating current	I _{CC1}	Cycle time=1μs, 100% duty, I _{IO} =0mA, CS1# ≤ 0.2V, CS2 ≥ V _{CC} -0.2V, BYTE#=V _{SS} or V _{CC} , V _{IN} ≤ 0.2V or V _{IN} ≥ V _{CC} -0.2V, LB# ≤ 0.2V or/and UB# ≤ 0.2V	-	-	3	mA
	I _{CC2}	Cycle time=Min, I _{IO} =0mA, 100% duty, CS1# = V _{IL} , CS2=V _{IH} , BYTE# = V _{SS} or V _{CC} , V _{IN} =V _{IL} or V _{IH} , LB# ≤ 0.2V or/and UB# ≤ 0.2V	-	-	22	mA
Standby Current (CMOS)	I _{SB1} (Note)	CS1# ≥ V _{CC} -0.2V, CS2 ≥ V _{CC} -0.2V (CS1# controlled) or CS2 ≤ 0.2V (CS2 controlled), BYTE# = V _{SS} or V _{CC} , Other input = 0~V _{CC}	-	1.0 (Note)	10	μA

Note: Typical values are not 100% tested.

DC Operating Characteristics
4M Version G

Item	Symbol	Test Conditions	Min	Typ (Note)	Max	Unit
Average operating current	I _{CC1}	Cycle time=1μs, 100% duty, I _{IO} =0mA, CS1# ≤ 0.2V, CS2 ≥ V _{CC} -0.2V, BYTE#=V _{SS} or V _{CC} , V _{IN} ≤ 0.2V or V _{IN} ≥ V _{CC} -0.2V, LB# ≤ 0.2V or/and UB# ≤ 0.2V	-	-	4	mA
	I _{CC2}	Cycle time=Min, I _{IO} =0mA, 100% duty, CS1# = V _{IL} , CS2=V _{IH} , BYTE# = V _{SS} or V _{CC} , V _{IN} =V _{IL} or V _{IH} , LB# ≤ 0.2V or/and UB# ≤ 0.2V	-	-	22	mA
Standby Current (CMOS)	I _{SB1} (Note)	CS1# ≥ V _{CC} -0.2V, CS2 ≥ V _{CC} -0.2V (CS1# controlled) or CS2 ≤ 0.2V (CS2 controlled), BYTE# = V _{SS} or V _{CC} , Other input = 0~V _{CC}	-	3.0 (Note)	10	μA

Note: Typical values are not 100% tested.

DC Operating Characteristics 8M Version C

Item	Symbol	Test Conditions	Min	Typ (Note)	Max	Unit
Average operating current	I_{CC1}	Cycle time=1 μ s, 100% duty, $I_{IO}=0$ mA, $CS1\# \leq 0.2$ V, $CS2 \geq V_{CC}-0.2$ V, $BYTE\# = V_{SS}$ or V_{CC} , $V_{IN} \leq 0.2$ V or $V_{IN} \geq V_{CC}-0.2$ V, $LB\# \leq 0.2$ V or/and $UB\# \leq 0.2$ V	-	-	3	mA
	I_{CC2}	Cycle time=Min, $I_{IO}=0$ mA, 100% duty, $CS1\# = V_{IL}$, $CS2=V_{IH}$, $BYTE\# = V_{SS}$ or V_{CC} , $V_{IN}=V_{IL}$ or V_{IH} , $LB\# \leq 0.2$ V or/and $UB\# \leq 0.2$ V	-	-	22	mA
Standby Current (CMOS)	I_{SB1} (Note)	$CS1\# \geq V_{CC}-0.2$ V, $CS2 \geq V_{CC}-0.2$ V (CS1# controlled) or $CS2 \leq 0.2$ V (CS2 controlled), $BYTE\# = V_{SS}$ or V_{CC} , Other input = $0 \sim V_{CC}$	-	-	15	μ A

Note: Typical values are not 100% tested.

DC Operating Characteristics 8M Version D

Item	Symbol	Test Conditions	Min	Typ (Note)	Max	Unit
Average operating current	I_{CC1}	Cycle time=1 μ s, 100% duty, $I_{IO}=0$ mA, $CS1\# \leq 0.2$ V, $CS2 \geq V_{CC}-0.2$ V, $BYTE\# = V_{SS}$ or V_{CC} , $V_{IN} \leq 0.2$ V or $V_{IN} \geq V_{CC}-0.2$ V, $LB\# \leq 0.2$ V or/and $UB\# \leq 0.2$ V	-	-	TBD	mA
	I_{CC2}	Cycle time=Min, $I_{IO}=0$ mA, 100% duty, $CS1\# = V_{IL}$, $CS2=V_{IH}$, $BYTE\# = V_{SS}$ or V_{CC} , $V_{IN}=V_{IL}$ or V_{IH} , $LB\# \leq 0.2$ V or/and $UB\# \leq 0.2$ V	-	-	TBD	mA
Standby Current (CMOS)	I_{SB1} (Note)	$CS1\# \geq V_{CC}-0.2$ V, $CS2 \geq V_{CC}-0.2$ V (CS1# controlled) or $CS2 \leq 0.2$ V (CS2 controlled), $BYTE\# = V_{SS}$ or V_{CC} , Other input = $0 \sim V_{CC}$	-	-	TBD	μ A

Note: Typical values are not 100% tested.

AC Operating Conditions

Test Conditions

Test Load and Test Input/Output Reference

- Input pulse level: 0.4 to 2.2V
- Input rising and falling time: 5ns
- Input and output reference voltage: 1.5V
- Output load (See Figure 79): CL= 30pF+1TTL

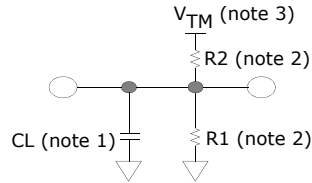

Figure 79. AC Output Load

Notes:

1. Including scope and jig capacitance.
2. $R1=3070\Omega$, $R2=3150\Omega$.
3. $V_{TM} = 2.8V$.

AC Characteristics

Read/Write Characteristics ($V_{CC}=2.7-3.3V$)

Parameter List		Symbol	Speed Bins		Units
			70ns		
			Min	Max	
Read	Read cycle time	t_{RC}	70	-	ns
	Address access time	t_{AA}	-	70	ns
	Chip select to output	t_{CO1}, t_{CO2}	-	70	ns
	Output enable to valid output	t_{OE}	-	35	ns
	LB#, UB# Access Time	t_{BA}	-	70	ns
	Chip select to low-Z output	t_{LZ1}, t_{LZ2}	10	-	ns
	LB#, UB# enable to low-Z output	t_{BLZ}	10	-	ns
	Output enable to low-Z output	t_{OLZ}	5	-	ns
	Chip disable to high-Z output	t_{HZ1}, t_{HZ2}	0	25	ns
	UB#, LB# disable to high-Z output	t_{BHZ}	0	25	ns
	Output disable to high-Z output	t_{OHZ}	0	25	ns
	Output hold from address change	t_{OH}	10	-	ns

Parameter List		Symbol	Speed Bins		Units
			70ns		
			Min	Max	
Write	Write cycle time	t_{WC}	70	-	ns
	Chip select to end of write	t_{CW}	60	-	ns
	Address set-up time	t_{AS}	0	-	ns
	Address valid to end of write	t_{AW}	60	-	ns
	LB#, UB# valid to end of write	t_{BW}	60	-	ns
	Write pulse width	t_{WP}	50	-	ns
	Write recovery time	t_{WR}	0	-	ns
	Write to output high-Z	t_{WHZ}	0	20	ns
	Data to write time overlap	t_{DW}	30	-	ns
	Data hold from write time	t_{DH}	0	-	ns
	End write to output low-Z	t_{OW}	5	-	ns

Data Retention Characteristics (4M Version F)

Item	Symbol	Test Condition	Min	Typ	Max	Unit
V _{CC} for data retention	V _{DR}	CS1# ≥ V _{CC} -0.2V (Note 1), V _{IN} ≥ 0V. BYTE# = V _{SS} or V _{CC}	1.5	-	3.3	V
Data retention current	I _{DR}	V _{CC} =3.0V, CS1# ≥ V _{CC} -0.2V (Note 1), V _{IN} ≥ 0V	-	1.0 (Note 2)	10	μA
Data retention set-up time	t _{SDR}	See data retention waveform	0	-	-	ns
Recovery time	t _{RDR}		t _{RC}	-	-	

Notes:

1. CS1 controlled: CS1# ≥ V_{CC}-0.2V. CS2 controlled: CS2 ≤ 0.2V.
2. Typical values are not 100% tested.

Data Retention Characteristics (4M Version G)

Item	Symbol	Test Condition	Min	Typ	Max	Unit
V _{CC} for data retention	V _{DR}	CS1# ≥ V _{CC} -0.2V (Note 1), V _{IN} ≥ 0V. BYTE# = V _{SS} or V _{CC}	1.5	-	3.3	V
Data retention current	I _{DR}	V _{CC} =1.5V, CS1# ≥ V _{CC} -0.2V (Note 1), V _{IN} ≥ 0V	-	-	3	μA
Data retention set-up time	t _{SDR}	See data retention waveform	0	-	-	ns
Recovery time	t _{RDR}		t _{RC}	-	-	

Notes:

1. CS1 controlled: CS1# ≥ V_{CC}-0.2V. CS2 controlled: CS2 ≤ 0.2V.

Data Retention Characteristics (8M Version C)

Item	Symbol	Test Condition	Min	Typ	Max	Unit
V _{CC} for data retention	V _{DR}	CS1# ≥ V _{CC} -0.2V (Note 1). BYTE# = V _{SS} or V _{CC}	1.5	-	3.3	V
Data retention current	I _{DR}	V _{CC} =3.0V, CS1# ≥ V _{CC} -0.2V (Note 1)	-	-	15	μA
Data retention set-up time	t _{SDR}	See data retention waveform	0	-	-	ns
Recovery time	t _{RDR}		t _{RC}	-	-	

Notes:

1. CS1 controlled: CS1# ≥ V_{CC}-0.2V. CS2 controlled: CS2 ≤ 0.2V.

Data Retention Characteristics (8M Version D)

Item	Symbol	Test Condition	Min	Typ	Max	Unit
V _{CC} for data retention	V _{DR}	CS1# ≥ V _{CC} -0.2V (Note 1), BYTE# = V _{SS} or V _{CC}	1.5	-	3.3	V
Data retention current	I _{DR}	V _{CC} =3.0V, CS1# ≥ V _{CC} -0.2V (Note 1)	-	-	TBD	μA
Data retention set-up time	t _{SDR}	See data retention waveform	0	-	-	ns
Recovery time	t _{RDR}		t _{RC}	-	-	

Notes:

1. CS1 controlled: CS1# ≥ V_{CC}-0.2V. CS2 controlled: CS2 ≤ 0.2V.

Timing Diagrams

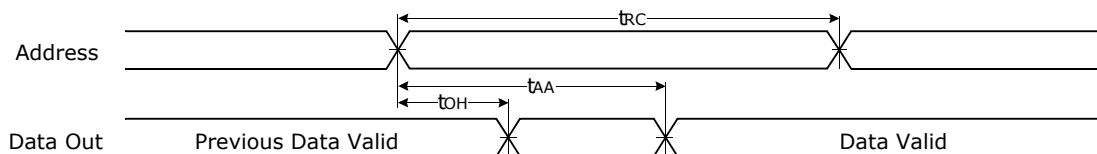

Figure 80. Timing Waveform of Read Cycle(I) (Address Controlled, CS#I=OE#=V_{IL}, CS2=WE#=V_{IH}, UB# and/or LB#=V_{IL})

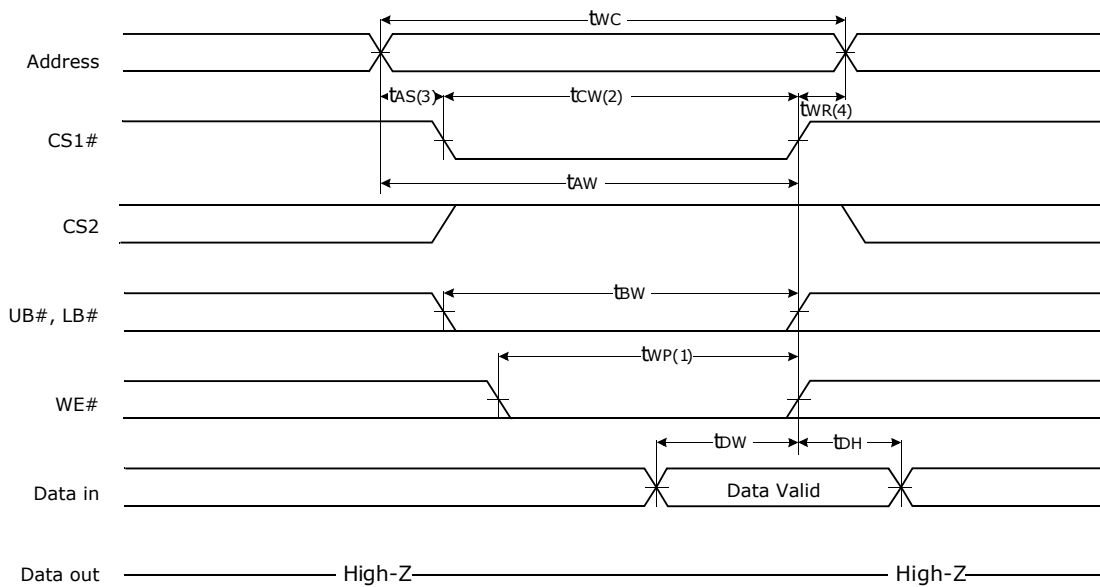
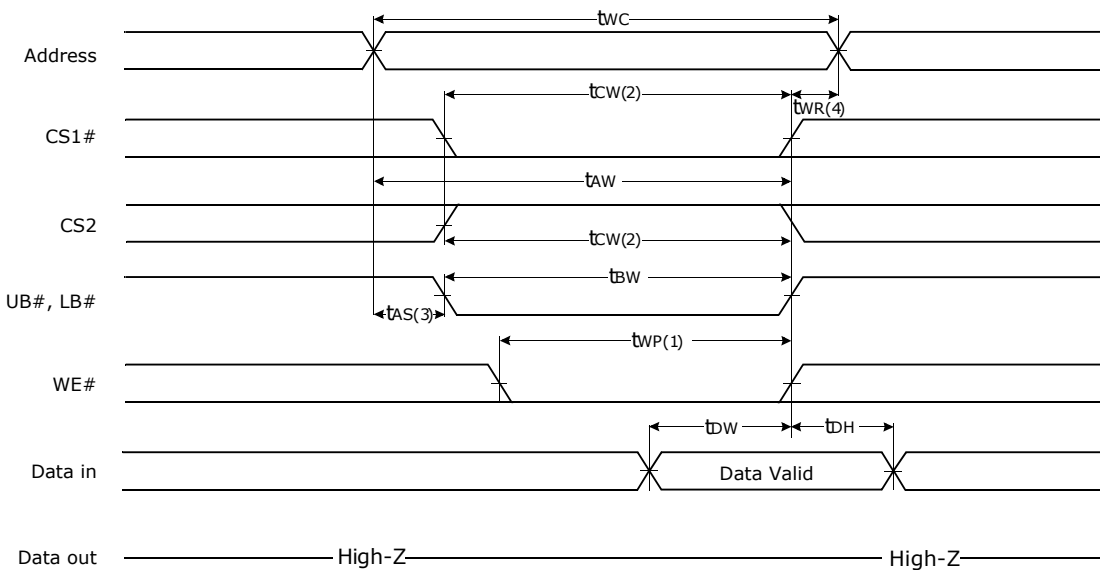

Figure 83. Timing Waveform of Write Cycle(2) (CS# controlled, if BYTE# is Low, Ignore UB#/LB# Timing)



Notes:

1. A write occurs during the overlap (t_{WP}) of low CS1# and low WE#. A write begins when CS1# goes low and WE# goes low with asserting UB# or LB# for single byte operation or simultaneously asserting UB# and LB# for double byte operation. A write ends at the earliest transition when CS1# goes high and WE# goes high. The t_{WP} is measured from the beginning of write to the end of write.
2. t_{CW} is measured from the CS1# going low to the end of write.
3. t_{AS} is measured from the address valid to the beginning of write.
4. t_{WR} is measured from the end of write to the address change. t_{WR} applied in case a write ends as CS1# or WE# going high.

Figure 84. Timing Waveform of Write Cycle(3) (UB#, LB# controlled)

CS1# Controlled

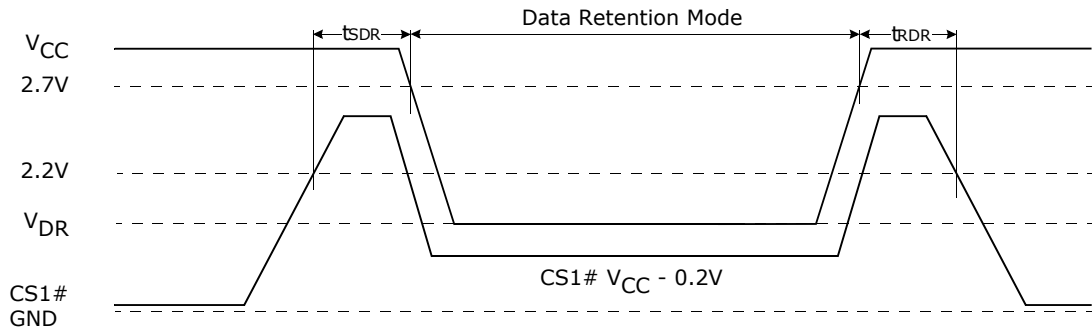

CS2 Controlled

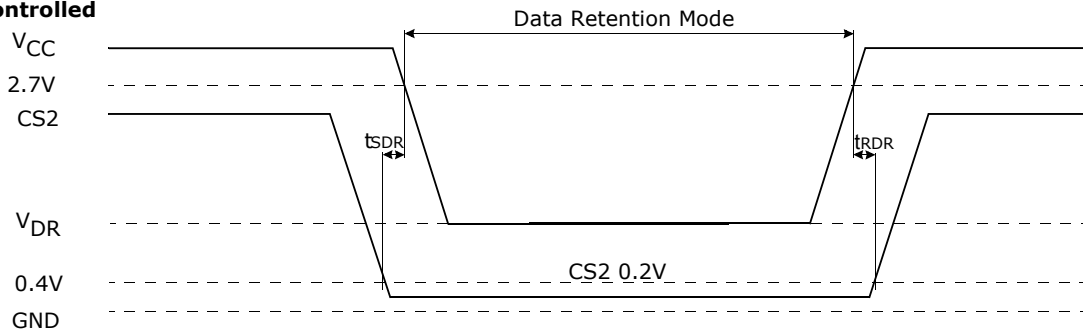

Figure 85. Data Retention Waveform

pSRAM Type I

4Mbit (256K Word x 16-bit)

8Mbit (512K Word x 16-bit)

16Mbit (1M Word x 16-bit)

32Mbit (2M Word x 16-bit)

64Mbit (4M Word x 16-bit)

Features

- Fast Cycle Times
 - $T_{ACC} < 70$ nS
 - $T_{ACC} < 65$ nS
 - $T_{ACC} < 60$ nS
 - $T_{ACC} < 55$ nS
- Very low standby current
 - $I_{SB} < 120$ μ A (64M and 32M)
 - $I_{SB} < 100$ μ A (16M)
- Very low operating current
 - $I_{CC} < 25$ mA

Functional Description

Mode	CE#	CE2/ZZ#	OE#	WE#	UB#	LB#	Addresses	I/O 1-8	I/O 9-16	Power
Read (word)	L	H	L	H	L	L	X	Dout	Dout	I_{ACTIVE}
Read (lower byte)	L	H	L	H	H	L	X	Dout	High-Z	I_{ACTIVE}
Read (upper byte)	L	H	L	H	L	H	X	High-Z	Dout	I_{ACTIVE}
Write (word)	L	H	X	L	L	L	X	Din	Din	I_{ACTIVE}
Write (lower byte)	L	H	X	L	H	L	X	Din	Invalid	I_{ACTIVE}
Write (upper byte)	L	H	X	L	L	H	X	Invalid	Din	I_{ACTIVE}
Outputs disabled	L	H	H	H	X	X	X	High-Z	High-Z	I_{ACTIVE}
Standby	H	H	X	X	X	X	X	High-Z	High-Z	$I_{STANDBY}$
Deep power down	H	L	X	X	X	X	X	High-Z	High-Z	$I_{DEEP SLEEP}$

Absolute Maximum Ratings

Item	Symbol	Ratings	Units
Voltage on any pin relative to V_{SS}	V_{in}, V_{out}	-0.2 to $V_{CC} + 0.3$	V
Voltage on V_{CC} relative to V_{SS}	V_{CC}	-0.2 to 3.6	V
Power dissipation	P_D	1	W
Storage temperature	T_{STG}	-55 to 150	$^{\circ}$ C
Operating temperature	T_A	-25 to 85	$^{\circ}$ C

DC Characteristics (4Mb pSRAM Asynchronous)

Performance Grade			Asynchronous		
			-70		
Density			4Mb pSRAM		
Symbol	Parameter	Conditions	Min	Max	Units
V _{CC}	Power Supply		2.7	3.3	V
V _{IH}	Input High Level		1.4 V _{CCq}	V _{CC} + 0.3	V
V _{IL}	Input Low Level		-0.3	0.4	V
I _{IL}	Input Leakage Current	V _{in} = 0 to V _{CC}		0.5	μA
I _{LO}	Output Leakage Current	OE = V _{IH} or Chip Disabled		0.5	μA
V _{OH}	Output High Voltage	I _{OH} = -1.0 mA			V
		I _{OH} = -0.2 mA	0.8 V _{CCq}		
		I _{OH} = -0.5 mA			
V _{OL}	Output Low Voltage	I _{OL} = 2.0 mA			V
		I _{OL} = 0.2 mA		0.2	
		I _{OL} = 0.5 mA			
I _{ACTIVE}	Operating Current	V _{CC} = 3.3 V		25	mA
I _{STANDBY}	Standby Current	V _{CC} = 3.0 V		70	μA
		V _{CC} = 3.3 V			
I _{DEEP SLEEP}	Deep Power Down Current			x	μA
I _{PAR 1/4}	1/4 Array PAR Current			x	μA
I _{PAR 1/2}	1/2 Array PAR Current			x	μA

DC Characteristics (8Mb pSRAM Asynchronous)

Version			Asynchronous								
			B						C		
Performance Grade			-55			-70			-70		
Density			8Mb pSRAM			8Mb pSRAM			8Mb pSRAM		
Symbol	Parameter	Conditions	Min	Max	Units	Min	Max	Units	Min	Max	Units
V _{CC}	Power Supply		2.7	3.3	V	2.7	3.6	V	2.7	3.3	V
V _{IH}	Input High Level		2.2	V _{CC} + 0.3	V	2.2	V _{CC} + 0.3	V	1.4	V _{CC} +0.3	V
V _{IL}	Input Low Level		-0.3	0.6	V	-0.3	0.6	V	-0.3	0.4	V
I _{IL}	Input Leakage Current	V _{in} = 0 to V _{CC}		0.5	μA		0.5	μA		0.5	μA
I _{LO}	Output Leakage Current	OE = V _{IH} or Chip Disabled		0.5	μA		0.5	μA		0.5	μA
V _{OH}	Output High Voltage	I _{OH} = -1.0 mA	V _{CC} -0.4		V	V _{CC} -0.4		V	0.8 V _{CCQ}		V
		I _{OH} = -0.2 mA									
		I _{OH} = -0.5 mA									
V _{OL}	Output Low Voltage	I _{OL} = 2.0 mA		0.4	V		0.4	V		0.2	V
		I _{OL} = 0.2 mA									
		I _{OL} = 0.5 mA									
I _{ACTIVE}	Operating Current	V _{CC} = 3.3 V		25	mA		23	mA		25	mA
I _{STANDBY}	Standby Current	V _{CC} = 3.0 V		60	μA		60	μA		60	μA
		V _{CC} = 3.3 V									
I _{DEEP SLEEP}	Deep Power Down Current			x	μA		x	μA		x	μA
I _{PAR 1/4}	1/4 Array PAR Current			x	μA		x	μA		x	μA
I _{PAR 1/2}	1/2 Array PAR Current			x	μA		x	μA		x	μA

DC Characteristics (16Mb pSRAM Asynchronous)

Performance Grade			Asynchronous					
			-55			-70		
Density			16Mb pSRAM			16Mb pSRAM		
Symbol	Parameter	Conditions	Minimum	Maximum	Units	Minimum	Maximum	Units
V _{CC}	Power Supply		2.7	3.6	V	2.7	3.6	V
V _{IH}	Input High Level		2.2	V _{CC} + 0.3	V	2.2	V _{CC} + 0.3	V
V _{IL}	Input Low Level		-0.3	0.6	V	-0.3	0.6	V
I _{IL}	Input Leakage Current	V _{in} = 0 to V _{CC}		0.5	μA		0.5	μA
I _{LO}	Output Leakage Current	OE = V _{IH} or Chip Disabled		0.5	μA		0.5	μA
V _{OH}	Output High Voltage	I _{OH} = -1.0 mA	V _{CC} -0.4		V	V _{CC} -0.4		V
		I _{OH} = -0.2 mA						
		I _{OH} = -0.5 mA						
V _{OL}	Output Low Voltage	I _{OL} = 2.0 mA		0.4	V		0.4	V
		I _{OL} = 0.2 mA						
		I _{OL} = 0.5 mA						
I _{ACTIVE}	Operating Current	V _{CC} = 3.3 V		25	mA		23	mA
I _{STANDBY}	Standby Current	V _{CC} = 3.0 V		100	μA		100	μA
		V _{CC} = 3.3 V						
I _{DEEP SLEEP}	Deep Power Down Current			x	μA		x	μA
I _{PAR 1/4}	1/4 Array PAR Current			x	μA		x	μA
I _{PAR 1/2}	1/2 Array PAR Current			x	μA		x	μA

DC Characteristics (16Mb pSRAM Page Mode)

Performance Grade			Page Mode								
			-60			-65			-70		
Density			16Mb pSRAM			16Mb pSRAM			16Mb pSRAM		
Symbol	Parameter	Conditions	Min	Max	Units	Min	Max	Units	Min	Max	Units
V _{CC}	Power Supply		2.7	3.3	V	2.7	3.3	V	2.7	3.3	V
V _{IH}	Input High Level		0.8 V _{CCq}	V _{CC} + 0.2	V	0.8 V _{CCq}	V _{CC} + 0.2	V	0.8 V _{CCq}	V _{CC} + 0.2	V
V _{IL}	Input Low Level		-0.2	0.2 V _{CCq}	V	-0.2	0.2 V _{CCq}	V	-0.2	0.2 V _{CCq}	V
I _{IL}	Input Leakage Current	V _{in} = 0 to V _{CC}		1	μA		1	μA		1	μA
I _{LO}	Output Leakage Current	OE = V _{IH} or Chip Disabled		1	μA		1	μA		1	μA
V _{OH}	Output High Voltage	I _{OH} = -1.0 mA			V			V			V
		I _{OH} = -0.2 mA									
		I _{OH} = -0.5 mA	0.8 V _{CCq}			0.8 V _{CCq}			0.8 V _{CCq}		
V _{OL}	Output Low Voltage	I _{OL} = 2.0 mA			V			V			V
		I _{OL} = 0.2 mA									
		I _{OL} = 0.5 mA		0.2 V _{CCq}			0.2 V _{CCq}			0.2 V _{CCq}	
I _{ACTIVE}	Operating Current	V _{CC} = 3.3 V		25	mA		25	mA		25	mA
I _{STANDBY}	Standby Current	V _{CC} = 3.0 V			μA			μA			μA
		V _{CC} = 3.3 V		100			100			100	
I _{DEEP SLEEP}	Deep Power Down Current			10	μA		10	μA		10	μA
I _{PAR 1/4}	1/4 Array PAR Current			65	μA		65	μA		65	μA
I _{PAR 1/2}	1/2 Array PAR Current			80	μA		80	μA		80	μA

DC Characteristics (32Mb pSRAM Page Mode)

Version			Page Mode											
			C			-60			-65			-70		
Performance Grade			-65			-60			-65			-70		
Density			32Mb pSRAM			32Mb pSRAM			32Mb pSRAM			32Mb pSRAM		
Symbol	Parameter	Conditions	Min	Max	Units	Min	Max	Units	Min	Max	Units	Min	Max	Units
V _{CC}	Power Supply		2.7	3.6	V	2.7	3.3	V	2.7	3.3	V	2.7	3.3	V
V _{IH}	Input High Level		1.4	V _{CC} + 0.2	V	0.8 V _{CCq}	V _{CC} + 0.2	V	0.8 V _{CCq}	V _{CC} + 0.2	V	0.8 V _{CCq}	V _{CC} + 0.2	V
V _{IL}	Input Low Level		-0.2	0.4	V	-0.2	0.2 V _{CCq}	V	-0.2	0.2 V _{CCq}	V	-0.2	0.2 V _{CCq}	V
I _{IL}	Input Leakage Current	V _{in} = 0 to V _{CC}		0.5	μA		1	μA		1	μA		1	μA
I _{LO}	Output Leakage Current	OE = V _{IH} or Chip Disabled		0.5	μA		1	μA		1	μA		1	μA
V _{OH}	Output High Voltage	I _{OH} = -1.0 mA			V			V			V			V
		I _{OH} = -0.2 mA	0.8 V _{CCq}											
		I _{OH} = -0.5 mA				0.8 V _{CCq}			0.8 V _{CCq}			0.8 V _{CCq}		
V _{OL}	Output Low Voltage	I _{OL} = 2.0 mA			V			V			V			V
		I _{OL} = 0.2 mA		0.2										
		I _{OL} = 0.5 mA					0.2 V _{CCq}			0.2 V _{CCq}			0.2 V _{CCq}	
I _{ACTIVE}	Operating Current	V _{CC} = 3.3 V		25	mA		25	mA		25	mA		25	mA
I _{STANDBY}	Standby Current	V _{CC} = 3.0 V			μA			μA			μA			μA
		V _{CC} = 3.3 V		100			120			120			100	
I _{DEEP SLEEP}	Deep Power Down Current			10	μA		10	μA		10	μA		10	μA
I _{PAR 1/4}	1/4 Array PAR Current			65	μA		75	μA		75	μA		65	μA
I _{PAR 1/2}	1/2 Array PAR Current			80	μA		90	μA		90	μA		80	μA

DC Characteristics (64Mb pSRAM Page Mode)

Performance Grade			Page Mode		
			-70		
Density			64Mb pSRAM		
Symbol	Parameter	Conditions	Min	Max	Units
V _{CC}	Power Supply		2.7	3.3	V
V _{IH}	Input High Level		0.8 V _{CCq}	V _{CC} + 0.2	V
V _{IL}	Input Low Level		-0.2	0.2 V _{CCq}	V
I _{IL}	Input Leakage Current	V _{in} = 0 to V _{CC}		1	μA
I _{LO}	Output Leakage Current	OE = V _{IH} or Chip Disabled		1	μA
V _{OH}	Output High Voltage	I _{OH} = -1.0 mA			V
		I _{OH} = -0.2 mA			
		I _{OH} = -0.5 mA	0.8 V _{CCq}		
V _{OL}	Output Low Voltage	I _{OL} = 2.0 mA			V
		I _{OL} = 0.2 mA			
		I _{OL} = 0.5 mA		0.2 V _{CCq}	
I _{ACTIVE}	Operating Current	V _{CC} = 3.3 V		25	mA
I _{STANDBY}	Standby Current	V _{CC} = 3.0 V			μA
		V _{CC} = 3.3 V		120	
I _{DEEP SLEEP}	Deep Power Down Current			10	μA
I _{PAR 1/4}	1/4 Array PAR Current			65	μA
I _{PAR 1/2}	1/2 Array PAR Current			80	μA

Timing Test Conditions

Item	
Input Pulse Level	0.1 V _{CC} to 0.9 V _{CC}
Input Rise and Fall Time	5ns
Input and Output Timing Reference Levels	0.5 V _{CC}
Operating Temperature	-25°C to +85°C

Output Load Circuit

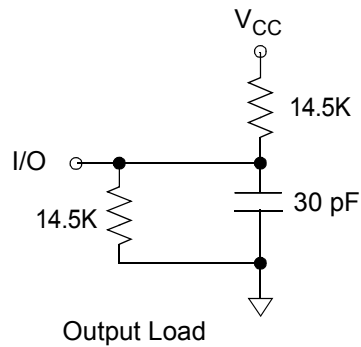

Figure 86. Output Load Circuit

Power Up Sequence

After applying power, maintain a stable power supply for a minimum of 200 μ s after $CE\# > V_{IH}$.

AC Characteristics (4Mb pSRAM Page Mode)

Performance Grade			Asynchronous		
			-70		
Density			4Mb pSRAM		
3 Volt	Symbol	Parameter	Min	Max	Units
Read	trc	Read cycle time	70		ns
	taa	Address Access Time		70	ns
	tco	Chip select to output		70	ns
	toe	Output enable to valid output		20	ns
	tba	UB#, LB# Access time		70	ns
	tlz	Chip select to Low-z output	10		ns
	tblz	UB#, LB# Enable to Low-Z output	10		ns
	tolz	Output enable to Low-Z output	5		ns
	thz	Chip enable to High-Z output	0	20	ns
	tbhz	UB#, LB# disable to High-Z output	0	20	ns
	tohz	Output disable to High-Z output	0	20	ns
	toh	Output hold from Address Change	10		ns

Performance Grade			Asynchronous		
			-70		
Density			4Mb pSRAM		
3 Volt	Symbol	Parameter	Min	Max	Units
Write	twc	Write cycle time	70		ns
	tcw	Chipselect to end of write	70		ns
	tas	Address set up Time	0		ns
	taw	Address valid to end of write	70		ns
	tbw	UB#, LB# valid to end of write	70		ns
	twp	Write pulse width	55		ns
	twr	Write recovery time	0		ns
	twhz	Write to output High-Z		20	ns
	tdw	Data to write time overlap	25		ns
	tdh	Data hold from write time	0		ns
	tow	End write to output Low-Z	5		
tow	Write high pulse width	7.5		ns	
Other	tpc	Page read cycle	x		
	tpa	Page address access time		x	
	twpc	Page write cycle	x		
	tcp	Chip select high pulse width	x		

AC Characteristics (8Mb pSRAM Asynchronous)

			Asynchronous								
Version			B						C		
Performance Grade			-55			-70			-70		
Density			8Mb pSRAM			8Mb pSRAM			8Mb pSRAM		
3 Volt	Symbol	Parameter	Min	Max	Units	Min	Max	Units	Min	Max	Units
Read	trc	Read cycle time	55		ns	70		ns	70		ns
	taa	Address Access Time		55	ns		70	ns		70	ns
	tco	Chip select to output		55	ns		70	ns		70	ns
	toe	Output enable to valid output		30	ns		35	ns		20	ns
	tba	UB#, LB# Access time		55	ns		70	ns		70	ns
	tlz	Chip select to Low-z output	5		ns	5		ns	10		ns
	tblz	UB#, LB# Enable to Low-Z output	5		ns	5		ns	10		ns
	tolz	Output enable to Low-Z output	5		ns	5		ns	5		ns
	thz	Chip enable to High-Z output	0	20	ns	0	25	ns	0	20	ns
	tbhz	UB#, LB# disable to High-Z output	0	20	ns	0	25	ns	0	20	ns
	tohz	Output disable to High-Z output	0	20	ns	0	25	ns	0	20	ns
	toh	Output hold from Address Change	10		ns	10		ns	10		ns

			Asynchronous								
Version			B						C		
Performance Grade			-55			-70			-70		
Density			8Mb pSRAM			8Mb pSRAM			8Mb pSRAM		
3 Volt	Symbol	Parameter	Min	Max	Units	Min	Max	Units	Min	Max	Units
Write	twc	Write cycle time	55		ns	70		ns	70		ns
	tcw	Chip select to end of write	45		ns	55		ns	70		ns
	tas	Address set up Time	0		ns	0		ns	0		ns
	taw	Address valid to end of write	45		ns	55		ns	70		ns
	tbw	UB#, LB# valid to end of write	45		ns	55		ns	70		ns
	twp	Write pulse width	45		ns	55		ns	55		ns
	twr	Write recovery time	0		ns	0		ns	0		ns
	twhz	Write to output High-Z		25	ns		25			20	ns
	tdw	Data to write time overlap	40		ns	40		ns	25		ns
	tdh	Data hold from write time	0		ns	0		ns	0		ns
	tow	End write to output Low-Z	5			5			5		
	tow	Write high pulse width	x	x	ns	x	x	ns	x	x	ns
Other	tpc	Page read cycle	x			x			x		
	tpa	Page address access time		x			x			x	
	twpc	Page write cycle	x			x			x		
	tcp	Chip select high pulse width	x			x			x		

AC Characteristics (16Mb pSRAM Asynchronous)

Performance Grade			Asynchronous					
			-55			-70		
Density			16Mb pSRAM			16Mb pSRAM		
3 Volt	Symbol	Parameter	Min	Max	Units	Min	Max	Units
Read	trc	Read cycle time	55		ns	70		ns
	taa	Address Access Time		55	ns		70	ns
	tco	Chip select to output		55	ns		70	ns
	toe	Output enable to valid output		30	ns		35	ns
	tba	UB#, LB# Access time		55	ns		70	ns
	tlz	Chip select to Low-z output	5		ns	5		ns
	tblz	UB#, LB# Enable to Low-Z output	5		ns	5		ns
	tolz	Output enable to Low-Z output	5		ns	5		ns
	thz	Chip enable to High-Z output	0	25	ns	0	25	ns
	tbhz	UB#, LB# disable to High-Z output	0	25	ns	0	25	ns
	tohz	Output disable to High-Z output	0	25	ns	0	25	ns
	toh	Output hold from Address Change	10		ns	10		ns

Performance Grade			Asynchronous					
			-55			-70		
Density			16Mb pSRAM			16Mb pSRAM		
3 Volt	Symbol	Parameter	Min	Max	Units	Min	Max	Units
Write	twc	Write cycle time	55		ns	70		ns
	tcw	Chipselect to end of write	50		ns	55		ns
	tas	Address set up Time	0		ns	0		ns
	taw	Address valid to end of write	50		ns	55		ns
	tbw	UB#, LB# valid to end of write	50		ns	55		ns
	twp	Write pulse width	50		ns	55		ns
	twr	Write recovery time	0		ns	0		ns
	twhz	Write to output High-Z		25	ns		25	ns
	tdw	Data to write time overlap	25		ns	25		ns
	tdh	Data hold from write time	0		ns	0		ns
	tow	End write to output Low-Z	5			5		
	tow	Write high pulse width	x	x	ns	x	x	ns
Other	tpc	Page read cycle	x			x		
	tpa	Page address access time		x			x	
	twpc	Page write cycle	x			x		
	tcp	Chip select high pulse width	x			x		

AC Characteristics (16Mb pSRAM Page Mode)

Performance Grade			Page Mode								
			-60			-65			-70		
Density			16Mb pSRAM			16Mb pSRAM			16Mb pSRAM		
3 Volt	Symbol	Parameter	Min	Max	Units	Min	Max	Units	Min	Max	Units
Read	trc	Read cycle time	60	20k	ns	65	20k	ns	70	20k	ns
	taa	Address Access Time		60	ns		65	ns		70	ns
	tco	Chip select to output		60	ns		65	ns		70	ns
	toe	Output enable to valid output		25	ns		25	ns		25	ns
	tba	UB#, LB# Access time		60	ns		65	ns		70	ns
	tlz	Chip select to Low-z output	10		ns	10		ns	10		ns
	tblz	UB#, LB# Enable to Low-Z output	10		ns	10		ns	10		ns
	tolz	Output enable to Low-Z output	5		ns	5		ns	5		ns
	thz	Chip enable to High-Z output	0	5	ns	0	5	ns	0	5	ns
	tbhz	UB#, LB# disable to High-Z output	0	5	ns	0	5	ns	0	5	ns
	tohz	Output disable to High-Z output	0	5	ns	0	5	ns	0	5	ns
	toh	Output hold from Address Change	5		ns	5		ns	5		ns

Performance Grade			Page Mode								
			-60			-65			-70		
Density			16Mb pSRAM			16Mb pSRAM			16Mb pSRAM		
3 Volt	Symbol	Parameter	Min	Max	Units	Min	Max	Units	Min	Max	Units
Write	twc	Write cycle time	60	20k	ns	65	20k	ns	70	20k	ns
	tcw	Chipselect to end of write	50		ns	60		ns	60		ns
	tas	Address set up Time	0		ns	0		ns	0		ns
	taw	Address valid to end of write	50		ns	60		ns	60		ns
	tbw	UB#, LB# valid to end of write	50		ns	60		ns	60		ns
	twp	Write pulse width	50		ns	50		ns	50		ns
	twr	Write recovery time	0		ns	0		ns	0		ns
	twhz	Write to output High-Z		5	ns		5	ns		5	ns
	tdw	Data to write time overlap	20		ns	20		ns	20		ns
	tdh	Data hold from write time	0		ns	0		ns	0		ns
	tow	End write to output Low-Z	5			5			5		
tow	Write high pulse width	7.5		ns	7.5		ns	7.5		ns	
Other	tpc	Page read cycle	25	20k	ns	25	20k	ns	25	20k	ns
	tpa	Page address access time		25	ns		25	ns		25	ns
	twpc	Page write cycle	25	20k	ns	25	20k	ns	25	20k	ns
	tcp	Chip select high pulse width	10		ns	10		ns	10		ns

AC Characteristics (32Mb pSRAM Page Mode)

Version			Page Mode											
			C			E								
Performance Grade			-65			-60			-65			-70		
Density			32Mb pSRAM			32Mb pSRAM			32Mb pSRAM			32Mb pSRAM		
3 Volt	Symbol	Parameter	Min	Max	Units	Min	Max	Units	Min	Max	Units	Min	Max	Units
Read	trc	Read cycle time	65	20k	ns	60	20k	ns	65	20k	ns	70	20k	ns
	taa	Address Access Time		65	ns		60	ns		65	ns		70	ns
	tco	Chip select to output		65	ns		60	ns		65	ns		70	ns
	toe	Output enable to valid output		20	ns		25	ns		25	ns		25	ns
	tba	UB#, LB# Access time		65	ns		60	ns		65	ns		70	ns
	tlz	Chip select to Low-z output	10		ns	10		ns	10		ns	10		ns
	tblz	UB#, LB# Enable to Low-Z output	10		ns	10		ns	10		ns	10		ns
	tolz	Output enable to Low-Z output	5		ns	5		ns	5		ns	5		ns
	thz	Chip enable to High-Z output	0	20	ns	0	5	ns	0	5	ns	0	5	ns
	tbhz	UB#, LB# disable to High-Z output	0	20	ns	0	5	ns	0	5	ns	0	5	ns
	tohz	Output disable to High-Z output	0	20	ns	0	5	ns	0	5	ns	0	5	ns
	toh	Output hold from Address Change	5		ns	5		ns	5		ns	5		ns

			Page Mode											
Version			C			E								
Performance Grade			-65			-60			-65			-70		
Density			32Mb pSRAM			32Mb pSRAM			32Mb pSRAM			32Mb pSRAM		
3 Volt	Symbol	Parameter	Min	Max	Units	Min	Max	Units	Min	Max	Units	Min	Max	Units
Write	twc	Write cycle time	65	20k	ns	60	20k	ns	65	20k	ns	70	20k	ns
	tcw	Chipselect to end of write	55		ns	50		ns	60		ns	60		ns
	tas	Address set up Time	0		ns	0		ns	0		ns	0		ns
	taw	Address valid to end of write	55		ns	50		ns	60		ns	60		ns
	tbw	UB#, LB# valid to end of write	55		ns	50		ns	60		ns	60		ns
	twp	Write pulse width	55	20k	ns	50		ns	50		ns	50		ns
	twr	Write recovery time	0		ns	0		ns	0		ns	0		ns
	twhz	Write to output High-Z		5	ns		5	ns		5	ns		5	ns
	tdw	Data to write time overlap	25		ns	20		ns	20		ns	20		ns
	tdh	Data hold from write time	0		ns	0		ns	0		ns	0		ns
	tow	End write to output Low-Z	5			5			5			5		
	tow	Write high pulse width	7.5		ns	7.5		ns	7.5		ns	7.5		ns
Other	tpc	Page read cycle	25	20k	ns	25	20k	ns	25	20k	ns	25	20k	ns
	tpa	Page address access time		25	ns		25	ns		25	ns		25	ns
	twpc	Page write cycle	25	20k	ns	25	20k	ns	25	20k	ns	25	20k	ns
	tcp	Chip select high pulse width	10		ns	10		ns	10		ns	10		ns

AC Characteristics (64Mb pSRAM Page Mode)

Performance Grade			Page Mode		
			-70		
Density			64Mb pSRAM		
3 Volt	Symbol	Parameter	Min	Max	Units
Read	trc	Read cycle time	70	20k	ns
	taa	Address Access Time		70	ns
	tco	Chip select to output		70	ns
	toe	Output enable to valid output		25	ns
	tba	UB#, LB# Access time		70	ns
	tlz	Chip select to Low-z output	10		ns
	tblz	UB#, LB# Enable to Low-Z output	10		ns
	tolz	Output enable to Low-Z output	5		ns
	thz	Chip enable to High-Z output	0	5	ns
	tbhz	UB#, LB# disable to High-Z output	0	5	ns
	tohz	Output disable to High-Z output	0	5	ns
	toh	Output hold from Address Change	5		ns

Performance Grade			Page Mode		
			-70		
Density			64Mb pSRAM		
3 Volt	Symbol	Parameter	Min	Max	Units
Write	twc	Write cycle time	70	20k	ns
	tcw	Chipselect to end of write	60		ns
	tas	Address set up Time	0		ns
	taw	Address valid to end of write	60		ns
	tbw	UB#, LB# valid to end of write	60		ns
	twp	Write pulse width	50	20k	ns
	twr	Write recovery time	0		ns
	twhz	Write to output High-Z		5	ns
	tdw	Data to write time overlap	20		ns
	tdh	Data hold from write time	0		ns
	tow	End write to output Low-Z	5		
Other	tpc	Page read cycle	20	20k	ns
	tpa	Page address access time		20	ns
	twpc	Page write cycle	20	20k	ns
	tcp	Chip select high pulse width	10		ns

Timing Diagrams

Read Cycle

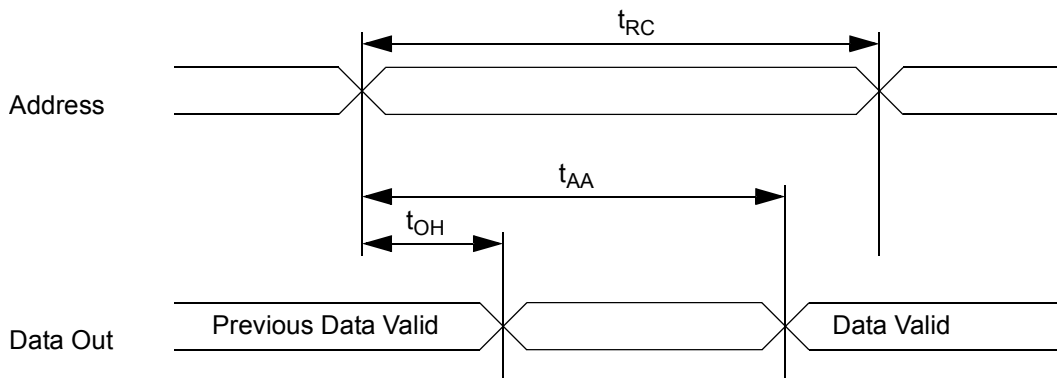

Figure 87. Timing of Read Cycle (CE# = OE# = V_{IL}, WE# = ZZ# = V_{IH})

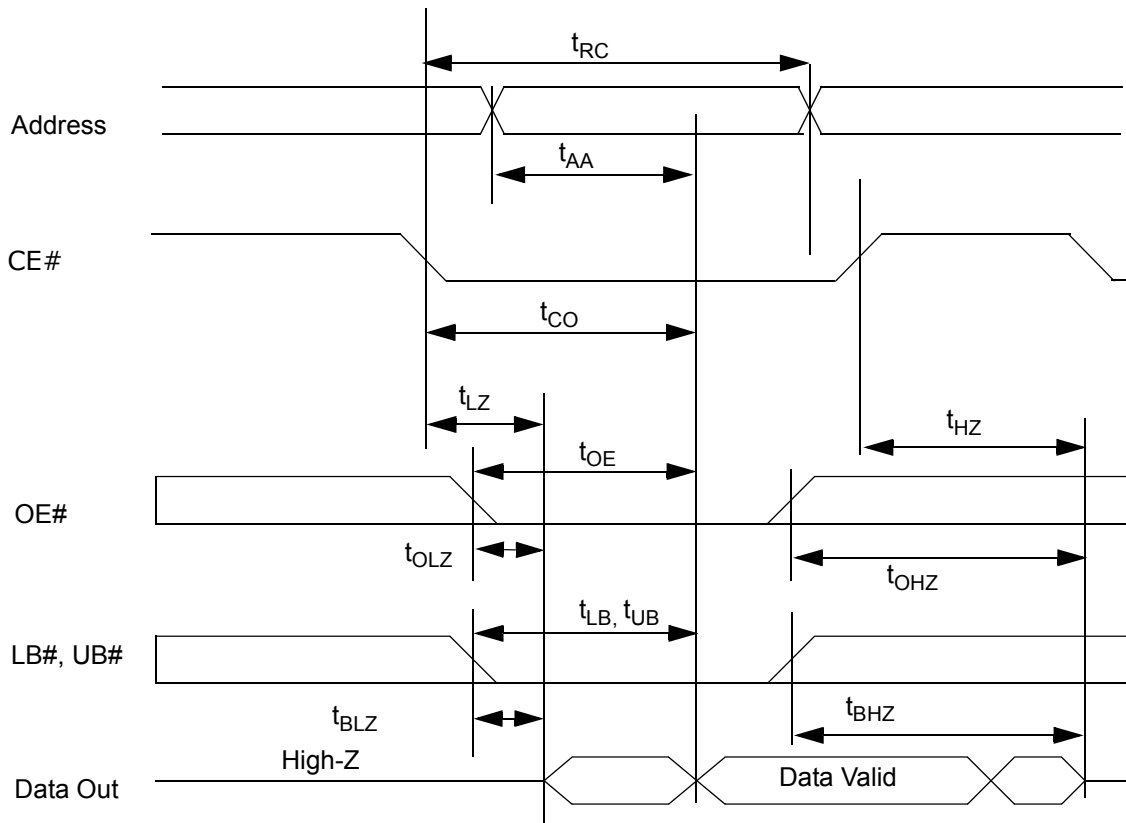

Figure 88. Timing Waveform of Read Cycle ($WE# = ZZ# = V_{IH}$)

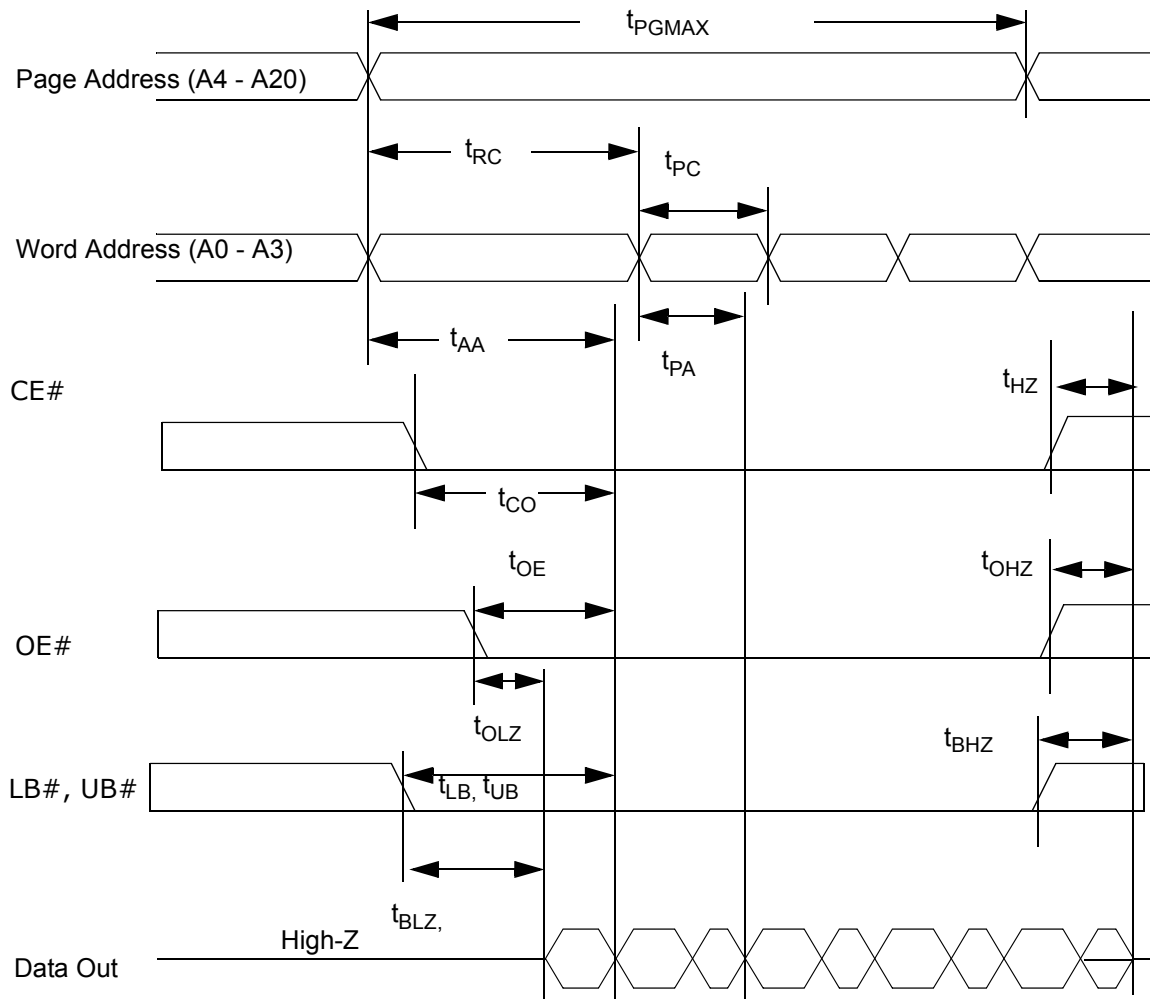

Figure 89. Timing Waveform of Page Mode Read Cycle ($WE\# = ZZ\# = V_{IH}$)

Write Cycle

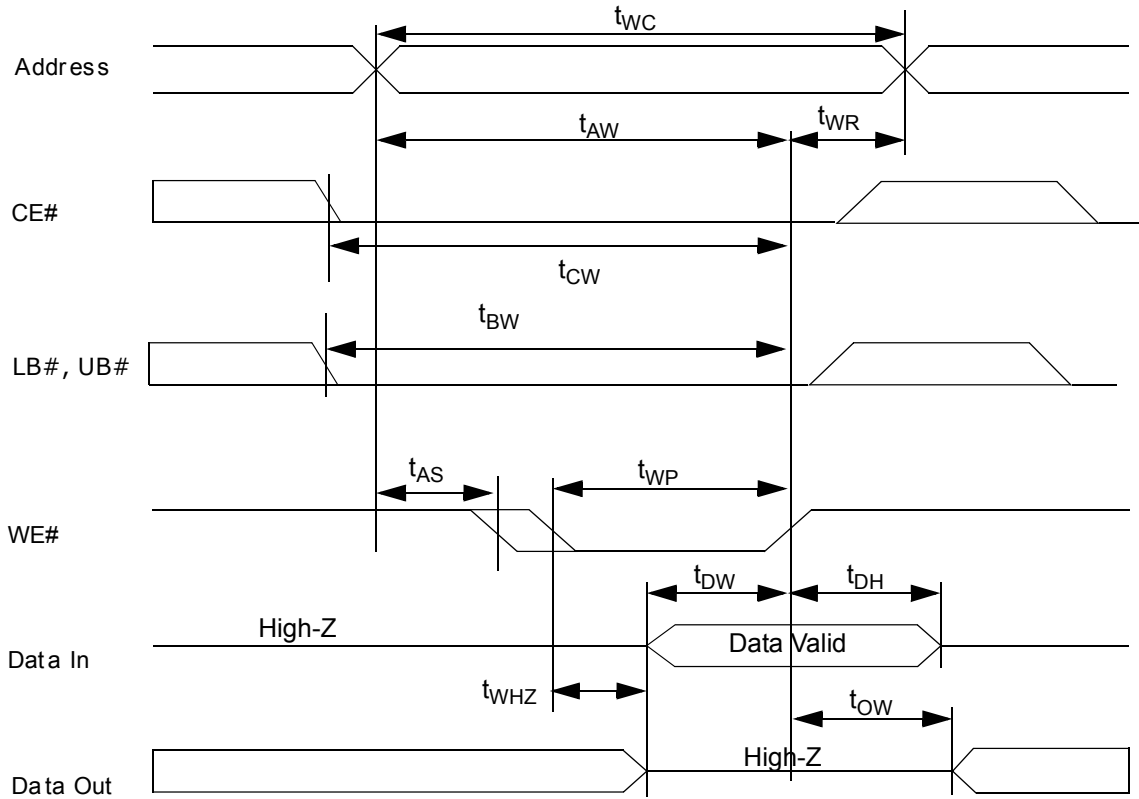

Figure 90. Timing Waveform of Write Cycle (WE# Control, ZZ# = V_{IH})

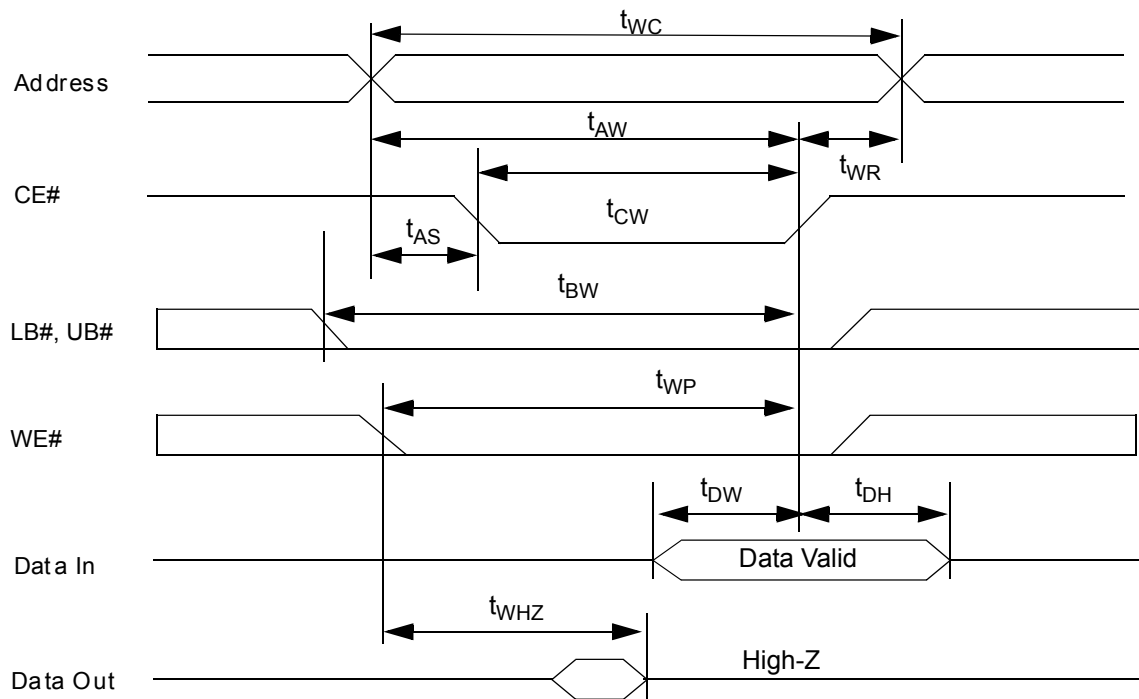

Figure 91. Timing Waveform of Write Cycle (CE# Control, ZZ# = V_{IH})

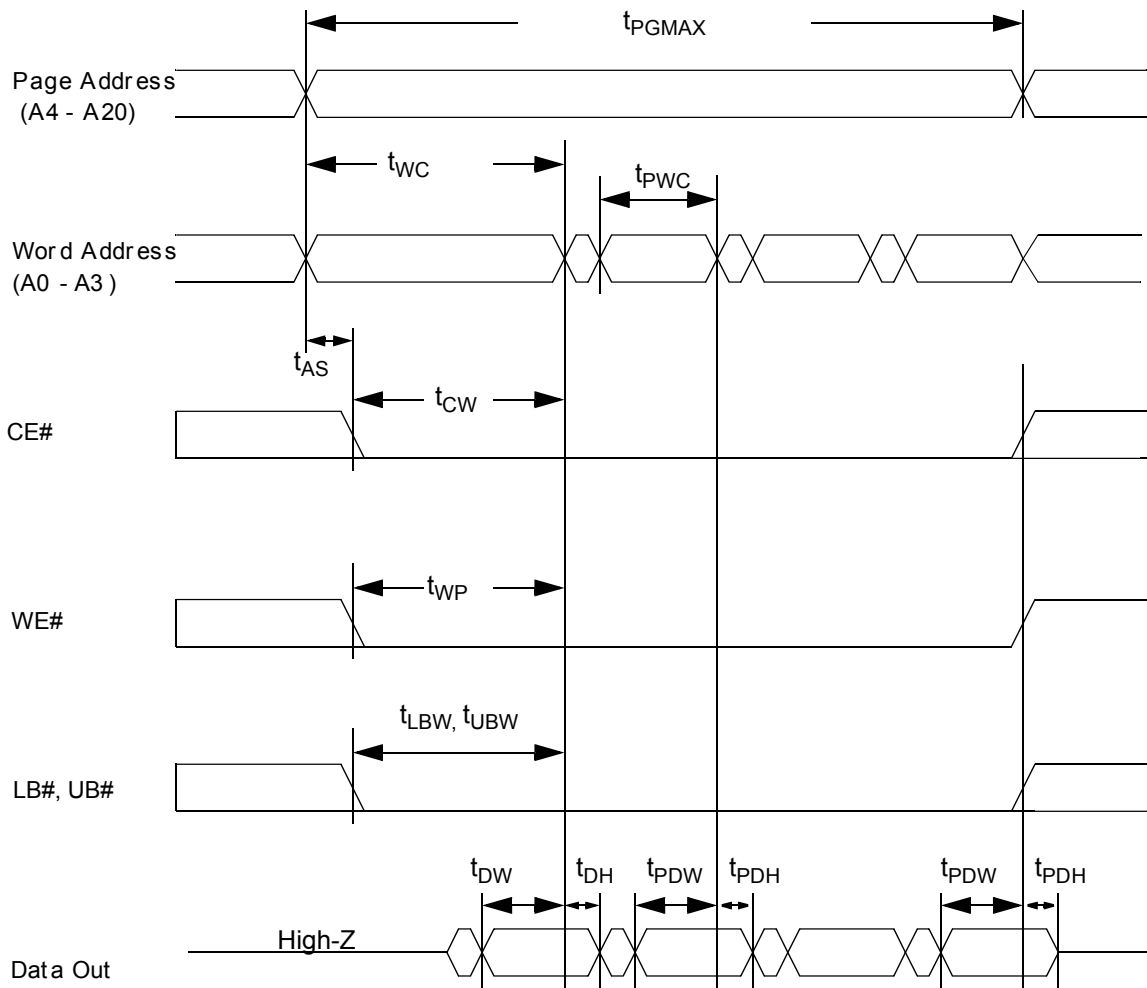

Figure 92. Timing Waveform of Page Mode Write Cycle (ZZ# = V_{IH})

Power Savings Modes (For 16M Page Mode, 32M and 64M Only)

There are several power savings modes.

- Partial Array Self Refresh
- Temperature Compensated Refresh (64M)
- Deep Sleep Mode
- Reduced Memory Size (32M, 16M)

The operation of the power saving modes is controlled by the settings of bits contained in the Mode Register. This definition of the Mode Register is shown in Figure 93 and the various bits are used to enable and disable the various low power modes as well as enabling Page Mode operation. The Mode Register is set by using the timings defined in Figure xxx.

Partial Array Self Refresh (PAR)

In this mode of operation, the internal refresh operation can be restricted to a 16Mb, 32Mb, or 48Mb portion of the array. The array partition to be refreshed is determined by the respective bit settings in the Mode Register. The register settings for the PASR operation are defined in Table xxx. In this PASR mode, when ZZ# is active low, only the portion of the array that is set in the register is refreshed. The data in the remainder of the array will be lost. The PASR operation mode is only available during standby time (ZZ# low) and once ZZ# is returned high, the device resumes full array refresh. All future PASR cycles will use the contents of the Mode Register that has been previously set. To change the address space of the PASR mode, the Mode Register must be reset using the previously defined procedures. For PASR to be activated, the register bit, A4Must be set to a one (1) value, "PASR Enabled". If this is the case, PASR will be activated 10 μ s after ZZ# is brought low. If the A4 register bit is set equal to zero (0), PASR will not be activated.

Temperature Compensated Refresh (for 64Mb)

In this mode of operation, the internal refresh rate can be optimized for the operation temperature used and this can then lower standby current. The DRAM array in the PSRAM must be refreshed internally on a regular basis. At higher temperatures, the DRAM cell must be refreshed more often than at lower temperatures. By setting the temperature of operation in the Mode Register, this refresh rate can be optimized to yield the lowest standby current at the given operating temperature. There are four different temperature settings that can be programmed in to the PSRAM. These are defined in Figure 93.

Deep Sleep Mode

In this mode of operation, the internal refresh is turned off and all data integrity of the array is lost. Deep Sleep is entered by bringing ZZ# low with the A4 register bit set to a zero (0), "Deep Sleep Enabled". If this is the case, Deep Sleep will be entered 10 μ s after ZZ# is brought low. The device will remain in this mode as long as ZZ# remains low. If the A4 register bit is set equal to one (1), Deep Sleep will not be activated.

Reduced Memory Size (for 32M and 16M)

In this mode of operation, the 32Mb PSRAM can be operated as a 8Mb or 16Mb device. The mode and array size are determined by the settings in the VA register. The VA register is set according to the following timings and the bit settings in the table "Address Patterns for RMS". The RMS mode is enabled at the time of ZZ

transitioning high and the mode remains active until the register is updated. To return to the full 32Mb address space, the VA register must be reset using the previously defined procedures. While operating in the RMS mode, the unselected portion of the array may not be used.

Other Mode Register Settings (for 64M)

The Page Mode operation can also be enabled and disabled using the Mode Register. Register bit A7 controls the operation of Page Mode and setting this bit to a one (1), enables Page Mode. If the register bit A7 is set to a zero (0), Page Mode operation is disabled.

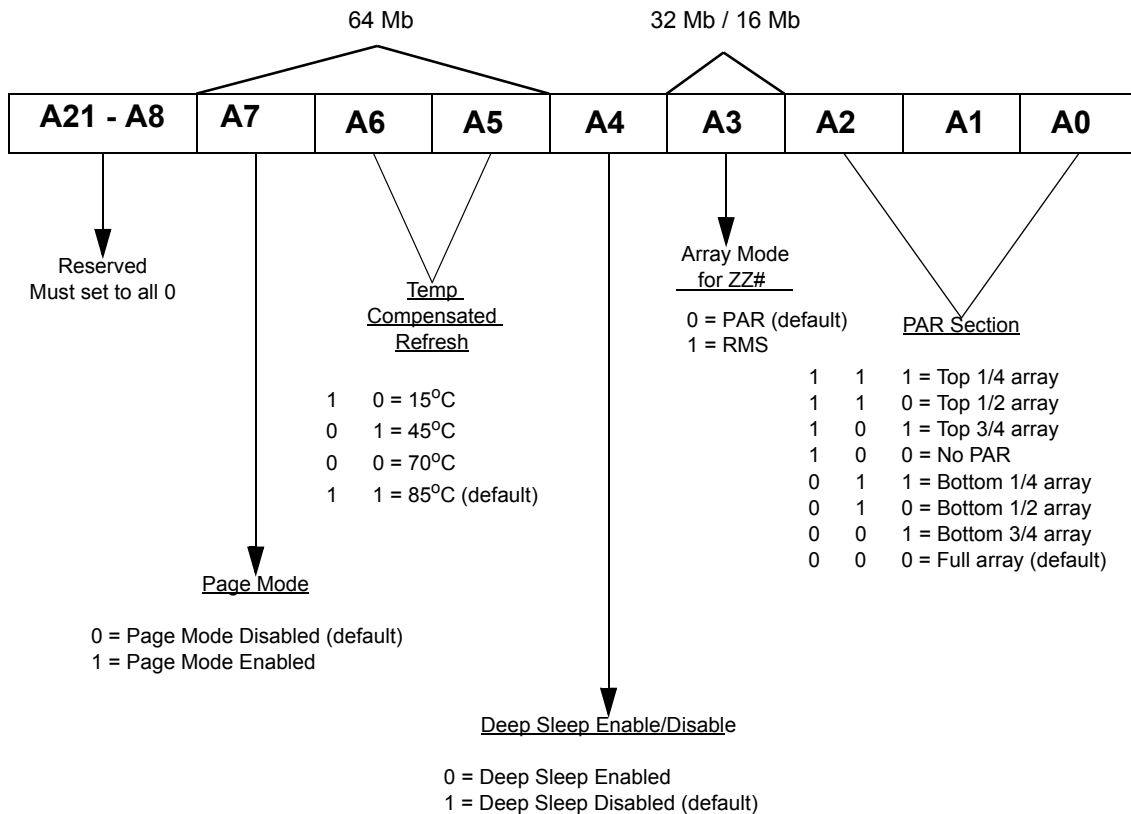

Figure 93. Mode Register

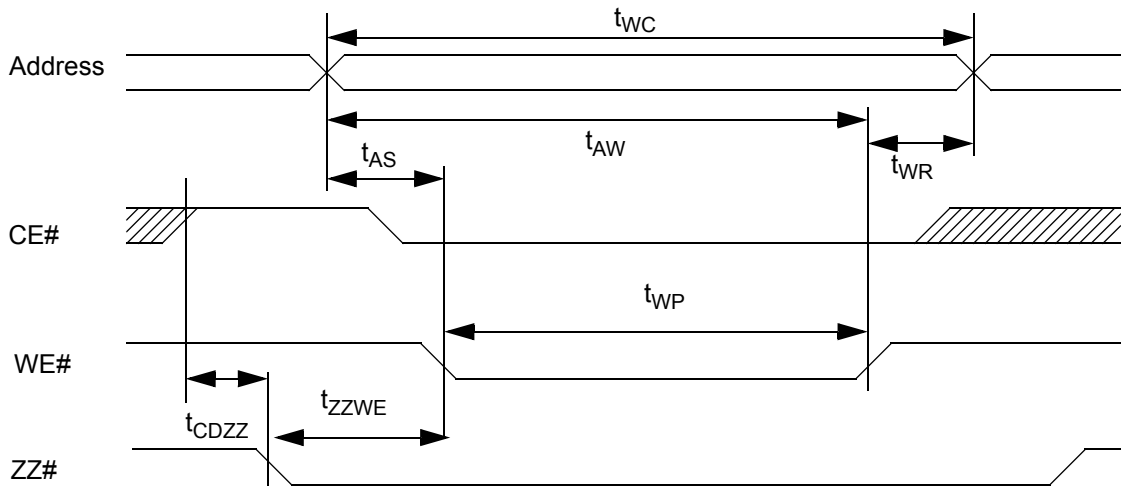

Figure 94. Mode Register Update Timings (UB#, LB#, OE# are Don't Care)

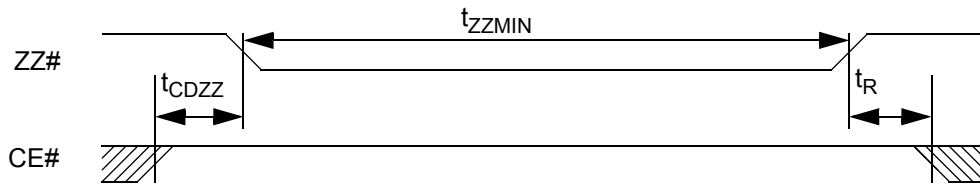

Figure 95. Deep Sleep Mode - Entry/Exit Timings

Mode Register Update and Deep Sleep Timings

Item	Symbol	Min	Max	Unit	Note
Chip deselect to ZZ# low	t_{CDZZ}	5		ns	
ZZ# low to WE# low	t_{ZZWE}	10	500	ns	
Write register cycle time	t_{WC}	70/85		ns	1
Chip enable to end of write	t_{CW}	70/85		ns	1
Address valid to end of write	t_{AW}	70/85		ns	1
Write recovery time	t_{WR}	0		ns	
Address setup time	t_{AS}	0		ns	
Write pulse width	t_{WR}	40		ns	
Deep Sleep Pulse Width	t_{ZZMIN}	10		μ s	
Deep Sleep Recovery	t_R	150		μ s	

Notes:

1. Minimum cycle time for writing register is equal to speed grade of product.

Address Patterns for PASR (A4=I) (64M)

A2	A1	A0	Active Section	Address Space	Size	Density
1	1	1	Top quarter of die	300000h-3FFFFFFh	1Mb x 16	16Mb
1	1	0	Top half of die	200000h-3FFFFFFh	2Mb x 16	32Mb
1	0	1	Reserved			
1	0	0	No PASR	None	0	0
0	1	1	Bottom quarter of die	000000h-0FFFFFFh	1Mb x 16	16Mb
0	1	0	Bottom half of die	000000h-1FFFFFFh	2Mb x 16	32Mb
0	0	1	Reserved			
0	0	0	Full array	000000h-3FFFFFFh	4Mb x 16	64Mb

Deep ICC Characteristics (for 64Mb)

Item	Symbol	Test	Array Partition	Typ	Max	Unit
PASR Mode Standby Current	I _{PASR}	V _{IN} = V _{CC} or 0V, Chip Disabled, t _A = 85°C	None		10	μA
			1/4 Array		75	
			1/2 Array		90	
			Full Array		120	

Item	Symbol	Max Temperature	Typ	Max	Unit
Temperature Compensated Refresh Current	I _{TCR}	15°C		50	μA
		45°C		60	
		70°C		80	
		85°C		120	

Item	Symbol	Test	Typ	Max	Unit
Deep Sleep Current	I _{ZZ}	V _{IN} = V _{CC} or 0V, Chip in ZZ# mode, t _A = 25°C		10	μA

Address Patterns for PAR (A3= 0, A4=I) (32M)

A2	A1	A0	Active Section	Address Space	Size	Density
0	1	1	One-quarter of die	000000h - 07FFFFh	512Kb x 16	8Mb
0	1	0	One-half of die	000000h - 0FFFFFFh	1Mb x 16	16Mb
x	0	0	Full die	000000h - 1FFFFFFh	2Mb x 16	32Mb
1	1	1	One-quarter of die	180000h - 1FFFFFFh	512Kb x 16	8Mb
1	1	0	One-half of die	100000h - 1FFFFFFh	1Mb x 16	16Mb

Address Patterns for RMS (A3 = I, A4 = I) (32M)

A2	A1	A0	Active Section	Address Space	Size	Density
0	1	1	One-quarter of die	000000h - 07FFFFh	512Kb x 16	8Mb
0	1	0	One-half of die	000000h - 0FFFFFFh	1Mb x 16	16Mb
1	1	1	One-quarter of die	180000h - 1FFFFFFh	512Kb x 16	8Mb
1	1	0	One-half of die	100000h - 1FFFFFFh	1Mb x 16	16Mb

Low Power ICC Characteristics (32M)

Item	Symbol	Test	Array Partition	Typ	Max	Unit
PAR Mode Standby Current	I_{PAR}	$V_{IN} = V_{CC}$ or 0V, Chip Disabled, $t_A = 85^\circ\text{C}$	1/4 Array		65	μA
			1/2 Array		80	
RMS Mode Standby Current	I_{RMSSB}	$V_{IN} = V_{CC}$ or 0V, Chip Disabled, $t_A = 85^\circ\text{C}$	4Mb Device		40	μA
			8Mb Device		50	
Deep Sleep Current	I_{ZZ}	$V_{IN} = V_{CC}$ or 0V, Chip in ZZ mode, $t_A = 85^\circ\text{C}$			10	μA

Address Patterns for PAR (A3= 0, A4=1) (16M)

A2	A1	A0	Active Section	Address Space	Size	Density
0	1	1	One-quarter of die	00000h - 0FFFFh	256Kb x 16	4Mb
0	1	0	One-half of die	00000h - 7FFFFh	512Kb x 16	8Mb
x	0	0	Full die	00000h - FFFFFh	1Mb x 16	162Mb
1	1	1	One-quarter of die	C0000h - FFFFh	256Kb x 16	4Mb
1	1	0	One-half of die	80000h - 1FFFFh	512Kb x 16	8Mb

Address Patterns for RMS (A3 = 1, A4 = 1) (16M)

A2	A1	A0	Active Section	Address Space	Size	Density
0	1	1	One-quarter of die	00000h - 0FFFFh	256Kb x 16	4Mb
0	1	0	One-half of die	00000h - 7FFFFh	512Kb x 16	8Mb
1	1	1	One-quarter of die	C0000h - FFFFh	256Kb x 16	4Mb
1	1	0	One-half of die	80000h - FFFFFh	512Kb x 16	8Mb

Low Power ICC Characteristics (16M)

Item	Symbol	Test	Array Partition	Typ	Max	Unit
PAR Mode Standby Current	I_{PAR}	$V_{IN} = V_{CC}$ or 0V, Chip Disabled, $t_A = 85^\circ\text{C}$	1/4 Array		65	μA
			1/2 Array		80	
RMS Mode Standby Current	I_{RMSSB}	$V_{IN} = V_{CC}$ or 0V, Chip Disabled, $t_A = 85^\circ\text{C}$	4Mb Device		40	μA
			8Mb Device		50	
Deep Sleep Current	I_{ZZ}	$V_{IN} = V_{CC}$ or 0V, Chip in ZZ# mode, $t_A = 85^\circ\text{C}$			10	μA

Revision Summary

Revision A (May 3, 2004)

Initial release.

Revision A1 (May 6, 2004)

MCP Features

Corrected the high performance access times.

Connection Diagrams

Added reference points on all diagrams.

Ordering Information

Corrected package types.

Corrected the description of product family to Page Mode Flash memory.

pSRAM Type 1

Corrected the description of the 8Mb device to 512Kb Word x 16-bit.

pSRAM Type 6

Corrected the description of the 2Mb device to 128Kb Word x 16-bit.

Corrected the description of the 4Mb device to 256Kb Word x 16-bit.

Revision A2 (May 11, 2004)

General Description

Corrected the tables to reflect accurate device configurations.

Revision A3 (June 16, 2004)

Ordering Information

Corrected the Valid Combinations tables to reflect accurate device configurations.

SRAM

New section added.

Revision A4 (July 16, 2004)

Global Changes

Global Change of FASL to Spansion.

Global change to remove space between M and Mb callouts.

“32Mb Flash Memory” on page 2

Replaced “S71PL032J08-07” with “S71PL032J08-0B”.

Replaced “S71PL032JA0” with “S71PL032JA0-07”.

Added row with the following content: S71PL032JA0-08; 65; 16Mb pSRAM; 70; pSRAM3; TLC056.

“64Mb Flash Memory” on page 2

Replaced “S71PL064J08-0K” with “S71PL064J08-0B”.

Replaced “S71PL064J08-0P” with “S71PL064J08-0U”.

Deleted “S71PL064J80-05” row.

Replaced “S71PL064JA0-07” with “S71PL064JA0-0K”.

Replaced "S71PL064JA0-0Z" with

Added row with the following content: S71PL064JB0-07; 65; 32M pSRAM; 70; Ppsram1; TLC056.

"32Mb Flash Memory" on page 2

Replaced "S71PL032JA0-08" with "S71PL032JA0-0F".

"64Mb Flash Memory" on page 2

Replaced "S71PL032JA0-07" with "S71PL032JA0-0K".

"128Mb Flash Memory" on page 3

Added row with the following content: S71PL127JB0-9; 65; 32M pSRAM; 70; pSRAM; TLA064.

Replaced "S71PL127JB0-97" with "S71PL127JB0-9Z".

Added row with the following content: S71PL127JC0-97; 65; 64M pSRAM; 70; pSRAM1; TLA064.

Replaced "S71PL127JC0-9P" with "S71PL127JC0-9Z".

In the S71PL254JB0-TB row changed pSRAM type from "pSRAM3" to "pSRAM2".

"256Mb Flash Memory (2xS29PL127J)" on page 3

Added row with the following content: S71PL254JB0-TB; 65; 32M pSRAM; 70; pSRAM3; FTA084.

Added row with the following content: S71PL254JC0-TB; 65; 64M pSRAM; 70; pSRAM2; FTA084.

"Connection Diagram (S7IPL127J)" on page 11

Updated pins D8, D9, and L5.

Added notes 2 and 3 to drawing.

"Connection Diagram (S7IPL254J)" on page 12

Updated pins D8 and D9.

Added Note 2 to drawing.

"S7IPL032J Valid Combinations" on page 15

Changed S71PL032J08 (p)SRAM Type Access Time (ns) from "SRAM1" to "SRAM2" (4 changes made in table).

Changed S71PL032JA0 (p)SRAM Type Access Time (ns) from "SRAM3 / 70" to "pSRAM3 / 70".

Deleted all cells with the following collaborated text: "BAW,BFW, BAI. BFI".
Merged previous place holder with cell above.

"S7IPL064J Valid Combinations" on page 16

In (p)SRAM Type/Access Time (ns) changed all instances of "stet" to "pSRAM1/70".

In Package Modifier/Model Number changed all instances of "stet" to "07".

Added row to BAW Package and Temperature sections with the following content: S71PL064JB0; 07; 65 (previously inclusive); pSRAM1/70.

"S7IPL127J Valid Combinations" on page 17

Changed the S71PL127JA0 Package Modifier/Model Number from "9Z" to "9P" (4 instances).

Added 4 rows with the following content: S71PL127JC0; 97; pSRAM1/70.

“S71PL254J Valid Combinations” on page I8

Added 4 rows with the following content: S71PL254JC0; TB; pSRAM2/70.

Added 4 rows with the following content: S71PL254JB0; TB; pSRAM2/70.

“S71PL254/I27/064/032J based MCPs” on page I

Added 254M to Megabit indicator.

Added 16 to CMOS indicator.

Revision A5 (September 14, 2004)

Product Selector Guide

Updated the 128Mb Flash Memory table.

Valid Combinations Table

Updated the S71PL127J Valid Combinations table.

Revision A6 (November 22, 2004)

Product Selector Guide

Updated the 32Mb and 64Mb tables.

Valid Combinations Tables

Updated the 32Mb and 64Mb combinations.

Physical Dimensions

Added the TSB064 package.

Colophon

The products described in this document are designed, developed and manufactured as contemplated for general use, including without limitation, ordinary industrial use, general office use, personal use, and household use, but are not designed, developed and manufactured as contemplated (I) for any use that includes fatal risks or dangers that, unless extremely high safety is secured, could have a serious effect to the public, and could lead directly to death, personal injury, severe physical damage or other loss (i.e., nuclear reaction control in nuclear facility, aircraft flight control, air traffic control, mass transport control, medical life support system, missile launch control in weapon system), or (2) for any use where chance of failure is intolerable (i.e., submersible repeater and artificial satellite). Please note that Spansion will not be liable to you and/or any third party for any claims or damages arising in connection with above-mentioned uses of the products. Any semiconductor devices have an inherent chance of failure. You must protect against injury, damage or loss from such failures by incorporating safety design measures into your facility and equipment such as redundancy, fire protection, and prevention of over-current levels and other abnormal operating conditions. If any products described in this document represent goods or technologies subject to certain restrictions on export under the Foreign Exchange and Foreign Trade Law of Japan, the US Export Administration Regulations or the applicable laws of any other country, the prior authorization by the respective government entity will be required for export of those products.

Trademarks and Notice

The contents of this document are subject to change without notice. This document may contain information on a Spansion product under development by Spansion LLC. Spansion LLC reserves the right to change or discontinue work on any product without notice. The information in this document is provided as is without warranty or guarantee of any kind as to its accuracy, completeness, operability, fitness for particular purpose, merchantability, non-infringement of third-party rights, or any other warranty, express, implied, or statutory. Spansion LLC assumes no liability for any damages of any kind arising out of the use of the information in this document.

Copyright © 2004 Spansion LLC. All rights reserved. Spansion, the Spansion logo, MirrorBit, combinations thereof, and ExpressFlash are trademarks of Spansion LLC. Other company and product names used in this publication are for identification purposes only and may be trademarks of their respective companies.

Copyright © Each Manufacturing Company.

All Datasheets cannot be modified without permission.

This datasheet has been download from :

www.AllDataSheet.com

100% Free DataSheet Search Site.

Free Download.

No Register.

Fast Search System.

www.AllDataSheet.com