



25LC080/160

8K/16K 2.5V SPI™ Bus Serial EEPROM

FEATURES

- SPI modes 0,0 and 1,1
- 3 MHz Clock Rate
- Single supply with programming operation down to 2.5V
- Low Power CMOS Technology
 - Max Write Current: 5 mA
 - Read Current: 1.0 mA
 - Standby Current: 1 μ A typical
- Organization
 - 1024 x 8 for 25LC080
 - 2048 x 8 for 25LC160
- 16 Byte Page
- Sequential Read
- Self-timed ERASE and WRITE Cycles
- Block Write Protection
 - Protect none, 1/4, 1/2, or all of Array
- Built-in Write Protection
 - Power On/Off Data Protection Circuitry
 - Write Latch
 - Write Protect Pin
- High Reliability
 - Endurance: 10M cycles (guaranteed)
 - Data Retention: >200 years
 - ESD protection: >4000 V
- 8-pin PDIP/SOIC Packages
- Temperature ranges supported
 - Commercial (C): 0°C to +70°C
 - Industrial (I): -40°C to +85°C

DESCRIPTION

The Microchip Technology Inc. 25LC080/160 are 8K and 16K bit Serial Electrically Erasable PROMs. The memory is accessed via a simple Serial Peripheral Interface (SPI) compatible serial bus. The bus signals required are a clock input (SCK) plus separate data in (SI) and data out (SO) lines. Access to the device is controlled through a chip select (\overline{CS}) input, allowing any number of devices to share the same bus.

There are two other inputs that provide the end user with additional flexibility. Communication to the device can be paused via the hold pin (HOLD). While the device is paused, transitions on its inputs will be ignored, with the exception of chip select, allowing the host to service higher priority interrupts. Also, write operations to the Status Register can be disabled via the write protect pin (\overline{WP}).

PACKAGE TYPES

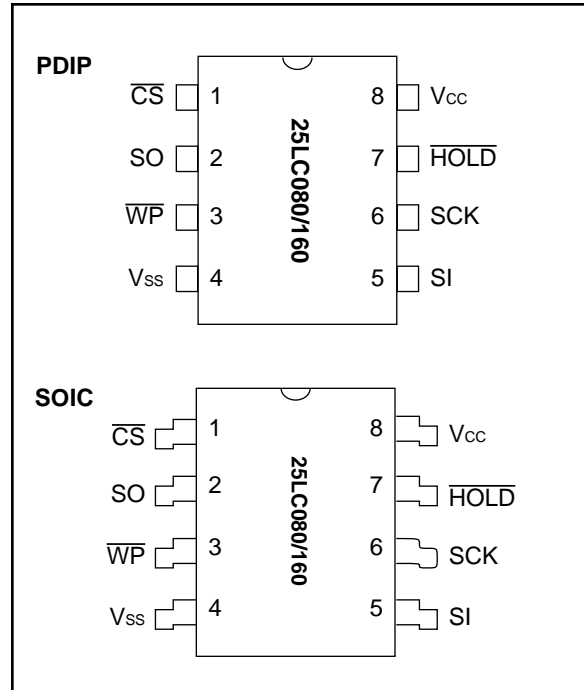

BLOCK DIAGRAM

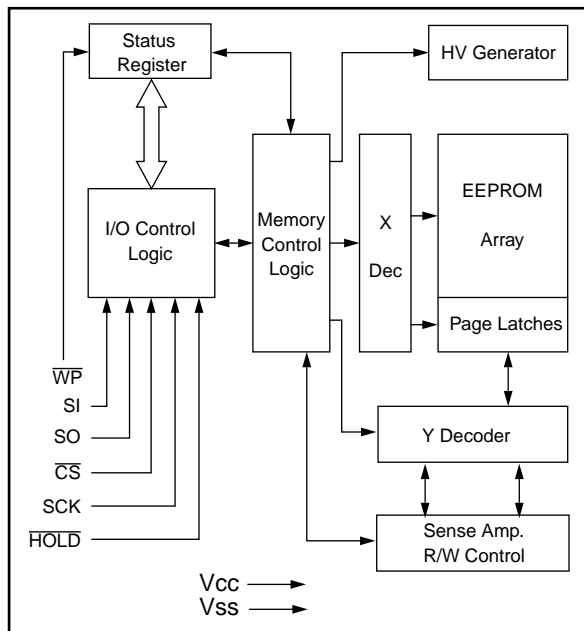

SPI is a trademark of Motorola.

25LC080/160

1.0 ELECTRICAL CHARACTERISTICS

1.1 Maximum Ratings*

V_{CC}..... 7.0V
 All inputs and outputs w.r.t. V_{SS}..... -0.6V to V_{CC} +1.0V
 Storage temperature -65°C to 150°C
 Ambient temperature under bias..... -65°C to 125°C
 Soldering temperature of leads (10 seconds) ...+300°C
 ESD protection on all pins..... 4kV

*Notice: Stresses above those listed under 'Maximum ratings' may cause permanent damage to the device. This is a stress rating only and functional operation of the device at those or any other conditions above those indicated in the operational listings of this specification is not implied. Exposure to maximum rating conditions for extended period of time may affect device reliability

TABLE 1-1: PIN FUNCTION TABLE

Name	Function
\overline{CS}	Chip Select Input
SO	Serial Data Output
SI	Serial Data Input
SCK	Serial Clock Input
\overline{WP}	Write Protect Pin
V _{SS}	Ground
V _{CC}	Supply Voltage
HOLD	Hold Input

TABLE 1-2: DC CHARACTERISTICS

Applicable over recommended operating ranges shown below unless otherwise noted.
 V_{CC} = +2.5V to +5.5V
 Commercial (C): T_{amb} = 0°C to +70°C
 Industrial (I): T_{amb} = -40°C to +85°C

Parameter	Symbol	Min	Max	Units	Test Conditions
High level input voltage	V _{IH1}	2.0	V _{CC} +1	V	V _{CC} ≥ 2.7V
	V _{IH2}	0.7 V _{CC}	V _{CC} +1	V	V _{CC} < 2.7V
Low level input voltage	V _{IL1}	-0.3	0.8	V	V _{CC} ≥ 2.7V
	V _{IL2}	-0.3	0.3 V _{CC}	V	V _{CC} < 2.7V
Low level output voltage	V _{OL}	—	0.4	V	I _{OL} =2.1 mA
High level output voltage	V _{OH}	V _{CC} -0.5	—	V	I _{OH} =-400 μA
Input leakage current	I _{LI}	-10	10	μA	\overline{CS} =V _{IH} , V _{IN} =V _{SS} to V _{CC}
Output leakage current	I _{LO}	-10	10	μA	\overline{CS} =V _{IH} , V _{OUT} =V _{SS} to V _{CC}
Internal Capacitance (all inputs and outputs)	C _{INT}	—	7	pF	T _{amb} =25°C, F _{CLK} =3.0 MHz, V _{CC} =5.5V (Note)
Operating Current	I _{CC WRITE}	—	5	mA	V _{CC} =5.5V
		—	3	mA	V _{CC} =2.5V
	I _{CC READ}	—	1	mA	V _{CC} =5.5V; 3 MHz
		—	500	μA	V _{CC} =2.5V; 2 MHz
Standby Current	I _{CCS}	—	5	μA	\overline{CS} =V _{CC} =5.5V; V _{in} =0V or V _{CC}
		—	2	μA	\overline{CS} =V _{CC} =2.5V; V _{in} =0V or V _{CC}

Note: This parameter is periodically sampled and not 100% tested.

FIGURE 1-1: AC TEST CIRCUIT

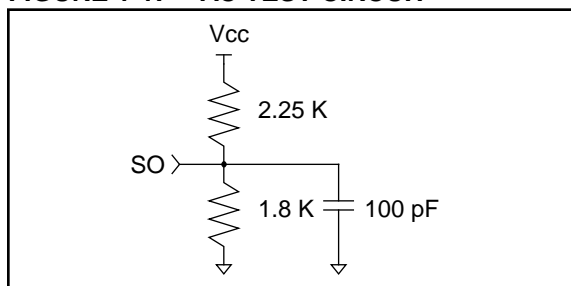

1.2 AC Test Conditions

AC Waveform:

V_{LO} = 0.2V

V_{HI} = V_{CC} - 0.2V (Note 1)

V_{HI} = 4.0V (Note 2)

Timing Measurement Reference Level

Input 0.5 V_{CC}

Output 0.5 V_{CC}

Note 1: For V_{CC} ≤ 4.0V

2: For V_{CC} > 4.0V

FIGURE 1-2: SERIAL INPUT TIMING

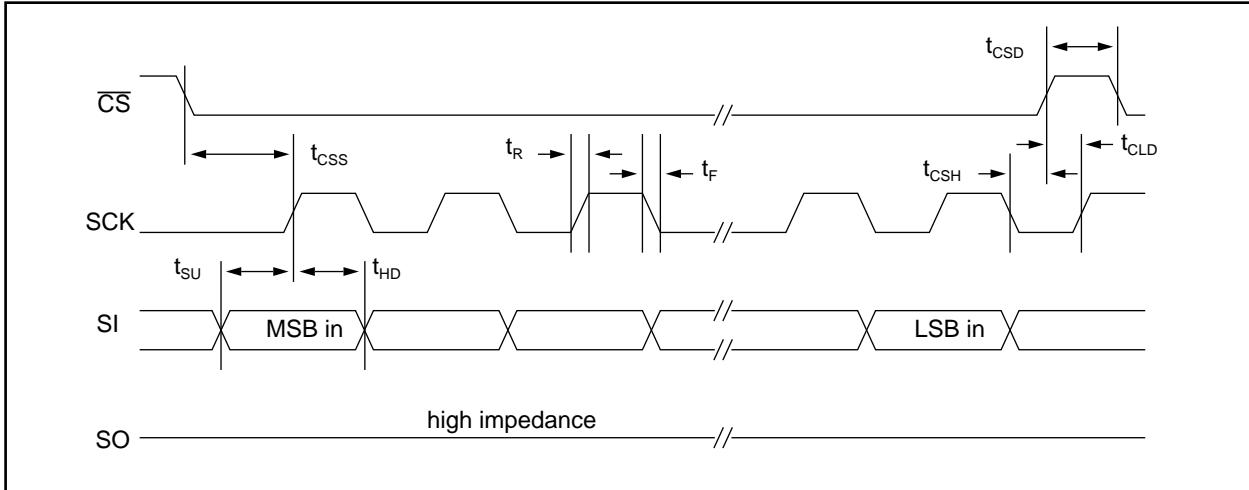

FIGURE 1-3: SERIAL OUTPUT TIMING

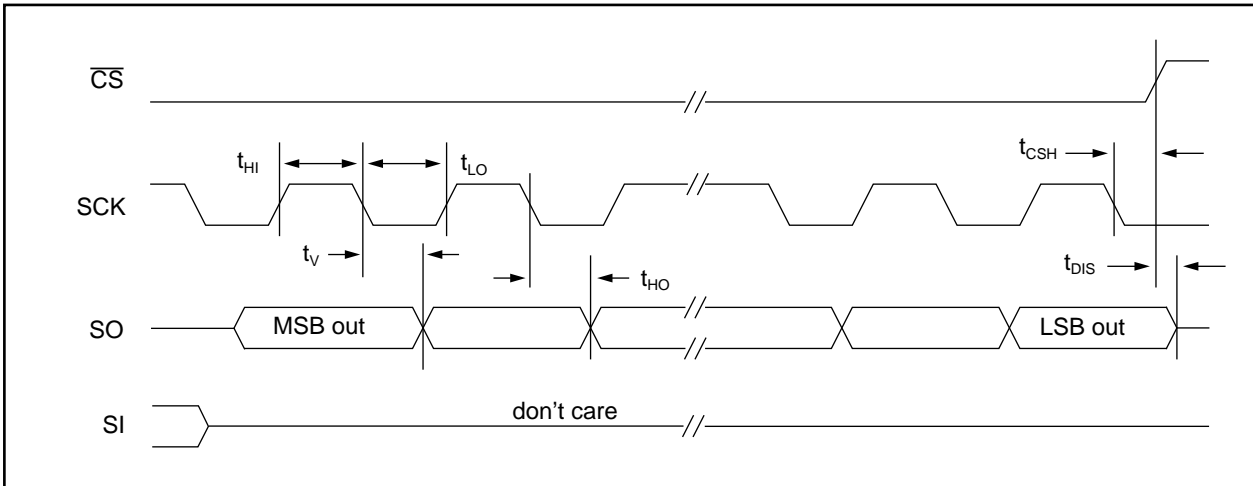
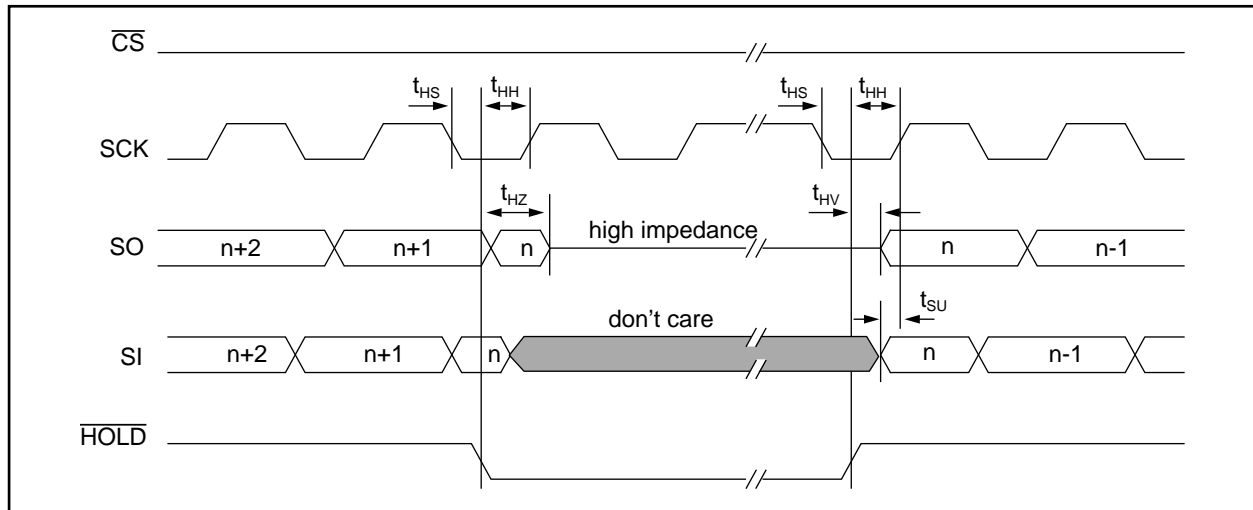

FIGURE 1-4: HOLD TIMING



25LC080/160

TABLE 1-3: AC CHARACTERISTICS

Applicable over recommended operating ranges shown below unless otherwise noted. Vcc = +2.5V to +5.5V Commercial (C): Tamb = 0°C to +70°C Industrial (I): Tamb = -40°C to +85°C					
Symbol	Parameter	Min	Max	Units	Test Conditions
fSCK	Clock Frequency	—	3	MHz	Vcc=4.5V to 5.5V
		—	2	MHz	Vcc=2.5V to 4.5V
tCSS	CS Setup Time	100	—	ns	Vcc=4.5V to 5.5V
		250	—	ns	Vcc=2.5V to 4.5V
tCSH	CS Hold Time	100	—	ns	Vcc=4.5V to 5.5V
		250	—	ns	Vcc=2.5V to 4.5V
tCSD	CS Disable Time	250	—	ns	Vcc=4.5V to 5.5V
		500	—	ns	Vcc=2.5V to 4.5V
tSU	Data Setup Time	30	—	ns	Vcc=4.5V to 5.5V
		50	—	ns	Vcc=2.5V to 4.5V
tHD	Data Hold Time	50	—	ns	Vcc=4.5V to 5.5V
		100	—	ns	Vcc=2.5V to 4.5V
tR	CLK Rise Time	—	2	µs	(Note 1)
tF	CLK Fall Time	—	2	µs	(Note 1)
tHI	Clock High Time	150	—	ns	Vcc=4.5V to 5.5V
		250	—	ns	Vcc=2.5V to 4.5V
tLO	Clock Low Time	150	—	ns	Vcc=4.5V to 5.5V
		250	—	ns	Vcc=2.5V to 4.5V
tCLD	Clock Delay Time	50	—	ns	
tV	Output Valid from Clock Low	—	150	ns	Vcc=4.5V to 5.5V
		—	250	ns	Vcc=2.5V to 4.5V
tHO	Output Hold Time	0	—	ns	
tDIS	Output Disable Time	—	200	ns	Vcc=4.5V to 5.5V (Note 1)
		—	250	ns	Vcc=2.5V to 4.5V (Note 1)
tHS	HOLD Setup Time	100	—	ns	Vcc=4.5V to 5.5V
		100	—	ns	Vcc=2.5V to 4.5V
tHH	HOLD Hold Time	100	—	ns	Vcc=4.5V to 5.5V
		100	—	ns	Vcc=2.5V to 4.5V
tHZ	HOLD Low to Output High-Z	100	—	ns	Vcc=4.5V to 5.5V (Note 1)
		150	—	ns	Vcc=2.5V to 4.5V (Note 1)
tHV	HOLD High to Output Valid	100	—	ns	Vcc=4.5V to 5.5V (Note 1)
		150	—	ns	Vcc=2.5V to 4.5V (Note 1)
tWC	Internal Write Cycle Time	—	5	ms	(Note 2)
—	Endurance	10M	—	E/W Cycles	25°C, Vcc = 5.0V, Block Mode (Note 3)

Note 1: This parameter is periodically sampled and not 100% tested.

2: tWC begins on the rising edge of CS after a valid write sequence and ends when the internal self-timed write cycle is complete.

3: This parameter is not tested but guaranteed by characterization. For endurance estimates in a specific application, please consult the Total Endurance Model which can be obtained on our BBS or website.

2.0 PRINCIPLES OF OPERATION

The 25LC080/160 is an 1024/2048 byte EEPROM designed to interface directly with the Serial Peripheral Interface (SPI) port of many of today's popular microcontroller families, including Microchip's midrange PIC16CXX microcontrollers. It may also interface with microcontrollers that do not have a built-in SPI port by using discrete I/O lines programmed properly with software.

The 25LC080/160 contains an 8-bit instruction register. The part is accessed via the SI pin, with data being clocked in on the rising edge of SCK. If the WPEN bit in the status register is set, the \overline{WP} pin must be held high to allow writing to the non-volatile bits in the status register.

Table 2-1 contains a list of the possible instruction bytes and format for device operation. All instructions, addresses and data are transferred MSB first, LSB last.

Data is sampled on the first rising edge of SCK after \overline{CS} goes low. If the clock line is shared with other peripheral devices on the SPI bus, the user can assert the \overline{HOLD} input and place the 25LC080/160 in 'HOLD' mode. After releasing the \overline{HOLD} pin, operation will resume from the point when the \overline{HOLD} was asserted.

2.1 Write Enable (WREN) and Write Disable (WRDI)

The 25LC080/160 contains a write enable latch. This latch must be set before any write operation will be completed internally. The WREN instruction will set the latch, and the WRDI will reset the latch. The following is a list of conditions under which the write enable latch will be reset:

- Power-up
- WRDI instruction successfully executed
- WRSR instruction successfully executed
- WRITE instruction successfully executed

2.2 Read Status Register (RDSR)

The RDSR instruction provides access to the status register. The status register may be read at any time, even during a write cycle. The status register is formatted as follows:

7	6	5	4	3	2	1	0
WPEN	X	X	X	BP1	BP0	WEL	WIP

The **Write-In-Process (WIP)** bit indicates whether the 25LC080/160 is busy with a write operation. When set to a '1' a write is in progress, when set to a '0' no write is in progress. This bit is read only.

The **Write Enable Latch (WEL)** bit indicates the status of the write enable latch. When set to a '1' the latch allows writes to the array and status register, when set to a '0' the latch prohibits writes to the array and status register. The state of this bit can always be updated via

the WREN or WRDI commands regardless of the state of write protection on the status register. This bit is read only.

The **Block Protection (BP0 and BP1)** bits indicate which blocks are currently write protected. These bits are set by the user issuing the WRSR instruction. These bits are non-volatile.

The **Write Protect Enable (WPEN)** bit is a non-volatile bit that is available as an enable bit for the \overline{WP} pin. The Write Protect (\overline{WP}) pin and the Write Protect Enable (WPEN) bit in the status register control the programmable hardware write protect feature. Hardware write protection is enabled when \overline{WP} pin is low and the WPEN bit is high. Hardware write protection is disabled when either the \overline{WP} pin is high or the WPEN bit is low. When the chip is hardware write protected, only writes to non-volatile bits in the status register are disabled. See Table 2-2 for matrix of functionality on the WPEN bit and Figure 2-1 for a flowchart of Table 2-2.

See Figure 3-5 for RDSR timing sequence.

TABLE 2-1: INSTRUCTION SET

Instruction Name	Instruction Format	Description
WREN	0000 0110	Set the write enable latch (enable write operations)
WRDI	0000 0100	Reset the write enable latch (disable write operations)
RDSR	0000 0101	Read status register
WRSR	0000 0001	Write status register (write protect enable and block write protection bits)
READ	0000 0011	Read data from memory array beginning at selected address
WRITE	0000 0010	Write data to memory array beginning at selected address

TABLE 2-2: WRITE PROTECT FUNCTIONALITY MATRIX

WPEN	WP	WEL	Protected Blocks	Unprotected Blocks	Status Register
0	X	0	Protected	Protected	Protected
0	X	1	Protected	Writable	Writable
1	Low	0	Protected	Protected	Protected
1	Low	1	Protected	Writable	Protected
X	High	0	Protected	Protected	Protected
X	High	1	Protected	Writable	Writable

FIGURE 2-1: WRITE TO STATUS REGISTER AND/OR ARRAY FLOWCHART

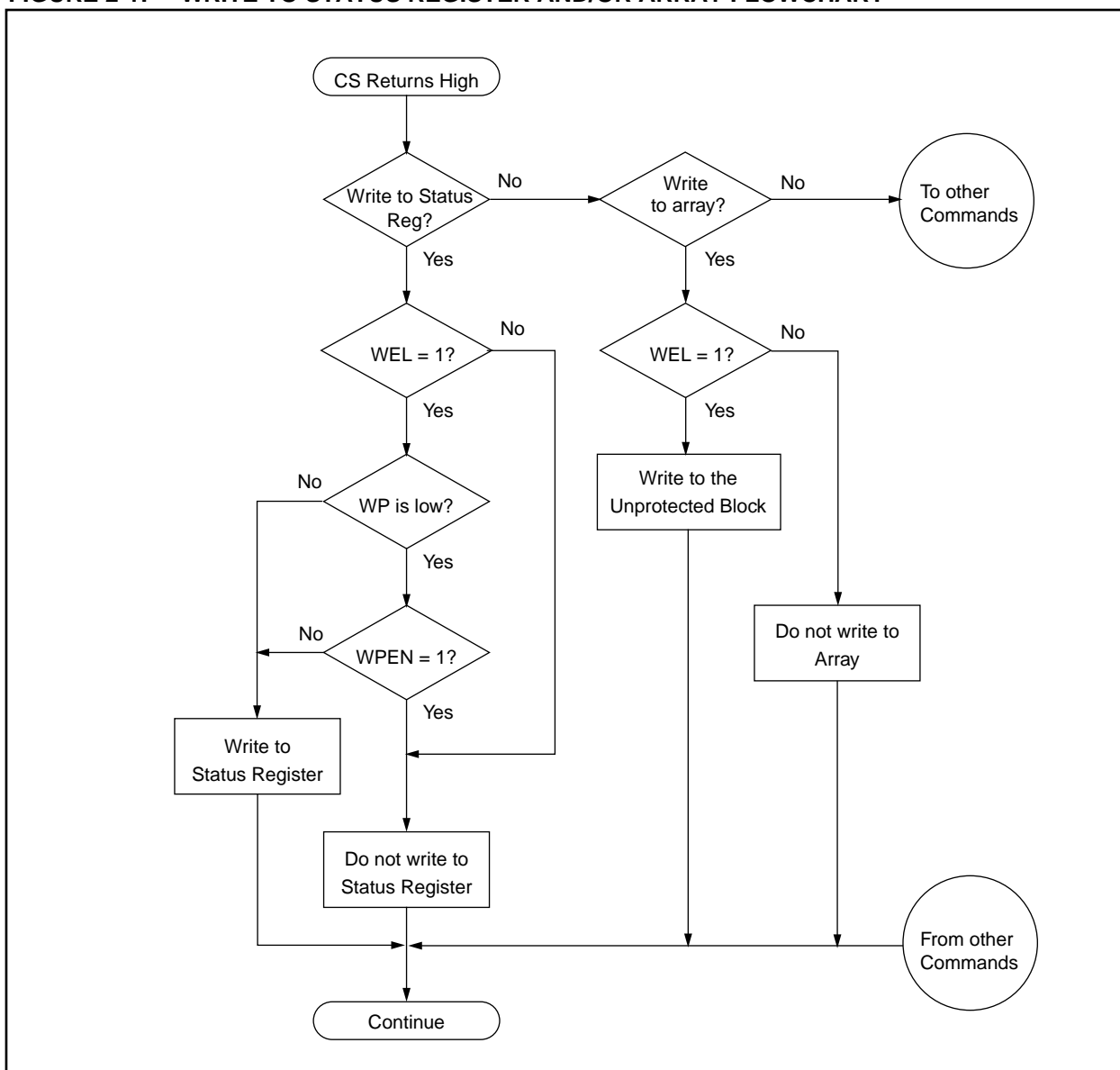

2.3 Write Status Register (WRSR)

The WRSR instruction allows the user to select one of four protection options for the array by writing to the appropriate bits in the status register. The array is divided up into four segments. The user has the ability to write protect none, one, two, or all four of the segments of the array. The partitioning is controlled as illustrated in table below.

See Figure for WRSR timing sequence.

TABLE 2-3: ARRAY PROTECTION

BP1	BP0	Array Addresses Write Protected
0	0	none
0	1	upper 1/4 300h-3FFh for 25LC080 600h-7FFh for 25LC160
1	0	upper 1/2 200h-3FFh for 25LC080 400h-7FFh for 25LC160
1	1	all 000h-3FFh for 25LC080 000h-7FFh for 25LC160

3.0 DEVICE OPERATION

3.1 Clock and Data Timing

Data input on the SI pin is latched on the rising edge of SCK. Data is output on the SO pin after the falling edge of SCK.

3.2 Read Sequence

The part is selected by pulling \overline{CS} low. The 8-bit read instruction is transmitted to the 25LC080/160 followed by the 16-bit address, with the five (25LC160) or six (25LC080) MSBs of the address being don't care bits. After the correct read instruction and address are sent, the data stored in the memory at the selected address is shifted out on the SO pin. The data stored in the memory at the next address can be read sequentially by continuing to provide clock pulses. The internal address pointer is automatically incremented to the next higher address after each byte of data is shifted out. When the highest address is reached (\$3FF for 25LC080, \$7FF for 25LC160) the address counter rolls over to address \$000 allowing the read cycle to be continued indefinitely. The read operation is terminated by setting \overline{CS} high (see Figure 3-1).

3.3 Write Sequence

Prior to any attempt to write data to the 25LC080/160, the write enable latch must be set by issuing the WREN instruction (Figure 3-2). This is done by setting \overline{CS} low and then clocking the proper instruction into the 25LC080/160. After all eight bits of the instruction are transmitted, the \overline{CS} must be brought high to set the

write enable latch. If the write operation is initiated immediately after the WREN instruction without \overline{CS} being brought high, the data will not be written to the array because the write enable latch will not have been properly set.

Once the write enable latch is set, the user may proceed by setting the \overline{CS} low, issuing a write instruction, followed by the 16-bit address, with the five (25LC160) or six (25LC080) MSBs of the address being don't care bits, and then the data to be written. Up to 16 bytes of data can be sent to the 25LC080/160 before a write cycle is necessary. The only restriction is that all of the bytes must reside in the same page. A page address begins with XXXX XXXX XXXX 0000 and ends with XXXX XXXX XXXX 1111. If the internal address counter reaches XXXX XXXX XXXX 1111 and the clock continues, the counter will roll back to the first address of the page and overwrite any data in the page that may have been written.

For the data to be actually written to the array, the \overline{CS} must be brought high after the least significant bit (D0) of the nth data byte has been clocked in. If \overline{CS} is brought high at any other time, the write operation will not be completed. Refer to Figure 3-3 and Figure 3-4 for more detailed illustrations on the byte write sequence and the page write sequence, respectively.

While the write is in progress, the status register may be read to check the status of the WPEN, WIP, WEL, BP1, and BP0 bits. A read attempt of a memory array location will not be possible during a write cycle. When a write cycle is completed, the write enable latch is reset

3.4 Data Protection

The following protection has been implemented to prevent inadvertent writes to the array:

- The write enable latch is reset on power-up.
- A write enable instruction must be issued to set the write enable latch.
- After a successful byte write, page write, or status register write, the write enable latch is reset.
- \overline{CS} must be set high after the proper number of clock cycles to start an internal write cycle.
- Access to the array during an internal write cycle is ignored and programming is continued.

3.5 Power On State

The 25LC080/160 powers on in the following state:

- The device is in low power standby mode ($CS=1$).
- The write enable latch is reset.
- SO is in high impedance state.
- A low level on \overline{CS} is required to enter active state.

25LC080/160

FIGURE 3-1: READ SEQUENCE

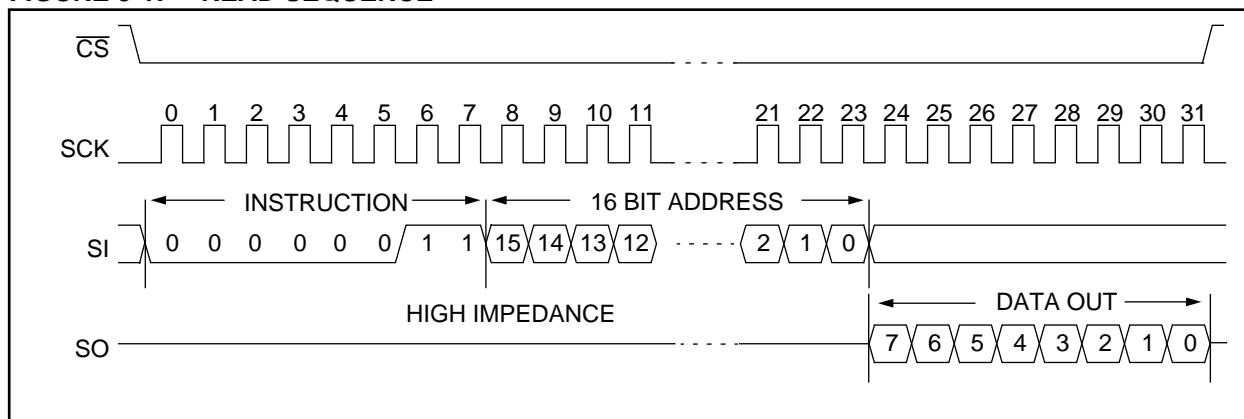

FIGURE 3-2: WRITE ENABLE SEQUENCE

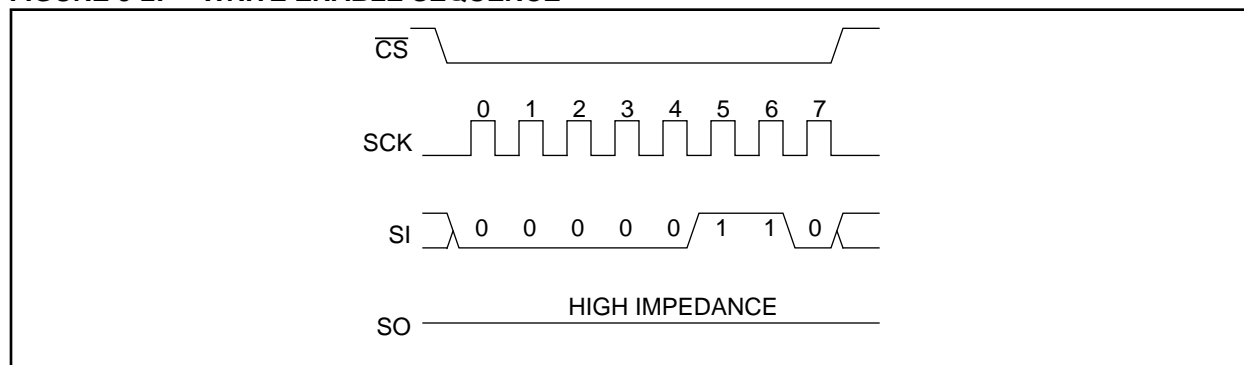

FIGURE 3-3: WRITE SEQUENCE

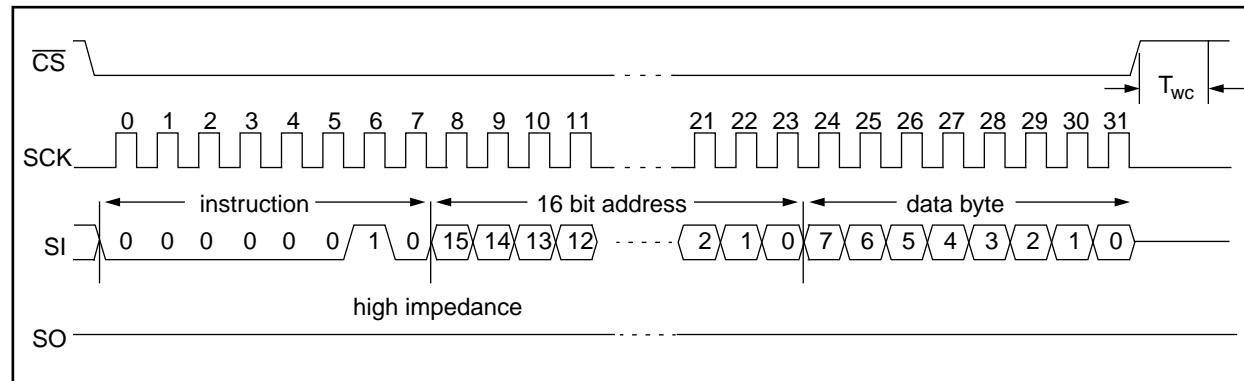

FIGURE 3-4: PAGE WRITE SEQUENCE

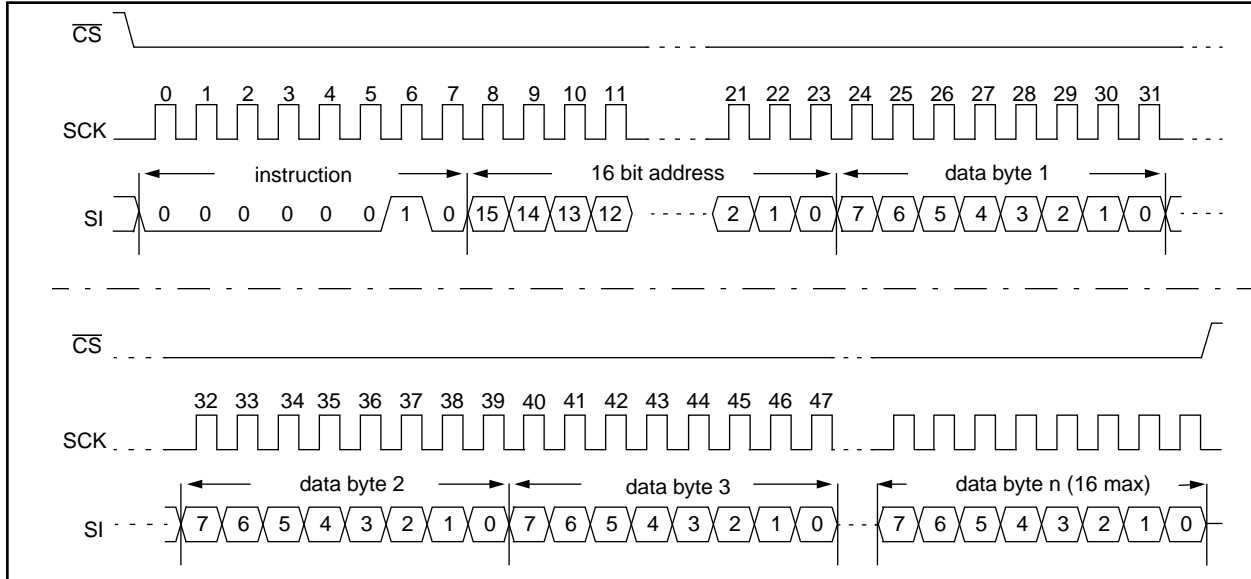
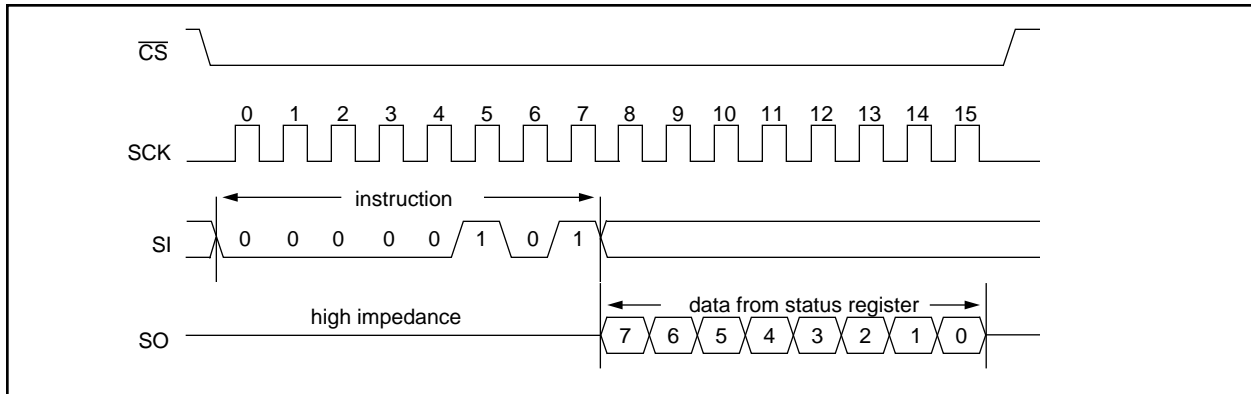
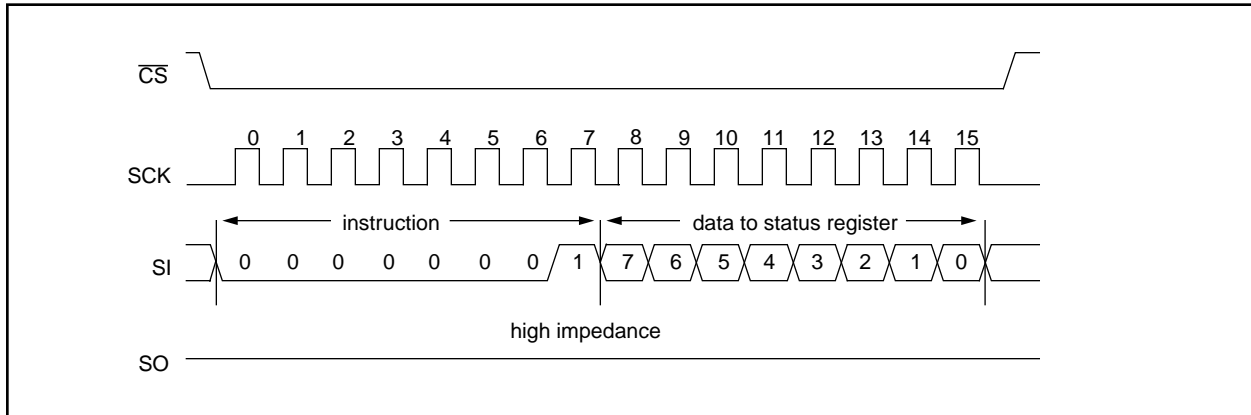

FIGURE 3-5: READ STATUS REGISTER SEQUENCE



WRITE STATUS REGISTER SEQUENCE



4.0 PIN DESCRIPTIONS

4.1 Chip Select (\overline{CS})

A low level on this pin selects the device. A high level deselects the device and forces it into standby mode. However, a programming cycle which is already in progress will be completed, regardless of the \overline{CS} input signal. If \overline{CS} is brought high during a program cycle, the device will go into standby mode as soon as the programming cycle is complete. As soon as the device is deselected, SO goes to the high impedance state, allowing multiple parts to share the same SPI bus. A low to high transition on \overline{CS} after a valid write sequence initiates an internal write cycle. After power-up, a low level on \overline{CS} is required prior to any sequence being initiated.

4.2 Serial Input (SI)

The SI pin is used to transfer data into the device. It receives instructions, addresses, and data. Data is latched on the rising edge of the serial clock.

It is possible for the SI pin and the SO pin to be tied together. With SI and SO tied together, two way communication of data can occur using only one microcontroller I/O line.

4.3 Serial Output (SO)

The SO pin is used to transfer data out of the 25LC080/160. During a read cycle, data is shifted out on this pin after the falling edge of the serial clock.

It is possible for the SI pin and the SO pin to be tied together. With SI and SO tied together, two way communication of data can occur using only one microcontroller I/O line.

4.4 Serial Clock (SCK)

The SCK is used to synchronize the communication between a master and the 25LC080/160. Instructions, addresses, or data present on the SI pin are latched on the rising edge of the clock input, while data on the SO pin is updated after the falling edge of the clock input.

4.5 Write Protect (\overline{WP})

This pin is used in conjunction with the WPEN bit in the status register to prohibit writes to the non-volatile bits in the status register. When \overline{WP} is low and WPEN is high, writing to the non-volatile bits in the status register is disabled. All other operations function normally. When \overline{WP} is high, all functions, including writes to the non-volatile bits in the status register operate normally. If the WPEN bit is set \overline{WP} low during a status register write sequence will disable writing to the status register. If an internal write cycle has already begun, \overline{WP} going low will have no effect on the write.

The \overline{WP} pin function is blocked when the WPEN bit in the status register is low. This allows the user to install the 25LC080/160 in a system with \overline{WP} pin grounded and still be able to write to the status register. The \overline{WP} pin functions will be enabled when the WPEN bit is set high.

4.6 Hold (\overline{HOLD})

The \overline{HOLD} pin is used to suspend transmission to the 25LC080/160 while in the middle of a serial sequence without having to re-transmit the entire sequence over at a later time. It should be held high any time this function is not being used. Once the device is selected and a serial sequence is underway, the \overline{HOLD} pin may be pulled low to pause further serial communication without resetting the serial sequence. The \overline{HOLD} pin must be brought low while SCK is low, otherwise the HOLD function will not be invoked until the next SCK high to low transition. The 25LC080/160 must remain selected during this sequence. The SI, SCK, and SO pins are in a high impedance state during the time the part is paused and transitions on these pins will be ignored. To resume serial communication, \overline{HOLD} must be brought high while the SCK pin is low, otherwise serial communication will not resume.

25LC080/160 Product Identification System

To order or to obtain information (e.g., on pricing or delivery), please use the listed part numbers, and refer to the factory or the listed sales offices.

25LC080/160	-	/P	
			Package:
			P = Plastic DIP (300 mil body), 8 lead
			SN = Plastic SOIC (150 mil body), 8 lead
			Temperature Range:
			Blank = 0°C to +70°C
			I = -40°C to +85°C
			Device:
			25LC080/160 SPI Bus Serial EEPROM
			25LC080T/160T SPI Bus Serial EEPROM (Tape and Reel)

Sales and Support

Products supported by a preliminary Data Sheet may possibly have an errata sheet describing minor operational differences and recommended workarounds. To determine if an errata sheet exists for a particular device, please contact one of the following:

1. Your local Microchip sales office (see next page)
2. The Microchip Corporate Literature Center U.S. FAX: (602) 786-7277
3. The Microchip's Bulletin Board, via your local CompuServe number (CompuServe membership NOT required).

Please specify which device, revision of silicon and Data Sheet (include Literature #) you are using.

For latest version information and upgrade kits for Microchip Development Tools, please call 1-800-755-2345 or 1-602-786-7302.

WORLDWIDE SALES & SERVICE

AMERICAS

Corporate Office

Microchip Technology Inc.
2355 West Chandler Blvd.
Chandler, AZ 85224-6199
Tel: 602 786-7200 Fax: 602 786-7277
Technical Support: 602 786-7627
Web: <http://www.microchip.com>

Atlanta

Microchip Technology Inc.
500 Sugar Mill Road, Suite 200B
Atlanta, GA 30350
Tel: 770 640-0034 Fax: 770 640-0307

Boston

Microchip Technology Inc.
5 Mount Royal Avenue
Marlborough, MA 01752
Tel: 508 480-9990 Fax: 508 480-8575

Chicago

Microchip Technology Inc.
333 Pierce Road, Suite 180
Itasca, IL 60143
Tel: 708 285-0071 Fax: 708 285-0075

Dallas

Microchip Technology Inc.
14651 Dallas Parkway, Suite 816
Dallas, TX 75240-8809
Tel: 972 991-7177 Fax: 972 991-8588

Dayton

Microchip Technology Inc.
Suite 150
Two Prestige Place
Miamisburg, OH 45342
Tel: 513 291-1654 Fax: 513 291-9175

Los Angeles

Microchip Technology Inc.
18201 Von Karman, Suite 1090
Irvine, CA 92612
Tel: 714 263-1888 Fax: 714 263-1338

New York

Microchip Technology Inc.
150 Motor Parkway, Suite 416
Hauppauge, NY 11788
Tel: 516 273-5305 Fax: 516 273-5335

San Jose

Microchip Technology Inc.
2107 North First Street, Suite 590
San Jose, CA 95131
Tel: 408 436-7950 Fax: 408 436-7955

Toronto

Microchip Technology Inc.
5925 Airport Road, Suite 200
Mississauga, Ontario L4V 1W1, Canada
Tel: 905 405-6279 Fax: 905 405-6253

ASIA/PACIFIC

Hong Kong

Microchip Technology
RM 3801B, Tower Two
Metroplaza
223 Hing Fong Road
Kwai Fong, N.T. Hong Kong
Tel: 852 2 401 1200 Fax: 852 2 401 3431

India

Microchip Technology
No. 6, Legacy, Convent Road
Bangalore 560 025 India
Tel: 91 80 526 3148 Fax: 91 80 559 9840

Korea

Microchip Technology
168-1, Youngbo Bldg. 3 Floor
Samsung-Dong, Kangnam-Ku,
Seoul, Korea
Tel: 82 2 554 7200 Fax: 82 2 558 5934

Shanghai

Microchip Technology
Unit 406 of Shanghai Golden Bridge Bldg.
2077 Yan'an Road West, Hongjiao District
Shanghai, Peoples Republic of China
Tel: 86 21 6275 5700
Fax: 011 86 21 6275 5060

Singapore

Microchip Technology
200 Middle Road
#10-03 Prime Centre
Singapore 188980
Tel: 65 334 8870 Fax: 65 334 8850

Taiwan, R.O.C

Microchip Technology
10F-1C 207
Tung Hua North Road
Taipei, Taiwan, ROC
Tel: 886 2 717 7175 Fax: 886 2 545 0139

EUROPE

United Kingdom

Arizona Microchip Technology Ltd.
Unit 6, The Courtyard
Meadow Bank, Furlong Road
Bourne End, Buckinghamshire SL8 5AJ
Tel: 44 1628 850303 Fax: 44 1628 850178

France

Arizona Microchip Technology SARL
Zone Industrielle de la Bonde
2 Rue du Buisson aux Fraises
91300 Massy - France
Tel: 33 1 69 53 63 20 Fax: 33 1 69 30 90 79

Germany

Arizona Microchip Technology GmbH
Gustav-Heinemann-Ring 125
D-81739 Muenchen, Germany
Tel: 49 89 627 144 0 Fax: 49 89 627 144 44

Italy

Arizona Microchip Technology SRL
Centro Direzionale Colleone Pas Taurus 1
Viale Colleoni 1
20041 Agrate Brianza
Milan Italy
Tel: 39 39 6899939 Fax: 39 39 689 9883

JAPAN

Microchip Technology Intl. Inc.
Benex S-1 6F
3-18-20, Shin Yokohama
Kohoku-Ku, Yokohama
Kanagawa 222 Japan
Tel: 81 45 471 6166 Fax: 81 45 471 6122

11/7/96



MICROCHIP

All rights reserved. © 1996, Microchip Technology Incorporated, USA. 11/96



Printed on recycled paper.

Information contained in this publication regarding device applications and the like is intended through suggestion only and may be superseded by updates. No representation or warranty is given and no liability is assumed by Microchip Technology Incorporated with respect to the accuracy or use of such information, or infringement of patents or other intellectual property rights arising from such use or otherwise. Use of Microchip's products as critical components in life support systems is not authorized except with express written approval by Microchip. No licenses are conveyed, implicitly or otherwise, under any intellectual property rights. The Microchip logo and name are registered trademarks of Microchip Technology Inc. All rights reserved. All other trademarks mentioned herein are the property of their respective companies.

Copyright © Each Manufacturing Company.

All Datasheets cannot be modified without permission.

This datasheet has been download from :

www.AllDataSheet.com

100% Free DataSheet Search Site.

Free Download.

No Register.

Fast Search System.

www.AllDataSheet.com