



AVPro[®] 5002C Dual SCART A/V Switch

October 2000

DESCRIPTION

The AVPro[®] 5002C device is an audio/video switching IC that supports an input/output port, an input only port, and an output only port. The device includes multiplexers that allow the inputs to be routed to the outputs in various configurations. Additional outputs are provided to drive an external RF modulator. The video outputs of the multiplexers are buffered to drive 137-ohm loads. The audio outputs are buffered to provide 2 V_{rms} output into 600 ohms. The 5002C has features optimized for Canal+ satellite receiver applications, but it can also be used in other applications that require control of multiple audio and video sources.

FEATURES

- Two SCART connections (Auxiliary, TV)
- Video section
 - Integrated output drivers
 - RGB, SVHS, composite outputs
 - Programmable RGB gain
- Audio section
 - Dual mode volume control
 - 0 or 6 dB gains, plus 0 to -31 dB attenuations
 - Programmable gain on DAC input channels
 - Ground based outputs (no AC coupling caps)
- Serial port control of switching I²C bus
- 64-lead LQFP package

BLOCK DIAGRAM

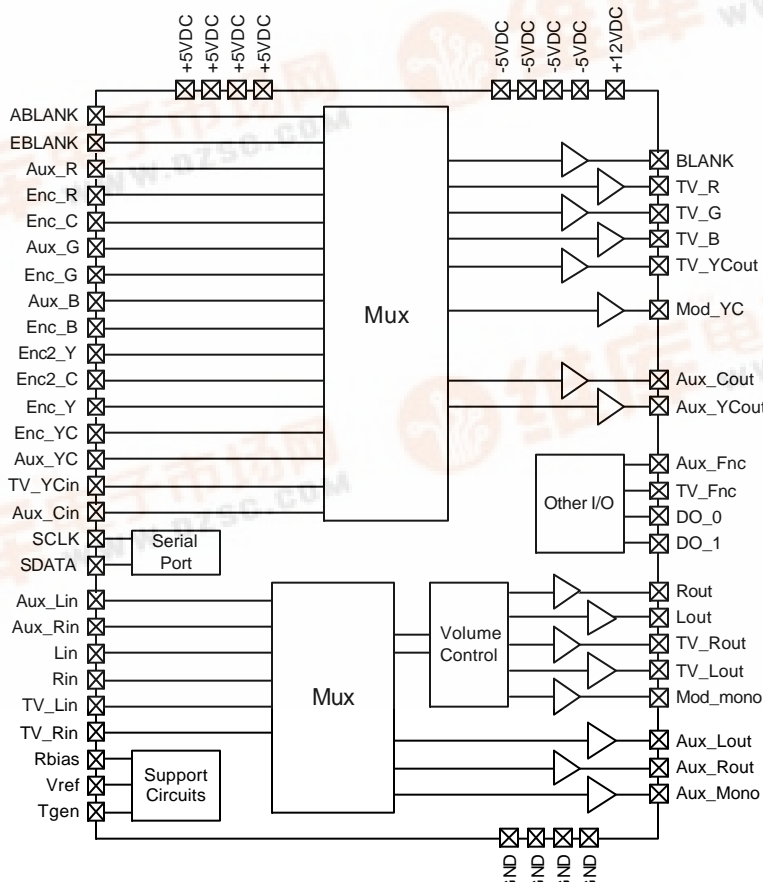

AVPro® 5002C

Dual SCART A/V Switch

FUNCTIONAL DESCRIPTION

The 5002C is an audio/video switching device. The device integrates both audio and video drivers so that it can directly drive the SCART interface. The use of a -5 volt supply eliminates the need for AC coupling capacitors on the audio outputs and the SCART audio inputs. All programmable functions of the device are controlled through a standard I²C serial interface and a set of internal registers.

The device will interface to an external video encoder that provides six video outputs. In addition, the 5002C includes two programmable digital outputs and provides inputs for the TV SCART audio/video.

SCART VIDEO SWITCHING

The device is designed to accept video signals from an auxiliary SCART connector, TV SCART connector, and an external video encoder/DAC device. The devices include a set of analog multiplexers that receive video signals from these sources and allow routing of the signals to the various video outputs. The video output drivers have a nominal gain of 2.0 V/V to allow for a series resistance of 62 ohms prior to the 75 ohm termination. A block diagram of the video switching function is provided in Figure 1. Details of the register settings are provided in the section titled "Serial Port Register Tables".

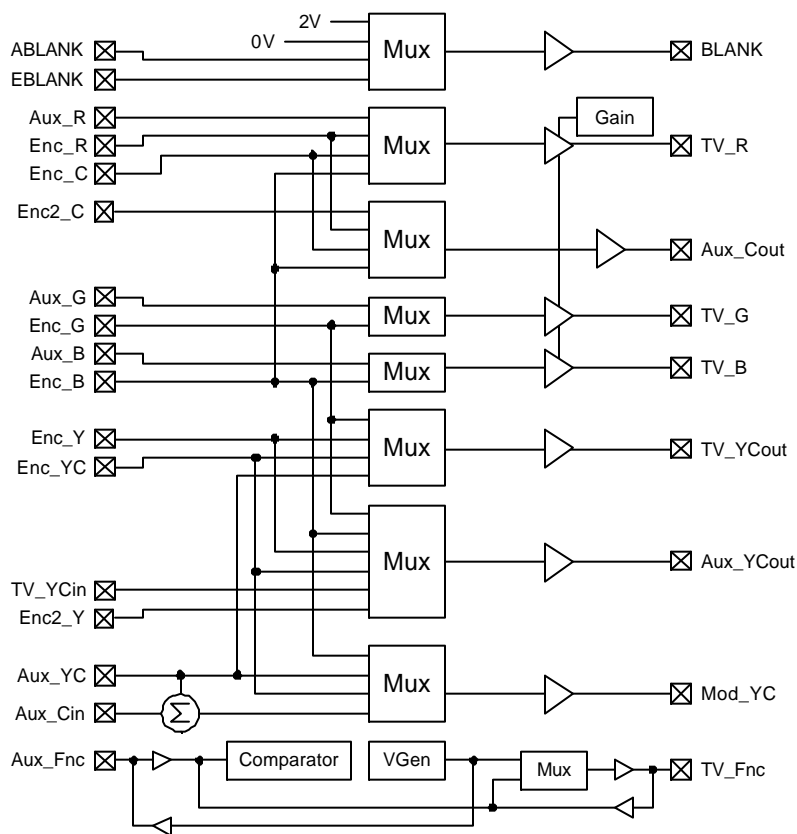

Figure 1: 5002C Video switching block diagram

AVPro[®] 5002C

Dual SCART A/V Switch

TV RGB OUTPUTS

The device accepts RGB video signals from two sources. The *Aux_R*, *Aux_G*, *Aux_B* input pins are typically connected to the auxiliary SCART connector. The *Enc_R*, *Enc_G*, *Enc_B* input pins are connected to the RGB outputs of an external video encoder device. These outputs are used as a video source for the TV SCART pins *TV_R*, *TV_G*, and *TV_B*. The RGB video source is selected by setting the lower three (3) bits of serial port Register 1. When these bits are set to xxxxx00, the RGB source will be the encoder. When these bits are set to xxxxx01, the source will be the auxiliary port. The TV RGB outputs can be muted independently from the TV composite outputs. Setting Bit 6 of Register 1 low (0) will allow normal operation. Setting Bit 6 high (1) will set the TV RGB outputs to the blank level.

RGB Gain: The gain of the RGB outputs can be adjusted to one of four different levels. Bits 4 and 5 in Register 2 set the gain of the RGB output amplifiers according to the following table:

Bit 5	Bit 4	RGB Amplifier Gain
0	0	Gain = 2.0 V/V = A ₀
0	1	Gain = A ₀ - 10%
1	0	Gain = A ₀ - 20%
1	1	Gain = A ₀ - 30%

DC Restore: The device will generate a DC restore level on each video output based on timing referenced to a horizontal sync pulse. When the sync pulse is detected, the DC restore circuit will act to position the blank level to 0.6 V at the respective video output load. The device can be programmed to look for the horizontal sync pulse on all of the RGB input pins or on the associated composite video input pin (*Aux_YC* for the auxiliary port or *Enc_YC* for the external encoder). Bit 7 of Register 1 determines the horizontal sync source. At power-up, this bit defaults to a low (0) state which programs the device to look for a sync detect on the RGB input signals. In this mode, the device can detect a horizontal sync on any of the three RGB input signals. When Bit 7 is set to a high (1) state, the device will look for a sync detect from the signal on either the *Aux_YC* or *Enc_YC* pin depending on which source is selected.

Blanking: The signal on the *Blank* output pin is determined by the state of two MSBs in Register 2 according to the following table:

Bit 7	Bit 6	Blank source
0	0	BLANK = ABLANK
0	1	BLANK = EBLANK
1	0	BLANK = 0V
1	1	BLANK = 4V @ IC output pin

The user must insure that the source of the *Blank* output is the same as the source for the RGB outputs, i.e. *ABLANK* is selected when the auxiliary RGB is active and *EBLANK* is selected when the encoder RGB is active.

TV COMPOSITE OUTPUT

The device provides inputs for two composite video sources that can be switched to the TV SCART composite video pin, *TV_YCout*. The *AUX_YC* input pin is typically connected to the "Video In" pin on the auxiliary SCART connector. The *Enc_YC* input pin is typically connected to the "YC" or "CVBS" output from the external video encoder device. Selection of the video source for the TV composite output is accomplished when the RGB video source is selected (see the register tables).

TV SVHS OUTPUT MODE

The device supports SVHS video format. The SVHS mode is selected for the TV SCART using the lower three (3) bits of Register 1. When the SVHS mode is selected, the *TV_YCout* pin will provide the luminance signal output from the selected source. The chroma output will be provided on the *TV_R* pin. The video source for SVHS mode can be either the auxiliary port or the encoder port. When the auxiliary port is selected as the video source, the video on *Aux_R* will be provided at the *TV_R* output pin and the *Aux_YC* video will be provided at the *TV_YCout* pin.

The device will support SVHS mode for three encoder interface formats. The first encoder interface format accepts chroma signals on the *Enc_C* pin and luma signals on the *Enc_Y* pin. This is designated "SVHS, Enc 1" mode. The second format will receive chroma information on the *Enc_B* pin and luma information on *Enc_G*. This format is designated "SVHS, Enc 2". The third format will receive chroma information from the *Enc_R* pin and luma information from the *Enc_G* pin. This mode is designated "SVHS, Enc 3".

When the SVHS mode is selected, the DC restore on the *TV_R* pin will average to approximately 1.8 VDC at the output pin. The DC restore circuit will act to position the blank level to 0.6 V at the *TV_YCout*

AVPro[®] 5002C

Dual SCART A/V Switch

video output load. The *TV_G* and *TV_B* outputs will be set to 0 VDC when the SVHS mode is active.

RF MODULATOR OUTPUT

The device provides an output, *Mod_YC*, to drive an external RF modulator. The *Mod_YC* output is a unity gain amplifier designed to drive a 1k load or higher. When the device is operating in the RGB mode, the signal on the *Mod_YC* output will follow the same source as the RGB and *TV_YCout* outputs.

When the device is in the SVHS mode, the *Mod_YC* output can be driven by several sources depending on the SVHS video source. These various options are detailed in the serial port register table.

One case that requires additional detail is the auxiliary SVHS mode. In the SVHS mode, the *Aux_YC* video input will only provide luma information. Composite video for the modulator output must be generated by summing this luma information with chroma information from the auxiliary port. The input pin labeled *Aux_Cin* is used for this purpose. The *Aux_Cin* input pin is AC coupled to the same source that provides the input signal to *Aux_R*. An internal summing node combines the video signal on *Aux_Cin* (chroma) with the video signal on *Aux_YC* (luma) to generate a composite video signal. In the auxiliary SVHS mode, this signal is provided at the *Mod_YC* pin.

TV COMPOSITE VIDEO MUTE

The TV composite video outputs can be muted by programming the lower three (3) bits in Register 1. The power-up default condition is xxxxx111, which sets the TV composite video outputs to 0 VDC and switches the TV audio outputs to *Aux_Lin/Aux_Rin*. Setting these bits to xxxxx110 will also mute the TV composite video outputs and switch the TV audio outputs to *Lin/Rin*.

AUXILIARY COMPOSITE OUTPUT

The auxiliary port includes a composite video output pin (*AUX_YCout*) that is typically connected to the "Video Out" pin on an auxiliary SCART connector. Bits 3-5 in Register 1 determine the source for the *AUX_YCout* pin. When these bits are set to xx00xxx, the video source will be the *Enc_B* input. When these bits are set to xx001xxx, the video source will be the *Enc_YC* input. When these bits are set to xx010xxx, the video source will be the *TV_YCin* input.

AUXILIARY SVHS OUTPUT MODE

In the SVHS mode, Pin 15 on the auxiliary SCART connector provides chroma information. To support this, the auxiliary port on the 5002C includes a chroma input pin (*Aux_Cin*) that is externally AC coupled to Pin 15 on the auxiliary SCART connector.

The device also includes an output pin (*Aux_Cout*) that provides a chroma output to Pin 15 (RED) on the auxiliary SCART connector. When connected with the *Aux_R* and *Aux_Cin* pins, this forms a bi-directional port as shown in the following diagram:

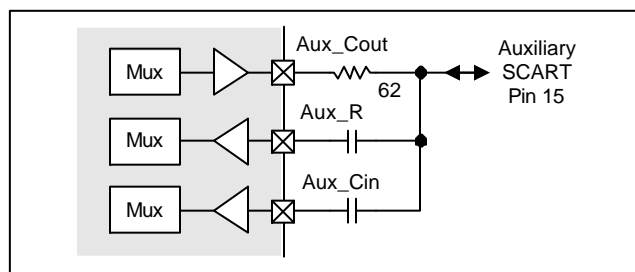

Bi-Directional Pin Circuit

Using this configuration, the device will support SVHS mode for four encoder interface formats. The first encoder interface format will receive chroma information from the *Enc_C* pin and luma information from the *Enc_Y* pin. This format is designated "SVHS, Enc 1". The second format will receive chroma information on the *Enc_B* input and luma information on *Enc_G*. This format is designated "SVHS, Enc 2". The third format will receive chroma information from the *Enc_R* pin and luma information from the *Enc_G* pin. This mode is designated "SVHS, Enc 3" on the serial port register table. For these three modes, audio will come from the *Lin/Rin* inputs. The fourth format is designated "SVHS Enc 4". Chroma information is received on the *Enc2_C* input pin and the luma is received on the *Enc2_Y* input pin. For this mode only, audio will come from the *TV_Lin/TV_Rin* inputs.

When the SVHS mode is selected, the DC restore on the *Aux_Cout* pin will average to approximately 0.9 VDC at the video output load. The DC restore on the *Aux_YCout* pin will set the blank level to 1.2 V at the IC pin or approximately 0.6 V across the video output load.

AVPro[®] 5002C

Dual SCART A/V Switch

AUXILIARY VIDEO MUTE

All auxiliary video outputs can be simultaneously disabled by programming Bits 3-5 in Register 1. The power-up default condition is *xx111xxx*, which sets all auxiliary video outputs to 0 VDC and switches the auxiliary audio outputs to *Lin/Rin*.

FUNCTION SWITCHING

The device provides functions switching pins for both the Auxiliary (*Aux_Fnc*) and TV (*TV_Fnc*) SCART ports. Both of these pins are bi-directional. The direction of the pins is determined by setting bits in Register 2 according to the following table:

Bits	<i>Aux_Fnc</i>	<i>TV_Fnc</i>
<i>xxxx00xx</i>	output	output
<i>xxxx01xx</i>	output	input
<i>xxxx10xx</i>	input	output
<i>xxxx11xx</i>	Passthru I/O	Passthru O/I

For the case where Register 2 is set to *xxxx11xx*, the input signal on the *Aux_Fnc* pin is passed directly through to the *TV_Fnc* pin as an output, or vice versa. This mode is useful when the rest of the system powers down and all signals from the auxiliary port are passed directly through to the TV port, or vice versa.

When a function pin is set as an input, the voltage on that pin is applied to an internal comparator. The comparator senses the voltage on the input pin and sets the two (2)

LSBs in the read register according to the following table:

Input voltage	Bits	Function
< 4.0 V	<i>xxxxxx00</i>	Normal TV
4.0 to 8.0V	<i>xxxxxx01</i>	16:9 aspect
>8.0 V	<i>xxxxxx10</i>	Peritelevision

When a function pin is set as an output, the output level for the pin is determined by the state of the two LSBs Register 2, according to the following table:

Bits	Output voltage	Function
<i>xxxxxx00</i>	~0 V	Normal TV
<i>xxxxxx01</i>	~6 V	16:9 aspect
<i>xxxxxx10</i>	~ 11 V	Peritelevision
<i>xxxxxx11</i>	~ 11 V	Peritelevision

Note that both the *Aux_Fnc* pin and the *TV_Fnc* pin can be set as outputs simultaneously, however they will have the same output voltage.

The function output circuit includes short circuit protection. When a function pin is in the 6V or 11V output mode, if the SCART connection is shorted to ground, then the output is disabled. Likewise, when a function pin is in the 0V output mode, if the SCART connection is connected to a voltage source, then the output is disabled. The load for the function outputs is designed to be 10k or higher.

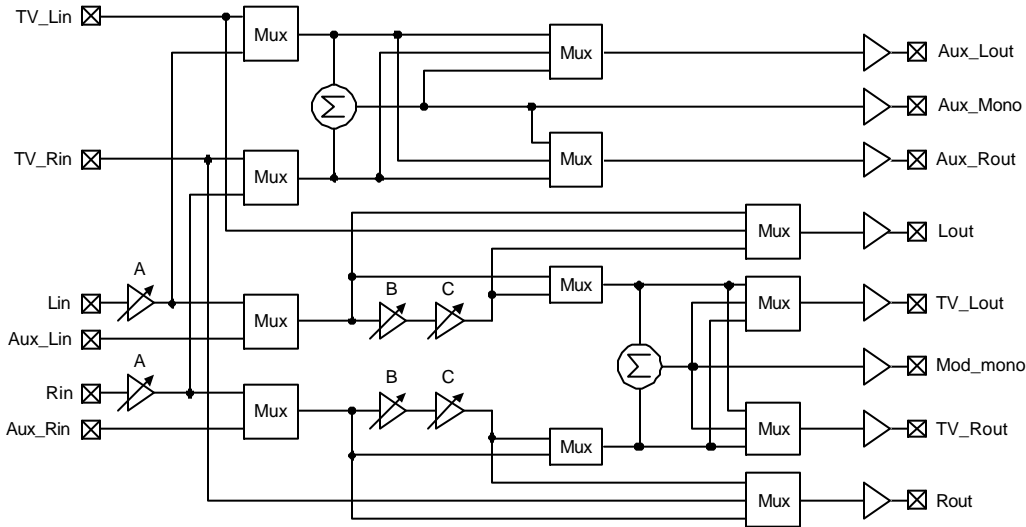

A: DAC Input Gain (0, 6, 9 or 11.6 dB)
 B: Volume Control Gain (0 or 6 dB)
 C: Volume Control Attenuation (0 to -31 dB in -1 dB steps)

Figure 2: 5002C Audio Switching Block Diagram

AVPro[®] 5002C

Dual SCART A/V Switch

SCART AUDIO SWITCHING

The audio inputs are considered to be associated with the respective video inputs. As a result, the video selection determines which audio signals will be switched to a given SCART output. Refer to the serial port register table for more information. Also see the audio switching block diagram shown in Figure 2.

The 5002C provides inputs for the auxiliary audio source (*Aux_Lin/Aux_Rin*), a stereo DAC associated with the video encoder inputs (*Lin/Rin*), and inputs from the TV SCART (*TV_Lin/TV_Rin*).

TV AUDIO OPERATION

The audio source for the TV port is selected in concert with the video source using the three (3) LSBs of Register 1. The selected audio signals are input to internal multiplexers that allow the user to select between mono and stereo output options. Bits 4 and 5 of Register 3 control the stereo/mono selection according to the following table:

Bit 1	Bit 0	TV left source	TV right source
0	0	left input	right input
0	1	left + right	left + right
1	0	left input	left input
1	1	right input	right input

At power-up, these bits default to 00 putting the device in the stereo mode.

Volume Control: The left and right TV audio channels can be selected to pass through volume control circuits. Each volume control circuit is formed by a serially connected amplifier and attenuator pair. The amplifier is programmed by register 4, bit 2 ("0" for 0 dB and "1" for 6 dB gains). The attenuator is programmed by the lower 6 bits of register 0 ("xx000000" for 0 dB and "xx111111" for -63 dB attenuations, in -1 dB steps). Only the lower 5 bits are guaranteed for accuracy (0 to -31 dB).

DAC Input Gain (*Lin/Rin*): To support audio DACs that have a limited output range, the 5002C provides programmable gain amplifiers on the *Lin* and *Rin* inputs. The gain is set by Bits 2 and 3 of Register 3, according to the following table:

Bit 3	Bit 2	Gain
0	0	Gain = 0 dB
0	1	Gain = 6 dB
1	0	Gain = 9 dB
1	1	Gain = 11.6 dB

TV SCART Audio Outputs: The first pair of signals is labeled *TV_Lout* and *TV_Rout* on the block diagram. *TV_Lout* and *TV_Rout* are typically used to drive the TV SCART audio pins. These outputs also have an internal multiplexer that allows the user to select TV audio either before or after the internal volume control function. When Bit 0 in Register 4 is set low (0), the volume control is used. When this bit is set high (1), the volume control is bypassed. The power-up default state is volume control active.

TV Audio Line Outputs: The second pair of signals is labeled *Lout* and *Rout* on the block diagram. *Lout* and *Rout* are standard line outputs. The *Lout/Rout* outputs have an internal multiplexer that allows the user to select TV audio either before or after the internal volume control function. When Bit 1 in Register 4 is set low (0), the volume control is used. When this bit is set high (1), the volume control is bypassed. The power-up default state is volume control active. In addition, the audio inputs from the TV SCART connector (*TV_Lin/TV_Rin*) can be switched to the line outputs. This is controlled by bit-3 of Register 4. Setting this bit low (0) is the normal operation where the line outputs follow the TV SCART outputs. Setting this bit high (1) will switch the line outputs to the audio source on the *TV_Lin/TV_Rin* inputs.

RF Mono Output: The *TV_Lout* and *TV_Rout* signals are also summed internally to generate a mono audio signal for an external RF modulator. This output is labeled *Mod_mono*. The internal summing circuit is after the volume control mux so the audio control on this output will be the same as that selected for the *TV_Lout* and *TV_Rout* outputs.

TV Audio Mute: A mute function is provided for all TV audio outputs. The mute function is controlled by setting Bit 6 in Register 0. When this bit is set to a high state (1), all TV audio outputs are muted. This will be the default condition at power-up. When the bit is set to a low state (0), the audio path will be in normal operating mode. This bit can be set independent of the volume control such that the outputs can be muted before any change in volume, or any switching of audio sources.

AVPro[®] 5002C

Dual SCART A/V Switch

AUXILIARY AUDIO OPERATION

The auxiliary port includes stereo audio outputs for a SCART connector (*Aux_Lout*, *Aux_Rout*) and a mono audio output (*Aux_mono*). These outputs can choose between the *Lin/Rin* input pins or the *TV_Lin/TV_Rin* input pins. The audio inputs are switched in concert with the associated video inputs according to Bits 3-5 in Register 1.

Internal multiplexers allow the *Aux_Lout* and *Aux_Rout* outputs to be configured into either stereo or mono audio outputs. The two MSBs of Register 3 control the stereo/mono selection according to the following table:

Bit 1	Bit 0	<i>Aux_Lout</i> source	<i>Aux_Rout</i> source
0	0	Lin	Rin
0	1	Lin+Rin	Lin+Rin
1	0	Lin	Lin
1	1	Rin	Rin

At power-up, these bits default to 00 putting the device in the stereo mode.

The *Aux_mono* output is generated through an internal summing node that combines the signals of the *Aux_Lout* and *Aux_Rout* outputs. All three auxiliary audio outputs can be muted by setting the MSB in Register 0. This bit is set high (1) at power-up causing the outputs to be muted. Setting this bit low (0) enables all auxiliary audio outputs.

DIGITAL OUTPUTS

The 5002C provides two programmable digital outputs, *DO_0* and *DO_1*. These pins are general purpose outputs programmed by setting Bit 0 and 1 in Register 3. Setting the register bits to 0 puts these outputs in the logic low state. Setting the register bits to 1 puts the outputs in the logic high state. Internal pull-up resistors (approximately 30k) are included on these pins.

SERIAL PORT DEFINITION

Internal functions of the device are monitored and controlled by a standard inter-IC (I²C) bus. The serial port operates in a slave mode only and can be written to or read from. The device uses 7-bit addressing, and does not support 10-bit addressing mode. The write register data is sent sequentially, such that if register 4 is to be programmed, then

register 0, 1, 2, 3 and 4 need to be sent. If only register 2 needs to be programmed, then only register 0, 1 and 2 data needs to be sent. It will support standard and fast bus speed. The default address of the device is 1001000x.

The 5002C includes a read register in which the upper four bits identify the specific chip within the AVPro[®] family. This allows a single application platform and software to work with a wide variety of AVPro[®] chips. The ID code for the 5002C is 0001.

DATA TRANSFERS

A data transfer starts when the *SDATA* pin is driven from HIGH to LOW by the bus master while the *SCLK* pin is HIGH. On the following eight clock cycles, the device receives the data on the *SDATA* pin and decodes that data to determine if a valid address has been received. The first seven bits of information are the address with the eighth bit indicating whether the cycle is a read (bit is HIGH) or a write (bit is LOW). If the address is valid for this device, on the falling *SCLK* edge of the eighth bit of data, the device will drive the *SDATA* pin low and hold it LOW until the next rising edge of the *SCLK* pin to acknowledge the address transfer. The device will continue to transmit or receive data until the bus master has issued a stop by driving the *SDATA* pin from LOW to HIGH while the *SCLK* pin is held HIGH.

Write Operation: When the read/write bit (LSB) is LOW and a valid address is decoded, the device will receive data from the *SDATA* pin. The device will continue to latch data into the registers until a stop condition is detected. The device generates an acknowledge after each byte of data written.

Read Operation: When the read/write bit (LSB) is HIGH and a valid address is decoded, the device will transmit the data from the internal register on the following eight *SCLK* cycles. Following the transfer of the register data and the acknowledge from the master, the device will release the data bus.

Reset: At power-up the serial port defaults to the states indicated in boldface type. The device also responds to the system level reset that is transmitted through the serial port. When the master sends the address 00000000 followed by the data 00000110, the device resets to the default condition. The device also generates an acknowledge.

AVPro® 5002C

Dual SCART A/V Switch

Serial Port Register Tables

Read register Device Address = 10010001

FUNCTION	BITS	DESCRIPTION
Function Control Input	xxxxxx00	TV_Fnc or AUX_Fnc pin level =Level 0 ~0V
	xxxxxx01	TV_Fnc or AUX_Fnc pin level =Level 1A ~6.0V
	xxxxxx10	TV_Fnc or AUX_Fnc pin level = Level 1B ~12V
TV_YCout video sync	xxxxx0xx	TV ycout: no sync pulse present
	xxxxx1xx	TV ycout: sync pulse present
AUX_YCout video sync	xxxx0xxx	AUX ycout: no sync pulse present
	xxxx1xxx	AUX ycout: sync pulse present
Device ID code	0001xxxx	This code identifies the device type as the 5002C

Write Registers: Device Address = 10010000 (**Bold** indicates default setting)

Register 0: Audio Control Register A

FUNCTION	BITS	DESCRIPTION
Volume Control Attenuation for TV, Line or Mod_mono audio	xx 000000	Audio volume = maximum (0 dB)
	xx011111	Audio volume = minimum (-31 dB attenuation)
	xx100000	Extended TV audio volume control range. Range is approximately -32 dB to -63 dB. Extended range is not guaranteed linear.
	xx111111	
TV audio mute	x0xxxxxx	TV audio (<i>TV_Lout/TV_Rout, Lout/Rout, Mod_mono</i>) output = normal audio output
	x 1 xxxxxx	TV audio (<i>TV_Lout/TV_Rout, Lout/Rout, Mod_mono</i>) output = Muted
AUX audio mute	0xxxxxxx	AUX audio (<i>AUX_Lout/AUX_Rout</i>) output = normal audio output
	1 xxxxxxx	AUX audio (<i>AUX_Lout/AUX_Rout</i>) output = Muted

AVPro® 5002C

Dual SCART A/V Switch

Register 1: Audio/Video Control Register; audio/video source select bits

TV A/V source	Bits	TV_R	TV_G	TV_B	TV_YC	Mod_YC	L,Rout
RGB/YC, Encoder	xxxxx000	Enc_R	Enc_G	Enc_B	Enc_YC	Enc_YC	Lin, Rin
RGB/YC, Auxiliary	xxxxx001	Aux_R	Aux_G	Aux_B	Aux_YC	Aux_YC	AuxLin,Rin
SVHS, Enc 1	xxxxx010	Enc_C	0V	0V	Enc_Y	Enc_YC	Lin, Rin
SVHS, Enc 2	xxxxx011	Enc_B	0V	0V	Enc_G	Enc_YC	Lin, Rin
SVHS, Enc 3	xxxxx100	Enc_R	0V	0V	Enc_G	Enc_B	Lin, Rin
SVHS, Aux 1	xxxxx101	Aux_R	0V	0V	Aux_YC	AuxYC+AuxCin	AuxL,Rin
TV mute	xxxxx110	Enc_R	Enc_G	Enc_B	0V	0V	Lin, Rin
TV mute	xxxxx111	Aux_R	Aux_G	Aux_B	0V	0V	AuxL,Rin
Aux A/V source	Bits	Aux_Cout		Aux_YCout		Aux_Lout, Rout	
Composite, Enc 1	xx000xxx	0V		Enc_B		Lin, Rin	
Composite, Enc 2	xx001xxx	0V		Enc_YC		Lin, Rin	
Composite, TV	xx010xxx	0V		TV_YCin		TV_Lin, TV_Rin	
SVHS, Enc 1	xx011xxx	Enc_C		Enc_Y		Lin, Rin	
SVHS, Enc 2	xx100xxx	Enc_B		Enc_G		Lin, Rin	
SVHS, Enc 3	xx101xxx	Enc_R		Enc_G		Lin, Rin	
SVHS, Enc 4	xx110xxx	Enc2_C		Enc2_Y		TV_Lin, TV_Rin	
Aux mute	xx111xxx	0V		0V		Lin, Rin	
Function	Bits	Description					
TV RGB Mute	x0xxxxxx x1xxxxxx	TV RGB outputs are active TV RGB outputs are mute (Blank level)					
RGB Sync Source	0xxxxxxx 1xxxxxxx	RGB sync /DC restore source = RGB RGB sync /DC restore source = TV_YC					

Register 2: Video Control Register; video function bits

Function	Bits	Description
Function Control Output Voltage	xxxxxx00 xxxxxx01 xxxxxx10 xxxxxx11	Level 0; normal TV output (Function Voltage = 0V) Level 1A; 16:9 aspect ratio (Function Voltage = 6V) Level 1B; Peritelevision output mode (Function Voltage = 11V) Level 1B; Peritelevision output mode (Function Voltage = 11V)
Function Pin Control*	xxxx00xx xxxx01xx xxxx10xx xxxx11xx	Aux_Fnc pin = output, TV_Fnc pin = output Aux_Fnc pin = output, TV_Fnc pin = input Aux_Fnc pin = input, TV_Fnc pin = output Signals will pass through from Aux_Fnc to TV_Fnc or vice versa.
Aux Function Pin Control*	xxxx0xxx xxxx1xxx	Aux_Fnc pin = output pin. Output is defined by LSBs of this register Aux_Fnc pin = input pin. The voltage applied to this pin sets the state of the two LSBs of the read register. See the note below*
RGB Gain Control	xx00xxxx xx01xxxx xx10xxxx xx11xxxx	RGB output amplifier gain = normal RGB output amplifiers attenuated by 10% RGB output amplifiers attenuated by 20% RGB output amplifiers attenuated by 30%
BLANK output selection	00xxxxxx 01xxxxxx 10xxxxxx 11xxxxxx	BLANK = ABLANK BLANK = EBLANK BLANK = 0V BLANK = 4V @ IC output pin

AVPro® 5002C

Dual SCART A/V Switch

* Function pin voltages: (I) in output mode, are defined by the two LSB of register 2, (II) in input mode, set the state of the two LSB of the read register.

Digital read is not meaningful in the pass-through mode(xxxx11xx).

Register 3: Audio and general purpose control register B

Function	Bits	Description
DO_0 output control	xxxxxxx0 xxxxxxx1	DO_0 output = 0 (low) DO_0 output = 1 (high)
DO_1 output control	xxxxxx0x xxxxxx1x	DO_1 output = 0 (low) DO_1 output = 1 (high)
Lin/Rin Gain control	xxxx00xx xxxx01xx xxxx10xx xxxx11xx	Input amplifier gain set at 0 dB Input amplifier gain set at 6 dB Input amplifier gain set at 9 dB Input amplifier gain set at 11.6 dB
TV Stereo/mono control	xx00xxxx xx01xxxx xx10xxxx xx11xxxx	TV audio mode: stereo TV audio mode: mono (sum L+R) on both TV_Lout and TV_Rout TV audio mode: L channel on both TV_Lout and TV_Rout TV audio mode: R channel on both TV_Lout and TV_Rout
Aux Stereo/mono control	00xxxxxx 01xxxxxx 10xxxxxx 11xxxxxx	Aux audio mode: stereo Aux audio mode: mono (sum L+R) on both Aux_Lout and Aux_Rout Aux audio mode: L channel on both Aux_Lout and Aux_Rout Aux audio mode: R channel on both Aux_Lout and Aux_Rout

Register 4: Audio control register C

Function	Bits	Description
TV volume control select 1	xxxxxxx0 xxxxxxx1	Volume control active on TV_Lout, TV_Rout; Mod_mono TV_Lout, TV_Rout; Mod_mono bypass the volume control
TV volume control select 2	xxxxxx0x xxxxxx1x	Volume control active on Lout, Rout Lout, Rout bypass the volume control
Enable 6dB gain	xxxxx0xx xxxxx1xx	0 dB of additional gain added to volume control 6 dB additional gain added to volume control
Line Out Source	xxxx0xxx xxxx1xxx	Audio on <i>Lout/Rout</i> will be the same as the <i>TV_Lout/TV_Rout</i> Audio on <i>Lout/Rout</i> will be from the <i>TV_Lin/TV_Rin</i> inputs
Not used	0000xxxx	Reserved, set to 0 for normal operation

AVPro[®] 5002C

Dual SCART A/V Switch

SCART Switching Table

INPUT PINS	OUTPUT PIN
Aux_R: Red input from Aux port Enc_R: Red input from Enc port Enc_B: Optional chroma input from Enc port Enc_C: Chroma input from Enc port	TV_R: Red video output to TV or SVHS chroma output to TV port
Aux_G: Green input from Aux port Enc_G: Green input from Enc port	TV_G: Green video output to TV port
Aux_B: Blue input from AUX SCART Enc_B: Blue input from Enc port	TV_B: Blue video output to TV port
ABLANK: Blanking input from Aux port EBLANK: Blanking input from Enc port	BLANK: TV blanking output for RGB (also can have internal 0V or 4V produced at this pin)
Aux_YC: Composite input from Aux port Enc_YC: Composite input from Enc port Enc_Y: Luma input from Enc port Enc_G: Optional luma input from Enc port	TV_YCout: Composite video, RGB sync, or Luma output to TV port
Aux_YC: Composite input from Aux port Enc_YC: Composite input from Enc port Enc_B: Optional composite input from Enc port Aux_Cin/Aux_YC: sum of chroma and luma	Mod_YC: Follows TV_YCout output. Composite (or luma sum with chroma) output to RF modulator
Enc_C: Chroma input from Enc port Enc_R: Optional chroma input from Enc port Enc_B: Optional chroma input from Enc port Enc2_C: Encoder 2 chroma input	Aux_Cout: Chroma output to auxiliary port
Enc_YC: Composite input from Enc port Enc_B: Optional composite input from Enc port Enc_G: Optional luma input from Enc port Enc_Y: Luma input from Enc port TV_YCin: Composite input from TV SCART Enc2_Y: Encoder 2 luma input	Aux_YCout: Composite video output to auxiliary port
Aux_Lin: Left audio input from Aux port Lin: Left audio input from audio DAC TV_Lin: Left audio input from TV SCART	Lout: Left audio output to RCA jack
Aux_Lin: Left audio input from Aux port Lin: Left audio input from audio DAC	TV_Lout: Left audio output to TV port
Lin: Left audio input from audio DAC TV_Lin: Left input from TV SCART	Aux_Lout: Left audio output to auxiliary port
Aux_Rin: Right audio input from Aux port Rin: Right audio input from audio DAC TV_Rin: Right audio input from TV SCART	Rout: Right audio output to RCA jack
Aux_Rin: Right audio input from Aux port Rin: Right audio input from audio DAC	TV_Rout: Right audio output to TV port
Rin: Right audio input from audio DAC TV_Rin: Right input from TV SCART	Aux_Rout: Right audio output to auxiliary port

AVPro[®] 5002C

Dual SCART A/V Switch

PIN DESCRIPTIONS (Pins marked N/C should be left unconnected during normal use)

NAME	TYPE	DESCRIPTION
Analog Pins		
ABLANK	I	Auxiliary Blanking Input: In a typical system, this pin is connected to the RGB status pin (pin 16) from the auxiliary SCART connector.
Aux_R	I	Auxiliary Red Input: In a typical system, this pin is connected to the RED input pin (pin 15) of the auxiliary SCART connector. This input can be selected as the signal source for the <i>TV_R</i> output pin.
Aux_G	I	Auxiliary Green Input: In a typical system, this pin is connected to the GREEN input pin (pin 11) of the auxiliary SCART connector. This input can be selected as the signal source for the <i>TV_G</i> output pin.
Aux_B	I	Auxiliary Blue Input: In a typical system, this pin is connected to the BLUE input pin (pin 7) of the auxiliary SCART connector. This input can be selected as the signal source for the <i>TV_B</i> output pin.
Aux_Fnc	I/O	Auxiliary Function Pin: This is a bi-directional pin. As an input, it digitizes the analog voltage on the auxiliary SCART function pin. As an output, it puts out one of three voltage levels to the auxiliary SCART function pin.
Aux_Cin	I	Auxiliary Chroma Input: In a typical application, this pin is AC coupled to the Red input line from the Auxiliary SCART connector. When the SVHS mode is selected from the Auxiliary SCART video source, this pin is internally summed to the <i>Aux_YC</i> input to generate a composite video signal for the <i>Mod_YC</i> output.
Aux_YC	I	Auxiliary Video Input: In a typical system, this pin is connected to the composite video input pin (pin 20) of the auxiliary SCART connector. This input can be selected as the signal source for the <i>TV_YCout</i> .
Aux_Lin	I	Auxiliary Left Audio Input: In a typical system, this pin is connected to the L Audio Output pin (pin 3) of the auxiliary SCART connector. This input can be selected as the signal source for the <i>TV_Lout</i> .
Aux_Rin	I	Auxiliary Right Audio Input: In a typical system, this pin is connected to the R Audio Output pin (pin 1) of the auxiliary SCART connector. This input can be selected as the signal source for the <i>TV_Rout</i> .
EBLANK	I	Encoder Blanking Input: In a typical system, this pin is connected to the blanking signal from the external video encoder device.
Enc_R	I	Encoder Red Input: In a typical system, this pin is connected to the RED output pin from the external video encoder device. This input can be selected as the signal source for the <i>TV_R</i> output pin.
Enc_G	I	Encoder Green Input: In a typical system, this pin is connected to the GREEN output pin from the external video encoder device. This input can be selected as the signal source for the <i>TV_G</i> output pin.
Enc_B	I	Encoder Blue Input: In a typical system, this pin is connected to the BLUE output pin from the external video encoder device. This input can be selected as the signal source for the <i>TV_B</i> output pin.

AVPro[®] 5002C

Dual SCART A/V Switch

PIN DESCRIPTIONS (Continued)

NAME	TYPE	DESCRIPTION
Enc_YC	I	Encoder Video Input: In a typical system, this pin is connected to the composite video output pin from the external video encoder device. This input can be selected as the signal source for the <i>AUX_YCout</i> , <i>TV_YCout</i> and/or <i>VCR_YCout</i> pins.
Enc_Y	I	Encoder Luma Input: In a typical system, this pin is connected to the composite video output pin from the external video encoder device. In SVHS mode, this input can be selected as the signal source for the <i>TV_YCout</i> pin and/or the <i>Aux_YCout</i> pin.
Enc2_Y	I	Encoder 2 Luma Input: In a typical system, this pin is used as an alternate source for S-video luma information to a VCR when OSD information is not desired. This input can be selected as the signal source for the <i>Aux_YCout</i> pin.
Enc_C	I	Encoder Chroma Input: In a typical system, this pin is connected to the <i>TV_R</i> output pin from the external video encoder device. In the SVHS mode, this input can be selected as the signal source for the <i>TV_R</i> pin and/or the <i>Aux_Cout</i> output pin.
Enc2_C	I	Encoder 2 Chroma Input: In a typical system, this pin is used as an alternate source for S-video chroma information to a VCR when OSD information is not desired. This input can be selected as the signal source for the <i>Aux_Cout</i> output pin.
Lin	I	Left Audio Input: In a typical system, this pin is connected to the left audio output pin of the external audio DAC. This input can be selected as the signal source for the <i>TV_Lout</i> and/or <i>Aux_Lout</i> pins.
Rin	I	Right Audio Input: In a typical system, this pin is connected to the right audio output pin of the external audio DAC. This input can be selected as the signal source for the <i>TV_Rout</i> and/or <i>Aux_Rout</i> pins.
TV_YCin	I	TV Composite Video input: This pin accepts composite video from the TV SCART. This pin can be selected as the source for the <i>Aux_YCout</i> pin.
TV_Lin	I	TV Left Audio input: This pin accepts audio from the TV SCART. This pin can be selected as the source for the <i>Aux_Lout</i> audio output and the <i>Lout</i> audio output.
TV_Rin	I	TV Right Audio input: This pin accepts audio from the TV SCART. This pin can be selected as the source for the <i>Aux_Rout</i> audio output and the <i>Rout</i> audio output.
Aux_YCout	O	Auxiliary Video Output: This pin is the composite video output to the auxiliary SCART connector (pin 19). In the SVHS mode, this pin is the luma output.
Aux_Lout	O	Auxiliary Left Audio Output: This pin is the output to the left channel audio (pin 3) of the auxiliary SCART connector.
Aux_Rout	O	Auxiliary Right Audio Output: This pin is the output to the right channel audio (pin1) of the auxiliary SCART connector.
Aux_Mono	O	Auxiliary Mono Output: This pin is equivalent to the sum of the output signals on <i>Aux_Lout</i> and <i>Aux_Rout</i> .
BLANK	O	Blanking output: This output provides the blanking signal to the TV SCART connector (pin 16). This signal is either the blanking signal from the auxiliary SCART connector (<i>ABLANK</i>) or the external video encoder (<i>EBLANK</i>).
Lout	O	Left Audio Output: This pin is the output to the left channel audio RCA jack.
Rout	O	Right Audio Output: This pin is the output to the right channel audio RCA jack.
Mod_Mono	O	Mono Audio Output: This pin is sum of <i>Lout</i> & <i>Rout</i> to the RF modulator input.

AVPro[®] 5002C

Dual SCART A/V Switch

PIN DESCRIPTIONS (continued)

NAME	TYPE	DESCRIPTION
Aux_Cout	O	Aux Chroma Output: This output provides a chroma signal to the auxiliary SCART connector to support SVHS operation. This pin is typically AC coupled to pin 15 of the auxiliary SCART connector. When the S-video mode is selected, a chroma signal from the video encoder is output to this pin.
Mod_YC	O	TV Modulator Video Output: This pin provides composite video for an external RF modulator. The signal on this pin follows the composite video output to the <i>TV_YCout</i> pin.
TV_YCout	O	TV Video Output: This pin is the composite video output to the TV SCART connector (pin 19). In the SVHS mode, this pin provides luminance information.
TV_R	O	TV Red Output: This pin provides Red video to the TV SCART connector (pin 15). In SVHS mode, this pin provides the chroma information.
TV_G	O	TV Green Output: This pin provides Green video to the TV SCART connector (pin 11).
TV_B	O	TV Blue Output: This pin provides Blue video to the TV SCART connector (pin 7).
TV_Lout	O	TV Left Audio Output: This pin is the output to the left channel audio (pin 3) of the TV SCART connector.
TV_Rout	O	TV Right Audio Output: This pin is the output to the right channel audio (pin1) of the TV SCART connector.
TV_Fnc	I/O	TV Function Pin: This is a bi-directional pin. As an input, it digitizes the analog voltage on the TV SCART function pin. As an output, it puts out one of three voltage levels to the TV SCART function pin.
Digital Pins		
DO_0	O	Digital Output 0: This pin is a general purpose output that is controlled by serial port register.
DO_1	O	Digital Output 1: This pin is a general purpose output that is controlled by serial port register.
SCLK	I	Serial Clock Input: This pin accepts a serial port clock input signal.
SDATA	I/O	Serial Data Input/Output that can receive or transmit serial data.
Power/Ground Pins		
VCC	-	+5 VDC power supply pins.
VEE	-	-5 VDC power supply pins.
VDD	-	+12 VDC power supply pin for function switching circuits.
Vref	-	Internal voltage reference, bypass pin. Add capacitor 0.1 uF (1.0 uF for better PSRR) to ground.
GND	-	Ground for all blocks.
Rbias	-	Bias point of internal current generator. Add resistor 10.0k (± 1%) to ground.
Tgen	-	Reference point for internal timing circuit. Add capacitor 470 pF to ground.

AVPro[®] 5002C

Dual SCART A/V Switch

ELECTRICAL SPECIFICATIONS

ABSOLUTE MAXIMUM RATINGS

Operation beyond the maximum ratings may damage the device

PARAMETER	RATING
Storage temperature	-55 to 150 °C
Junction operating temperature	+150 °C
Positive supply voltages	-0.3 V < VCC < 6V; VCC – 0.3 V < VDD < 13 V
Negative supply voltages	-6 V < VEE < +0.3 V
Voltage applied to Digital and Video Inputs	-0.3V to VCC+0.3 V
Audio input pins	VEE -0.3V to VCC+0.3 V
function input pins (300 Ω source)	-0.3V to +15 V

SPECIFICATIONS: Unless otherwise specified: 0° < Ta < 70 °C; power supplies VCC = +5.0 V ±5%, VEE = -5.0 V ±5%, VDD = 12.0 V ±5%.

PARAMETER	CONDITION	MIN	NOM	MAX	UNIT
OPERATING CHARACTERISTICS					
Power Supply Currents	All outputs loaded VCC (+5 VDC) VEE (-5 VDC) VDD (+12 VDC)		130 -37 23	150 28	mA mA mA
PSRR	f _n = 100 Hz, 0.3 V _{pp} on VCC/ VEE	40			dB
Switch time	From serial data acknowledge		2.0		μsec
Serial Port Timing(Set by I²C controller)					
SCLK Input Frequency				400	kHz
SCLK LOW time (t _{CL})		1.3			μsec
SCLK HIGH time (t _{CH})		0.6			μsec
Rise time (t _{RT})	SCLK and SDATA			300	nsec
Fall time (t _{FT})	SCLK and SDATA			300	nsec
Data set-up time* (t _{DSU})	SDATA change to SCLK HIGH	100			nsec
Data hold time* (t _{DH})	SCLK LOW to SDATA change	0			nsec
Start set-up time (t _{SSU})		0.6			μsec
Start hold time (t _{SH})		0.6			μsec
Stop set-up time (t _{PSU})		0.6			μsec
Glitch rejection	maximum pulse on SCLK and/or SDATA			50	nsec
* These specifications also apply to an acknowledge generated by the device.					

AVPro[®] 5002C

Dual SCART A/V Switch

SPECIFICATIONS (continued)

Digital I/O Characteristics (SCLK, SDATA)					
PARAMETER	CONDITION	MIN	NOM	MAX	UNIT
High level input voltage		0.7* VCC		VCC+0.3	V
Low level input voltage		GND-0.3		0.3* VCC	V
High level input current	V _{in} = V _{cc} - 1.0V	-10		10	μA
Low level input current	V _{in} = 1.0V	-10		10	μA
Low level output voltage (SDATA)	I _{OL} = 3 mA			0.4	V
Fall time (t _{FT}) V _{Ihmin} to V _{ILmax} (SDATA)	Acknowledge or read with C _L = 400pF			250	nsec
Digital I/O Characteristics (DO_0, DO_1, TV_Fnc, Aux_Fnc)					
Digital output sink current	DO_0, DO_1, Register bits read 0		1.0		mA
Digital output fall time	R _L = 10 kΩ, C _L = 15 pF		100		nsec
TV_Fnc or Aux_Fnc output level 10 k or higher load to ground	Register 2 = xxxxxx00	0.0	1.0	1.2	V
	Register 2 = xxxxxx01	4.9	6.0	6.5	V
	Register 2 = xxxxxx10 or xxxxxx11	10.0	10.5	VDD	V
	Passthrough Mode Register 2 = xxxx11xx 0.0 V ≤ V _{in} ≤ 2.0 V 4.9 V ≤ V _{in} ≤ 7.0 V 10.0 V ≤ V _{in} ≤ VDD V	0.0 4.5 9.5		2.0 7.0 VDD	V V V
TV-Fnc or AUX_Fnc input levels	Read Register = xxxxxx00	0.0		2.0	V
	Read Register = xxxxxx01	4.5		7.0	V
	Read Register = xxxxxx10	9.5		VDD	V

AVPro[®] 5002C

Dual SCART A/V Switch

Video Characteristics - Unless otherwise noted, typical output loading on all video outputs is 137Ω. All video outputs are capable of withstanding a sustained 62 ohm load to ground without damage.

Input impedance	All video inputs	100			kΩ
Input dynamic range	f _{in} = 100 kHz, THD < 1.0%		1.5		Vpp
Gain at all video outputs, Except Mod_YC	1.0 Vpp input, f _{in} = 100 kHz	1.9	2.0	2.1	V/V
Gain at Mod_YC	1.0 Vpp input, f _{in} = 100 kHz	0.95	1.0	1.05	V/V
RGB Gain control A ₀ = reading xx00xxxx gain	1.0 Vpp input, f _{in} = 100 kHz; Register 2 = xx00xxxx Register 2 = xx01xxxx Register 2 = xx10xxxx Register 2 = xx11xxxx	1.9 A ₀ -12%	2.0 A ₀ -10%	2.1 A ₀ -8%	V/V V/V V/V V/V
Output gain inequality	RGB or SVHS output channel to channel	-2.5		2.5	%
Output DC level Blank level clamp voltage	RGB, CVBS or luma outputs		1.2		V
Average level	chroma output		1.8		V
Signal to noise ratio	1 Vpp input	58	65		dB
Cross talk	f _{in} = 4.43 MHz, 1 Vpp		-55		dB
Output to output differential delay	RGB signals, f _{in} = 100 kHz	-20		20	nsec
Blanking level	Input or output, logical "0"	0.0		0.4	V
	Input or output, logical "1"	1.0		3.0	V
Blanking delay	BLANK to RGB signals	-50		50	nsec
Differential phase	TV_Ycout, Aux_Ycout and Mod_YC	-2.5		2.5	Deg.
Differential gain	TV_YCout, Aux_Ycout and Mod_YC	-5		5	%

Audio Characteristics - Unless otherwise noted, all audio outputs shall drive a load of 10 kΩ. All audio outputs will withstand a sustained short to ground without damage.

PARAMETER	CONDITION	MIN	NOM	MAX	UNIT
Input impedance			20		kΩ
Output impedance			10		Ω
Gain	f _{in} = 1.0 kHz, 0 dB settings	0.95	1.0	1.05	V/V
Frequency response	0.5 Vrms input, Flat within ± 0.3 dB	20			kHz
	Measured -3 dB point	100			kHz
Dynamic Range	f _{in} = 1.0 kHz, 0.5 Vrms; Register 4 = xxxxxx11	90			dB

AVPro® 5002C

Dual SCART A/V Switch

Audio Characteristics - Continued

PARAMETER	CONDITION	MIN	NOM	MAX	UNIT
Signal to Noise ratio	$f_{in} = 1.0$ kHz, 0.5 Vrms; Register 4 = xxxxxx11	90			dB
Distortion (THD)* Aux_Lin/Aux_Rin to all outputs	Bypass Volume Control	0.5 Vrms output		0.05	%
		2.0 Vrms output		0.1	%
	Pass through Volume Control	0.5 Vrms output		0.1	%
		2.0 Vrms output		0.35	%
Distortion (THD)* Lin/Rin to Lout/Rout, TV_Lout/TV_Rout and Mod_mono	Bypass Volume Control	0.5 Vrms output		0.1	%
		2.0 Vrms output		0.35	%
	Pass through Volume Control	0.5 Vrms output		0.05	%
		2.0 Vrms output		0.1	%
Distortion (THD)* Lin/Rin to Aux_Lout, Aux_Mono and Aux_Rout	Independent of Volume Control	0.5 Vrms output		0.1	%
		2.0 Vrms output		0.35	%
Distortion (THD)* TV_Lin/TV_Rin to all outputs	Independent of Volume Control	0.5 Vrms output		0.05	%
		2.0 Vrms output		0.1	%
DC Offset at Aux Outputs Aux_Lout, _Rout and _Mono		-55		45	mV
DC Offset at TV & Line Outputs TV_Rout, TV_Lout, Rout, Lout and Mod_Mono	Bypass Volume Control	-55		45	mV
	Volume Control Active, 0 dB gain	-100		60	mV
	Volume Control Active, 6 dB gain	-140		120	mV
Output phase matching	$f_{in} = 1.0$ kHz, 0.5 Vrms; any stereo pair		0.5		Deg.
Channel separation	$f_{in} = 1.0$ kHz, 2.0 Vrms, 0 dB attenuation	90			dB
Output attenuation (volume control) At TV_Lout/TV_Rout, Lout/Rout And Mod_mono	Reg. 0=x0000000 (0 dB attenuation) Register 4 = 00000000			0	dB
	Register 4 = 00000100			6	dB
	Reg. 0=x00111111 (31 dB attenuation) Register 4 = 00000000			-31	dB
	Register 4 = 00000100			-25	dB
	Reg. 0=x01111111 (63 dB attenuation) Register 4 = 00000000			-58	dB
	Register 4 = 00000100			-52	dB
Register 0 = x1xxxxxx (MUTE) Register 4 = 00000000			-75	dB	
Attenuation accuracy	Register 0 = 00000000 to 00011111	-5		5	%
Audio to video path skew	Video input = 1.0 Vpp @ 100 kHz Audio input = 0.5 Vrms @ 1.0 kHz		1.5		µsec

* Specified at 1 KHz frequency and 0 dB DAC Input gain and Volume Control settings.

AVPro[®] 5002C Dual SCART A/V Switch

Equivalent Circuits:

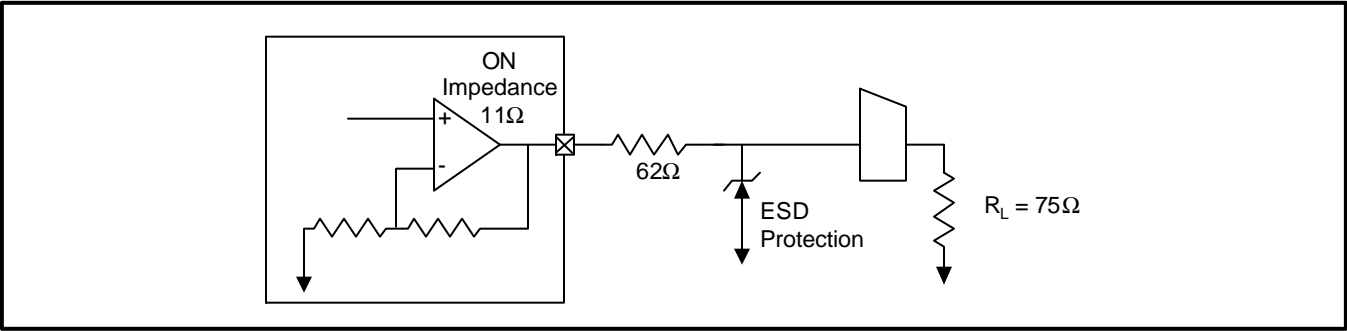

Video Output Circuit

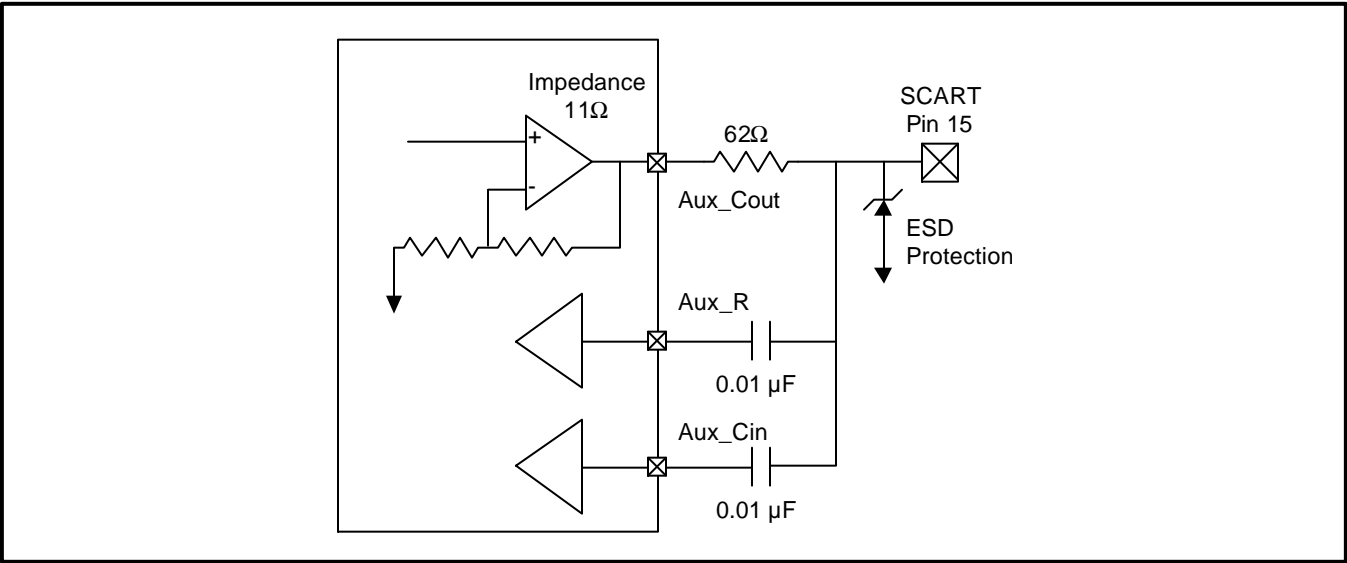

Auxiliary SCART pin 15 Circuit

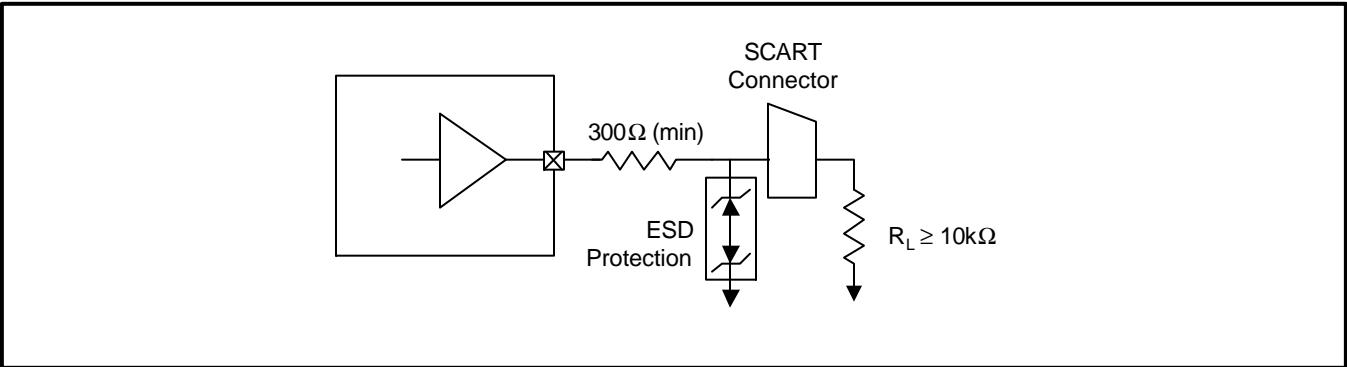

Audio Output Circuit

AVPro[®] 5002C

Dual SCART A/V Switch

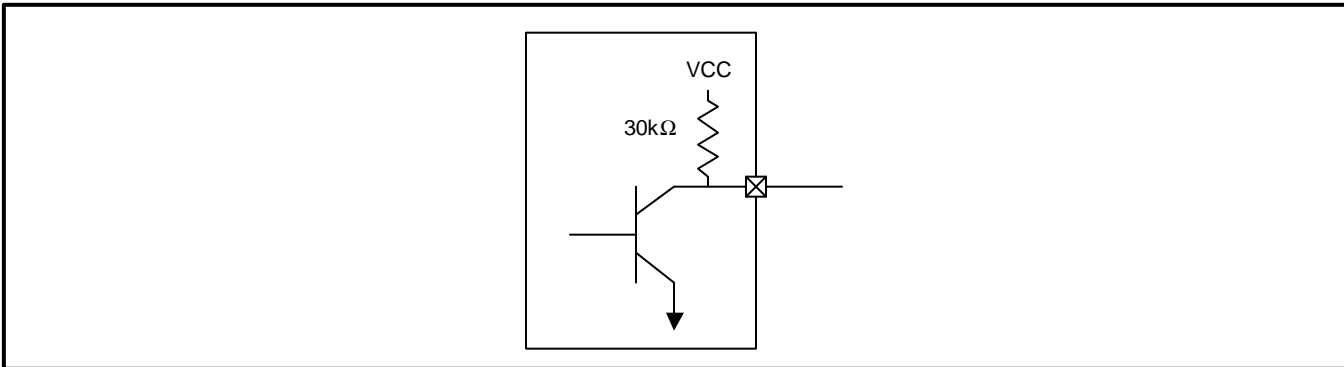

Digital Output Circuit

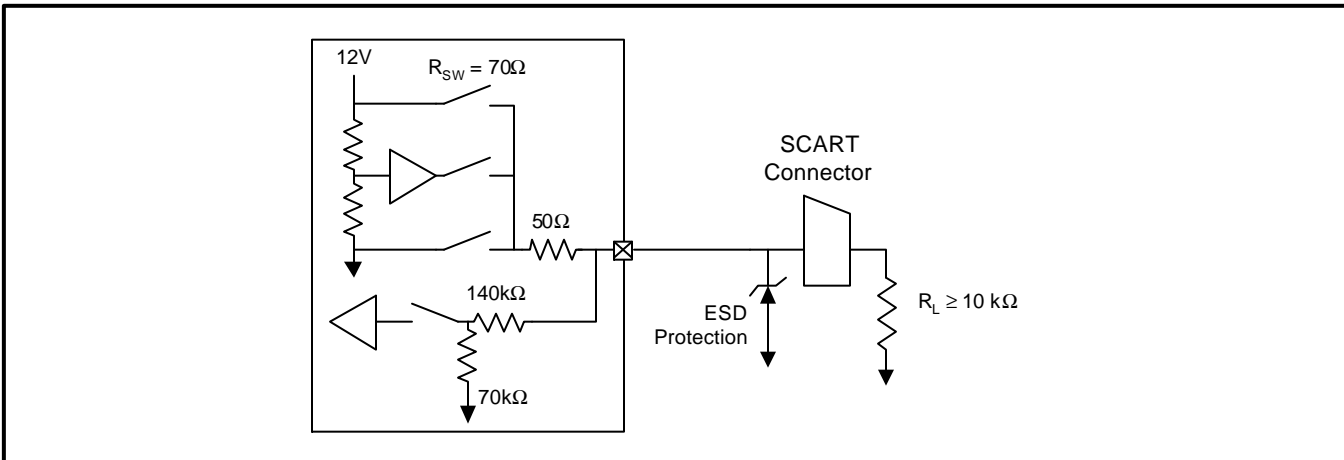

AUX and TV Function Switching Circuit

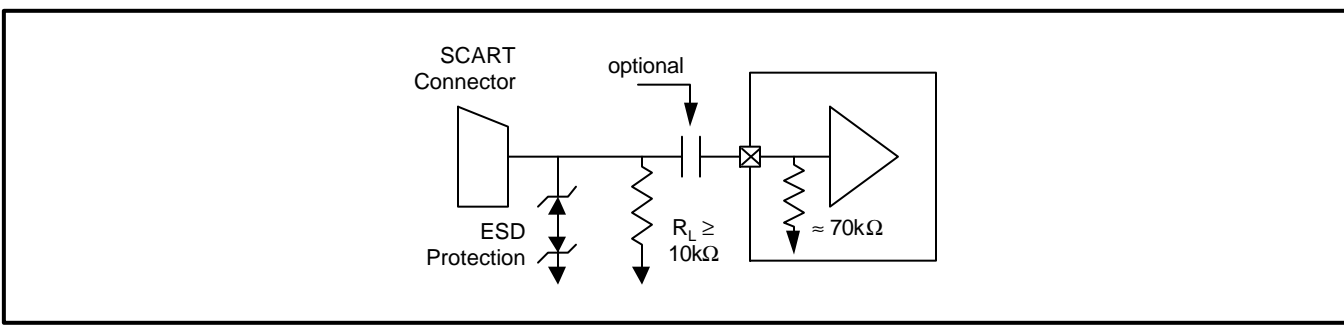

Audio Input Circuit

AVPro[®] 5002C Dual SCART A/V Switch

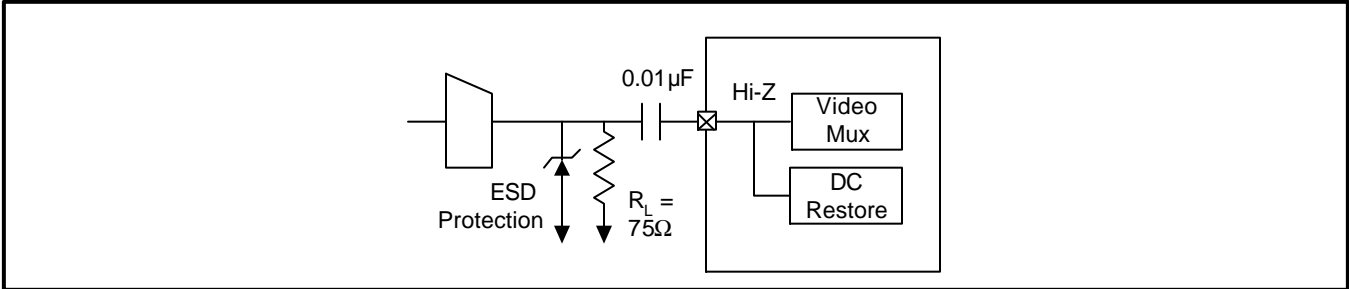

Video Input Circuit

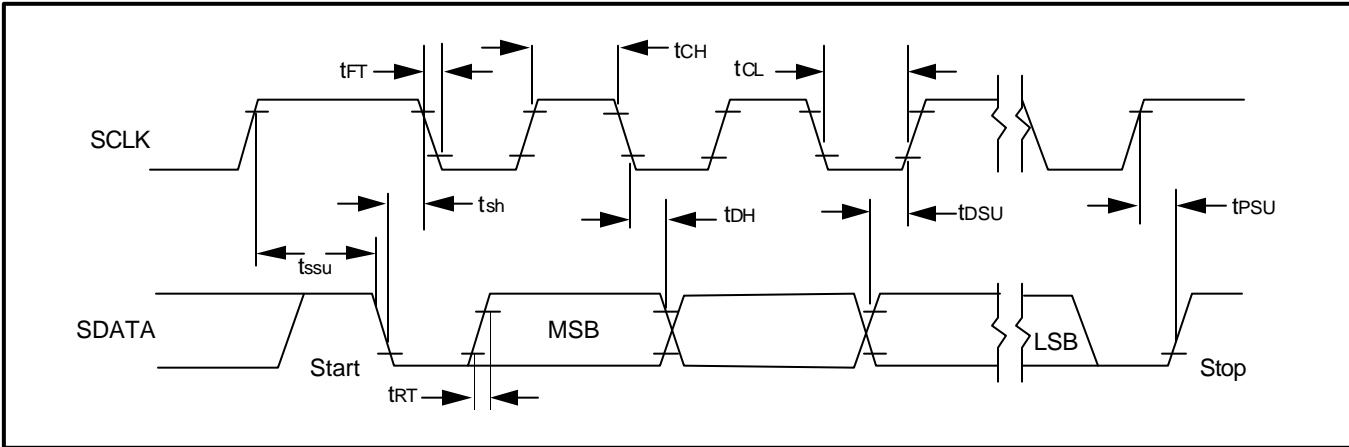

Serial Port Timing (Typical)

AVPro[®] 5002C

Dual SCART A/V Switch

PACKAGE PIN DESIGNATION

(Top View)

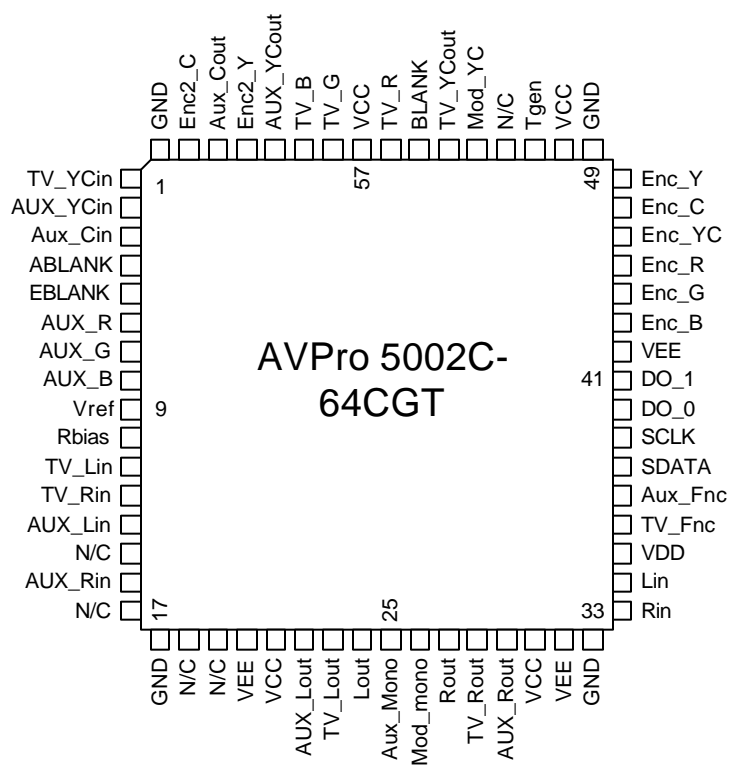

AVPro 5002C-CGT (JEDEC LQFP)

AVPro[®] 5002C Dual SCART A/V Switch

MECHANICAL DRAWING

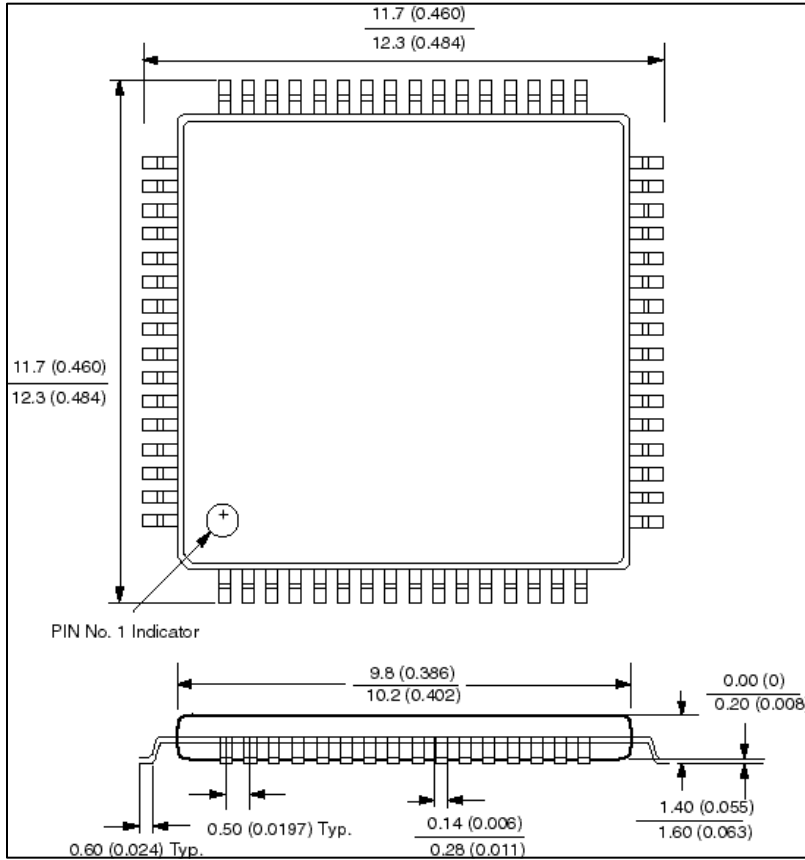

64-Lead Low Profile Plastic Quad Flatpack Package(JEDEC LQFP)

Note: Controlling dimensions are in mm.

ORDERING INFORMATION

PART DESCRIPTION	ORDER NO.	PACKAGE MARK
AVPro [®] 5002C Dual SCART A/V Switch	AVPro [®] 5002C-CGT	AVPro [®] 5002C-CGT

No responsibility is assumed by TDK Semiconductor Corporation for use of this product nor for any infringements of patents and trademarks or other rights of third parties resulting from its use. No license is granted under any patents, patent rights or trademarks of TDK Semiconductor Corporation and the company reserves the right to make changes in specifications at any time without notice. Accordingly, the reader is cautioned to verify that you are referencing the most current data sheet before placing orders. To do so, see our web site at <http://www.tdksemiconductor.com> or contact your local TDK Semiconductor representative.

Purchase of [™]C components of TDK Corporation or one of its sublicensed Associated Companies conveys a license under the Philips [™]C Patent Rights to use these components in an [™]C system, provided that the system conforms to the [™]C Standard Specification as defined by Philips.

TDK Semiconductor Corp., 2642 Michelle Dr., Tustin, CA 92780, (714) 508-8800, FAX (714) 508-8877, <http://www.tdksemiconductor.com>