



MIC5020

Current-Sensing Low-Side MOSFET Driver

General Description

The MIC5020 low-side MOSFET driver is designed to operate at frequencies greater than 100kHz (5kHz PWM for 2% to 100% duty cycle) and is an ideal choice for high-speed applications such as motor control, SMPS (switch mode power supplies), and applications using IGBTs. The MIC5020 can also operate as a circuit breaker with or without automatic retry. The MIC5020's maximum supply voltage lends itself to control applications using up to 50V. The MIC5020 can control MOSFETs that switch voltages greater than 50V.

A rising or falling edge on the input results in a current source or sink pulse on the gate output. This output current pulse can turn on or off a 2000pF MOSFET in approximately 175ns. The MIC5020 then supplies a limited current (< 2mA), if necessary, to maintain the output state.

An overcurrent comparator with a trip voltage of 50mV makes the MIC5020 ideal for use with a current sensing MOSFET. An external low value resistor may be used instead of a sensing MOSFET for more precise overcurrent control. An optional external capacitor connected to the C_T pin may be used to control the current shutdown duty cycle from 20% to < 1%. A duty cycle from 20% to about 75% is possible with an optional pull-up resistor from C_T to V_{DD}. An open collector output provides a fault indication when the sense inputs are tripped.

The MIC5020 is available in 8-pin SOIC and plastic DIP packages.

Other members of the MIC502x series include the MIC5021 high-side driver and the MIC5022 half-bridge driver with a cross-conduction interlock.

Features

- 11V to 50V operation
- 175ns rise/fall time driving 2000pF
- TTL compatible input with internal pull-down resistor
- Overcurrent limit
- Fault output indication
- Gate to source protection
- Compatible with current sensing MOSFETs

Applications

- Lamp control
- Heater control
- Motor control
- Solenoid switching
- Switch-mode power supplies
- Circuit breaker

Ordering Information

Part Number	Temperature Range	Package
MIC5020BM	-40°C to +85°C	8-pin SOIC
MIC5020BN	-40°C to +85°C	8-pin Plastic DIP

Typical Application

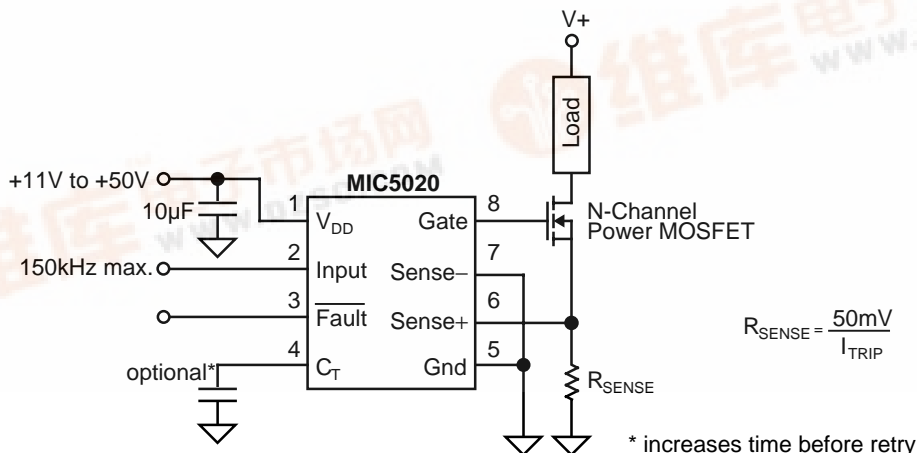

Low-Side Driver with Overcurrent Trip and Retry



Pin Configuration

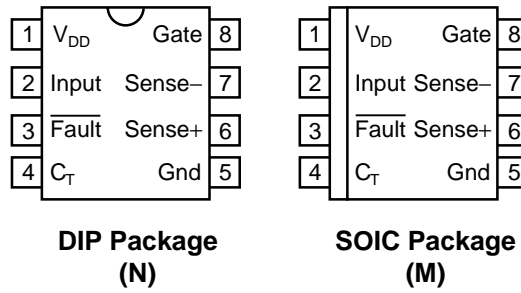

Block Diagram

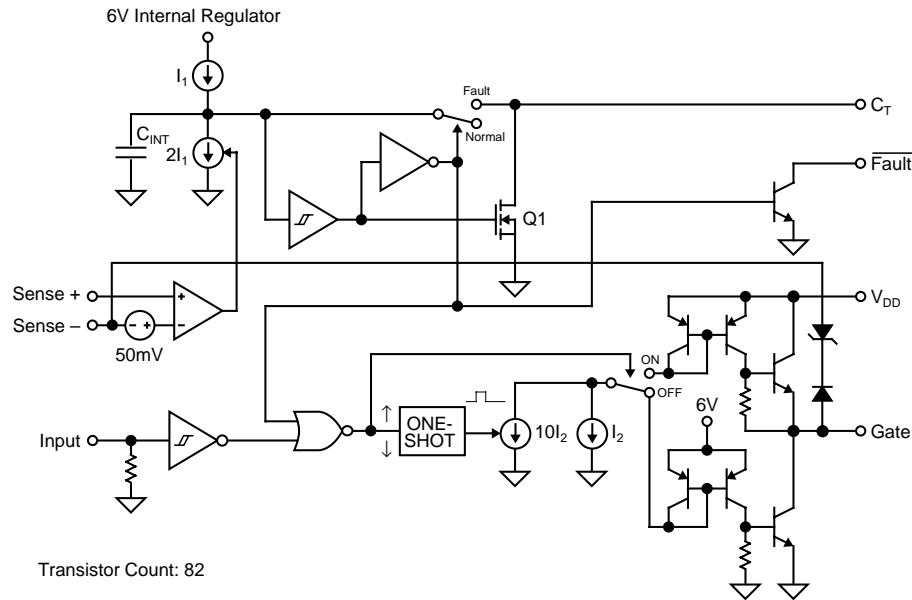

Pin Description

Pin Number	Pin Name	Pin Function
1	V _{DD}	Supply: +11V to +50V. Decouple with ≥ 10μF capacitor.
2	Input	TTL Compatible Input: Logic high turns the external MOSFET on. An internal pull-down returns an open pin to logic low.
3	Fault	Overcurrent Fault Indicator: When the sense voltage exceeds threshold, open collector output is open circuit for 5μs (t _{G(ON)}), then pulled low for t _{G(OFF)} . t _{G(OFF)} is adjustable from C _T .
4	C _T	Retry Timing Capacitor: Controls the off time (t _{G(OFF)}) of the overcurrent retry cycle. (Duty cycle adjustment.) <ul style="list-style-type: none"> • Open = 20% duty cycle. • Capacitor to Ground = approx. 20% to <1% duty cycle. • Pull-Up resistor = approx. 20% to approx. 75% duty cycle. • Ground = maintained shutdown upon overcurrent condition.
5	Gnd	Circuit Ground
6	Sense +	Current Sense Comparator (+) Input: Connect to high side of sense resistor or current sensing MOSFET sense lead. A built-in offset in conjunction with R _{SENSE} sets the load overcurrent trip point.
7	Sense -	Current Sense Comparator (-) Input: Connect to the low side of the sense resistor (usually power ground).
8	Gate	Gate Drive: Drives the gate of an external power MOSFET. Also limits V _{GS} to 15V max. to prevent Gate to Source damage. Will sink and source current.

Absolute Maximum Ratings

Supply Voltage (V_{DD})	+55V
Input Voltage	-0.5V to +15V
Sense Differential Voltage	$\pm 6.5V$
Sense + or Sense - to Gnd	-0.5V to +50V
Fault Voltage	+50V
Current into $\overline{\text{Fault}}$	50mA
Timer Voltage (C_T)	+5.5V

Operating Ratings

Supply Voltage (V_{DD})	+11V to +50V
Temperature Range	
SOIC	-40°C to +85°C
Plastic DIP	-40°C to +85°C

Electrical Characteristics

$T_A = 25^\circ\text{C}$, Gnd = 0V, $V_{DD} = 12V$, Sense +,- = 0V, Fault = Open, $C_T = \text{Open}$, Gate $C_L = 1500\text{pF}$ unless otherwise specified

Symbol	Parameter	Condition	Min	Typ	Max	Units
	D.C. Supply Current	$V_{DD} = 12V$, Input = 0V		0.8	2	mA
		$V_{DD} = 50V$, Input = 0V		2	10	mA
		$V_{DD} = 12V$, Input = 5V		0.8	2	mA
		$V_{DD} = 50V$, Input = 5V		4	25	mA
	Input Threshold		0.8	1.4	2.0	V
	Input Hysteresis			0.1		V
	Input Pull-Down Current	Input = 5V	10	20	40	μA
	Fault Output Saturation Voltage	Fault Current = 1.6mA Note 1		0.15	0.4	V
	Fault Output Leakage	Fault = 50V	-1	0.01	+1	μA
	Current Limit Threshold	Note 2	30	50	70	mV
	Gate On Voltage	$V_{DD} = 12V$	10	11		V
		$V_{DD} = 50V$	14	15	18	V
$t_{G(\text{ON})}$	Gate On Time, Fixed	Sense Differential > 70mV	2	5	10	μs
$t_{G(\text{OFF})}$	Gate Off Time, Adjustable	Sense Differential > 70mV, $C_T = 0\text{pF}$	10	20	50	μs
t_{DLH}	Gate Turn-On Delay	Note 3		400	800	ns
t_R	Gate Rise Time	Note 4		700	1500	ns
t_{DLH}	Gate Turn-Off Delay	Note 5		900	1500	ns
t_F	Gate Fall Time	Note 6		500	1500	ns
f_{max}	Maximum Operating Frequency	Note 7	100	150		kHz

Note 1 Voltage remains low for time affected by C_T .

Note 2 When using sense MOSFETs, it is recommended that $R_{\text{SENSE}} < 50\Omega$. Higher values may affect the sense MOSFET's current transfer ratio.

Note 3 Input switched from 0.8V (TTL low) to 2.0V (TTL high), time for Gate transition from 0V to 2V.

Note 4 Input switched from 0.8V (TTL low) to 2.0V (TTL high), time for Gate transition from 2V to 10V.

Note 5 Input switched from 2.0V (TTL high) to 0.8V (TTL low), time for Gate transition from 11V (Gate ON voltage) to 10V.

Note 6 Input switched from 2.0V (TTL high) to 0.8V (TTL low), time for Gate transition from 10V from 2V.

Note 7 Frequency where gate on voltage reduces to 10V with 50% input duty cycle.

Typical Characteristics

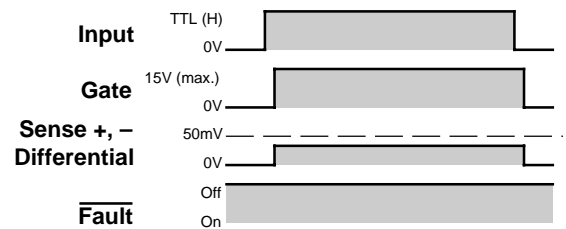
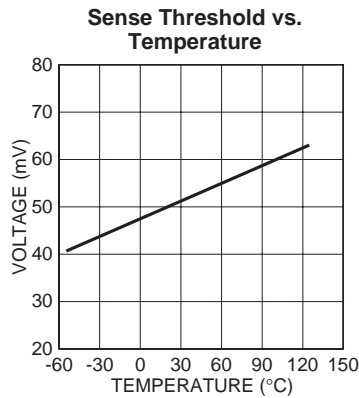
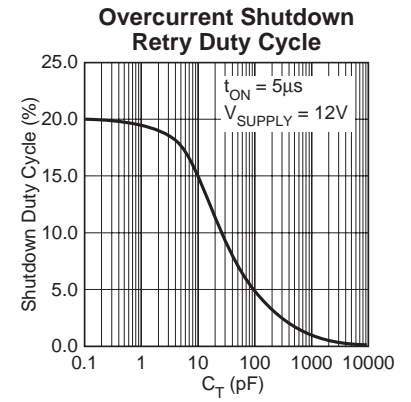
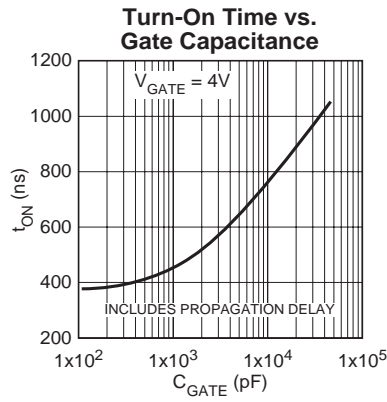
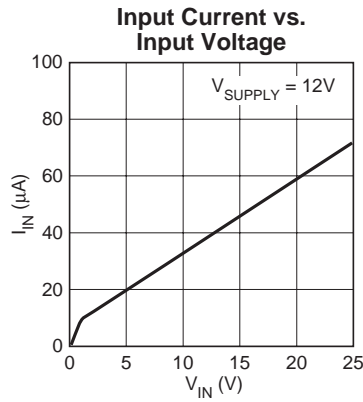
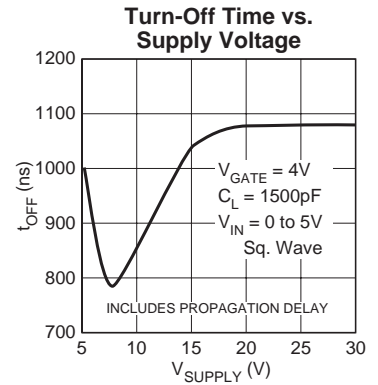
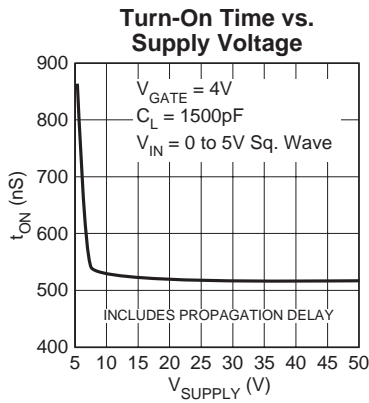
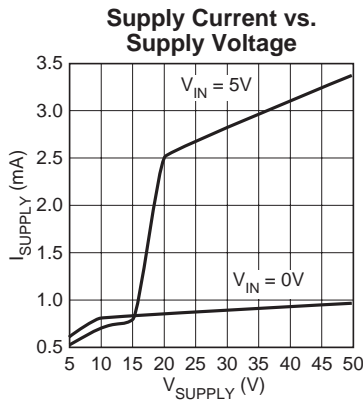

Timing Diagram 1. Normal Operation

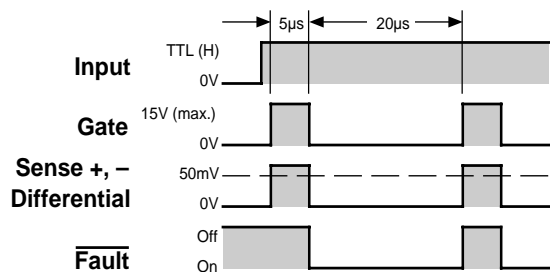

Timing Diagram 2. Fault Condition, $C_T = \text{Open}$

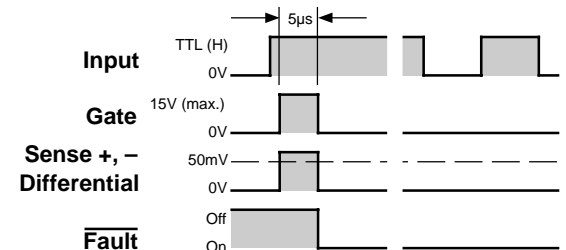

Timing Diagram 3. Fault Condition, $C_T = \text{Grounded}$

Functional Description

Refer to the MIC5020 block diagram.

Input

A signal greater than 1.4V (nominal) applied to the MIC5020 INPUT causes gate enhancement on an external MOSFET turning the external MOSFET on.

An internal pull-down resistor insures that an open INPUT remains low, keeping the external MOSFET turned off.

Gate Output

Rapid rise and fall times on the GATE output are possible because each input state change triggers a one-shot which activates a high-value current sink ($10I_2$) for a short time. This draws a high current through a current mirror circuit causing the output transistors to quickly charge or discharge the external MOSFET's gate.

A second current sink continuously draws the lower value of current used to maintain the gate voltage for the selected state.

An internal 15V Zener diode protects the external MOSFET by limiting the gate output voltage when V_{DD} is connected to higher voltages.

Overcurrent Limiting

Current source I_1 charges C_{INT} upon power up. An optional external capacitor connected to C_T is discharged through

MOSFET Q1.

A fault condition ($> 50\text{mV}$ from SENSE + to SENSE -) causes the overcurrent comparator to enable current sink $2I_1$ which overcomes current source I_1 to discharge C_{INT} in a short time. When C_{INT} is discharged, the INPUT is disabled, which turns off the GATE output; the FAULT output is enabled; and C_{INT} and C_T are ready to be charged.

When the GATE output turns the MOSFET off, the overcurrent signal is removed from the sense inputs which deactivates current sink $2I_1$. This allows C_{INT} and the optional capacitor connected to C_T to recharge. A Schmitt trigger delays the retry while the capacitor(s) recharge. Retry delay is increased by connecting a capacitor to C_T (optional).

The retry cycle will continue until the the fault is removed or the input is changed to TTL low.

If C_T is connected to ground, the circuit will not retry upon a fault condition.

Fault Output

The FAULT output is an open collector transistor. FAULT is active at approximately the same time the output is disabled by a fault condition ($5\mu\text{s}$ after an overcurrent condition is sensed). The FAULT output is open circuit (off) during each successive retry ($5\mu\text{s}$).

Applications Information

The MIC5020 MOSFET driver is intended for low-side switching applications where higher supply voltage, overcurrent sensing, and moderate speed are required.

Supply Voltage

A feature of the MIC5020 is that its supply voltage rating of up to 50V is higher than many other low-side drivers.

The minimum supply voltage required to fully enhance an N-channel MOSFET is 11V.

A lower supply voltage may be used with logic level MOSFETs. Approximately 6V is needed to provide 5V of gate enhancement.

Low-Side Switch Circuit Advantages

A moderate-speed low-side driver is generally much faster than a comparable high-side driver. The MIC5020 can provide the gate drive switching times and low propagation delay times that are necessary for high-frequency high-efficiency circuit operation in PWM (pulse width modulation) designs used for motor control, SMPS (switch mode power supply) and heating element control. Switched loads (on/off) can benefit from the MIC5020's fast switching times by allowing use of MOSFETs with smaller safe operating areas. (Larger MOSFETs are often required when using slower drivers.)

Overcurrent Limiting

A 50mV comparator is provided for current sensing. The low level trip point minimizes I^2R losses when power resistors are used for current sensing. Flexibility in choosing drain or

source side sensing is provided by access to both SENSE + and SENSE - comparator inputs.

The adjustable retry feature can be used to handle loads with high initial currents, such as lamps, motors, or heating elements and can be adjusted from the C_T connection.

C_T to ground causes maintained gate drive shutdown following overcurrent detection.

C_T open, or through a capacitor to ground, causes automatic retry. The default duty cycle (C_T open) is approximately 20%. Refer to the electrical characteristics when selecting a capacitor for a reduced duty cycle.

C_T through a pull-up resistor to V_{DD} increases the duty cycle. *Increasing the duty cycle increases the power dissipation in the load and MOSFET.* Circuits may become unstable at a duty cycles of about 75% or higher, depending on the conditions. *Caution: The MIC5020 may be damaged if the voltage on C_T exceeds the absolute maximum rating.*

An overcurrent condition is externally signaled by an open collector (FAULT) output.

The MIC5020 may be used without current sensing by connecting SENSE + and SENSE - to ground.

Current Sense Resistors

Lead length can be significant when using low value ($< 1\Omega$) resistors for current sensing. Errors caused by lead length can be avoided by using four-terminal current sensing resistors. Four-terminal resistors are available from several manufacturers.

Lamp Driver Application

Incandescent lamps have a high inrush current (low resistance) when turned on. The MIC5020 can perform a “soft start” by pulsing the MOSFET (overcurrent condition) until the filament is warm enough for its current to decrease (resistance increases). The sense resistor is selected so the voltage across the sense resistor drops below the sense threshold (50mV) as the filament becomes warm. The MOSFET is no longer pulsed to limit current and the lamp turns completely on.

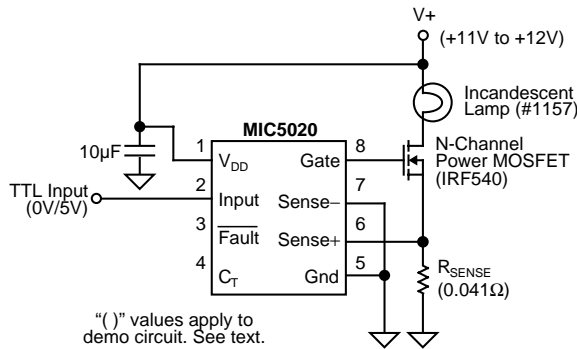

Figure 1. Lamp Driver with Current Sensing

A lamp may not fully turn on if the filament does not heat up adequately. Changing the duty cycle, sense resistor, or both to match the filament characteristics can correct the problem.

Soft start can be demonstrated using a #1157 dual-filament automotive lamp. The value of R_S shown in figure 1 allows for soft start of the higher-resistance filament (measures approx. 2.1Ω cold or 21Ω hot).

Solenoid Driver Application

The MIC5020 can be directly powered by the control voltage supply in typical 11Vdc through 50Vdc control applications. Current sensing has been omitted as an example.

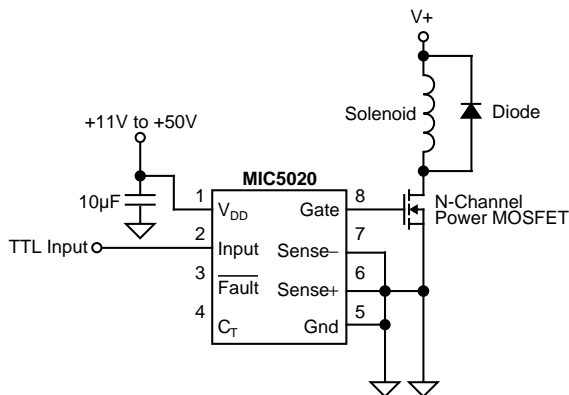

Figure 2. Solenoid Driver, Without Current Sensing

A diode across the load protects the MOSFET from the voltage spike generated by the inductive load upon MOSFET turn off. The peak forward current rating of the diode should be greater than the load current.

Current Sensing MOSFET Application

A current sensing MOSFET allows current sensing without adding additional resistance to the power switching circuit.

A current sensing MOSFET has two source connections: a “power source” for power switching and a “current source” for current sensing. The current from the current source is approximately proportional to the current through the power source, but much smaller. A current sensing ratio (I_{SOURCE}/I_{SENSE}) is provided by the MOSFET manufacturer.

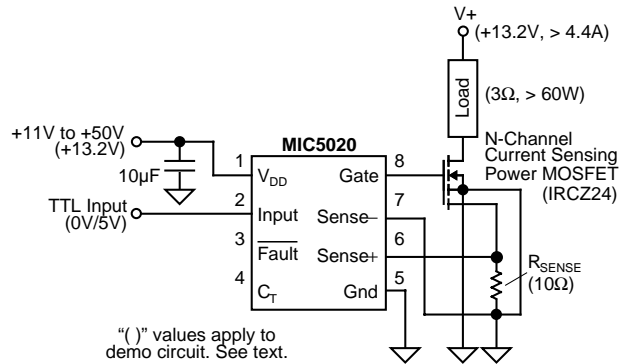

Figure 3. Using a Current Sensing MOSFET

The MOSFET current source is used to develop a voltage across a sense resistor. This voltage is monitored by the MIC5020 (SENSE + and SENSE – pins) to identify an overcurrent condition.

The value of the sense resistor can be estimated with:

$$R_{SENSE} = (r V_{TRIP} R_{DS(ON)}) / (I_{LOAD} R_{DS(ON)} - V_{TRIP})$$

where:

R_{SENSE} = external “sense” resistor

V_{TRIP} = 50mV (0.050V) for the MIC5020

r = manufacturer’s current sense ratio: (I_{SOURCE}/I_{SENSE})

$R_{DS(ON)}$ = manufacturer’s power source on resistance

I_{LOAD} = load current (power source current)

The drain to source voltage under different fault conditions affects the behavior of the MOSFET current source; that is, the current source will respond differently to a slight overcurrent condition ($V_{DS(ON)}$ very small) than to a short circuit (where $V_{DS(ON)}$ is approximately equal to the supply voltage).

Adjustment of the sense resistor value by experiment starting from the above formula will provide the quickest selection of R_{SENSE} .

Refer to manufacture’s data sheets and application notes for detailed information on current sensing MOSFET characteristics.

Figure 3 includes values which can be used to demonstrate circuit operation. The IRCZ24 MOSFET has a typical sense ratio of 780 and a $R_{DS(ON)}$ of 0.10Ω. A large 3Ω wirewound load resistor will cause inductive spikes which should be suppressed using a diode (using the same configuration as figure 2).

Faster MOSFET Switching

The MIC5020's GATE current can be multiplied using a pair of bipolar transistors to permit faster charging and discharging of the external MOSFET's gate.

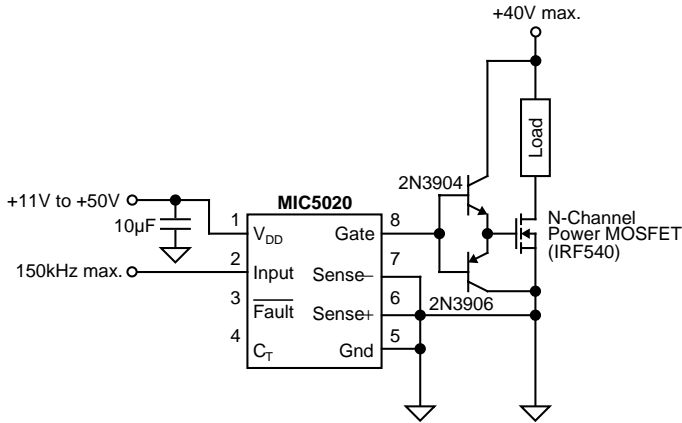

Figure 4. Faster MOSFET Switching Circuit

NPN and PNP transistors are used to respectively charge and discharge the MOSFET gate. The MIC5020 gate current is multiplied by the transistor β .

The switched circuit voltage can be increased above 40V by selecting transistors with higher ratings.

Remote Overcurrent Limiting Reset

In circuit breaker applications where the MIC5020 maintains an off condition after an overcurrent condition is sensed, the C_T pin can be used to reset the MIC5020.

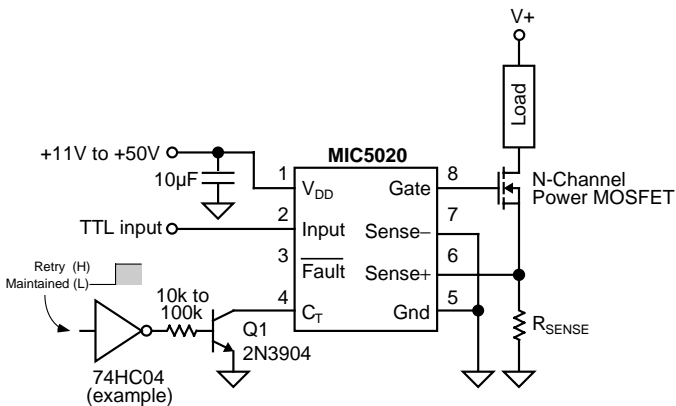

Figure 5. Remote Control Circuit

Switching Q1 on pulls C_T low which keeps the MIC5020 GATE output off when an overcurrent is sensed. Switching Q1 off causes C_T to appear open. The MIC5020 retries in about 20 μ s and continues to retry until the overcurrent condition is removed.

For test purposes, a 680 Ω load resistor and 3 Ω sense resistor will produce an overcurrent condition when the load's supply (V+) is approximately 12V or greater.

Low-Temperature Operation

As the temperature of the MIC5020AJB (extended temperature range version—no longer available) approaches -55°C , the driver's off-state, gate-output offset from ground increases. If the operating environment of the MIC5020AJB includes low temperatures (-40°C to -55°C), add an external 2.2M Ω resistor as shown in Figures 6a or 6b. This assures that the driver's gate-to-source voltage is far below the external MOSFET's gate threshold voltage, forcing the MOSFET fully off.

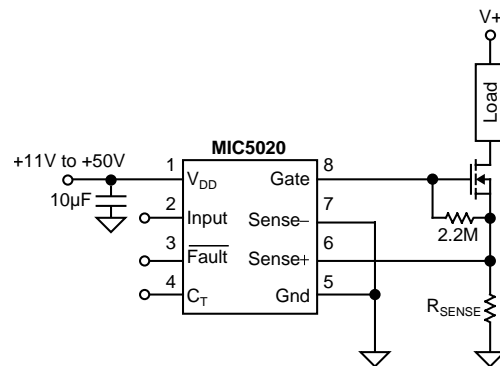

Figure 6a. Gate-to-Source Pull Down

The gate-to-source configuration (refer to Figure 6a) is appropriate for resistive and inductive loads. This also causes the smallest decrease in gate output voltage.

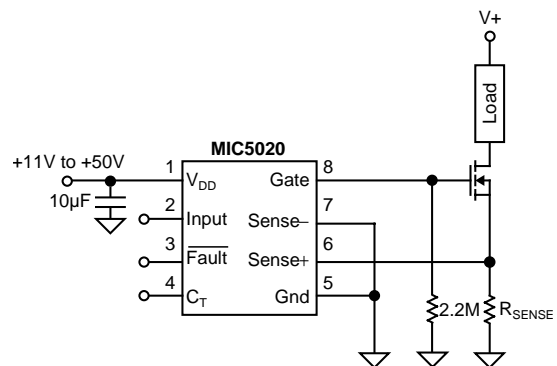

Figure 6b. Gate-to-Ground Pull Down

The gate-to-ground configuration (refer to Figure 6b) is appropriate for resistive, inductive, or capacitive loads. This configuration will decrease the gate output voltage slightly more than the circuit shown in Figure 6a.