

INTEGRATED CIRCUITS

DATA SHEET

For a complete data sheet, please also download:

- The IC06 74HC/HCT/HCU/HCMOS Logic Family Specifications
- The IC06 74HC/HCT/HCU/HCMOS Logic Package Information
- The IC06 74HC/HCT/HCU/HCMOS Logic Package Outlines

74HC/HCT4053

Triple 2-channel analog
multiplexer/demultiplexer

Product specification
File under Integrated Circuits, IC06

December 1990

Triple 2-channel analog multiplexer/demultiplexer

74HC/HCT4053

FEATURES

- Low “ON” resistance:
80 Ω (typ.) at $V_{CC} - V_{EE} = 4.5$ V
70 Ω (typ.) at $V_{CC} - V_{EE} = 6.0$ V
60 Ω (typ.) at $V_{CC} - V_{EE} = 9.0$ V
- Logic level translation:
to enable 5 V logic to communicate with ± 5 V analog signals
- Typical “break before make” built in
- Output capability: non-standard
- I_{CC} category: MSI

GENERAL DESCRIPTION

The 74HC/HCT4053 are high-speed Si-gate CMOS devices and are pin compatible with the “4053” of the “4000B” series. They are specified in compliance with JEDEC standard no. 7A.

The 74HC/HCT4053 are triple 2-channel analog multiplexers/demultiplexers with a common enable input (\bar{E}). Each multiplexer/demultiplexer has two independent inputs/outputs (nY_0 and nY_1), a common input/output (nZ) and three digital select inputs (S_1 to S_3).

With \bar{E} LOW, one of the two switches is selected (low impedance ON-state) by S_1 to S_3 . With \bar{E} HIGH, all switches are in the high impedance OFF-state, independent of S_1 to S_3 .

V_{CC} and GND are the supply voltage pins for the digital control inputs (S_1 , to S_3 , and \bar{E}). The V_{CC} to GND ranges are 2.0 to 10.0 V for HC and 4.5 to 5.5 V for HCT. The analog inputs/outputs (nY_0 and nY_1 , and nZ) can swing between V_{CC} as a positive limit and V_{EE} as a negative limit. $V_{CC} - V_{EE}$ may not exceed 10.0 V.

For operation as a digital multiplexer/demultiplexer, V_{EE} is connected to GND (typically ground).

QUICK REFERENCE DATA

$V_{EE} = \text{GND} = 0$ V; $T_{\text{amb}} = 25$ °C; $t_r = t_f = 6$ ns

SYMBOL	PARAMETER	CONDITIONS	TYPICAL		UNIT
			HC	HCT	
t_{PZH}/t_{PZL}	turn “ON” time \bar{E} to V_{OS} S_n to V_{OS}	$C_L = 15$ pF; $R_L = 1$ k Ω ; $V_{CC} = 5$ V	17	23	ns
			21	21	ns
t_{PHZ}/t_{PLZ}	turn “OFF” time \bar{E} to V_{OS} S_n to V_{OS}		18	20	ns
			17	19	ns
C_I	input capacitance		3.5	3.5	pF
C_{PD}	power dissipation capacitance per switch	notes 1 and 2	36	36	pF
C_S	max. switch capacitance independent (Y) common (Z)		5	5	pF
			8	8	pF

Notes

1. C_{PD} is used to determine the dynamic power dissipation (P_D in μ W):

$$P_D = C_{PD} \times V_{CC}^2 \times f_i + \sum \{(C_L + C_S) \times V_{CC}^2 \times f_o\} \text{ where:}$$

f_i = input frequency in MHz; f_o = output frequency in MHz

$\sum \{(C_L + C_S) \times V_{CC}^2 \times f_o\}$ = sum of outputs

C_L = output load capacitance in pF; C_S = max. switch capacitance in pF

V_{CC} = supply voltage in V

2. For HC the condition is $V_I = \text{GND}$ to V_{CC}

For HCT the condition is $V_I = \text{GND}$ to $V_{CC} - 1.5$ V

Triple 2-channel analog multiplexer/demultiplexer

74HC/HCT4053

ORDERING INFORMATION

See "74HC/HCT/HCU/HCMOS Logic Package Information".

PIN DESCRIPTION

PIN NO.	SYMBOL	NAME AND FUNCTION
2, 1	2Y ₀ to, 2Y ₁	independent inputs/outputs
5, 3	3Y ₀ to, 3Y ₁	independent inputs/outputs
6	\bar{E}	enable input (active LOW)
7	V _{EE}	negative supply voltage
8	GND	ground (0 V)
11, 10, 9	S ₁ to S ₃	select inputs
12, 13	1Y ₀ , 1Y ₁	independent inputs/outputs
14, 15, 4	1Z to 3Z	common inputs/outputs
16	V _{CC}	positive supply voltage

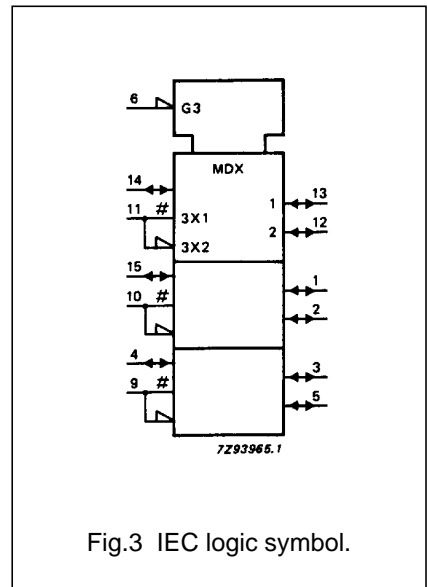
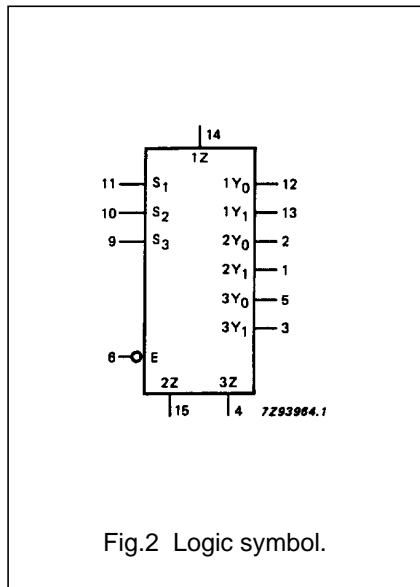
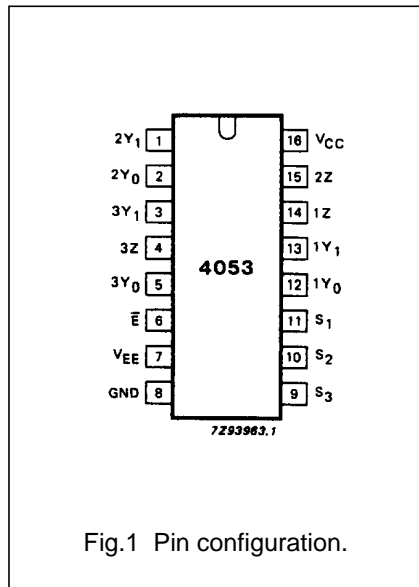

Triple 2-channel analog multiplexer/demultiplexer

74HC/HCT4053

APPLICATIONS

- Analog multiplexing and demultiplexing
- Digital multiplexing and demultiplexing
- Signal gating

FUNCTION TABLE

INPUTS		CHANNEL ON
\bar{E}	S_n	
L	L	$nY_0 - nZ$
L	H	$nY_1 - nZ$
H	X	none

Note

1. H = HIGH voltage level
L = LOW voltage level
X = don't care

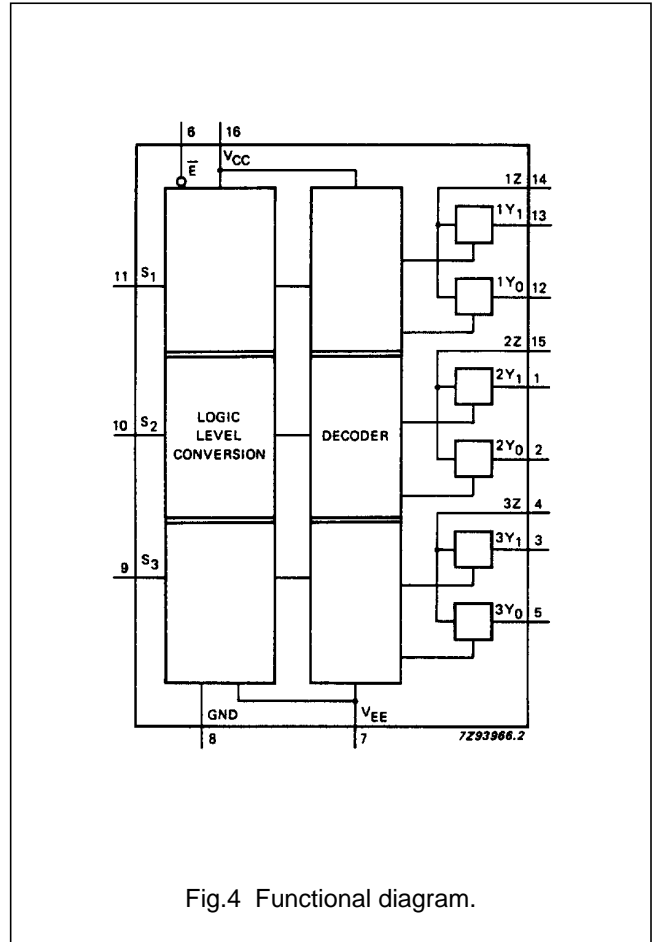

Fig.4 Functional diagram.

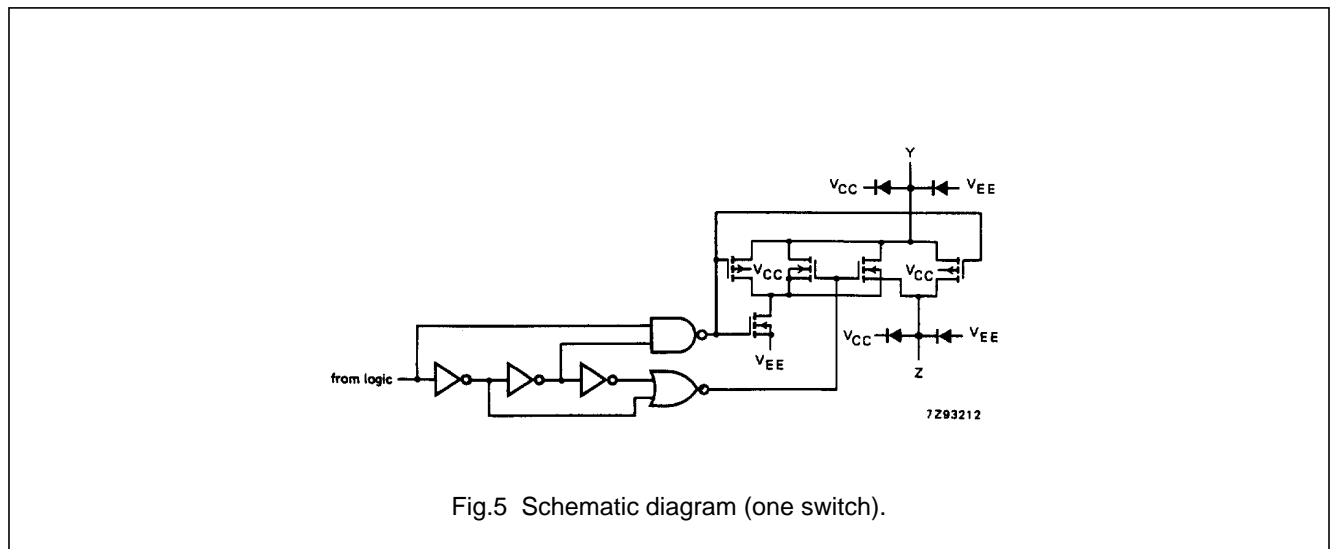

Fig.5 Schematic diagram (one switch).

Triple 2-channel analog multiplexer/demultiplexer

74HC/HCT4053

RATINGS

Limiting values in accordance with the Absolute Maximum System (IEC 134)

Voltages are referenced to $V_{EE} = \text{GND}$ (ground = 0 V)

SYMBOL	PARAMETER	MIN.	MAX.	UNIT	CONDITIONS
V_{CC}	DC supply voltage	-0.5	+11.0	V	
$\pm I_{IK}$	DC digital input diode current		20	mA	for $V_I < -0.5 \text{ V}$ or $V_I > V_{CC} + 0.5 \text{ V}$
$\pm I_{SK}$	DC switch diode current		20	mA	for $V_S < -0.5 \text{ V}$ or $V_S > V_{CC} + 0.5 \text{ V}$
$\pm I_S$	DC switch current		25	mA	for $-0.5 \text{ V} < V_S < V_{CC} + 0.5 \text{ V}$
$\pm I_{EE}$	DC V_{EE} current		20	mA	
$\pm I_{CC}; \pm I_{GND}$	DC V_{CC} or GND current		50	mA	
T_{stg}	storage temperature range	-65	+150	°C	
P_{tot}	power dissipation per package				for temperature range: -40 to + 125 °C 74HC/HCT
	plastic DIL		750	mW	above + 70 °C: derate linearly with 12 mW/K
	plastic mini-pack (SO)		500	mW	above + 70 °C: derate linearly with 8 mW/K
P_S	power dissipation per switch		100	mW	

Note to ratings

To avoid drawing V_{CC} current out of terminals nZ , when switch current flows in terminals nY_n , the voltage drop across the bidirectional switch must not exceed 0.4 V. If the switch current flows into terminals nZ , no V_{CC} current will flow out of terminals nY_n . In this case there is no limit for the voltage drop across the switch, but the voltages at nY_n and nZ may not exceed V_{CC} or V_{EE} .

RECOMMENDED OPERATING CONDITIONS

SYMBOL	PARAMETER	74HC			74HCT			UNIT	CONDITIONS
		min.	typ.	max.	min.	typ.	max.		
V_{CC}	DC supply voltage $V_{CC}-\text{GND}$	2.0	5.0	10.0	4.5	5.0	5.5	V	see Figs 6 and 7
V_{CC}	DC supply voltage $V_{CC}-V_{EE}$	2.0	5.0	10.0	2.0	5.0	10.0	V	see Figs 6 and 7
V_I	DC input voltage range	GND		V_{CC}	GND		V_{CC}	V	
V_S	DC switch voltage range	V_{EE}		V_{CC}	V_{EE}		V_{CC}	V	
T_{amb}	operating ambient temperature range	-40		+85	-40		+85	°C	see DC and AC CHARACTERISTICS
T_{amb}	operating ambient temperature range	-40		+125	-40		+125	°C	
t_r, t_f	input rise and fall times		6.0	1000 500 400 250		6.0	500	ns	$V_{CC} = 2.0 \text{ V}$ $V_{CC} = 4.5 \text{ V}$ $V_{CC} = 6.0 \text{ V}$ $V_{CC} = 10.0 \text{ V}$

Triple 2-channel analog
multiplexer/demultiplexer

74HC/HCT4053

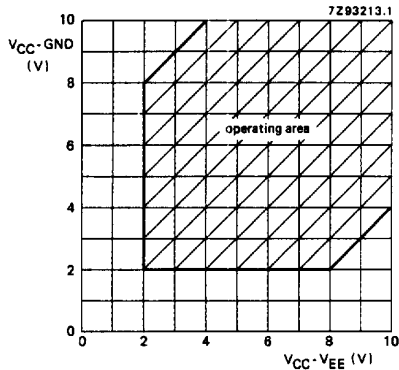

Fig.6 Guaranteed operating area as a function of the supply voltages for 74HC4053.

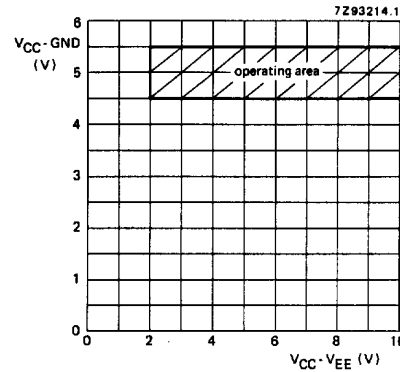

Fig.7 Guaranteed operating area as a function of the supply voltages for 74HCT4053.

DC CHARACTERISTICS FOR 74HC/HCT

For 74HC: $V_{CC} - GND$ or $V_{CC} - V_{EE} = 2.0, 4.5, 6.0$ and 9.0 V

For 74HCT: $V_{CC} - GND = 4.5$ and 5.5 V; $V_{CC} - V_{EE} = 2.0, 4.5, 6.0$ and 9.0 V

SYMBOL	PARAMETER	T_{amb} (°C)								UNIT	TEST CONDITIONS				
		74HC/HCT									V_{CC} (V)	V_{EE} (V)	I_S (μA)	V_{is}	V_I
		+ 25			-40 to +85		-40 to +125								
		min.	typ.	max.	min.	max.	min.	max.							
R_{ON}	ON resistance (peak)		-	-		-		-	Ω	2.0	0	100	V_{CC} to V_{EE}	V_{IH} or V_{IL}	
			100	180		225		270	Ω	4.5	0	1000			
			90	160		200		240	Ω	6.0	0	1000			
			70	130		165		195	Ω	4.5	-4.5	1000			
R_{ON}	ON resistance (rail)		150	-		-		-	Ω	2.0	0	100	V_{EE}	V_{IH} or V_{IL}	
			80	140		175		210	Ω	4.5	0	1000			
			70	120		150		180	Ω	6.0	0	1000			
			60	105		130		160	Ω	4.5	-4.5	1000			
R_{ON}	ON resistance (rail)		150	-		-		-	Ω	2.0	0	100	V_{CC}	V_{IH} or V_{IL}	
			90	160		200		240	Ω	4.5	0	1000			
			80	140		175		210	Ω	6.0	0	1000			
			65	120		150		180	Ω	4.5	-4.5	1000			
ΔR_{ON}	maximum ΔR_{ON} resistance between any two channels		-						Ω	2.0	0		V_{CC} to V_{EE}	V_{IH} or V_{IL}	
			9						Ω	4.5	0				
			8						Ω	6.0	0				
			6						Ω	4.5	-4.5				

Notes to the characteristics

- At supply voltages ($V_{CC} - V_{EE}$) approaching 2.0 V the analog switch ON-resistance becomes extremely non-linear. Therefore it is recommended that these devices be used to transmit digital signals only, when using these supply voltages.
- For test circuit measuring R_{ON} see Fig.8.

Triple 2-channel analog multiplexer/demultiplexer

74HC/HCT4053

DC CHARACTERISTICS FOR 74HC

Voltages are referenced to GND (ground = 0 V)

SYMBOL	PARAMETER	T _{amb} (°C)							UNIT	TEST CONDITIONS			
		74HC								V _{CC} V	V _{EE} V	V _I	OTHER
		+25			-40 to +85		-40 to +125						
		min.	typ.	max.	min.	max.	min.	max.					
V _{IH}	HIGH level input voltage	1.5 3.15 4.2 6.3	1.2 2.4 3.2 4.7		1.5 3.15 4.2 6.3		1.5 3.15 4.2 6.3		V	2.0 4.5 6.0 9.0			
V _{IL}	LOW level input voltage		0.8 2.1 2.8 4.3	0.5 1.35 1.8 2.7		0.5 1.35 1.8 2.7	0.5 1.35 1.8 2.7		V	2.0 4.5 6.0 9.0			
±I _I	input leakage current			0.1 0.2		1.0 2.0		1.0 2.0	μA	6.0 10.0	0 0	V _{CC} or GND	
±I _S	analog switch OFF-state current per channel			0.1		1.0		1.0	μA	10.0	0	V _{IH} or V _{IL}	M _S = V _{CC} - V _{EE} (see Fig.10)
±I _S	analog switch OFF-state current all channels			0.1		1.0		1.0	μA	10.0	0	V _{IH} or V _{IL}	M _S = V _{CC} - V _{EE} (see Fig.10)
±I _S	analog switch ON-state current			0.1		1.0		1.0	μA	10.0	0	V _{IH} or V _{IL}	M _S = V _{CC} - V _{EE} (see Fig.11)
I _{CC}	quiescent supply current			8.0 16.0		80.0 160.0		160.0 320.0	μA	6.0 10.0	0 0	V _{CC} or GND	V _{IS} = V _{EE} or V _{CC} ; V _{OS} = V _{CC} or V _{EE}

Triple 2-channel analog multiplexer/demultiplexer

74HC/HCT4053

AC CHARACTERISTICS FOR 74HCGND = 0 V; $t_r = t_f = 6$ ns; $C_L = 50$ pF

SYMBOL	PARAMETER	T_{amb} (°C)							UNIT	TEST CONDITIONS		
		74HC								V_{CC} (V)	V_{EE} (V)	OTHER
		+25			-40 to +85		-40 to +125					
		min.	typ.	max.	min.	max.	min.	max.				
t_{PHL}/t_{PLH}	propagation delay V_{is} to V_{os}		15	60		75		90	ns	2.0	0	$R_L = \infty$; $C_L = 50$ pF (see Fig.18)
			5	12		15		18		4.5	0	
			4	10		13		15		6.0	0	
			4	8		10		12		4.5	-4.5	
t_{PZH}/t_{PZL}	turn "ON" time \bar{E} to V_{os}		60	220		275		330	ns	2.0	0	$R_L = 1$ k Ω ; $C_L = 50$ pF (see Figs 19, 20 and 21)
			20	44		55		66		4.5	0	
			16	37		47		56		6.0	0	
			15	31		39		47		4.5	-4.5	
t_{PZH}/t_{PZL}	turn "ON" time S_n to V_{os}		75	220		275		330	ns	2.0	0	$R_L = 1$ k Ω ; $C_L = 50$ pF (see Figs 19, 20 and 21)
			25	44		55		66		4.5	0	
			20	37		47		56		6.0	0	
			15	31		39		47		4.5	-4.5	
t_{PHZ}/t_{PLZ}	turn "OFF" time \bar{E} to V_{os}		63	210		265		315	ns	2.0	0	$R_L = 1$ k Ω ; $C_L = 50$ pF (see Figs 19, 20 and 21)
			21	42		53		63		4.5	0	
			17	36		45		54		6.0	0	
			15	29		36		44		4.5	-4.5	
t_{PHZ}/t_{PLZ}	turn "OFF" time S_n to V_{os}		60	210		265		315	ns	2.0	0	$R_L = 1$ k Ω ; $C_L = 50$ pF (see Figs 19, 20 and 21)
			20	42		53		63		4.5	0	
			16	36		45		54		6.0	0	
			15	29		36		44		4.5	-4.5	

Triple 2-channel analog multiplexer/demultiplexer

74HC/HCT4053

DC CHARACTERISTICS FOR 74HCT

Voltages are referenced to GND (ground = 0 V)

SYMBOL	PARAMETER	T _{amb} (°C)							UNIT	TEST CONDITIONS			
		74HCT								V _{CC} (V)	V _{EE} (V)	V _I	OTHER
		+25			-40 to +85		-40 to +125						
		min.	typ.	max.	min.	max.	min.	max.					
V _{IH}	HIGH level input voltage	2.0	1.6		2.0		2.0		V	4.5 to 5.5			
V _{IL}	LOW level input voltage		1.2	0.8		0.8		0.8	V	4.5 to 5.5			
±I _I	input leakage current			0.1		1.0		1.0	µA	5.5	0	V _{CC} or GND	
±I _S	analog switch OFF-state current per channel			0.1		1.0		1.0	µA	10.0	0	V _{IH} or V _{IL}	M _S = V _{CC} - V _{EE} Fig.10
±I _S	analog switch OFF-state current all channels			0.1		1.0		1.0	µA	10.0	0	V _{IH} or V _{IL}	M _S = V _{CC} - V _{EE} Fig.10
±I _S	analog switch ON-state current			0.1		1.0		1.0	µA	10.0	0	V _{IH} or V _{IL}	M _S = V _{CC} - V _{EE} Fig.11
I _{CC}	quiescent supply current			8.0 16.0		80.0 160.0		160.0 320.0	µA	5.5 5.0	0 -5.0	V _{CC} or GND	V _{IS} = V _{EE} or V _{CC} ; V _{OS} = V _{CC} or V _{EE}
ΔI _{CC}	additional quiescent supply current per input pin for unit load coefficient is 1 (note 1)		100	360		450		490	µA	4.5 to 5.5	0	V _{CC} -2.1 V	other inputs at V _{CC} or GND

Note to HCT types

- The value of additional quiescent supply current (ΔI_{CC}) for a unit load of 1 is given here. To determine ΔI_{CC} per input, multiply this value by the unit load coefficient shown in the table below.

INPUT	UNIT LOAD COEFFICIENT
S _n	0.50
\bar{E}	0.50

Triple 2-channel analog multiplexer/demultiplexer

74HC/HCT4053

AC CHARACTERISTICS FOR 74HCTGND = 0 V; $t_r = t_f = 6$ ns; $C_L = 50$ pF

SYMBOL	PARAMETER	T_{amb} (°C)						UNIT	TEST CONDITIONS			
		74HCT							V_{CC} (V)	V_{EE} (V)	OTHER	
		+25			-40 to +85		-40 to +125					
		min.	typ.	max.	min.	max.	min.		max.			
t_{PHL}/t_{PLH}	propagation delay V_{is} to V_{os}		5 4	12 8		15 10		18 12	ns	4.5 4.5	0 -4.5	$R_L = \infty$; $C_L = 50$ pF (see Fig.18)
t_{PZH}/t_{PZL}	turn "ON" time \bar{E} to V_{os}		27 16	48 34		60 43		72 51	ns	4.5 4.5	0 -4.5	$R_L = 1$ k Ω ; $C_L = 50$ pF (see Figs 19, 20 and 21)
t_{PZH}/t_{PZL}	turn "ON" time S_n to V_{os}		25 16	48 34		60 43		72 51	ns	4.5 4.5	0 -4.5	$R_L = 1$ k Ω ; $C_L = 50$ pF (see Figs 19, 20 and 21)
t_{PHZ}/t_{PLZ}	turn "OFF" time \bar{E} to V_{os}		24 15	44 31		55 39		66 47	ns	4.5 4.5	0 -4.5	$R_L = 1$ k Ω ; $C_L = 50$ pF (see Figs 19, 20 and 21)
t_{PHZ}/t_{PLZ}	turn "OFF" time S_n to V_{os}		22 15	44 31		55 39		66 47	ns	4.5 4.5	0 -4.5	$R_L = 1$ k Ω ; $C_L = 50$ pF (see Figs 19, 20 and 21)

Triple 2-channel analog multiplexer/demultiplexer

74HC/HCT4053

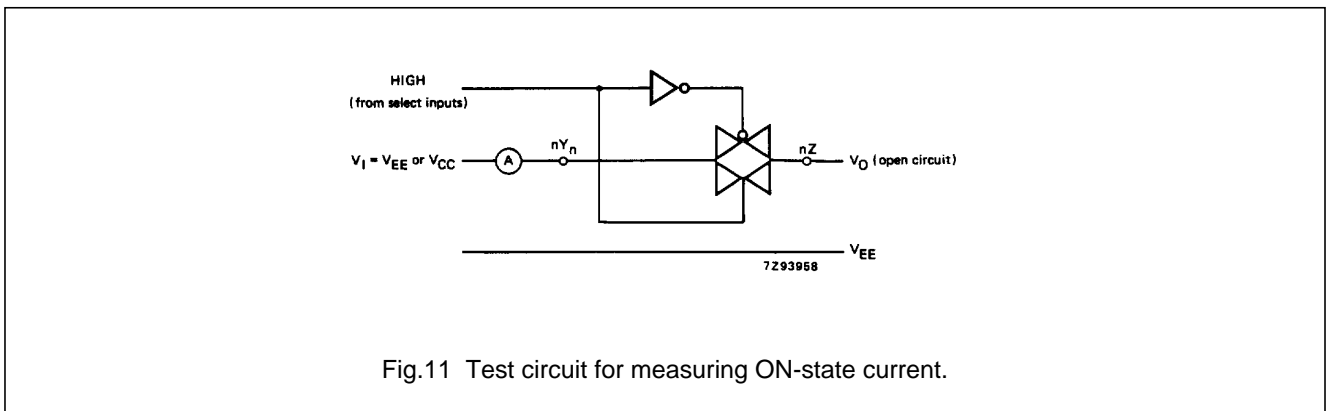
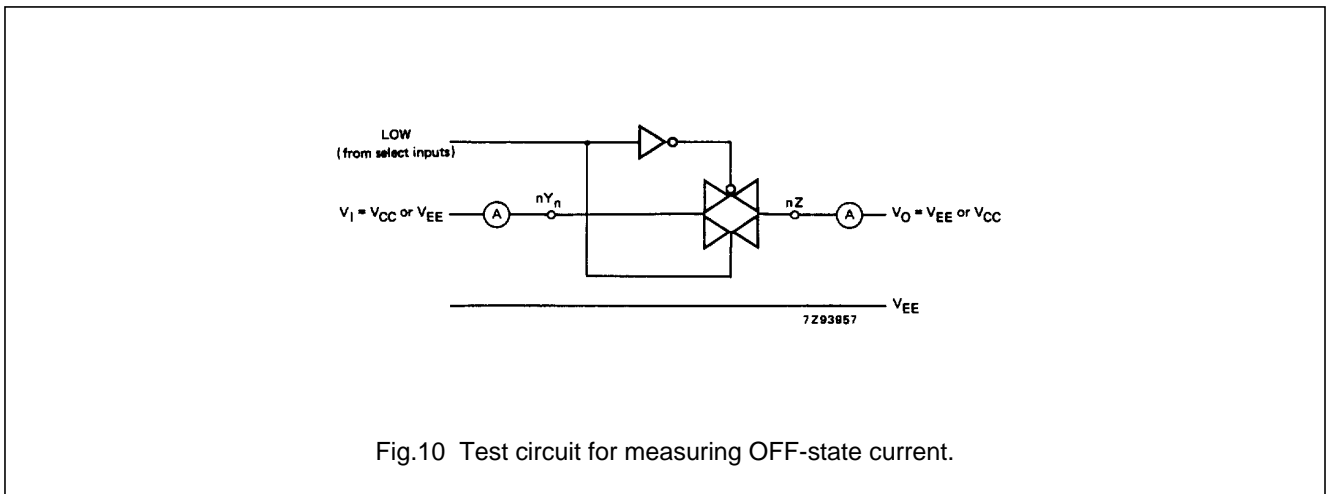
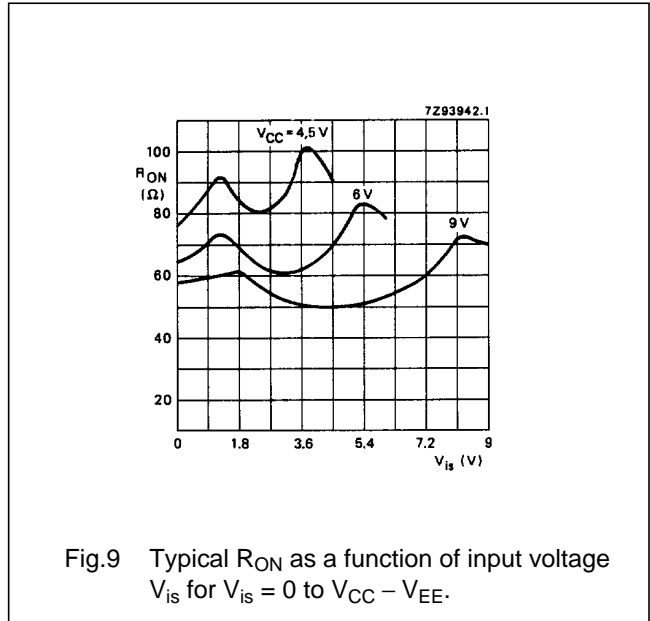
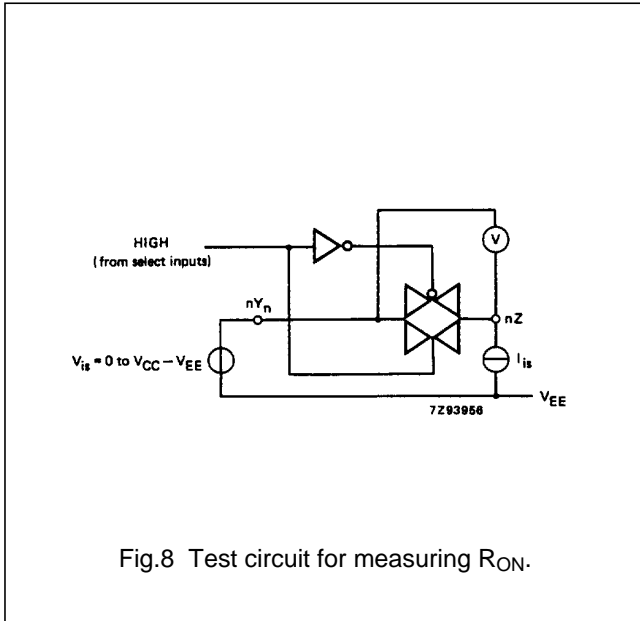

Triple 2-channel analog multiplexer/demultiplexer

74HC/HCT4053

ADDITIONAL AC CHARACTERISTICS FOR 74HC/HCT

Recommended conditions and typical values

GND = 0 V; $T_{amb} = 25\text{ }^{\circ}\text{C}$

SYMBOL	PARAMETER	typ.	UNIT	V_{CC} (V)	V_{EE} (V)	$V_{is(p-p)}$ (V)	CONDITIONS
	sine-wave distortion f = 1 kHz	0.04 0.02	% %	2.25 4.5	-2.25 -4.5	4.0 8.0	$R_L = 10\text{ k}\Omega$; $C_L = 50\text{ pF}$ (see Fig.14)
	sine-wave distortion f = 10 kHz	0.12 0.06	% %	2.25 4.5	-2.25 -4.5	4.0 8.0	$R_L = 10\text{ k}\Omega$; $C_L = 50\text{ pF}$ (see Fig.14)
	switch "OFF" signal feed-through	-50 -50	dB dB	2.25 4.5	-2.25 -4.5	note 1	$R_L = 600\text{ }\Omega$; $C_L = 50\text{ pF}$ f = 1 MHz see (Fig.12 and 15)
	crosstalk between any two switches/ multiplexers	-60 -60	dB dB	2.25 4.5	-2.25 -4.5	note 1	$R_L = 600\text{ }\Omega$; $C_L = 50\text{ pF}$; f = 1 MHz (see Fig.16)
$V_{(p-p)}$	crosstalk voltage between control and any switch (peak-to-peak value)	110 220	mV mV	4.5 4.5	0 -4.5		$R_L = 600\text{ k}\Omega$; $C_L = 50\text{ pF}$; f = 1 MHz (\bar{E} or S_n , square-wave between V_{CC} and GND, $t_r = t_f = 6\text{ ns}$ (see Fig.17)
f_{max}	minimum frequency response (-3dB)	160 170	MHz MHz	2.25 4.5	-2.25 -4.5	note 2	$R_L = 50\text{ }\Omega$; $C_L = 10\text{ pF}$ (see Fig.13 and 14)
C_S	maximum switch capacitance independent (Y) common (Z)	5 8	pF pF				

Notes to the AC characteristics

1. Adjust input voltage V_{is} to 0 dBm level (0 dBm = 1 mW into 600 Ω).
2. Adjust input voltage V_{is} to 0 dBm level at V_{OS} for 1 MHz (0 dBm = 1 mW into 50 Ω).

General note

V_{is} is the input voltage at an nY_n or nZ terminal, whichever is assigned as an input.

V_{OS} is the output voltage at an nY_n or nZ terminal, whichever is assigned as an output

Triple 2-channel analog multiplexer/demultiplexer

74HC/HCT4053

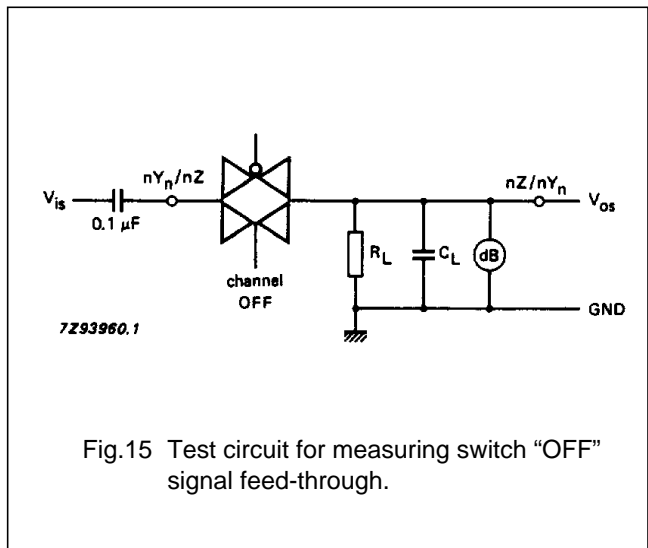
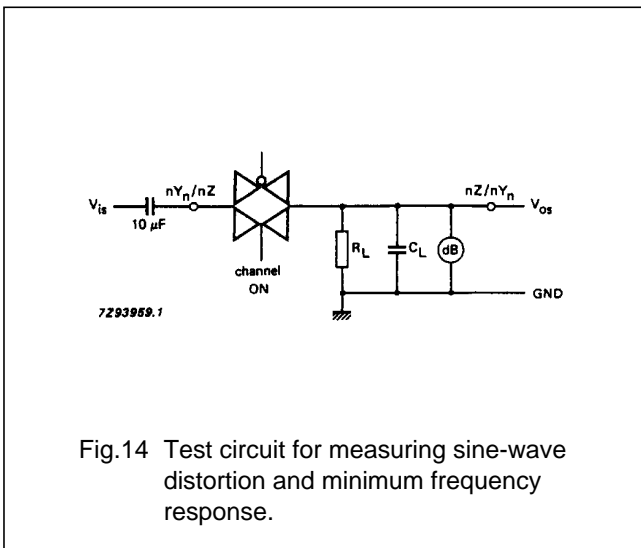
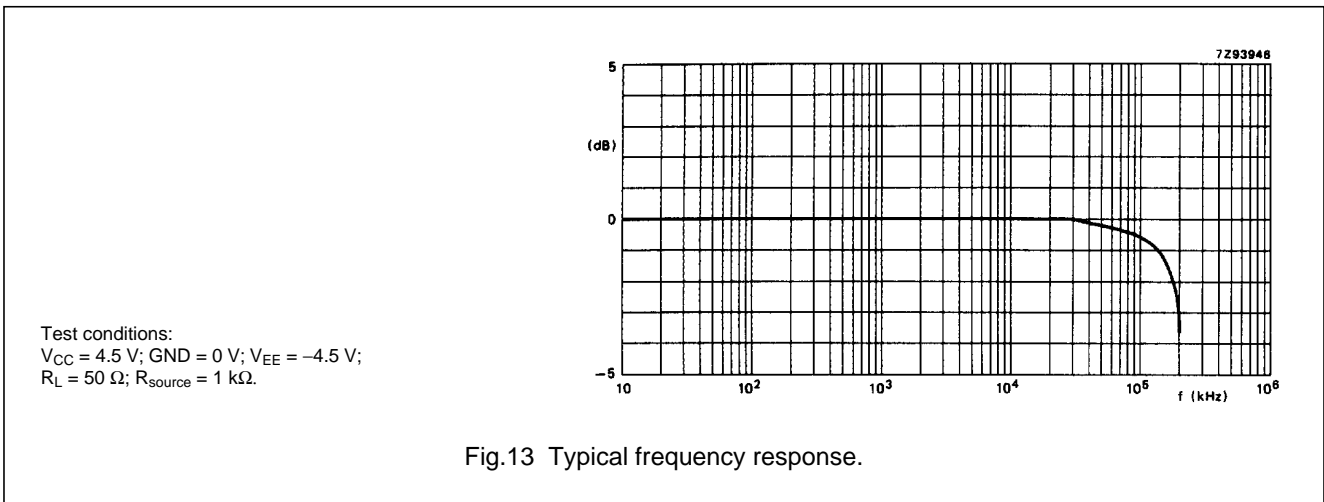
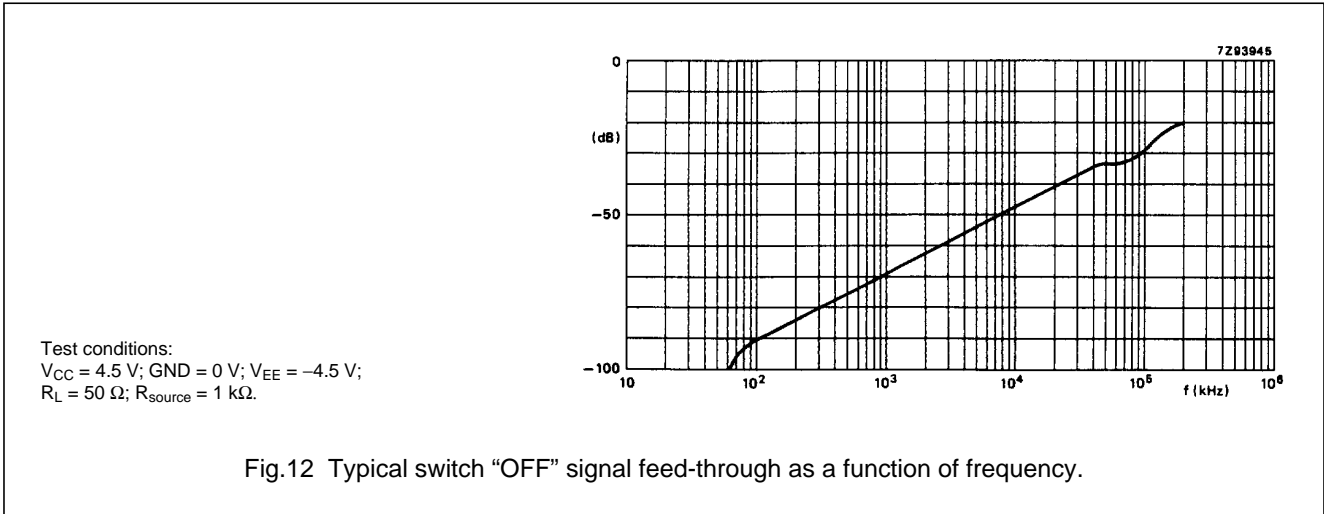

Triple 2-channel analog multiplexer/demultiplexer

74HC/HCT4053

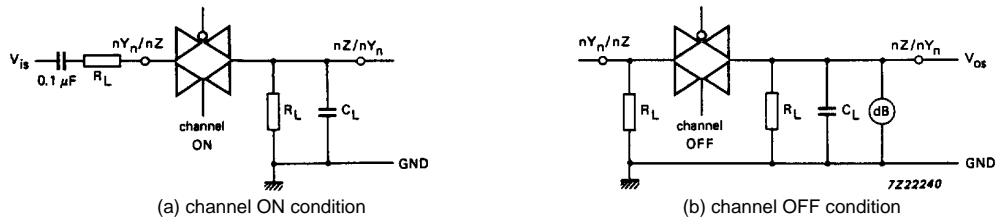

Fig.16 Test circuits for measuring crosstalk between any two switches/multiplexers.

The crosstalk is defined as follows (oscilloscope output):

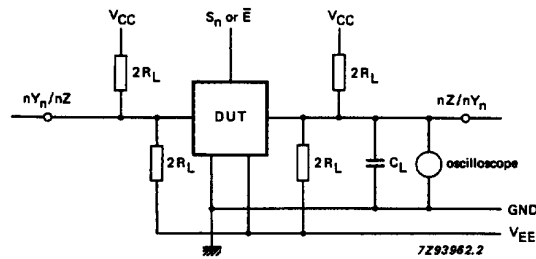
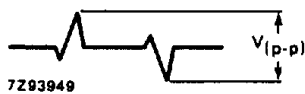

Fig.17 Test circuit for measuring crosstalk between control and any switch.

Triple 2-channel analog
multiplexer/demultiplexer

74HC/HCT4053

AC WAVEFORMS

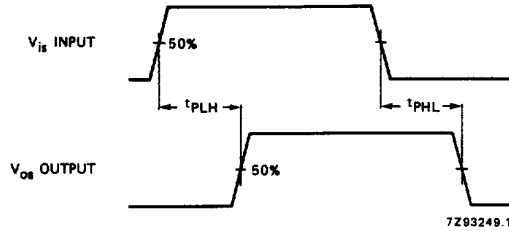
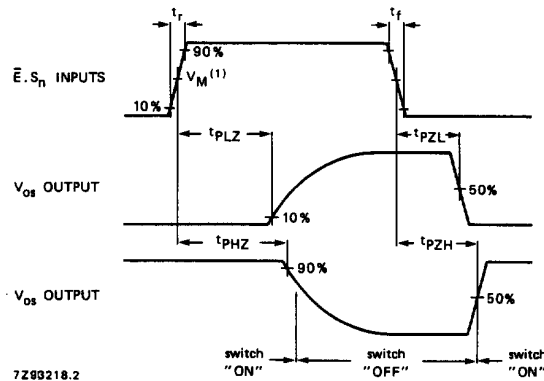

Fig.18 Waveforms showing the input (V_{is}) to output (V_{0s}) propagation delays.



(1) HC : $V_M = 50\%$; $V_I = \text{GND to } V_{CC}$.
HCT: $V_M = 1.3 V_I = \text{GND to } 3 \text{ V}$.

Fig.19 Waveforms showing the turn-ON and turn-OFF times.

Triple 2-channel analog multiplexer/demultiplexer

74HC/HCT4053

TEST CIRCUIT AND WAVEFORMS

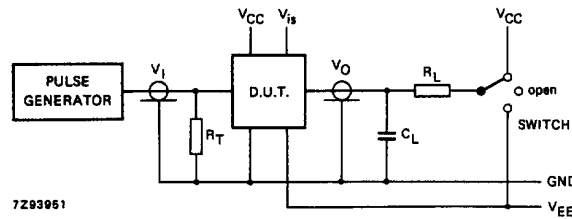

Conditions

TEST	SWITCH	V _{IS}
t _{PZH}	V _{EE}	V _{CC}
t _{PZL}	V _{CC}	V _{EE}
t _{PHZ}	V _{EE}	V _{CC}
t _{PLZ}	V _{CC}	V _{EE}
others	open	pulse

FAMILY	AMPLITUDE	V _M	t _r ; t _f	
			f _{max} ; PULSE WIDTH	OTHER
74HC	V _{CC}	50%	<2 ns	6 ns
74HCT	3.0 V	1.3 V	<2 ns	6 ns

C_L = load capacitance including jig and probe capacitance (see AC CHARACTERISTICS for values).

R_T = termination resistance should be equal to the output impedance Z_O of the pulse generator.

t_r = t_f = 6 ns; when measuring f_{max}, there is no constraint to t_r, t_f with 50% duty factor.

Fig.20 Test circuit for measuring AC performance.

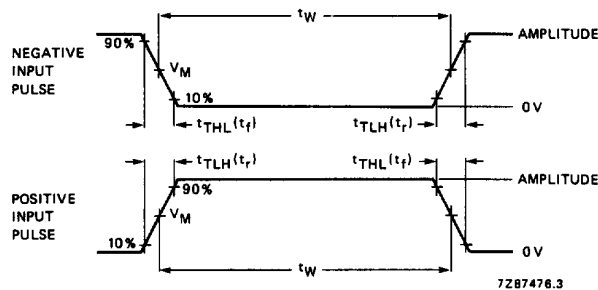

Conditions

TEST	SWITCH	V _{IS}
t _{PZH}	V _{EE}	V _{CC}
t _{PZL}	V _{CC}	V _{EE}
t _{PHZ}	V _{EE}	V _{CC}
t _{PLZ}	V _{CC}	V _{EE}
others	open	pulse

FAMILY	AMPLITUDE	V _M	t _r ; t _f	
			f _{max} ; PULSE WIDTH	OTHER
74HC	V _{CC}	50%	<2 ns	6 ns
74HCT	3.0 V	1.3 V	<2 ns	6 ns

C_L = load capacitance including jig and probe capacitance (see AC CHARACTERISTICS for values).

R_T = termination resistance should be equal to the output impedance Z_O of the pulse generator.

t_r = t_f = 6 ns; when measuring f_{max}, there is no constraint to t_r, t_f with 50% duty factor.

Fig.21 Input pulse definitions.

Triple 2-channel analog
multiplexer/demultiplexer

74HC/HCT4053

PACKAGE OUTLINES

See *"74HC/HCT/HCU/HCMOS Logic Package Outlines"*.