

54/7495A 54LS/74LS95B

4-BIT RIGHT/LEFT SHIFT REGISTER

DESCRIPTION — The '95 is a 4-bit shift register with serial and parallel synchronous operating modes. The serial shift right and parallel load are activated by separate clock inputs which are selected by a mode control input. The data is transferred from the serial or parallel D inputs to the Q outputs synchronous with the HIGH-to-LOW transition of the appropriate clock input.

- SYNCHRONOUS, EXPANDABLE SHIFT RIGHT
- SYNCHRONOUS SHIFT LEFT CAPABILITY
- SYNCHRONOUS PARALLEL LOAD
- SEPARATE SHIFT AND LOAD CLOCK INPUTS

ORDERING CODE: See Section 9

PKGS	PIN OUT	COMMERCIAL GRADE	MILITARY GRADE	PKG TYPE
		$V_{CC} = +5.0\text{ V} \pm 5\%$, $T_A = 0^\circ\text{C to } +70^\circ\text{C}$	$V_{CC} = +5.0\text{ V} \pm 10\%$, $T_A = -55^\circ\text{C to } +125^\circ\text{C}$	
Plastic DIP (P)	A	7495APC, 74LS95BPC		9A
Ceramic DIP (D)	A	7495ADC, 74LS95BDC	5495ADM, 54LS95BDM	6A
Flatpak (F)	A	7495AFC, 74LS95BFC	5495AFM, 54LS95BFM	3I

CONNECTION DIAGRAM PINOUT A

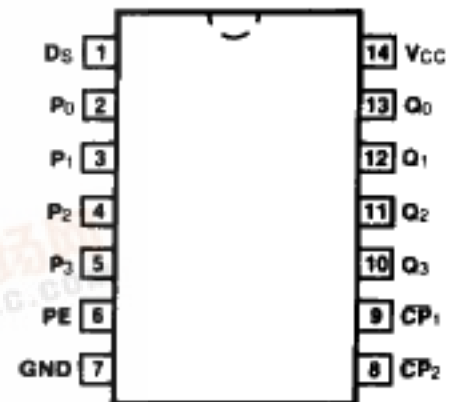

LOGIC SYMBOL

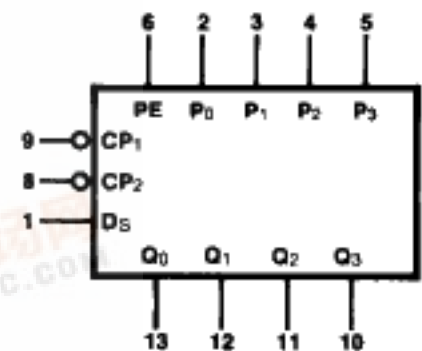

$V_{CC} = \text{Pin } 14$
 $GND = \text{Pin } 7$

INPUT LOADING/FAN-OUT: See Section 3 for U.L. definitions

PIN NAMES	DESCRIPTION	54/74 (U.L.) HIGH/LOW	54/74LS (U.L.) HIGH/LOW
\overline{CP}_1	Serial Clock Input (Active Falling Edge)	1.0/1.0	0.5/0.25
\overline{CP}_2	Parallel Clock Input (Active Falling Edge)	1.0/1.0	0.5/0.25
D_s	Serial Data Input	1.0/1.0	0.5/0.25
$P_0 - P_3$	Parallel Data Inputs	1.0/1.0	0.5/0.25
PE	Parallel Enable Input (Active HIGH)	2.0/2.0	1.0/0.5
$Q_0 - Q_3$	Parallel Outputs	20/10	10/5.0 (2.5)

FUNCTIONAL DESCRIPTION — The '95 is a 4-bit shift register with serial and parallel synchronous operating modes. It has a Serial (D_S) and four Parallel ($P_0 - P_3$) Data inputs and four Parallel Data outputs ($Q_0 - Q_3$). The serial or parallel mode of operation is controlled by a Parallel Enable input (PE) and two Clock inputs, \overline{CP}_1 and \overline{CP}_2 . The serial (right-shift) or parallel data transfers occur synchronous with the HIGH-to-LOW transition of the selected clock input.

When PE is HIGH, \overline{CP}_2 is enabled. A HIGH-to-LOW transition on enabled \overline{CP}_2 transfers parallel data from the $P_0 - P_3$ inputs to the $Q_0 - Q_3$ outputs. When PE is LOW, \overline{CP}_1 is enabled. A HIGH-to-LOW transition on enabled \overline{CP}_1 transfers the data from Serial input (D_S) to Q_0 and shifts the data in Q_0 to Q_1 , Q_1 to Q_2 , and Q_2 to Q_3 respectively (right-shift). A left-shift is accomplished by externally connecting Q_3 to P_2 , Q_2 to P_1 , and Q_1 to P_0 , and operating the '95 in the parallel mode (PE = HIGH). For normal operation, PE should only change states when both Clock inputs are LOW. However, changing PE from LOW to HIGH while \overline{CP}_2 is HIGH, or changing PE from HIGH to LOW while \overline{CP}_1 is HIGH and \overline{CP}_2 is LOW will not cause any changes on the register outputs.

MODE SELECT TABLE

OPERATING MODE	INPUTS					OUTPUTS			
	PE	\overline{CP}_1	\overline{CP}_2	D_S	P_n	Q_0	Q_1	Q_2	Q_3
Shift	L	L	X	l	X	L	q ₀	q ₁	q ₂
	L	L	X	h	X	H	q ₀	q ₁	q ₂
Parallel Load	H	X	L	X	p _n	p ₀	p ₁	p ₂	p ₃
Mode Change	L	L	L	X	X	No Change			
	L	L	L	X	X	No Change			
	L	H	L	X	X	No Change			
	L	H	L	X	X	Undetermined			
	L	L	H	X	X	Undetermined			
	L	L	H	X	X	No Change			
	L	H	H	X	X	Undetermined			
	L	H	H	X	X	No Change			

l = LOW Voltage Level one set-up time prior to the HIGH-to-LOW clock transition.
 h = HIGH Voltage Level one set-up time prior to the HIGH-to-LOW clock transition.
 p_n = Lower case letters indicate the state of the referenced input (or output) one set-up time prior to the HIGH-to-LOW clock transition.

H = HIGH Voltage Level
 L = LOW Voltage Level
 X = Immaterial

LOGIC DIAGRAM

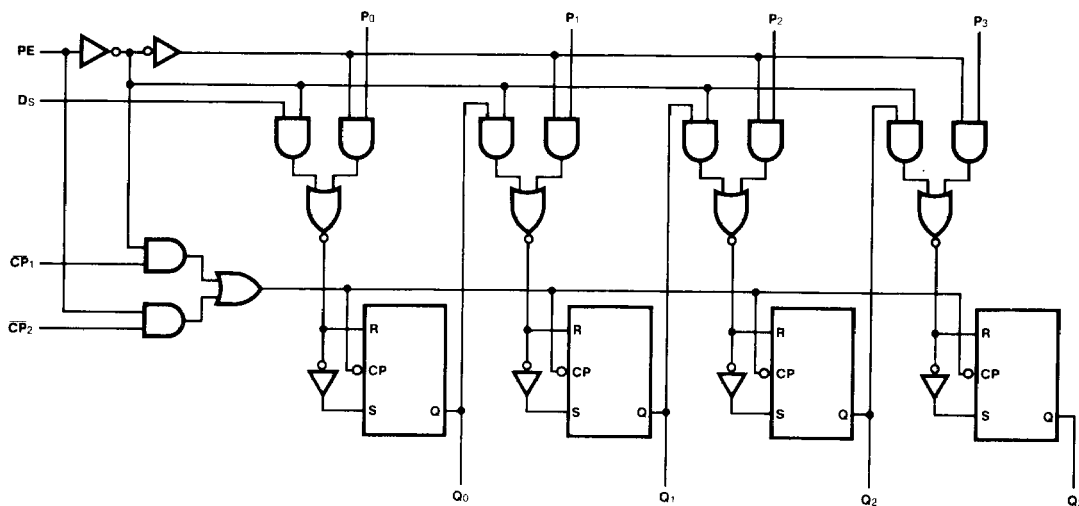

DC CHARACTERISTICS OVER OPERATING TEMPERATURE RANGE (unless otherwise specified)

SYMBOL	PARAMETER	54/74		54/74LS		UNITS	CONDITIONS
		Min	Max	Min	Max		
I_{CC}	Power Supply Current	63		21		mA	$V_{CC} = \text{Max}$

AC CHARACTERISTICS: $V_{CC} = +5.0 \text{ V}$, $T_A = +25^\circ \text{ C}$ (See Section 3 for waveforms and load configurations)

SYMBOL	PARAMETER	54/74		54/74LS		UNITS	CONDITONS
		$C_L = 15 \text{ pF}$ $R_L = 400 \Omega$		$C_L = 15 \text{ pF}$			
		Min	Max	Min	Max		
f_{max}	Maximum Shift Frequency	25		30		MHz	Figs. 3-1, 3-9
t_{PLH} t_{PHL}	Propagation Delay \overline{CP}_1 or \overline{CP}_2 to Q_n	27 32		27 27		ns	Figs. 3-1, 3-9

AC OPERATING REQUIREMENTS: $V_{CC} = +5.0 \text{ V}$, $T_A = +25^\circ \text{ C}$

SYMBOL	PARAMETER	54/74		54/74LS		UNITS	CONDITIONS
		Min	Max	Min	Max		
t_s (H) t_s (L)	Setup Time HIGH or LOW D_s or P_n to \overline{CP}_n	15		20		ns	Fig. 3-7
t_h (H) t_h (L)	Hold Time HIGH or LOW D_s or P_n to \overline{CP}_n	0		10		ns	Fig. 3-7
t_w (H)	\overline{CP}_n Pulse Width HIGH	20		20		ns	Fig. 3-9
t_{en} (L)	Enable Time LOW PE to \overline{CP}_1	15		25		ns	Fig. a
t_{inh} (H)	Inhibit Time HIGH PE to \overline{CP}_1	5.0		20		ns	Fig. a
t_{en} (H)	Enable Time HIGH PE to \overline{CP}_2	15		25		ns	Fig. a
t_{inh} (L)	Inhibit Time LOW PE to \overline{CP}_2	5.0		20		ns	Fig. a

