

November 1994

54F/74F04 Hex Inverter

General Description

This device contains six independent gates, each of which performs the logic INVERT function.

Features

- Guaranteed 4000V minimum ESD protection

Ordering Code: See Section 0

Commercial	Military	Package Number	Package Description
74F04PC		N14A	14-Lead (0.300" Wide) Molded Dual-In-Line
	54F04DM (Note 2)	J14A	14-Lead Ceramic Dual-In-Line
74F04SC (Note 1)		M14A	14-Lead (0.150" Wide) Molded Small Outline, JEDEC
74F04SJ (Note 1)		M14D	14-Lead (0.300" Wide) Molded Small Outline, EIAJ
	54F04FM (Note 2)	W14B	14-Lead Cerpack
	54F04LM (Note 2)	E20A	20-Lead Ceramic Leadless Chip Carrier, Type C

Note 1: Devices also available in 13" reel. Use suffix = SCX and SJX.

Note 2: Military grade device with environmental and burn-in processing. Use suffix = DMQB, FMQB and LMQB.

Logic Symbol

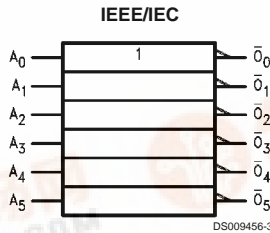

Connection Diagrams

Pin Assignment for
DIP, SOIC and Flatpak

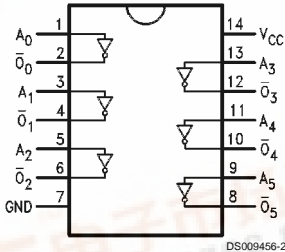

Pin Assignment
for LCC

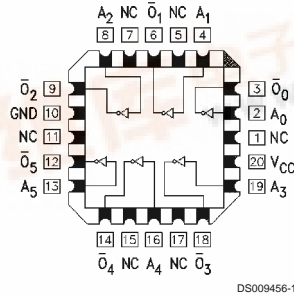

TRI-STATE® is a registered trademark of National Semiconductor Corporation.

Unit Loading/Fan Out

See Section 0 for U.L. definitions

DSXXX

Pin Names	Description	54F74F	
		U.L. HIGH/LOW	Input I_{IH}/I_{IL} Output I_{OH}/I_{OL}
A_n	Inputs	1.0/1.0	20 μ A/-0.6 mA
\bar{O}_n	Outputs	50/33.3	-1 mA/20 mA

Absolute Maximum Ratings (Note 3)

If Military/Aerospace specified devices are required, please contact the National Semiconductor Sales Office/Distributors for availability and specifications.

Storage Temperature	-65°C to +150°C
Ambient Temperature under Bias	-55°C to +125°C
Junction Temperature under Bias	-55°C to +175°C
Plastic	-55°C to +150°C
V _{CC} Pin Potential to Ground Pin	-0.5V to +7.0V
Input Voltage (Note 4)	-0.5V to +7.0V
Input Current (Note 4)	-30 mA to +5.0 mA
Voltage Applied to Output in HIGH State (with V _{CC} = 0V)	
Standard Output	-0.5V to V _{CC}
TRI-STATE® Output	-0.5V to +5.5V

Current Applied to Output in LOW State (Max) twice the rated I_{OL} (mA)
ESD Last Passing Voltage (Min) 4000V

Recommended Operating Conditions

Free Air Ambient Temperature	
Military	-55°C to +125°C
Commercial	0°C to +70°C
Supply Voltage	
Military	+4.5V to +5.5V
Commercial	+4.5V to +5.5V

Note 3: Absolute maximum ratings are values beyond which the device may be damaged or have its useful life impaired. Functional operation under these conditions is not implied.

Note 4: Either voltage limit or current limit is sufficient to protect inputs.

DC Electrical Characteristics

Symbol	Parameter	54F/74F			Units	V _{CC}	Conditions
		Min	Typ	Max			
V _{IH}	Input HIGH Voltage	2.0			V		Recognized as a HIGH Signal
V _{IL}	Input LOW Voltage				V		Recognized as a LOW Signal
V _{CD}	Input Clamp Diode Voltage				V	Min	I _{IN} = -18 mA
V _{OH}	Output HIGH Voltage	54F 10% V _{CC}	2.5		V	Min	I _{OH} = -1 mA
		74F 10% V _{CC}	2.5				I _{OH} = -1 mA
		74F 5% V _{CC}	2.7				I _{OH} = -1 mA
V _{OL}	Output LOW Voltage	54F 10% V _{CC}	0.5		V	Min	I _{OL} = 20 mA
		74F 10% V _{CC}	0.5				I _{OL} = 20 mA
I _{IH}	Input HIGH Current	54F	20.0		μA	Max	V _{IN} = 2.7V
		74F	5.0				
I _{BVI}	Input HIGH Current Breakdown Test	54F	100		μA	Max	V _{IN} = 7.0V
		74F	7.0				
I _{CEX}	Output HIGH Leakage Current	54F	250		μA	Max	V _{OUT} = V _{CC}
		74F	50				
V _{ID}	Input Leakage Test	74F	4.75		V	0.0	I _{ID} = 1.9 μA All other pins grounded
I _{OD}	Output Leakage Circuit Current	74F	3.75		μA	0.0	V _{IOD} = 150 mV All other pins grounded
I _{IL}	Input LOW Current				mA	Max	V _{IN} = 0.5V
I _{OS}	Output Short-Circuit Current	-60	-150		mA	Max	V _{OUT} = 0V
I _{CCH}	Power Supply Current	2.8 4.2			mA	Max	V _O = HIGH
I _{CCL}	Power Supply Current	10.2 15.3			mA	Max	V _O = LOW

AC Electrical Characteristics

See Section 0 for Waveforms and Load Configurations

Symbol	Parameter	74F			54F		74F		Units	Fig. No.
		T _A = +25°C V _{CC} = +5.0V C _L = 50 pF			T _A , V _{CC} = Mil C _L = 50 pF		T _A , V _{CC} = Com C _L = 50 pF			
		Min	Typ	Max	Min	Max	Min	Max		
t _{PLH}	Propagation Delay	2.4	3.7	5.0	2.0	7.0	2.4	6.0	ns	◆◆◆◆
t _{PHL}	A _n to \bar{O}_n	1.5	3.2	4.3	1.5	6.5	1.5	5.3		

THIS PAGE IS IGNORED IN THE DATABOOK

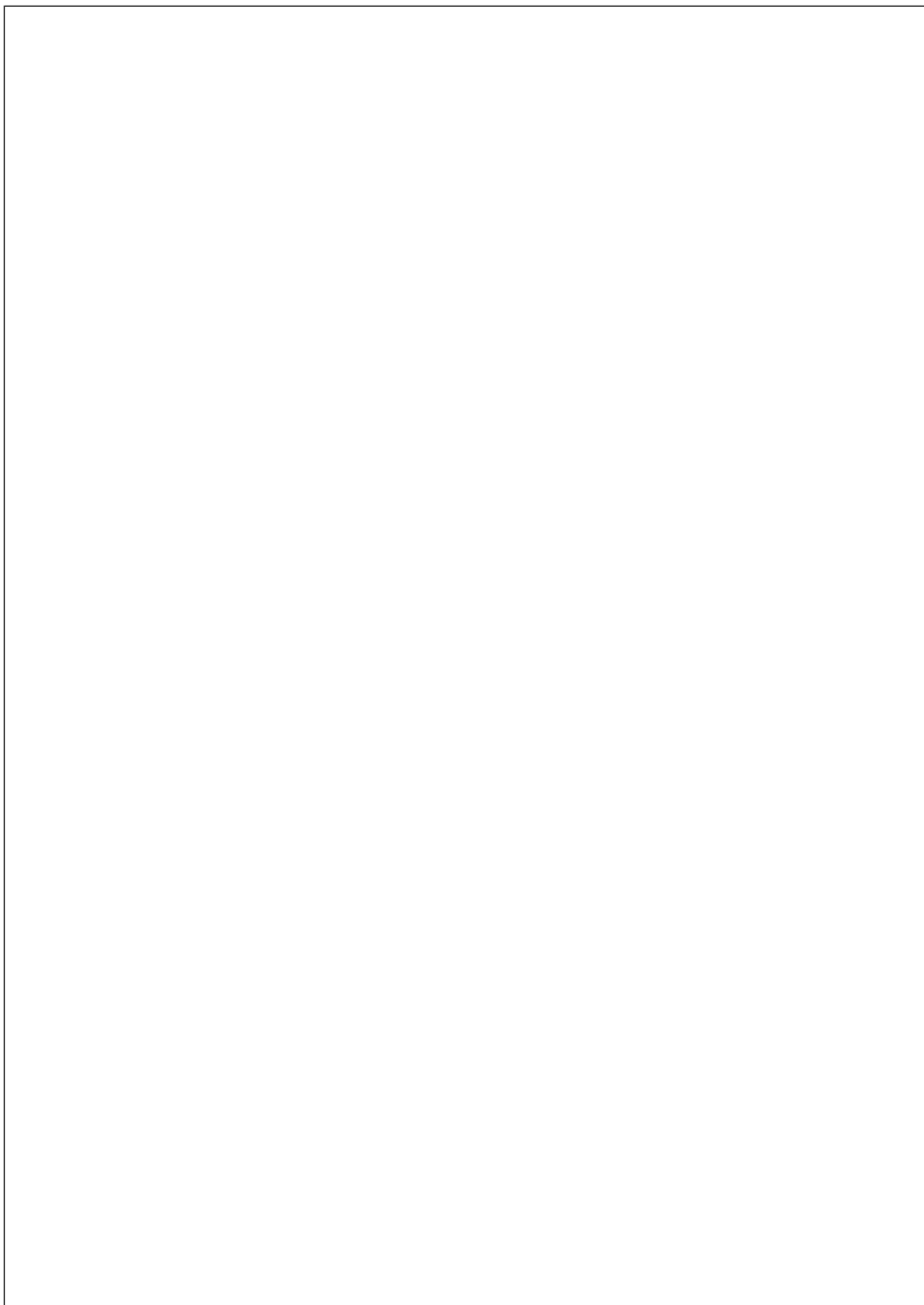

Ordering Information

The device number is used to form part of a simplified purchasing code where the package type and temperature range are defined as follows:

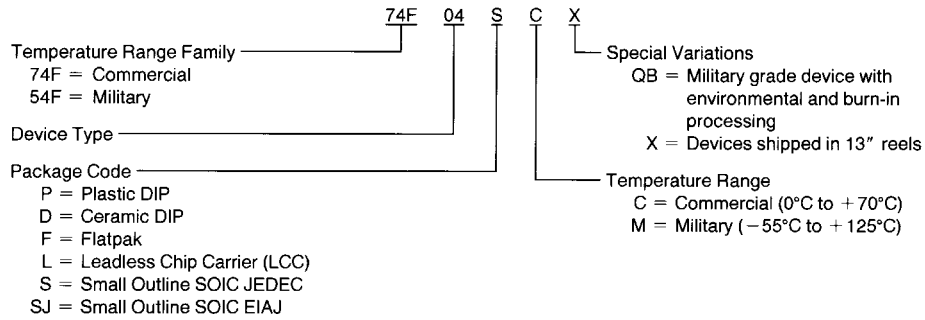

DS009456-4

Physical Dimensions inches (millimeters) unless otherwise noted

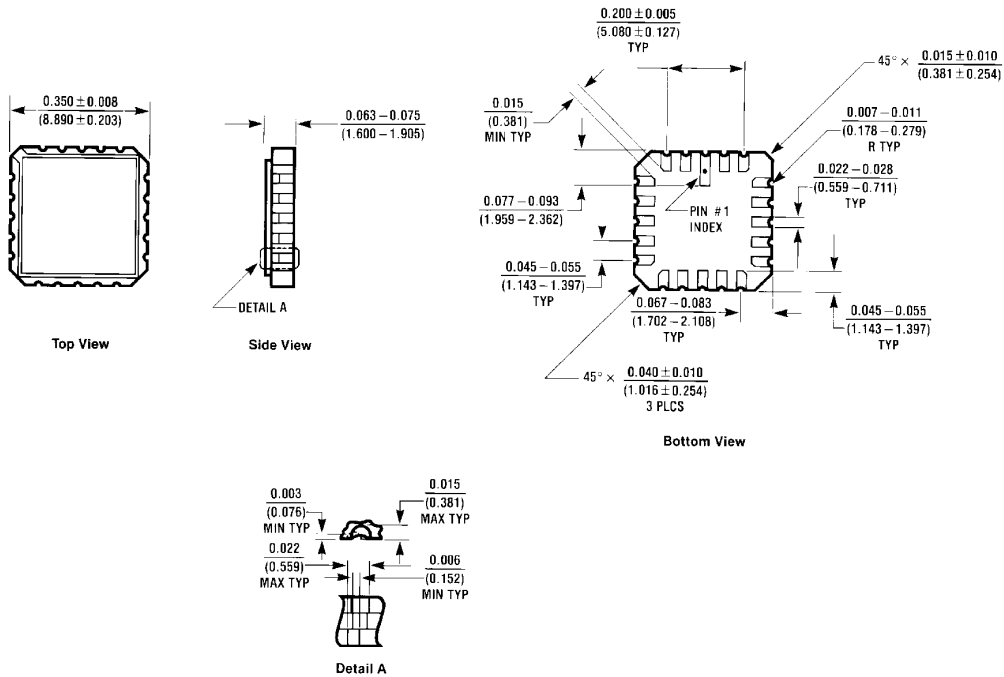

E20A (REV. 01)

**20-Terminal Ceramic Leadless Chip Carrier (L)
 NS Package Number E20A**

Physical Dimensions inches (millimeters) unless otherwise noted (Continued)

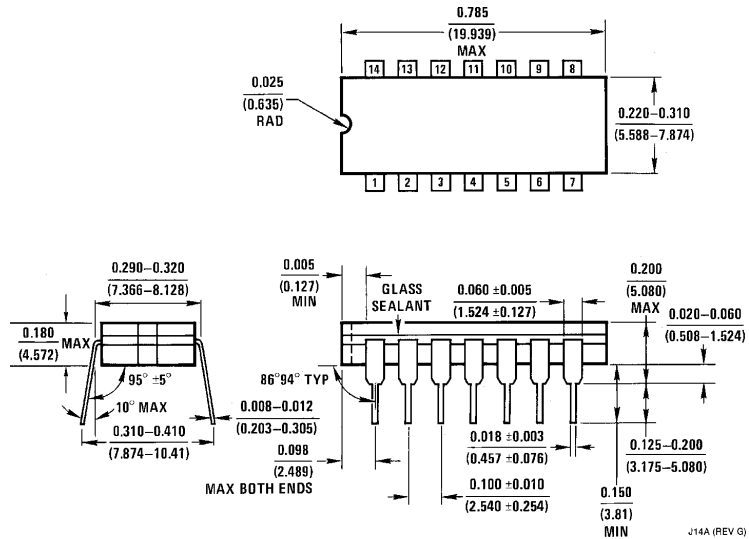

14-Lead Ceramic Dual-In-Line Package (D)
NS Package Number J14A

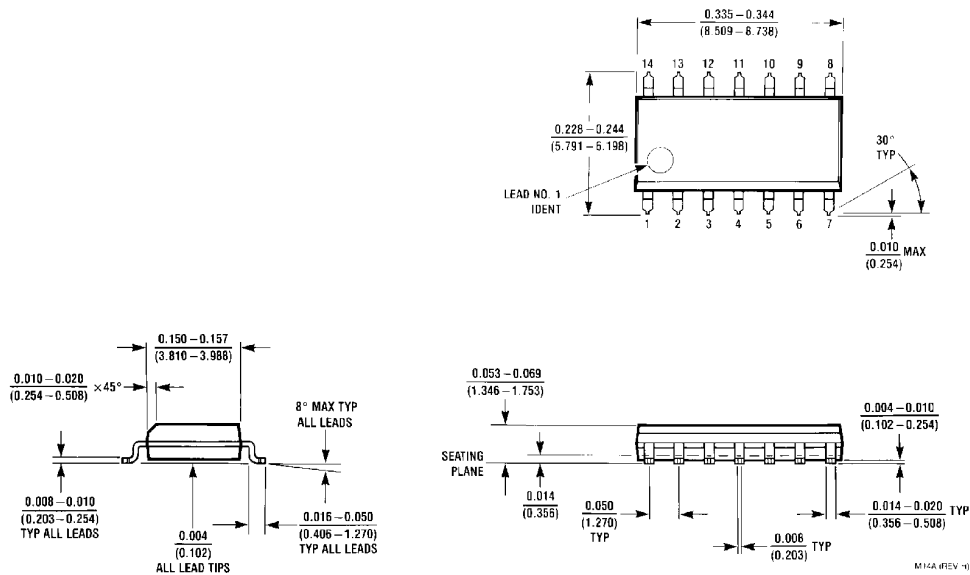

14-Lead (0.150" Wide) Molded Small Outline Package, JEDEC (S)
NS Package Number M14A

Physical Dimensions inches (millimeters) unless otherwise noted (Continued)

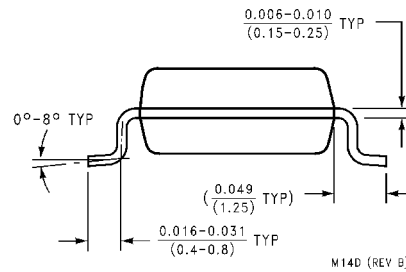
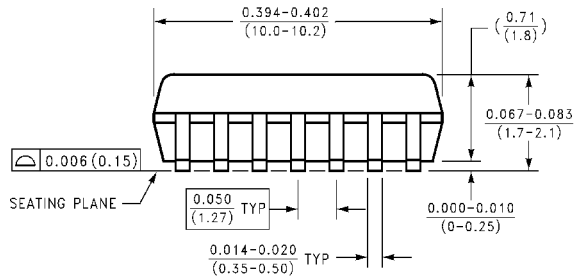
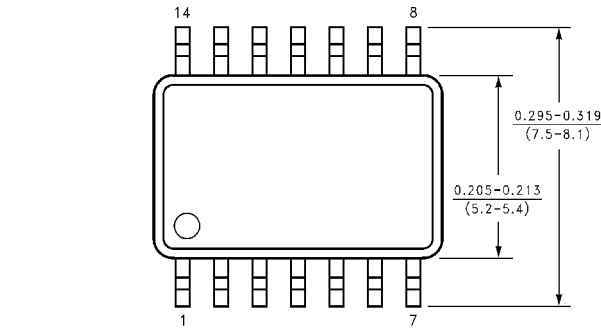

**14-Lead (0.300" Wide) Molded Small Outline Package, EIAJ (SJ)
NS Package Number M14D**

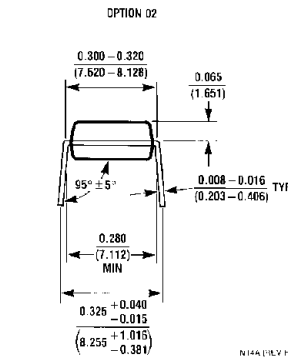
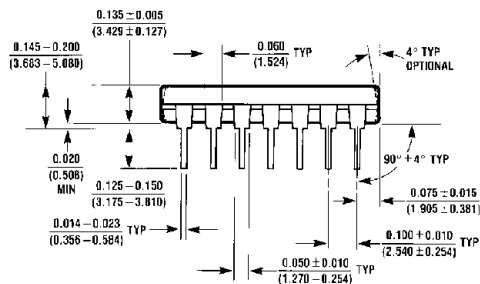
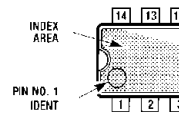
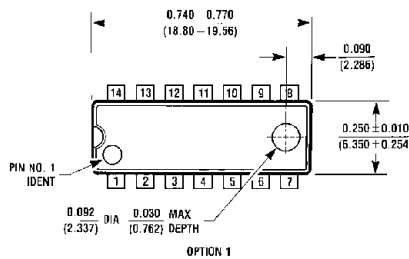

**14-Lead (0.300" Wide) Molded Dual-In-Line Package (P)
NS Package Number N14A**

Physical Dimensions inches (millimeters) unless otherwise noted (Continued)

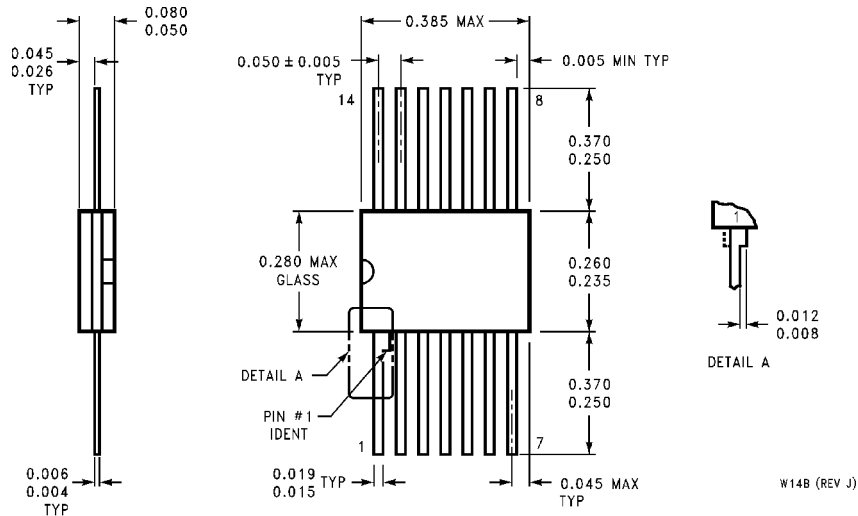

**14-Lead Ceramic Flatpak (F)
NS Package Number W14B**

LIFE SUPPORT POLICY

NATIONAL'S PRODUCTS ARE NOT AUTHORIZED FOR USE AS CRITICAL COMPONENTS IN LIFE SUPPORT DEVICES OR SYSTEMS WITHOUT THE EXPRESS WRITTEN APPROVAL OF THE PRESIDENT OF NATIONAL SEMICONDUCTOR CORPORATION. As used herein:

1. Life support devices or systems are devices or systems which, (a) are intended for surgical implant into the body, or (b) support or sustain life, and whose failure to perform when properly used in accordance with instructions for use provided in the labeling, can be reasonably expected to result in a significant injury to the user.
2. A critical component in any component of a life support device or system whose failure to perform can be reasonably expected to cause the failure of the life support device or system, or to affect its safety or effectiveness.

 <p>National Semiconductor Corporation Americas Tel: 1-800-272-9959 Fax: 1-800-737-7018 Email: support@nsc.com</p> <p>www.national.com</p>	<p>National Semiconductor Europe Fax: +49 (0) 1 80-530 85 86 Email: europe.support@nsc.com Deutsch Tel: +49 (0) 1 80-530 85 85 English Tel: +49 (0) 1 80-532 78 32 Français Tel: +49 (0) 1 80-532 93 58 Italiano Tel: +49 (0) 1 80-534 16 80</p>	<p>National Semiconductor Hong Kong Ltd. 13th Floor, Straight Block, Ocean Centre, 5 Canton Rd. Tsimshatsui, Kowloon Hong Kong Tel: (852) 2737-1600 Fax: (852) 2736-9960</p>	<p>National Semiconductor Japan Ltd. Tel: 81-3-5620-6175 Fax: 81-3-5620-6179</p>
--	---	---	---

National does not assume any responsibility for use of any circuitry described, no circuit patent licenses are implied and National reserves the right at any time without notice to change said circuitry and specifications.