

# SN54LS07, SN74LS07, SN74LS17 HEX BUFFERS/DRIVERS WITH OPEN-COLLECTOR HIGH-VOLTAGE OUTPUTS

SDLS021A, D3517, MAY 1990—REVISED AUGUST 1991

- **Converts TTL-Voltage Levels to MOS Levels**
- **High Sink-Current Capability**
- **Input Clamping Diodes Simplify System Design**
- **Open-Collector Driver for Indicator Lamps and Relays**
- **Package Options Include “Small Outline” Packages, Ceramic Chip Carriers, and Standard and Ceramic 300-mil DIPs**

## description

These monolithic hex buffers/drivers feature high-voltage open-collector outputs to interface with high-level circuits or for driving high-current loads. They are also characterized for use as buffers for driving TTL inputs. The 'LS07 has a rated output voltage of 30 V and the 'LS17 has a rated output voltage of 15 V. The maximum sink current is 30 mA for the SN54LS07 and 40 mA for the SN74LS07 and SN74LS17.

These circuits are compatible with most TTL families. Inputs are diode-clamped to minimize transmission-line effects, which simplifies design. Typical power dissipation is 140 mW and average propagation delay time is 12 ns.

The SN54LS07 is characterized over the full military temperature range of  $-55^{\circ}\text{C}$  to  $125^{\circ}\text{C}$ . The SN74LS07 and SN74LS17 are characterized for operation from  $0^{\circ}\text{C}$  to  $70^{\circ}\text{C}$ .

## logic symbol†

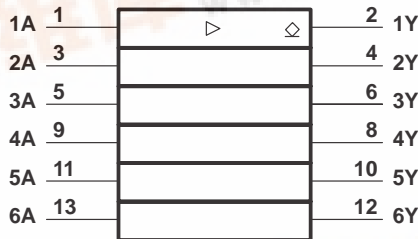

† This symbol is in accordance with ANSI/IEEE Std 91-1984 and IEC Publication 617-12. Pin numbers shown are for D, J, and N packages.

SN54LS07 . . . J PACKAGE  
SN74LS07, SN74LS17 . . . D OR N PACKAGE  
(TOP VIEW)

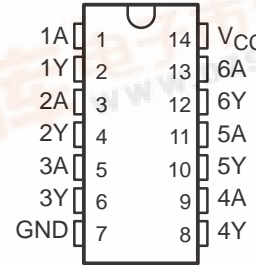

SN54LS07 . . . FK PACKAGE  
(TOP VIEW)

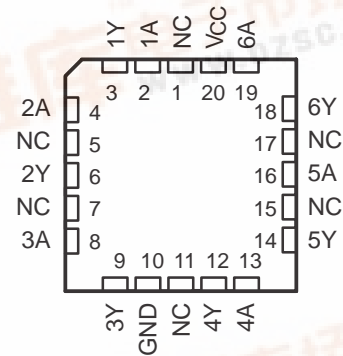

NC – No internal connection

## logic diagram (positive logic)

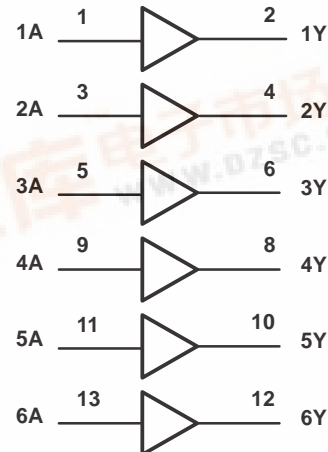

# SN54LS07, SN74LS07, SN74LS17 HEX BUFFERS/DRIVERS WITH OPEN-COLLECTOR HIGH-VOLTAGE OUTPUTS

## schematic (each gate)

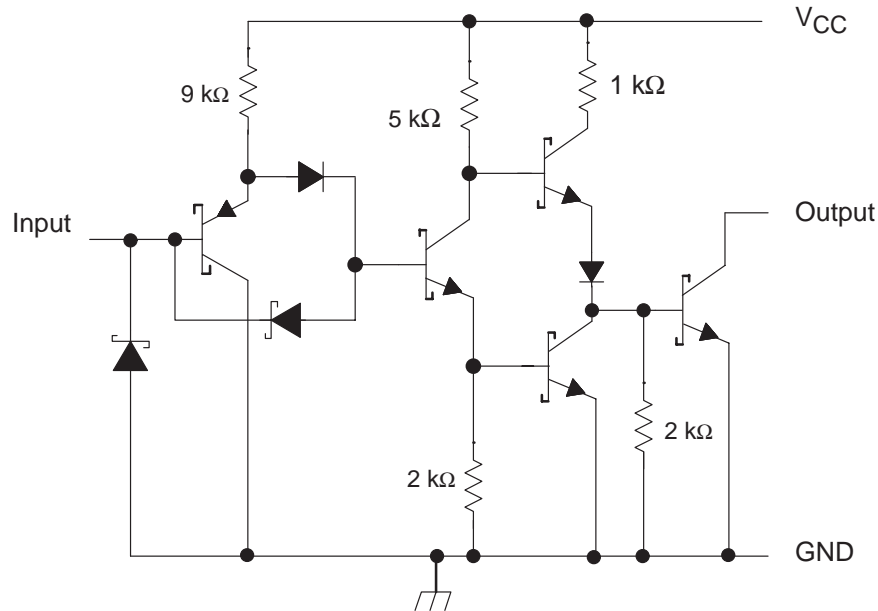

Resistor values shown are nominal.

## absolute maximum ratings over operating free-air temperature range (unless otherwise noted)<sup>†</sup>

Supply voltage, $V_{CC}$	7 V
Input voltage, $V_I$ (see Note 1)	5.5 V
Output voltage, $V_O$ (see Notes 1 and 2): SN54LS07, SN74LS07	30 V
SN74LS17	15 V
Operating free-air temperature range: SN54LS07	-55°C to 125°C
SN54LS07, SN74LS17	0°C to 70°C
Storage temperature range	-65°C to 150°C

<sup>†</sup> Stresses beyond those listed under "absolute maximum ratings" may cause permanent damage to the device. These are stress ratings only, and functional operation of the device at these or any other conditions beyond those indicated under "recommended operating conditions" is not implied. Exposure to absolute-maximum-rated conditions for extended periods may affect device reliability.

NOTES: 1. Voltage values are with respect to network ground terminal.

2. This is the maximum voltage that should be applied to any output when it is in the off state.

## recommended operating conditions

		SN54LS07			SN74LS07 SN74LS17			UNIT
		MIN	NOM	MAX	MIN	NOM	MAX	
$V_{CC}$	Supply voltage	4.5	5	5.5	4.75	5	5.25	V
$V_{IH}$	High-level input voltage	2			2			V
$V_{IL}$	Low-level input voltage			0.8			0.8	V
$V_{OH}$	High-level output voltage			30			30	V
							15	
$I_{OL}$	Low-level output current			30			40	mA
$T_A$	Operating free-air temperature	-55		125	0		70	°C

**SN54LS07, SN74LS07, SN74LS17**  
**HEX BUFFERS/DRIVERS WITH**  
**OPEN-COLLECTOR HIGH-VOLTAGE OUTPUTS**

**electrical characteristics over recommended operating free-air temperature range (unless otherwise noted)**

PARAMETER	TEST CONDITIONS†		SN54LS07			SN74LS07 SN74LS17			UNIT
			MIN	TYP‡	MAX	MIN	TYP‡	MAX	
$V_{IK}$	$V_{CC} = \text{MIN}$ ,	$I_I = -12 \text{ mA}$			-1.5			-1.5	V
$I_{OH}$	$V_{CC} = \text{MIN}$ ,	$V_{IH} = 2 \text{ V}$	'LS07, $V_{OH} = 30 \text{ V}$			0.25			mA
			'LS17, $V_{OH} = 15 \text{ V}$			0.25			
$V_{OL}$	$V_{CC} = \text{MIN}$ ,	$V_{IL} = 0.8 \text{ V}$	$I_{OL} = 16 \text{ mA}$			0.4			V
			$I_{OL} = \text{MAX}^{\S}$			0.7			
$I_I$	$V_{CC} = \text{MAX}$ ,	$V_I = 7 \text{ V}$			1			1	mA
$I_{IH}$	$V_{CC} = \text{MAX}$ ,	$V_I = 2.4 \text{ V}$			20			20	$\mu\text{A}$
$I_{IL}$	$V_{CC} = \text{MAX}$ ,	$V_I = 0.4 \text{ V}$			-0.2			-0.2	mA
$I_{CCH}$	$V_{CC} = \text{MAX}$				14			14	mA
$I_{CCL}$	$V_{CC} = \text{MAX}$				45			45	mA

† For conditions shown as MIN or MAX, use the appropriate value specified under recommended operating conditions.

‡ All typical values are at  $V_{CC} = 5 \text{ V}$ ,  $T_A = 25^\circ\text{C}$ .

§  $I_{OL} = 30 \text{ mA}$  for SN54 series parts and  $40 \text{ mA}$  for SN74 series parts.

**switching characteristics,  $V_{CC} = 5 \text{ V}$ ,  $T_A = 25^\circ\text{C}$  (see Note 3)**

PARAMETER	FROM (INPUT)	TO (OUTPUT)	TEST CONDITIONS			MIN	TYP	MAX	UNIT
$t_{PLH}$	A	Y	$R_L = 110 \Omega$ , $C_L = 15 \text{ pF}$				6	10	ns
$t_{PHL}$							19	30	

NOTE 3: Load circuit and voltage waveforms are shown in Section 1 of *TTL Logic Data Book*, 1988.

## **IMPORTANT NOTICE**

Texas Instruments and its subsidiaries (TI) reserve the right to make changes to their products or to discontinue any product or service without notice, and advise customers to obtain the latest version of relevant information to verify, before placing orders, that information being relied on is current and complete. All products are sold subject to the terms and conditions of sale supplied at the time of order acknowledgement, including those pertaining to warranty, patent infringement, and limitation of liability.

TI warrants performance of its semiconductor products to the specifications applicable at the time of sale in accordance with TI's standard warranty. Testing and other quality control techniques are utilized to the extent TI deems necessary to support this warranty. Specific testing of all parameters of each device is not necessarily performed, except those mandated by government requirements.

CERTAIN APPLICATIONS USING SEMICONDUCTOR PRODUCTS MAY INVOLVE POTENTIAL RISKS OF DEATH, PERSONAL INJURY, OR SEVERE PROPERTY OR ENVIRONMENTAL DAMAGE ("CRITICAL APPLICATIONS"). TI SEMICONDUCTOR PRODUCTS ARE NOT DESIGNED, AUTHORIZED, OR WARRANTED TO BE SUITABLE FOR USE IN LIFE-SUPPORT DEVICES OR SYSTEMS OR OTHER CRITICAL APPLICATIONS. INCLUSION OF TI PRODUCTS IN SUCH APPLICATIONS IS UNDERSTOOD TO BE FULLY AT THE CUSTOMER'S RISK.

In order to minimize risks associated with the customer's applications, adequate design and operating safeguards must be provided by the customer to minimize inherent or procedural hazards.

TI assumes no liability for applications assistance or customer product design. TI does not warrant or represent that any license, either express or implied, is granted under any patent right, copyright, mask work right, or other intellectual property right of TI covering or relating to any combination, machine, or process in which such semiconductor products or services might be or are used. TI's publication of information regarding any third party's products or services does not constitute TI's approval, warranty or endorsement thereof.