

# DUAL-OUTPUT LOW-INPUT-VOLTAGE DSP POWER SUPPLY CONTROLLER WITH SEQUENCING

SLVS289 – MARCH 2000

- **2.8 V – 5.5 V Input Voltage Range**
- **Programmable Dual Output Controller Supports Popular DSP, FPGA and Microcontroller Core and I/O Voltages**
  - Switching Regulator Controls I/O Voltage
  - Low Dropout Controller Regulates Core Voltage
- **Adjustable Slow-Start for Simultaneous Powerup of Both Outputs**
- **Power Good Output Monitors Both Outputs**
- **Fast Ripple Regulator Reduces Bulk Capacitance for Lower System Costs**
- **±1.5% Reference Voltage Tolerance**
- **Efficiencies Greater Than 90%**
- **Overvoltage, Undervoltage, and Adjustable Overcurrent Protection**
- **Drives Logic Level N-Channel MOSFETs Through Entire Input Voltage Range**
- **Evaluation Module TPS56302EVM–163 Available**

**PWP PowerPAD™ PACKAGE (TOP VIEW)**

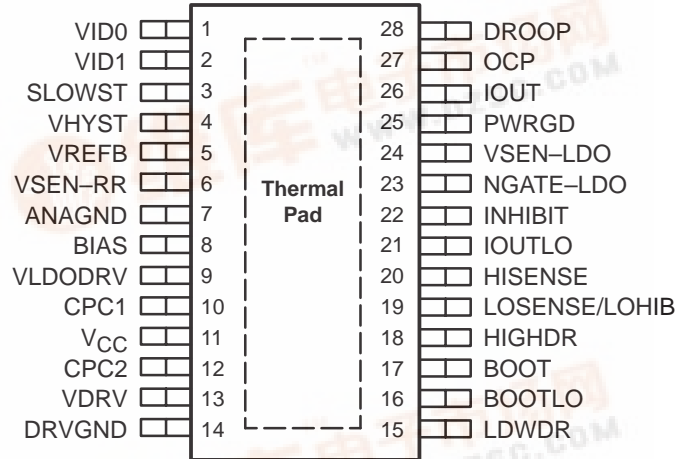

**AVAILABLE VID CODE RANGES**

OUTPUTS	TPS56302	TPS56300
V <sub>OUT</sub> -LDO	1.3 V TO 2.5 V	1.3 V TO 3.3 V
V <sub>OUT</sub> -Switcher	1.3 V TO 3.3 V	1.3 V TO 2.5 V

NOTE: See Table 1 for actual VID codes.

## description

The high-performance TPS56302 synchronous-buck regulator provides two supply voltages to power the core and I/O of digital signal processors. The TPS56302 is identical to the TPS56300 except that the reference voltages of the LDO and switching regulator have been reversed. The switching regulator, using hysteretic control with droop compensation, supports high current and efficiency for the I/O and other peripheral components. The LDO controller, suitable for powering the core voltage, drives an external N-channel power MOSFET and functions as an LDO regulator and as a power distribution switch.

## typical design

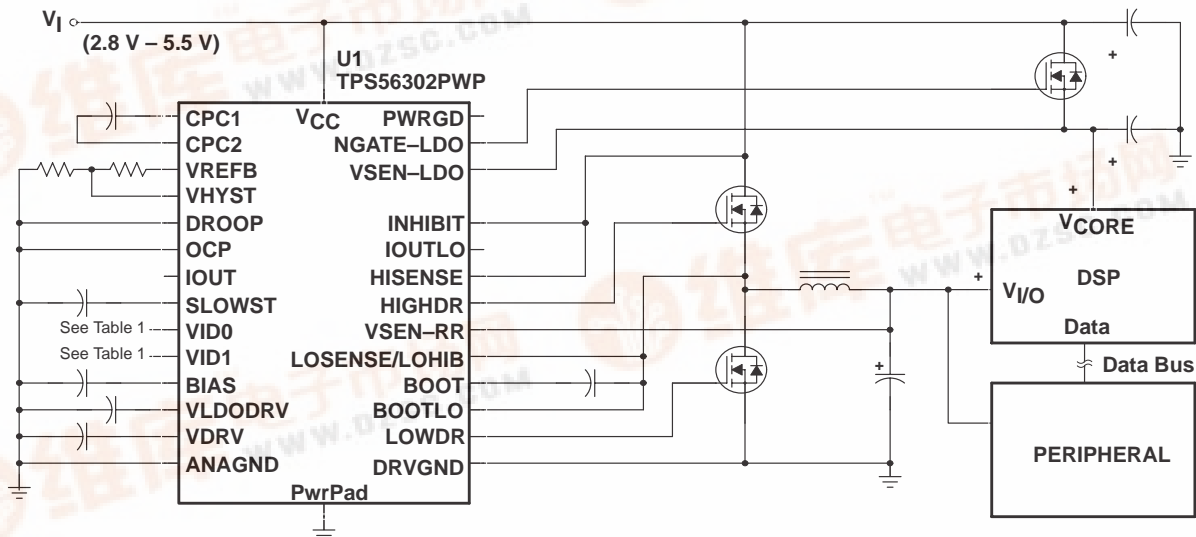

Please be aware that an important notice concerning availability, standard warranty, and use in critical applications of Texas Instruments semiconductor products and disclaimers thereto appears at the end of this data sheet.

PowerPAD is a trademark of Texas Instruments.

PRODUCTION DATA information is current as of publication date. Products conform to specifications per the terms of Texas Instruments standard warranty. Production processing does not necessarily include testing of all parameters.

# TPS56302

## DUAL-OUTPUT LOW-INPUT-VOLTAGE DSP POWER SUPPLY CONTROLLER WITH SEQUENCING

SLVS289 – MARCH 2000

### description (continued)

To promote better system reliability during power up, voltage sequencing and protection are controlled such that the core and I/O power up together with the same slow-start voltage. At power down, the LDO and ripple regulator are discharged towards ground for added protection. The TPS56302 also includes inhibit, slow-start, and under-voltage lockout features to aide in controlling power sequencing. A tri-level voltage identification definition (VID) sets both regulated voltages to any of 9 preset voltage pairs from 1.3 V to 3.3 V. Other voltages are possible by implementing an external voltage divider. Strong MOSFET drivers, with a typical peak current rating of 2-A sink and source are included on chip, which allows paralleling MOSFETs to be driven and allowing higher current to be controlled. The high-side driver features a floating bootstrap driver with an internal bootstrap synchronous rectifier. Many protection features are incorporated within the device to ensure better system integrity. An open-drain output power good status circuit monitors both output voltages, and is pulled low if either output falls below the threshold. An over current shutdown circuit protects the high-side power MOSFET against short-to-ground faults, while over voltage protection turns off the output drivers and LDO controller if either output exceeds its threshold. Under voltage protection turns off the high-side and low-side MOSFET drivers and the LDO controller if either output is 25% below  $V_{REF}$ . Lossless current-sensing is implemented by detecting the drain-source voltage drop across the high-side power MOSFET while it is conducting. The TPS56302 is fully compliant with TI DSP power requirements.

#### AVAILABLE OPTIONS

T <sub>J</sub>	PACKAGES	EVALUATION MODULE
	TSSOP† (PWP)	
-40°C to 125°C	TPS56302PWP	TPS56302EVM-163 (SLVP163)

† The PWP package is also available taped and reel. To order, add an R to the end of the part number (e.g., TPS56302PWPR).

Table 1. Voltage Identification Code†#

VID TERMINALS‡		56302		56300	
VID1	VID0	V <sub>REF-LDO</sub> <sup>#</sup> (VDC)	V <sub>REF-RR</sub> <sup>#</sup> (VDC)	V <sub>REF-RR</sub> <sup>#</sup> (VDC)	V <sub>REF-LDO</sub> <sup>#</sup> (VDC)
0	0	1.30	1.50	1.30	1.50
0	1	1.50	1.80	1.50	1.80
0	2	1.30	1.80	1.30	1.80
1	0	1.80	3.30	1.80	3.30
1	1	1.30	1.30	1.30	1.30
1	2	2.50	3.30	2.50	3.30
2	0	1.30	2.50	1.30	2.50
2	1	1.50	3.30	1.50	3.30
2	2	1.80	2.50	1.80	2.50

‡ 0 = ground (GND), 1 = floating ( $V_{BIAS}/2$ ), 2 = ( $V_{BIAS}$ )

§ RR = Ripple Regulator, LDO = Low Drop-Out Regulator

¶  $V_{BIAS}/2$  is internal, leave the VID pin floating. Adding an external 0.1- $\mu$ F capacitor to ANAGND may be used to avoid erroneous level.

# External resistors may be used as a voltage divider (from  $V_{OUT}$  to  $V_{SEN-xx}$  to ground) to program output voltages to other values.

# TPS56302 DUAL-OUTPUT LOW-INPUT-VOLTAGE DSP POWER SUPPLY CONTROLLER WITH SEQUENCING

SLVS289 – MARCH 2000

functional block diagram

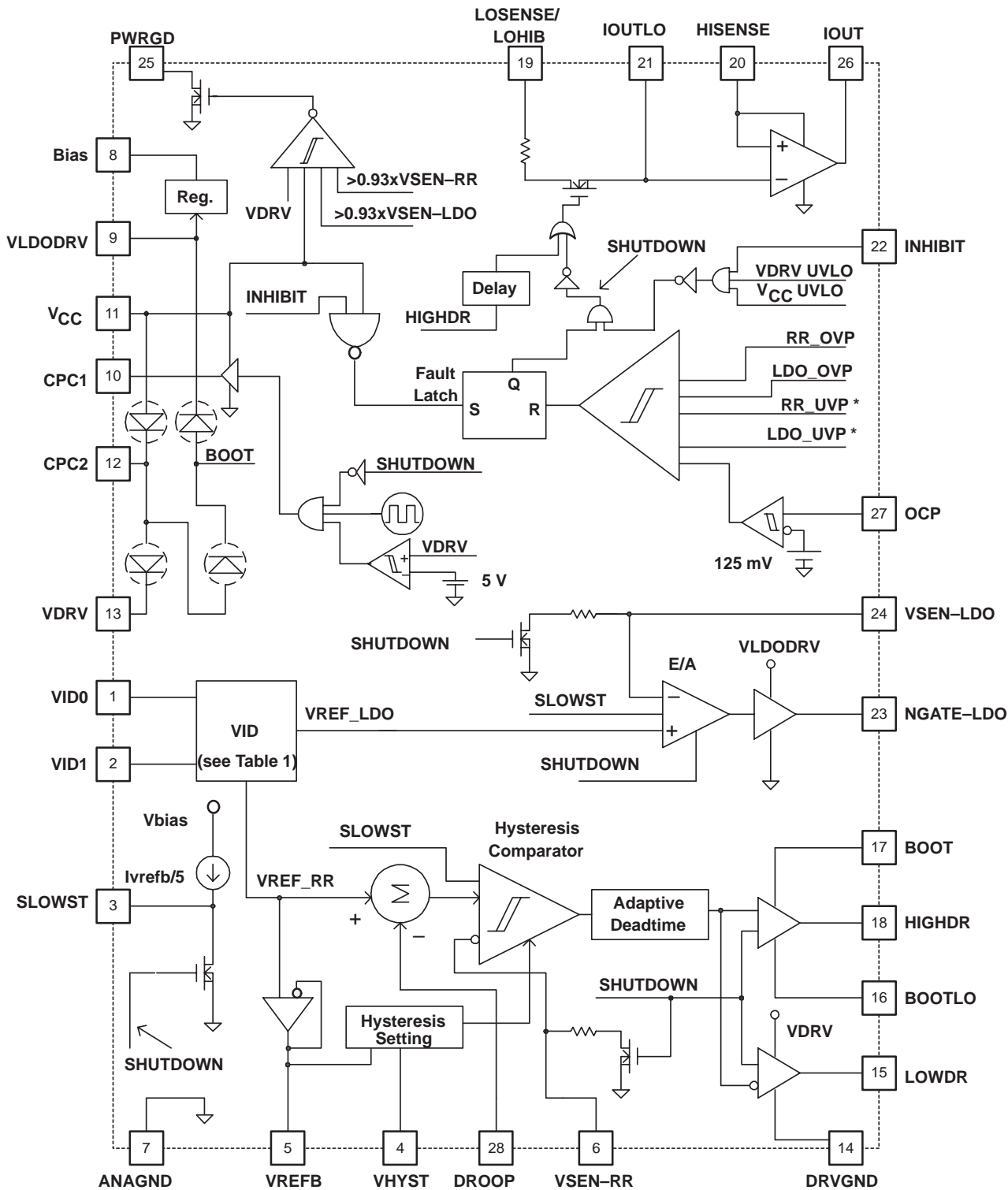

RR-Ripple Regulator

Synchronous FET

\* UVP is disabled during slowstart

**TPS56302**  
**DUAL-OUTPUT LOW-INPUT-VOLTAGE**  
**DSP POWER SUPPLY CONTROLLER WITH SEQUENCING**  
 SLVS289 – MARCH 2000

**Terminal Functions**

TERMINAL NAME	NO.	DESCRIPTION
VID0	1	Voltage Identification input 0. The VID pins are tri-level programming pins that set the output voltages for both converters. The code pattern for setting the output voltage is located in table 1. The VID pins are internally pulled to $V_{BIAS}/2$ , allowing floating voltage set to logic 1 (see Table 1).
VID1	2	Voltage Identification input 1 (see VID0 pin description and Table 1).
SLOWST	3	Slow-start (soft start). A capacitor from pin 3 to GND sets the slow-start time for $V_{OUT-RR}$ and $V_{OUT-LDO}$ . Both supplies will ramp-up together while tracking the slow-start voltage.
VHYST	4	Hysteresis set pin. The hysteresis equals $2 \times (V_{REFB} - VHYST)$ .
VREFB	5	Buffered ripple regulator reference voltage from VID network.
VSEN-RR	6	Ripple regulator voltage sense input. This pin is connected to the ripple regulator output. It is used to sense the ripple regulator voltage for regulation, OVP, UVP, and power good functions. It is recommended that an RC low pass filter be connected at this pin to filter high frequency noise.
ANAGND	7	Analog ground
BIAS	8	Analog BIAS pin. Recommended that a 1- $\mu$ F capacitor be connected to ANAGND.
VLDODRV	9	Output of charge pump generated through bootstrap diode. Approximately equal to $V_{DRV} + V_{IN} - 300$ mV. Used as supply for LDO driver and bias regulator. Recommended that a 1- $\mu$ F capacitor be connected to DRVGND.
CPC1	10	Connect one end of charge pump capacitor. Recommended that a 1- $\mu$ F capacitor be connected from CPC1 to CPC2.
$V_{CC}$	11	3.3 V or 5 V supply (2.8 V – 5.5 V). It is recommended that a low ESR capacitor be connected directly from $V_{CC}$ to DRVGND (bulk capacitors supplied at power stage input).
CPC2	12	Other end of charge pump capacitor from CPC1.
VDRV	13	Regulated output of internal charge pump. Supplies DRIVE charge for the low-side MOSFET driver (5 V). Recommended that a 10- $\mu$ F capacitor be connected to DRVGND.
DRVGND	14	Drive ground. Ground for FET drivers. Connect to source of low-side FET.
LOWDR	15	Low drive. Output drive to synchronous rectifier low-side FET.
BOOTLO	16	Bootstrap low. This pin connects to the junction of the high-side and low-side FETs.
BOOT	17	Bootstrap pin. Connect a 1- $\mu$ F low ESR capacitor to BOOTLO to generate floating drive for the high-side FET driver.
HIGHDR	18	High drive. Output drive to high-side power switching FETs
LOSENSE/ LOHIB	19	Low sense/low-side inhibit. This pin is connected to the junction of the high and low-side FETs and is used in current sensing and the anti-cross-conduction to eliminate shoot-through current.
HISENSE	20	High current sense. For current sensing across high-side FETs, connect to the drain of the high-side FETs.
IOUTLO	21	Current sense low output. Voltage on this pin is the voltage on the LOSENSE pin when the high-side FETs are on.
INHIBIT	22	This pin inhibits the drive signals to the MOSFET drivers. The IC is in a low-current state if INHIBIT is grounded. It is recommended that an external pullup resistor be connected to 5 V.
NGATE-LDO	23	Drives external N-channel power MOSFET to regulate LDO voltage to VREF-LDO.
VSEN-LDO	24	LDO voltage sense. This pin is connected to the LDO output. It is used to sense the LDO voltage for regulation, OVP, UVP, and power good functions.
PWRGD	25	Power good. Power good signal goes high when output voltage is above 93% of $V_{REF}$ for both ripple regulator and LDO. This is an open-drain output.
IOUT	26	Current signal output. Output voltage on this pin is proportional to the load current as measured across the high-side FETs on-resistance. The voltage on this pin equals $2 \times R_{ON} \times I_{OUT}$ , where $R_{ON}$ is the equivalent on-resistance of the high-side FETs
OCP	27	Over current protection. Current limit trip point for ripple regulator is set with a resistor divider between the IOUT pin and ANAGND. The trip point is typically 125 mV.
DROOP	28	Droop voltage. Voltage input used to set the amount of output voltage droop as a function of load current. The amount of droop compensation is set with a resistor divider between the IOUT pin and ANAGND.

TPS56302  
**DUAL-OUTPUT LOW-INPUT-VOLTAGE  
 DSP POWER SUPPLY CONTROLLER WITH SEQUENCING**  
 SLVS289 – MARCH 2000

**absolute maximum ratings over operating virtual junction temperature (unless otherwise noted)†**

Supply voltage range, $V_{CC}$ (see Note1)	–0.3 V to 6 V
Input voltage range: VDRV	–0.3 V to 7 V
BOOT to DRVGND (High-side Driver ON)	–0.3 V to 15 V
BOOT to BOOTLO	–0.3 V to 7 V
BOOT to HIGHDRV	–0.3 V to 7 V
BOOTLO to DRVGND	–0.5 V to 15 V
DRV to DRVGND	–0.3 V to 7 V
BIAS to ANAGND	–0.3 V to 7 V
INHIBIT	–0.3 V to 7 V
DROOP	–0.3 V to $V_{CC} + 0.3$ V
OCP	–0.3 V to 7 V
VID0, VID1 (tri-level terminals)	–0.3 V to $V_{BIAS} + 0.3$ V
PWRGD	–0.3 V to 6 V
LOSENSE, LOHIB	–0.5 V to 14 V
IOUTLO	–0.3 V to 14 V
HISENSE	–0.3 V to 7 V
VSEN–LDO	–0.3 V to 6 V
VSEN–RR	–0.3 V to 6 V
Voltage difference between ANAGND and DRVGND	±300 mV
Continuous total power dissipation	See Dissipation Rating Table
Operating junction temperature range, $T_J$	–40°C to 125°C
Storage temperature range, $T_{stg}$	–65°C to 150°C
Lead temperature soldering 1,6 mm (1/16 inch) from case for 10 seconds	300°C

† Stresses beyond those listed under “absolute maximum ratings” may cause permanent damage to the device. These are stress ratings only, and functional operation of the device at these or any other conditions beyond those indicated under “recommended operating conditions” is not implied. Exposure to absolute-maximum-rated conditions for extended periods may affect device reliability.

NOTE 1: Unless otherwise specified, all voltages are with respect to ANAGND.

**DISSIPATION RATING TABLE**

PWP	$T_A < 25^\circ\text{C}$	DERATING FACTOR‡	$T_A = 70^\circ\text{C}$	$T_A = 85^\circ\text{C}$
PowerPAD™ mounted	3.58 W	0.0358 W/°C	1.96 W	1.43 W
PowerPAD™ unmounted	1.78 W	0.0178 W/°C	0.98 W	0.71 W

‡ Test Board Conditions:

- 1.. Thickness: 0.062"
2. 3"× 3"
3. 2 oz. Copper traces located on the top of the board (0.071 mm thick )
4. Copper areas located on the top and bottom of the PCB for soldering
5. Power and ground planes, 1 oz. Copper (0.036 mm thick)
6. Thermal vias, 0.33 mm diameter, 1.5 mm pitch
7. Thermal isolation of power plane

For more information, refer to TI technical brief SLMA002.

**JUNCTION-CASE THERMAL RESISTANCE TABLE**

Junction-case thermal resistance	0.72 °C/W
----------------------------------	-----------

**TPS56302**  
**DUAL-OUTPUT LOW-INPUT-VOLTAGE**  
**DSP POWER SUPPLY CONTROLLER WITH SEQUENCING**

SLVS289 – MARCH 2000

**electrical characteristics  $T_J = 0^\circ$  to  $125^\circ\text{C}$ ,  $V_{CC} = 2.8\text{ V}$  to  $5.5\text{ V}$  (unless otherwise noted)**

**input**

PARAMETER	TEST CONDITIONS	MIN	TYP	MAX	UNITS
$V_{CC}$ Supply voltage range		2.8		5.5	V
$I_{CC}$ Quiescent current	INHIBIT = 0 V, $V_{CC} = 5\text{ V}$		15		mA

NOTE 2: Ensured by design, not production tested.

**reference/voltage identification**

PARAMETER	TEST CONDITIONS	MIN	TYP	MAX	UNITS
VID0–VID1 High-level input voltage (2)		$V_{BIAS} - 0.3\text{ V}$			V
VID0–VID1 Mid-level floating voltage (1)		$\frac{V_{BIAS}}{2} - 1$		$\frac{V_{BIAS}}{2} + 1$	V
VID0–VID1 Low-level input voltage (0)				0.3	V
Input pull-to-mid resistance		36.5	73	95	k $\Omega$

**cumulative reference**

PARAMETER	TEST CONDITIONS	MIN	TYP	MAX	UNITS
Cumulative accuracy ripple regulator	$V_{REF} = 1.3\text{ V}$ , $T_J = 25^\circ\text{C}$ , Hysteresis window = 30 mV,	-1.3%	0.25%	1.3%	
	$V_{REF} = 1.3\text{ V}$ , $T_J = -40^\circ\text{C}$ , Hysteresis window = 30 mV, See Note 2		-0.2%		
	$V_{REF} = \text{full range}$ , Droop = 0, Hysteresis window = 30 mV, See Note 2	-1.5%		1.5%	
Cumulative accuracy LDO	$V_{REF} = 1.3\text{ V}$ , Closed Loop, $T_J = 25^\circ\text{C}$ , $I_O = 0.1\text{ A}$ , Pass device = IRFZ24N, See Note 2	-2%		2%	
	$V_{REF} = \text{full range}$ , Pass device = IRFZ24N, $I_O = 0.1\text{ A}$ , Closed Loop, See Note 2	-2.5%		2.5%	

NOTE 2: Ensured by design, not production tested.

**buffered reference**

PARAMETER	CONDITIONS	MIN	TYP	MAX	UNITS
$V_{REFB}$ output voltage	$I_{REFB} = 50\ \mu\text{A}$ , Accuracy from $V_{REF}$ nominal	$V_{REF} - 1.5\%$	$V_{REF}$	$V_{REF} + 1.5\%$	V
	$I_{REFB} = 50\ \mu\text{A}$ , $T_J = -40^\circ\text{C}$ , Accuracy from $V_{REF}$ nominal See Note 2		$V_{REF} - 0.6\%$		
$V_{REFB}$ load regulation	$10\ \mu\text{A} < I_{REFB} < 500\ \mu\text{A}$		2		mV

NOTE 2: Ensured by design, not production tested.

**hysteretic comparator(ripreg)**

PARAMETER	TEST CONDITIONS	MIN	TYP	MAX	UNITS
Input bias current	See Note 2			500	nA
Hysteresis accuracy	$V_{VREFB} - V_{VHYST} = 15\text{ mV}$ , Hysteresis window = 30 mV	-3.5		3.5	mV
Maximum hysteresis setting	$V_{VREFB} - V_{VHYST} = 30\text{ mV}$ , See Note 2		60		mV
Propagation delay time from $V_{SENSE}$ to HIGHDR or LOWDR (excluding deadtime)	10 mV overdrive, $1.3\text{ V} \leq V_{REF} \leq 3.3\text{ V}$ , See Note 2		150	250	ns
Prefilter pole frequency	See Note 2		5		MHz

NOTE 2: Ensured by design, not production tested.

TPS56302  
**DUAL-OUTPUT LOW-INPUT-VOLTAGE  
 DSP POWER SUPPLY CONTROLLER WITH SEQUENCING**  
 SLVS289 – MARCH 2000

**electrical characteristics  $T_J = 0^\circ$  to  $125^\circ\text{C}$ ,  $V_{CC} = 2.8\text{ V}$  to  $5.5\text{ V}$  (unless otherwise noted) (continued)**

**overvoltage protection**

PARAMETER	TEST CONDITIONS	MIN	TYP	MAX	UNITS
OVP ripple regulator trip point (RR)	Upper threshold	112	115	120	% $V_{REF}$
Hysteresis (RR)	Upper threshold – lower threshold, (see Note 2)		10		mV
Comparator propagation delay time (RR)	$V_{overdrive} = 30\text{ mV}$ , See Note 2		1		$\mu\text{s}$
Deglintch time (includes comparator propagation delay time) (RR)	$V_{overdrive} = 30\text{ mV}$ , See Note 2	2.25		11	$\mu\text{s}$
OVP LDO trip point (LDO)	Upper threshold	112	115	120	% $V_{REF}$
Hysteresis (LDO)	Upper threshold – lower threshold, (see Note 2)		10		mV
Comparator propagation delay time (LDO)	$V_{overdrive} = 50\text{ mV}$ , See Note 2		1		$\mu\text{s}$
Deglintch time (includes comparator propagation delay time) (LDO)	$V_{overdrive} = 50\text{ mV}$ , See Note 2	2.25		11	$\mu\text{s}$

NOTE 2. Ensured by design, not production tested.

**undervoltage protection**

PARAMETER	CONDITIONS	MIN	TYP	MAX	UNITS
UVP ripple regulator trip point (RR)	Lower threshold	70	75	80	% $V_{REF}$
Hysteresis (RR)	Upper threshold – lower threshold, (see Note 2)		10		mV
Comparator propagation delay time (RR)	$V_{overdrive} = 50\text{ mV}$ , See Note 2		1		$\mu\text{s}$
Deglintch time (includes comparator propagation delay time) (RR)	$V_{overdrive} = 50\text{ mV}$ , See Note 2	0.1		1	ms
UVP LDO trip point (LDO)	Lower threshold	70	75	80	% $V_{REF}$
Hysteresis (LDO)	Upper threshold – lower threshold, (see Note 2)		10		mV
Comparator propagation delay time (LDO)	$V_{overdrive} = 50\text{ mV}$ , See Note 2		1		$\mu\text{s}$
Deglintch time (includes comparator propagation delay time) (LDO)	$V_{overdrive} = 50\text{ mV}$ , See Note 2	0.1		1	ms

NOTE 2. Ensured by design, not production tested.

**inhibit comparator**

PARAMETER	CONDITIONS	MIN	TYP	MAX	UNITS
Start threshold			2.1	2.35	V
	$T_J = -40^\circ\text{C}$ , See Note 2		2.1		
Stop threshold		1.79			V

NOTE 2. Ensured by design, not production tested.

**VDRV UVLO**

PARAMETER	CONDITIONS	MIN	TYP	MAX	UNITS
Start threshold	See Note 2			4.9	V
Hysteresis	See Note 2	0.3	0.35		V
Stop threshold	See Note 2	4.4			V

NOTE 2. Ensured by design, not production tested.

**TPS56302**  
**DUAL-OUTPUT LOW-INPUT-VOLTAGE**  
**DSP POWER SUPPLY CONTROLLER WITH SEQUENCING**  
 SLVS289 – MARCH 2000

**electrical characteristics  $T_J = 0^\circ$  to  $125^\circ\text{C}$ ,  $V_{CC} = 2.8\text{ V}$  to  $5.5\text{ V}$  (unless otherwise noted) (continued)**

**slow-start**

PARAMETER	CONDITIONS	MIN	TYP	MAX	UNITS
Charge current	$V_{(S/S)} = 0.5\text{ V}$ , Resistance from VREFB pin to ANAGND = $20\text{ k}\Omega$ $V_{REFB} = 1.3\text{ V}$ , $I_{chg} = (I_{VREFB}/5)$	10.4	13	15.6	$\mu\text{A}$
Discharge current	$V_{(S/S)} = 1.3\text{ V}$	3			mA
Comparator input offset voltage				10	mV
Comparator input bias current	See Note 2		10	100	nA
Hysteresis accuracy		-7.5		7.5	mV
Comparator propagation delay	Overdrive = $10\text{ mV}$ , See Note 2		560	1000	ns

NOTE 2. Ensured by design, not production tested.

**$V_{CC}$  UVLO**

PARAMETER	CONDITIONS	MIN	TYP	MAX	UNITS
Start threshold	(see Note 2)		2.72	2.80	V
	$T_J = -40^\circ\text{C}$ , See Note 2		2.71		
Stop threshold	(see Note 2)	2.48			V

NOTE 2. Ensured by design, not production tested.

**power good**

PARAMETER	CONDITIONS	MIN	TYP	MAX	UNITS
Undervoltage trip point ripple regulator (VSENSE-RR)	$V_{IN}$ and VDRV above UVLO thresholds	90	93	95	%VREF
	$T_J = -40^\circ\text{C}$ , See Note 2		93		
Undervoltage trip point LDO (VSENSE-LDO)	$V_{IN}$ and VDRV above UVLO thresholds	90	93	95	%VREF
	$T_J = -40^\circ\text{C}$ , See Note 2		93		
Output saturation voltage	$I_O = 5\text{ mA}$		0.5	0.75	V
Leakage current	$V_{PGD} = 4.5\text{ V}$		1		$\mu\text{A}$
Hysteresis	$V_{REF} = 1.3\text{ V}, 1.5\text{ V}, \text{ or } 1.8\text{ V}$		50	75	mV
	$V_{REF} = 2.5\text{ V}, \text{ or } 3.3\text{ V}$		100	125	mV
Comparator high-low transition time (propagation delay only)	See Note 2		1		$\mu\text{s}$
Comparator low-high transition time (propagation delay + deglitch)	See Note 2	0.2	1	2	ms

NOTE 2. Ensured by design, not production tested.

**droop compensation**

PARAMETER	CONDITIONS	MIN	TYP	MAX	UNITS
Initial accuracy	$V_{DROOP} = 50\text{ mV}$	46		54	mV

**overcurrent protection (RR)**

PARAMETER	CONDITIONS	MIN	TYP	MAX	UNITS
OCP trip point		118	130	142	mV
Input bias current				300	nA
Comparator propagation delay time	$V_{overdrive} = 30\text{ mV}$ , See Note 2		1		$\mu\text{s}$
Deglitch time (includes comparator propagation delay time)	$V_{overdrive} = 30\text{ mV}$ , See Note 2	2.25		11	$\mu\text{s}$

NOTE 2. Ensured by design, not production tested.



TPS56302  
**DUAL-OUTPUT LOW-INPUT-VOLTAGE  
 DSP POWER SUPPLY CONTROLLER WITH SEQUENCING**  
 SLVS289 – MARCH 2000

**electrical characteristics  $T_J = 0^\circ$  to  $125^\circ\text{C}$ ,  $V_{CC} = 2.8\text{ V}$  to  $5.5\text{ V}$  (unless otherwise noted) (continued)**

**high-side VDS sensing**

PARAMETER	CONDITIONS	MIN	TYP	MAX	UNITS
Gain			2		V/V
Initial accuracy	$V_{HISENSE} = 3.3\text{ V}$ , $V_{IOUTLO} = 3.2\text{ V}$ , Differential input to Vds sensing amp = 100 mV	194		208	mV
Common-mode rejection ratio	$V_{HISENSE} = 2.8\text{ V}$ to $5.5\text{ V}$ , $V_{HISENSE} - V_{IOUTLO} = 100\text{ mV}$	69	75		dB
Sink current (IOUTLO)	$2.8\text{ V} < V_{IOUTLO} < 5.5\text{ V}$			250	nA
Source current (IOUT)	$V_{IOUT} = 0.5\text{ V}$ , $V_{IOUTLO} = 2.8\text{ V}$ $V_{HISENSE} = 3.3\text{ V}$ ,	500			$\mu\text{A}$
Sink current (IOUT)	$V_{IOUT} = 0.05\text{ V}$ , $V_{IOUTLO} = 3.3\text{ V}$ $V_{HISENSE} = 3.35\text{ V}$ ,	50			$\mu\text{A}$
Output voltage swing	$V_{HISENSE} = 5.5\text{ V}$ , $R_{IOUT} = 10\text{ k}\Omega$	0		1.75	V
	$V_{HISENSE} = 4.5\text{ V}$ , $R_{IOUT} = 10\text{ k}\Omega$	0		1.5	
	$V_{HISENSE} = 3\text{ V}$ , $R_{IOUT} = 10\text{ k}\Omega$	0		0.75	
LOSENSE high-level input voltage	$V_{HISENSE} = 2.8\text{ V}$ , See Note 2	1.77			V
LOSENSE low-level input voltage	$V_{HISENSE} = 2.8\text{ V}$ , See Note 2			1.49	V
LOSENSE high-level input voltage	$V_{HISENSE} = 4.5\text{ V}$ , See Note 2	2.85			V
LOSENSE low-level input voltage	$V_{HISENSE} = 4.5\text{ V}$ , See Note 2			2.4	V
LOSENSE high-level input voltage	$V_{HISENSE} = 5.5\text{ V}$ , See Note 2	3.80			V
LOSENSE low-level input voltage	$V_{HISENSE} = 5.5\text{ V}$ , See Note 2			3.2	V
Sample/hold resistance	$V_{HISENSE} = 6\text{ V}$ , See Note 2	70		90	$\Omega$
	$V_{HISENSE} = 4.5\text{ V}$ , See Note 2	80		100	
	$V_{HISENSE} = 3.6\text{ V}$ , See Note 2	90		120	
	$V_{HISENSE} = 2.8\text{ V}$ , See Note 2	120		180	
Response time (measured from 90% of $V_{IOUTLO}$ to 90% of $V_{IOUT}$ )	$V_{HISENSE} = 2.55\text{ V}$ , $V_{IOUTLO}$ pulsed from 2.55 V to 2.45 V, 100 ns rise and fall times, See Note 2			4	$\mu\text{s}$
	$V_{HISENSE} = 2.8\text{ V}$ , $V_{IOUTLO}$ pulsed from 2.8 V to 2.7 V, 100 ns rise and fall times, See Note 2			3.5	
	$V_{HISENSE} = 4.5\text{ V}$ , $V_{IOUTLO}$ pulsed from 4.5 V to 4.4 V, 100 ns rise and fall times, See Note 2			3	
	$V_{HISENSE} = 5.5\text{ V}$ , $V_{IOUTLO}$ pulsed from 5.5 V to 5.9 V, 100 ns rise and fall times, See Note 2			3	
Short circuit protection rising edge delay	LOSENSE grounded, See Note 2	300		500	ns
Sample/hold switch turnon/turnoff delay	$2.8\text{ V} < V_{HISENSE} < 5.5\text{ V}$ , $V_{LOSENSE} = V_{HISENSE}$ , See Note 2	30		100	ns

NOTE 2. Ensured by design, not production tested.

**TPS56302**  
**DUAL-OUTPUT LOW-INPUT-VOLTAGE**  
**DSP POWER SUPPLY CONTROLLER WITH SEQUENCING**  
 SLVS289 – MARCH 2000

**electrical characteristics  $T_J = 0^\circ$  to  $125^\circ\text{C}$ ,  $V_{CC} = 2.8\text{ V}$  to  $5.5\text{ V}$  (unless otherwise noted) (continued)**

**thermal shutdown**

PARAMETER	CONDITIONS	MIN	TYP	MAX	UNITS
Over temperature trip point	See Note 2		145		$^\circ\text{C}$
Hysteresis	See Note 2		10		$^\circ\text{C}$

NOTE 2. Ensured by design, not production tested.

**synch charge pump regulator**

PARAMETER	CONDITIONS	MIN	TYP	MAX	UNITS
Internal oscillator frequency	$2.8\text{ V} < V_{IN} < 5.5\text{ V}$ , $V_{DRV}=5\text{ V}$ , $I_{DRV} = 50\text{ mA}$ , See Note 2	200	300	400	kHz
Internal oscillator turnon threshold	$V_{CC}$ above UVLO threshold, See Note 2	5.05	5.2		V
Internal oscillator turnon hysteresis	$V_{CC}$ above UVLO threshold, See Note 2			20	mV

NOTE 2. Ensured by design, not production tested.

**hysteretic comparator (charge pump)**

PARAMETER	CONDITIONS	MIN	TYP	MAX	UNITS
Threshold	$V_{IN}$ above UVLO threshold, See Note 2	5.05	5.2		V
Hysteresis	$V_{IN}$ above UVLO threshold, See Note 2			20	mV

NOTE 2. Ensured by design, not production tested.

**deadtime circuit**

PARAMETER	CONDITIONS	MIN	TYP	MAX	UNITS
LOSENSE/LOHIB high level input voltage	$V_{HISENSE}=2.55\text{ V} - 5.5\text{ V}$ , See Note 2	2.4			V
LOSENSE/LOHIB low level input voltage	$V_{HISENSE}=2.55\text{ V} - 5.5\text{ V}$ , See Note 2			1.33	V
LOWDR high level input voltage	$V_{HISENSE}=2.55\text{ V} - 5.5\text{ V}$ , See Note 2	3			V
LOWDR low level input voltage	$V_{HISENSE}=2.55\text{ V} - 5.5\text{ V}$ , See Note 2			1.7	V
Driver nonoverlap time	$C_{LOWDR} = 9\text{ nF}$ , $V_{DRV}=5\text{ V}$ , 10% threshold on LOWDR,	40		170	ns

NOTE 2. Ensured by design, not production tested.

TPS56302  
**DUAL-OUTPUT LOW-INPUT-VOLTAGE  
 DSP POWER SUPPLY CONTROLLER WITH SEQUENCING**  
 SLVS289 – MARCH 2000

electrical characteristics  $T_J = 0^\circ$  to  $125^\circ\text{C}$ ,  $V_{CC} = 2.8\text{ V}$  to  $5.5\text{ V}$  (unless otherwise noted) (continued)

output drivers (see Note 5)

PARAMETER	CONDITIONS	MIN	TYP	MAX	UNITS
Peak output current	Duty cycle < 2%, $V_{BOOT} - V_{BOOTLO} = 4.5\text{ V}$ , $V_{HIGHDR} = 4\text{ V}$ (sink), $t_{pw} < 100\text{ }\mu\text{s}$ , See Note 2 and Figure 15	0.7	2		A
	Duty cycle < 2%, $V_{BOOT} - V_{BOOTLO} = 4.5\text{ V}$ , $V_{HIGHDR} = 0.5\text{ V}$ (source), $t_{pw} < 100\text{ }\mu\text{s}$ , See Note 2 and Figure 15	1.2	2		
	Duty cycle < 2%, $V_{DRV} = 4.5\text{ V}$ , See Note 2 and Figure 15 $t_{pw} < 100\text{ }\mu\text{s}$ , $V_{LOWDR} = 4\text{ V}$ (sink),	1.3	2		
	Duty cycle < 2%, $V_{DRV} = 4.5\text{ V}$ , See Note 2 and Figure 15 $t_{pw} < 100\text{ }\mu\text{s}$ , $V_{LOWDR} = 0.5\text{ V}$ (source),	1.4	2		
Output resistance	$V_{BOOT} - V_{BOOTLO} = 4.5\text{ V}$ , $V_{HIGHDR} = 0.5\text{ V}$ , See Note 2			5	$\Omega$
	$V_{BOOT} - V_{BOOTLO} = 4.5\text{ V}$ , $V_{HIGHDR} = 4\text{ V}$ , See Note 2			45	
	$V_{DRV} = 4.5\text{ V}$ , $V_{LOWDR} = 0.5\text{ V}$ , See Note 2			9	
	$V_{DRV} = 4.5\text{ V}$ , $V_{LOWDR} = 4\text{ V}$ , See Note 2			45	
HIGHDR rise/fall time	$C_L = 3.3\text{ nF}$ , $V_{BOOT} = 4.5\text{ V}$ , $V_{BOOTLO} = \text{grounded}$ , See Note 2			60	ns
LOWDR rise/fall time	$C_L = 3.3\text{ nF}$ , $V_{DRV} = 4.5\text{ V}$ , See Note 2			40	ns
High-side driver quiescent current	INHIBIT grounded, BOOTLO grounded $V_{IN} < UVLO$ , $V_{BOOT} = 6\text{ V}$ ,			10	$\mu\text{A}$
	INHIBIT connected to +5 V, $f_{(swx)} = 200\text{ kHz}$ , BOOTLO = 0, See Note 2 $V_{IN} > UVLO$ $V_{BOOT} = 5.5\text{ V}$ , $C_{HIGHDR} = 50\text{ pF}$ ,		2		mA

NOTES: 2. Ensured by design, not production tested.

5. The pullup/pulldown circuits of the drivers are bipolar and MOSFET transistors in parallel. The peak output current rating is the combined current from the bipolar and MOSFET transistors. The output resistance is the  $R_{ds(on)}$  of the MOSFET transistor when the voltage on the driver output is less than the saturation voltage of the bipolar transistor.

**LDO N-channel output driver**

PARAMETER	CONDITIONS	MIN	TYP	MAX	UNITS
Peak output current	$V_{LDODRV} = 7.5\text{ V}$ , $V_{IOSENSE} = 0.9 \times V_{LDOREF}$ , $V_{N-DRV} = 3\text{ V}$ (source), See Note 2	100			$\mu\text{A}$
	$V_{LDODRV} = 7.5\text{ V}$ , $V_{IOSENSE} = 1.1 \times V_{LDOREF}$ , $V_{N-DRV} = 0\text{ V}$ (sink), See Note 2	1.5			mA
Open loop voltage gain ( $V_{NGATE-LDO} / V_{SENSE-LDO}$ )	$7.5\text{ V} \geq V_{NGATE-LDO} \geq 0.5\text{ V}$ , See Note 2 $V_{IN} = 5.5\text{ V}$ ,	3000 (70)			V/V (dB)
Power supply ripple rejection	$f = 1\text{ kHz}$ , $5.5\text{ V} \geq V_{IN} \geq 2.55\text{ V}$ , See Note 2 $C_O = 10\text{ }\mu\text{F}$ , $T_J = 125^\circ\text{C}$ ,	60			dB

NOTE 2. Ensured by design, not production tested.

**TPS56302**  
**DUAL-OUTPUT LOW-INPUT-VOLTAGE**  
**DSP POWER SUPPLY CONTROLLER WITH SEQUENCING**  
 SLVS289 – MARCH 2000

**electrical characteristics  $T_J = 0^\circ$  to  $125^\circ\text{C}$ ,  $V_{CC} = 2.8\text{ V}$  to  $5.5\text{ V}$  (unless otherwise noted) (continued)**

**$V_{\text{SENSE-RR}}$  and  $V_{\text{SENSE-LDO}}$  discharge**

PARAMETER	CONDITIONS	MIN	TYP	MAX	UNITS
$V_{\text{SENSE-RR}}$ discharge FET current saturation	$V_{\text{SENSE-RR}} = 1.5\text{ V}$ , See Note 2		5		mA
$V_{\text{SENSE-RR}}$ discharge series resistance (limits current)	INHIBIT = 0 V, $V_{\text{IN}} = 5.5\text{ V}$		1		k $\Omega$
$V_{\text{SENSE-RR}}$ discharge FET propagation delay time	See Note 2			100	ns
$V_{\text{SENSE-LDO}}$ discharge FET current saturation	$V_{\text{SENSE-LDO}} = 3.3\text{ V}$ , See Note 2		5		mA
$V_{\text{SENSE-LDO}}$ discharge series resistance (limits current)	INHIBIT = 0 V, $V_{\text{IN}} = 5.5\text{ V}$ ,		1		k $\Omega$
$V_{\text{SENSE-LDO}}$ discharge FET propagation delay time	See Note 2			100	ns

NOTE 2. Ensured by design, not production tested.

**detailed description**

**reference/voltage identification**

The reference/voltage identification definition (VID) section consists of a temperature compensated bandgap reference and a 2-pin voltage selection network. Both ripple regulator and LDO reference voltages are programmed with each VID setting. The 2 VID pins are inputs to the VID selection network and are tri-level inputs that may be set to GND, floating ( $V_{\text{BIAS}}/2$ ), or  $V_{\text{BIAS}}$ . The VID codes allow the controller to power both current and future DSP products. The output voltages may also be programmed by external resistor voltage dividers for any values not included in the VID code settings. Refer to Table 1 for the VID code settings. The output voltages of the VID network,  $V_{\text{REF-RR}}$ , is within 1.5% and  $V_{\text{REF-LDO}}$  is within 2.5% of the nominal setting over the VID range of 1.3 V to 3.3 V. The reference tolerance conditions include a junction temperature range of  $-40^\circ\text{C}$  to  $+125^\circ\text{C}$  and a  $V_{\text{CC}}$  supply voltage range of 2.8 V to 5.5 V. The  $V_{\text{REF-RR}}$  output of the reference/VID network is indirectly brought out through a buffer to the VREFB pin. The voltage on this pin will be within 1.5% of  $V_{\text{REF-RR}}$ . It is not recommended to drive loads with VREFB, other than setting the hysteresis of the hysteretic comparator, because the current drawn from VREFB sets the charging current for the slow-start capacitor. Refer to the Slow-start section of this document for additional information.

**hysteretic comparator**

The hysteretic comparator regulates the output voltage of the synchronous-buck converter. The hysteresis is set by 2 external resistors and is centered around  $V_{\text{REF}}$ . The two external resistors form a resistor divider from VREFB to ANAGND, and the divided down voltage connects to the VHYST pin. The hysteresis of the comparator will be equal to twice the voltage difference that is across the VREFB and VHYST pins. The propagation delay from the comparator inputs to the driver outputs is 250 ns maximum. The maximum hysteresis setting is 60 mV.

**low-side driver**

The low-side driver is designed to drive low  $r_{\text{DS(on)}}$  logic-level N-channel MOSFETs. The current rating of the driver is 2-A typical, source and sink. The bias to the low-side driver is internally connected to the regulated synchronous charge pump output.

**high-side driver**

The high-side driver is designed to drive low  $r_{\text{DS(on)}}$  logic-level N-channel MOSFETs. The current rating of the driver is 2 amps typical, source and sink. The high-side driver can be configured either as a floating bootstrap driver or as a ground-reference driver. When configured as a floating driver, the bias voltage to the driver is developed from the charge pump VDRV voltage. The internal synchronous bootstrap rectifier, connected between the VDRV and BOOT pins, is a synchronously-rectified MOSFET for improved drive efficiency. The maximum voltage that can be applied between the BOOT pin and ground is 14 V.

## detailed description (continued)

### deadtime control

Deadtime control prevents shoot-through current from flowing through the main power FETs during switching transitions by actively controlling the turnon time of the MOSFET drivers. The high-side driver is not allowed to turn on until the gate drive voltage to the low-side FET is below 1 V, and the low-side driver is not allowed to turn on until the voltage at the junction of the 2 FETs ( $V_{\text{phase}}$ ) is below 2 V.

### current sensing

Current sensing is achieved by sampling and holding the voltage across the high-side power FET while the high-side FET is on. The sampling network consists of an internal 60- $\Omega$  switch and an external hold capacitor. Internal logic controls the turnon and turnoff of the sample/hold switch such that the switch does not turn on until the  $V_{\text{phase}}$  voltage transitions high, and the switch turns off when the input to the high-side driver goes low. Thus sampling will occur only when the high-side FET is conducting current. The voltage on the IOUT pin equals 2 times the sensed high-side voltage.

### droop compensation

The droop compensation network reduces the load transient overshoot / undershoot on  $V_{\text{OUT}}$ , relative to  $V_{\text{REF}}$  (see the *application information* section of this document for more details).  $V_{\text{OUT}}$  is programmed to a voltage greater than  $V_{\text{REF}}$  by an external resistor divider from  $V_{\text{OUT}}$  to the  $V_{\text{SENSE}}$  pin to reduce the undershoot on  $V_{\text{OUT}}$  during a low to high load transient. The overshoot during a high to low load transient is reduced by subtracting the voltage that is on the DROOP pin from  $V_{\text{REF}}$ . The voltage on the IOUT pin is divided down with an external resistor divider, and connected to the DROOP pin.

### inhibit

INHIBIT is a TTL-compatible comparator pin that is used to enable the controller. When INHIBIT is lower than the threshold, the output drivers are low and the slow-start capacitor is discharged. When INHIBIT goes high (above 2.1 V), the short across the slow-start capacitor is released and normal converter operation begins. When another system logic supply is connected to the INHIBIT pin, this pin controls power sequencing by locking out controller operation until the system logic supply exceeds the input threshold voltage of the inhibit circuit; thus the +3.3-V supply and another system logic supply (either +5 V or +12 V) must be above UVLO thresholds before the controller is allowed to start up. Toggling the INHIBIT pin from low to high or recycling  $V_{\text{CC}}$  clears the fault latch.

### slow-start

The slow-start circuit controls the rate at which both  $V_{\text{OUT-RR}}$  and  $V_{\text{OUT-LDO}}$  power up (at the same time). A capacitor is connected between the SLOWST and ANAGND pins and is charged by an internal current source. The value of the current source is proportional to the reference voltage, so that the charging rate of  $C_{\text{SLOWST}}$  is proportional to the ripple regulator reference voltage. The slow-start charging current is determined by the following equation:

$$I_{\text{SLOWSTART}} = \frac{I_{\text{VREFB}}}{5}$$

Where  $I_{\text{VREFB}}$  is the current flowing out of the VREFB pin. It is recommended that no additional loads be connected to VREFB, other than the resistor divider for setting the hysteresis voltage. Thus these resistor values will determine the slow-start charging current. The maximum current that can be sourced by the VREFB circuit is 500  $\mu\text{A}$ . The equation for the slow-start time is:

$$T_{\text{SLOWSTART}} = 5 \times C_{\text{SLOWSTART}} \times R_{\text{VREFB}}$$

Where  $R_{\text{VREFB}}$  is the total external resistance from VREFB to ANAGND.

# TPS56302

## DUAL-OUTPUT LOW-INPUT-VOLTAGE DSP POWER SUPPLY CONTROLLER WITH SEQUENCING

SLVS289 – MARCH 2000

---

### detailed description (continued)

#### $V_{CC}$ and VDRV undervoltage lockout

The  $V_{CC}$  undervoltage lockout circuit disables the controller while the  $V_{CC}$  supply is below the 2.8-V start threshold. The VDRV undervoltage lockout circuit disables the controller while the VDRV supply is below the 4.9 V start threshold during powerup. While the controller is disabled, the output drivers will be low, the LDO drive is off, and the slow-start capacitor will be shorted. When  $V_{CC}$  and VDRV exceed the start threshold, the short across the slow-start capacitor is released and normal converter operation begins. Recycling  $V_{CC}$  or toggling the INHIBIT pin from low to high clears the fault latch.

#### power good

The power good circuit monitors for an undervoltage condition on  $V_{OUT-RR}$  and  $V_{OUT-LDO}$ . The power good (PWRGD) pin is pulled low if either  $V_{OUT-RR}$  is 7% below  $V_{REF-RR}$ , or  $V_{OUT-LDO}$  is 7% below  $V_{REF-LDO}$ . PWRGD is an open drain output. The PWRGD pin is also pulled down, if either  $V_{CC}$  or VDRV are below their UVLO thresholds.

#### overvoltage protection

The overvoltage protection circuit monitors  $V_{OUT-RR}$  and  $V_{OUT-LDO}$  for an overvoltage condition. If  $V_{OUT-RR}$  or  $V_{OUT-LDO}$  are 15% above their reference voltage, then a fault latch is set and both output drivers and LDO are turned off. The latch remains set until the  $V_{CC}$  or inhibit voltages go below their undervoltage lockout turnoff values. A 1- $\mu$ s to 5  $\mu$ s deglitch timer is included for noise immunity.

#### overcurrent protection

The overcurrent protection circuit monitors the current through the high-side FET. The overcurrent threshold is adjustable with an external resistor divider between IOUT and ANAGND pins, with the divider voltage connected to the OCP pin. If the voltage on the OCP pin exceeds 125 mV, a fault latch is then set and the output drivers are turned off. The latch remains set until the  $V_{CC}$  or inhibit voltages go below their undervoltage lockout values. A 1- $\mu$ s to 5- $\mu$ s deglitch timer is included for noise immunity. The OCP circuit is also designed to protect the high-side power FET against a short-to-ground fault on the terminal common to both power FETs.

#### undervoltage protection

The undervoltage protection circuit monitors  $V_{OUT-RR}$  and  $V_{OUT-LDO}$  for an undervoltage condition. If  $V_{OUT-RR}$  or  $V_{OUT-LDO}$  is 15% below their reference voltage, then a fault latch is set and both output drivers and LDO are turned off. The latch remains set until the  $V_{CC}$  or inhibit voltages go below their undervoltage lockout values. A 100- $\mu$ s to 1-ms deglitch timer is included for noise immunity.

#### synchronous charge pump

The regulated synchronous charge pump provides drive voltage to the low-side driver at VDRV (5 V), and to the high-side driver configured as a floating driver. The minimum drive voltage is 4.5 V, (typical is 5 V). The minimum short-circuit current is 80 mA. The bootstrap capacitor is used to provide voltage for the high-side FET, the power for VLDODRV, and the bias regulator. Instead of diodes, synchronous rectified MOSFETs are used to reduce voltage drop losses and allow a lower input voltage threshold. The charge pump oscillator operates at 300 kHz until the UVLO VDRV is set; after which it is synchronized to the converter switching frequency and is turned on and off to regulate VDRV at 5 V.

The charge pump is designed to operate at a switching frequency of 200 kHz to 400 kHz. Operation at low frequency may require larger capacitors on the CPCx and VDRV pins. Higher frequencies (> 400 kHz) may not be possible.

#### power sequence

The  $V_{OUT-LDO}$  voltage is powered up with respect to the same slow-start reference voltage as the  $V_{OUT-RR}$ . Also, at power down, the  $V_{OUT-RR}$  and  $V_{OUT-LDO}$  are discharged to ground through P-channel MOSFETs in series with 1-k $\Omega$  resistors.

**TYPICAL CHARACTERISTICS**

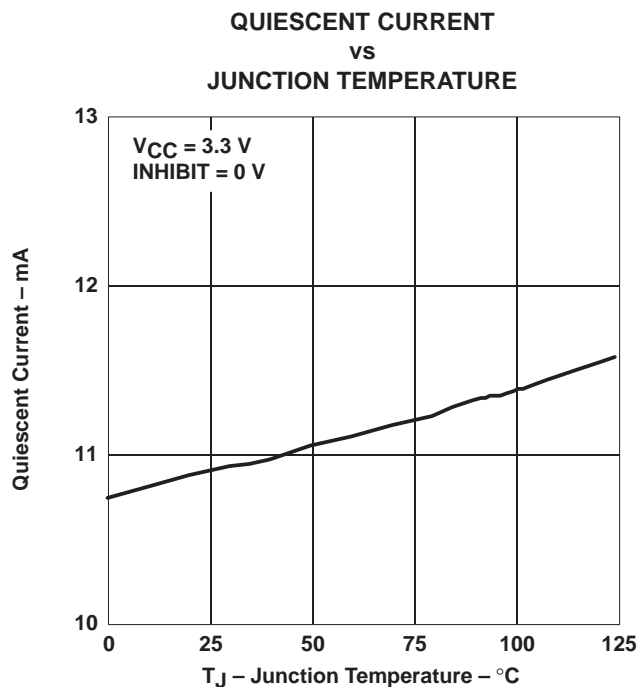

**Figure 1**

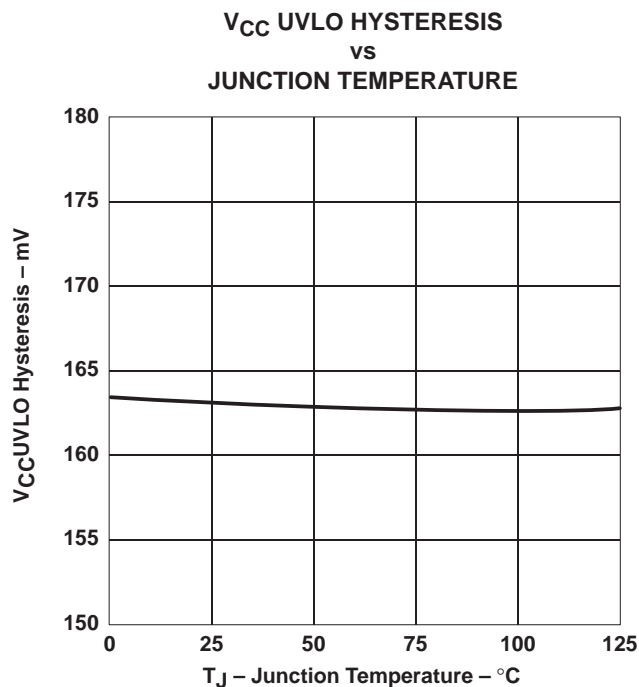

**Figure 2**

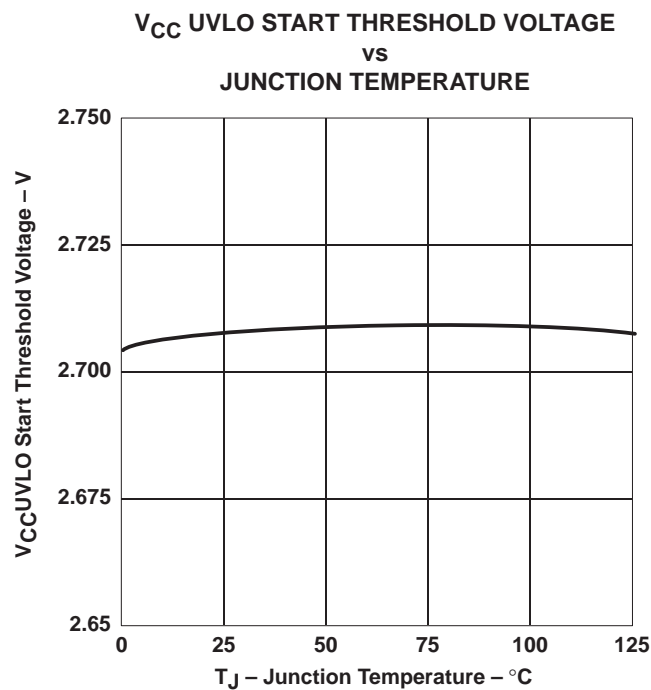

**Figure 3**

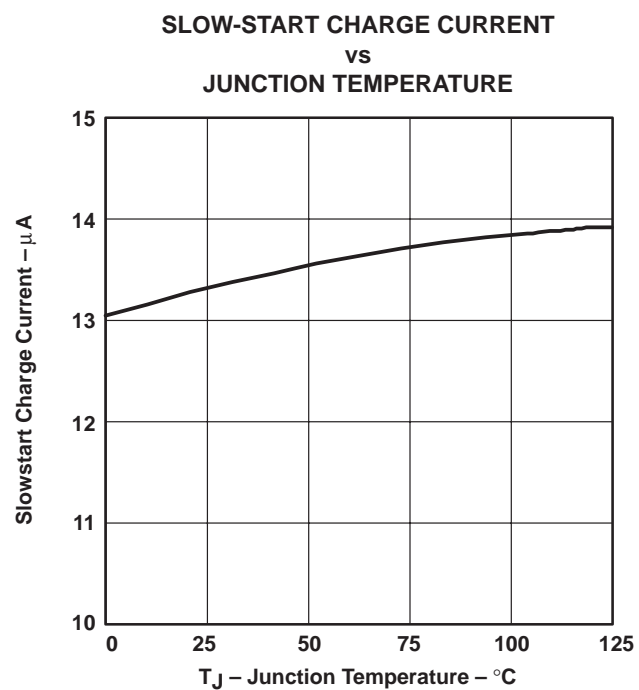

**Figure 4**

TYPICAL CHARACTERISTICS

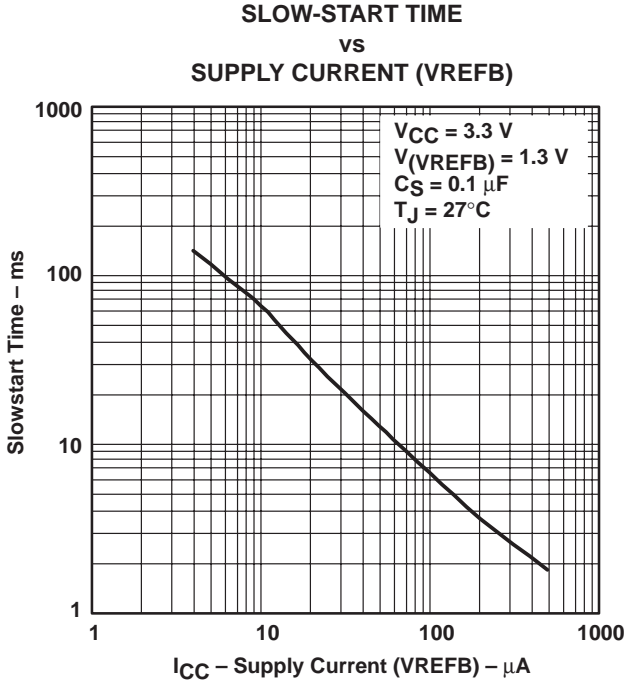

Figure 5

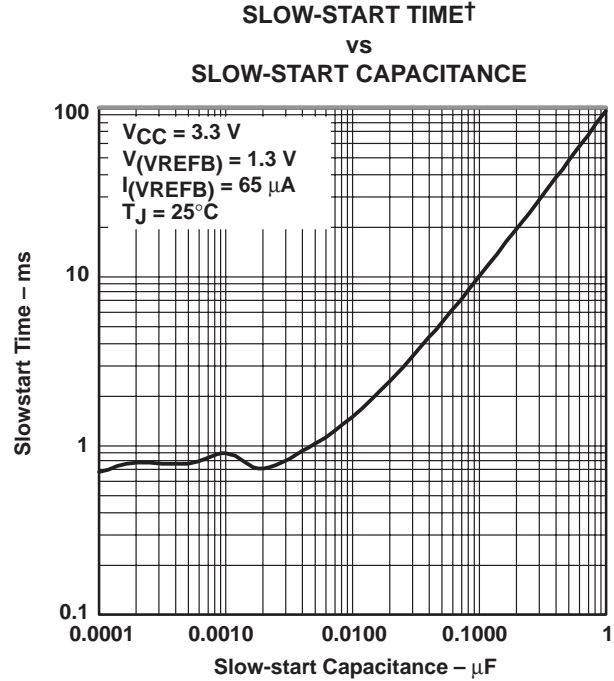

Figure 6

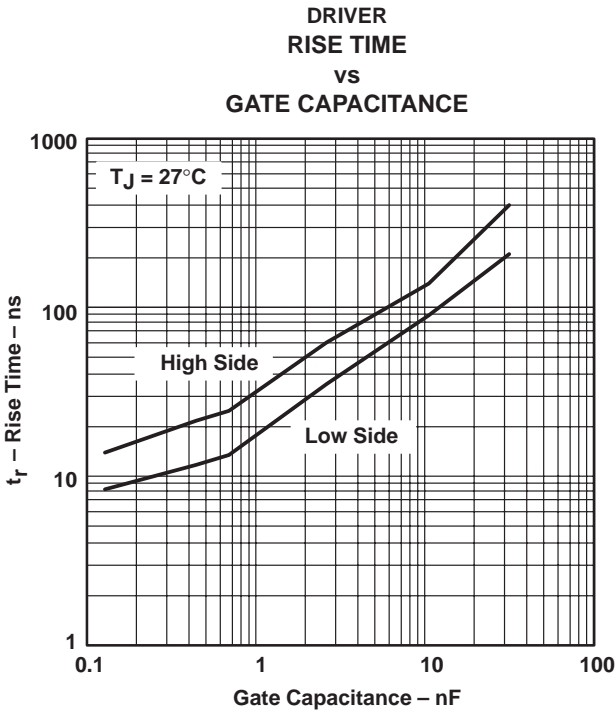

Figure 7

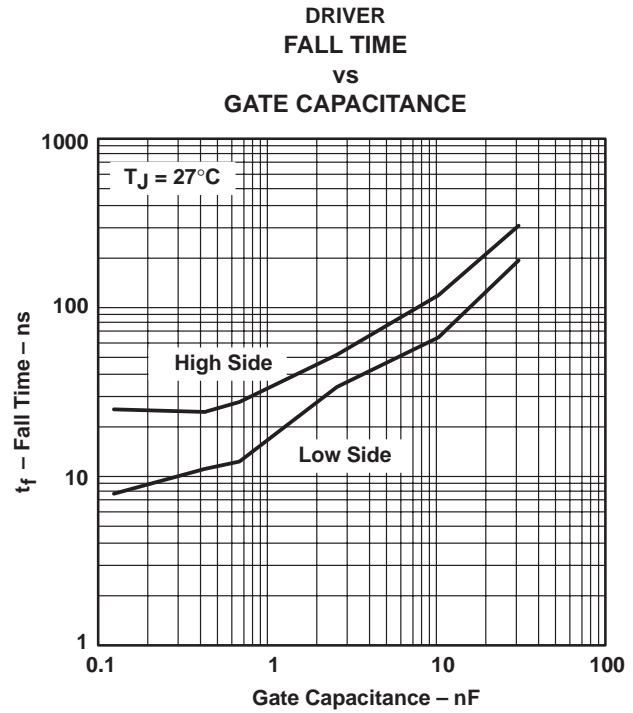
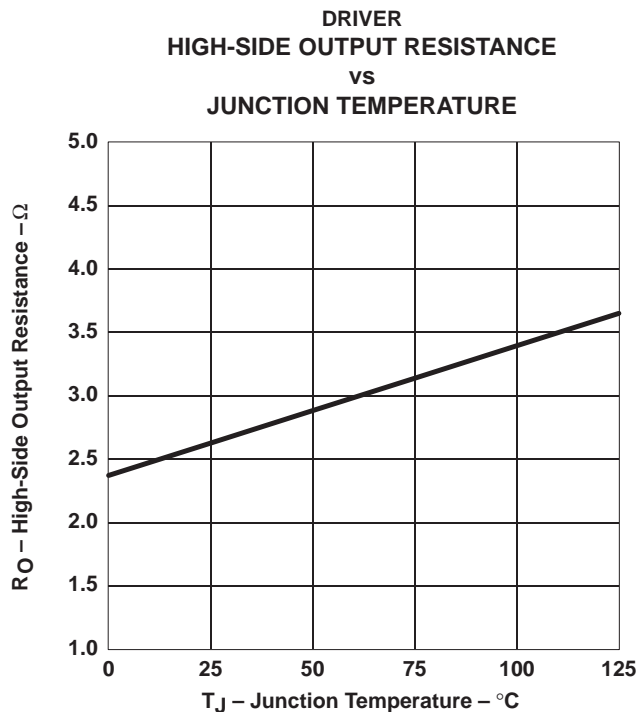

Figure 8



**TYPICAL CHARACTERISTICS**



**Figure 9**

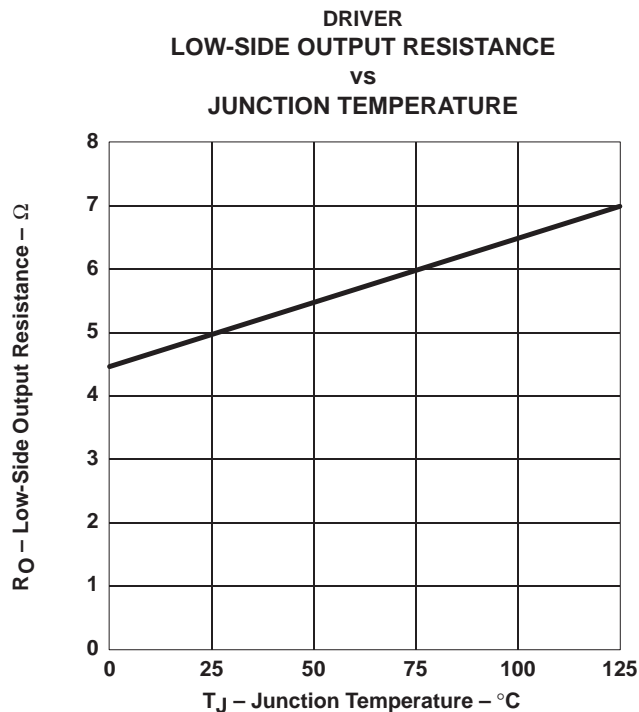

**Figure 10**

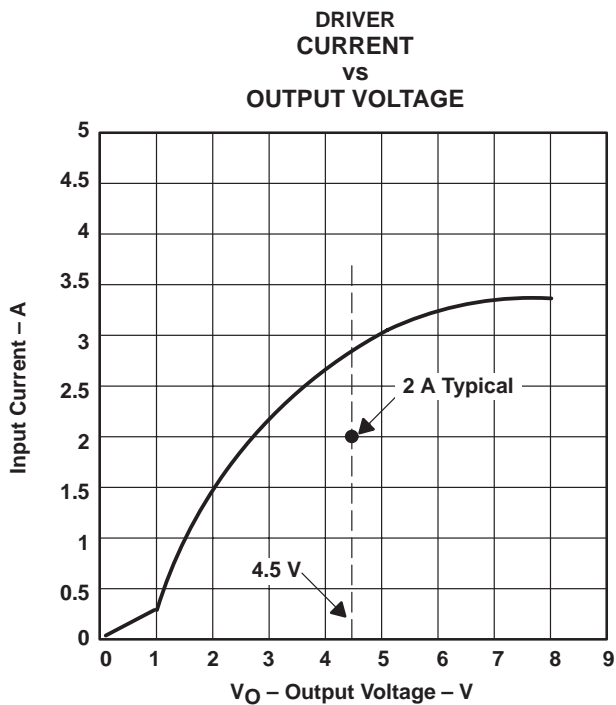

**Figure 11**

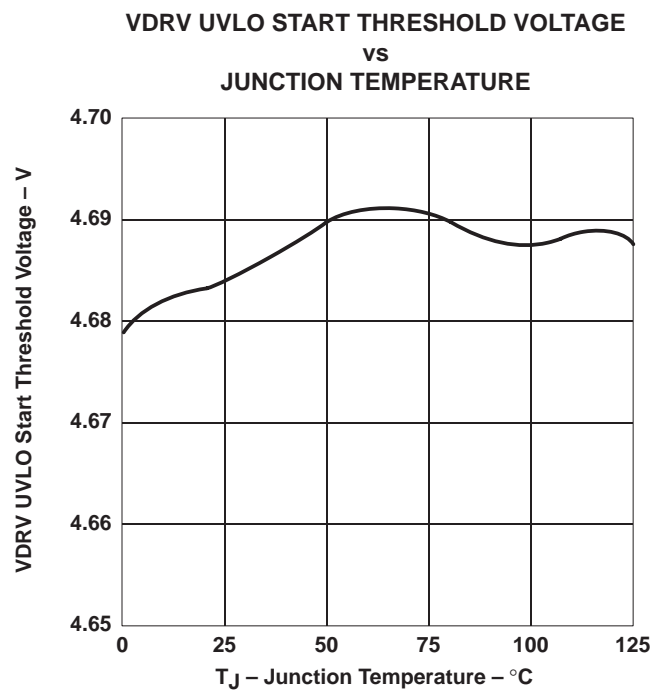

**Figure 12**

TYPICAL CHARACTERISTICS

VDRV UVLO HYSTERESIS  
 vs  
 JUNCTION TEMPERATURE

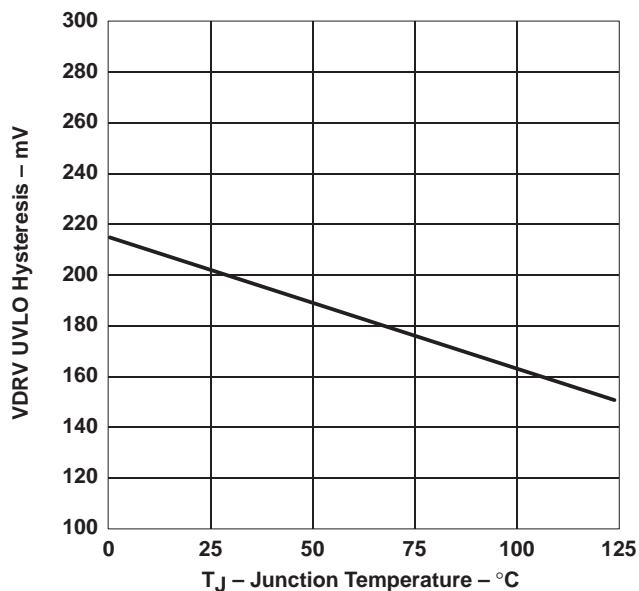

Figure 13

RIPPLE REGULATOR  
 POWER GOOD THRESHOLD  
 vs  
 JUNCTION TEMPERATURE

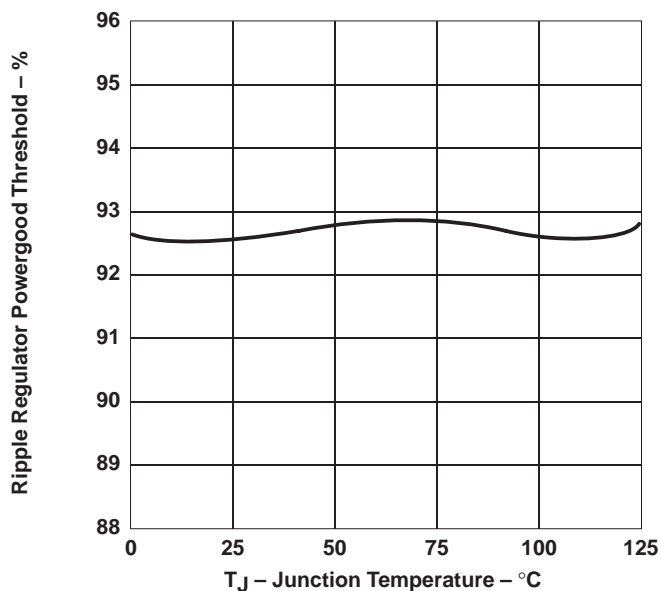

Figure 14

INHIBIT START THRESHOLD VOLTAGE  
 vs  
 JUNCTION TEMPERATURE

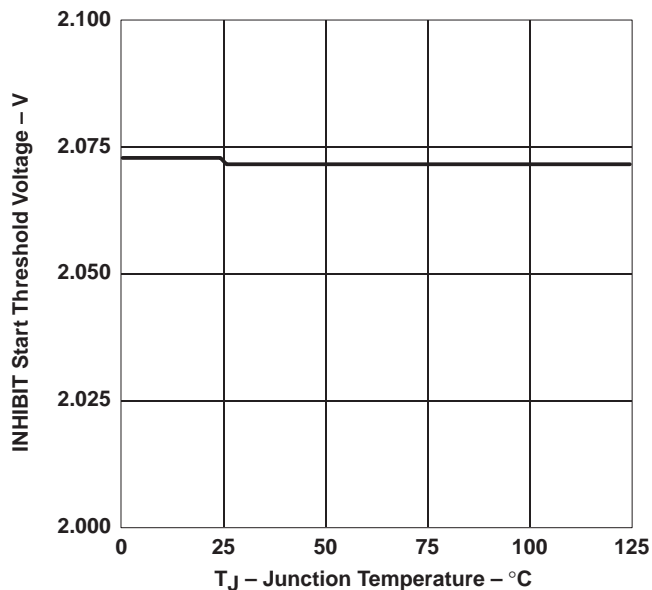

Figure 15

INHIBIT HYSTERESIS VOLTAGE  
 vs  
 JUNCTION TEMPERATURE

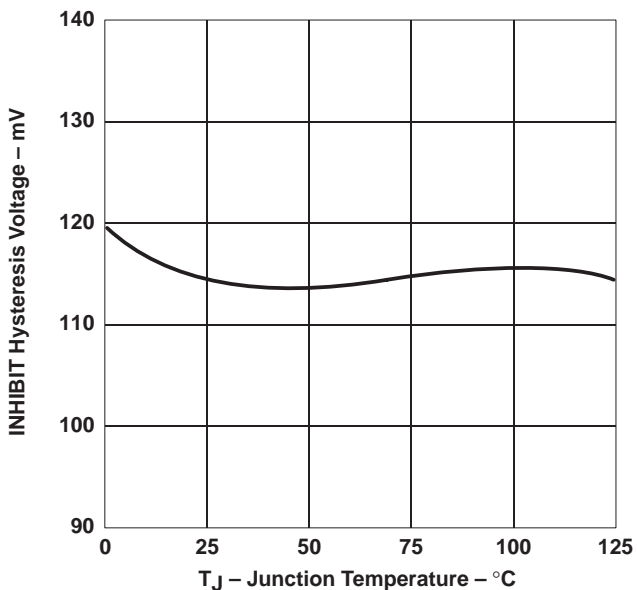

Figure 16

**TYPICAL CHARACTERISTICS**

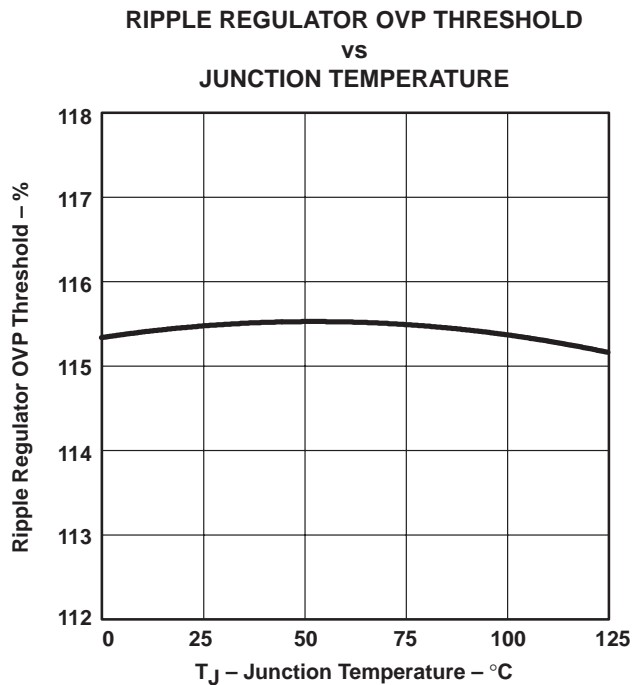

Figure 17

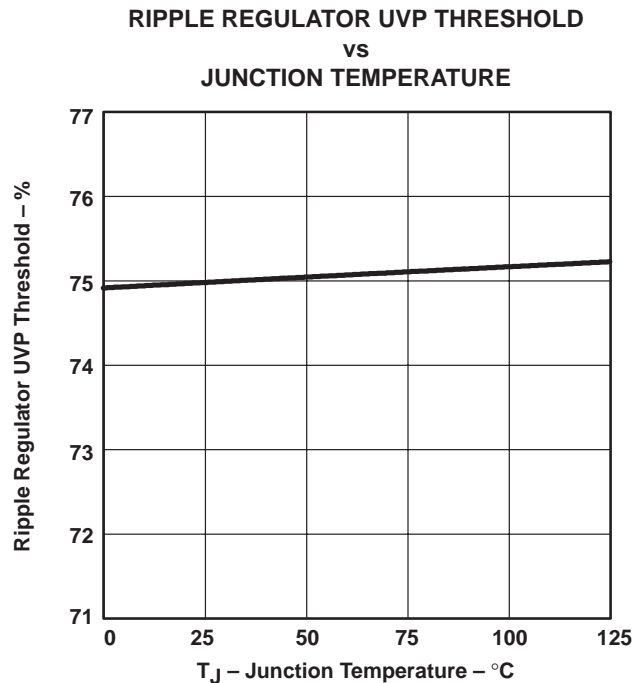

Figure 18

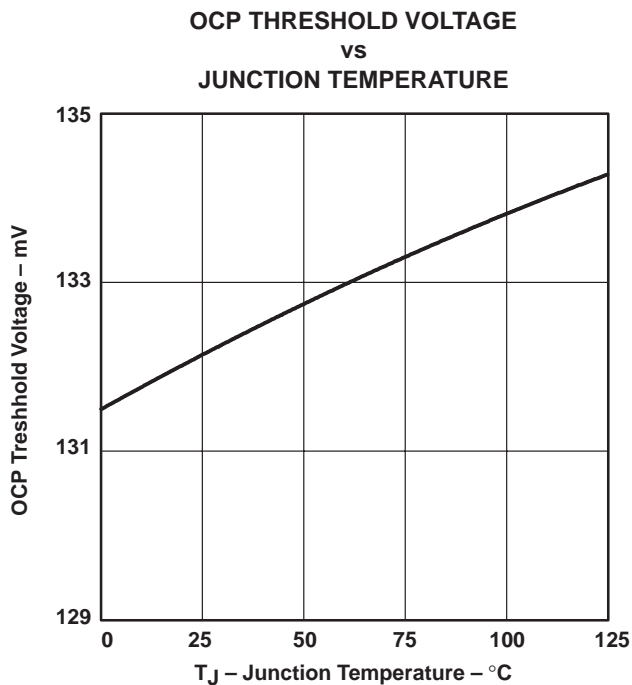

Figure 19

TYPICAL CHARACTERISTICS

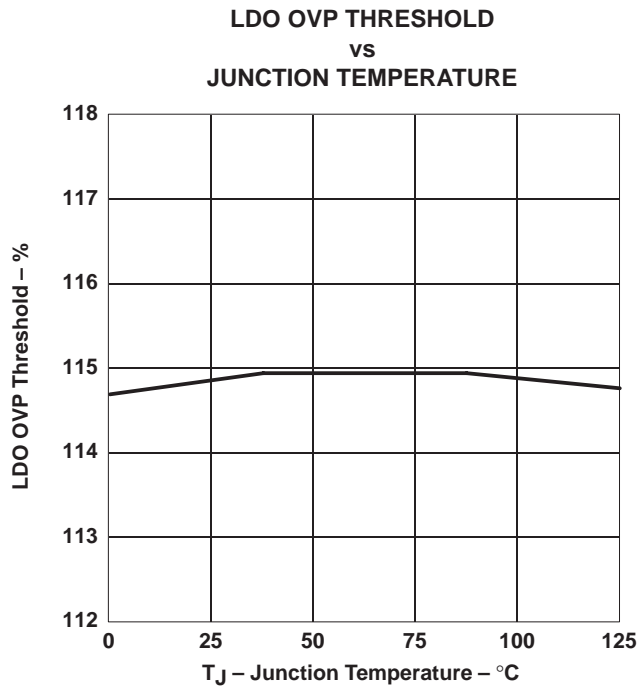

Figure 20

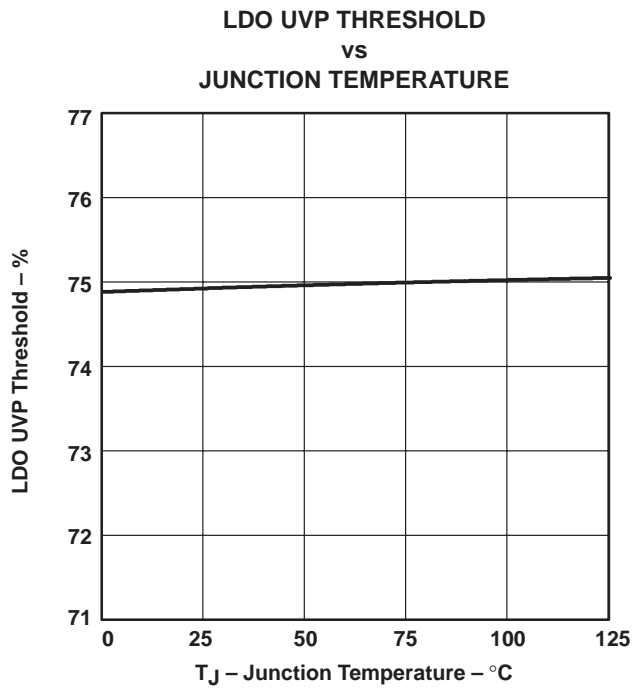
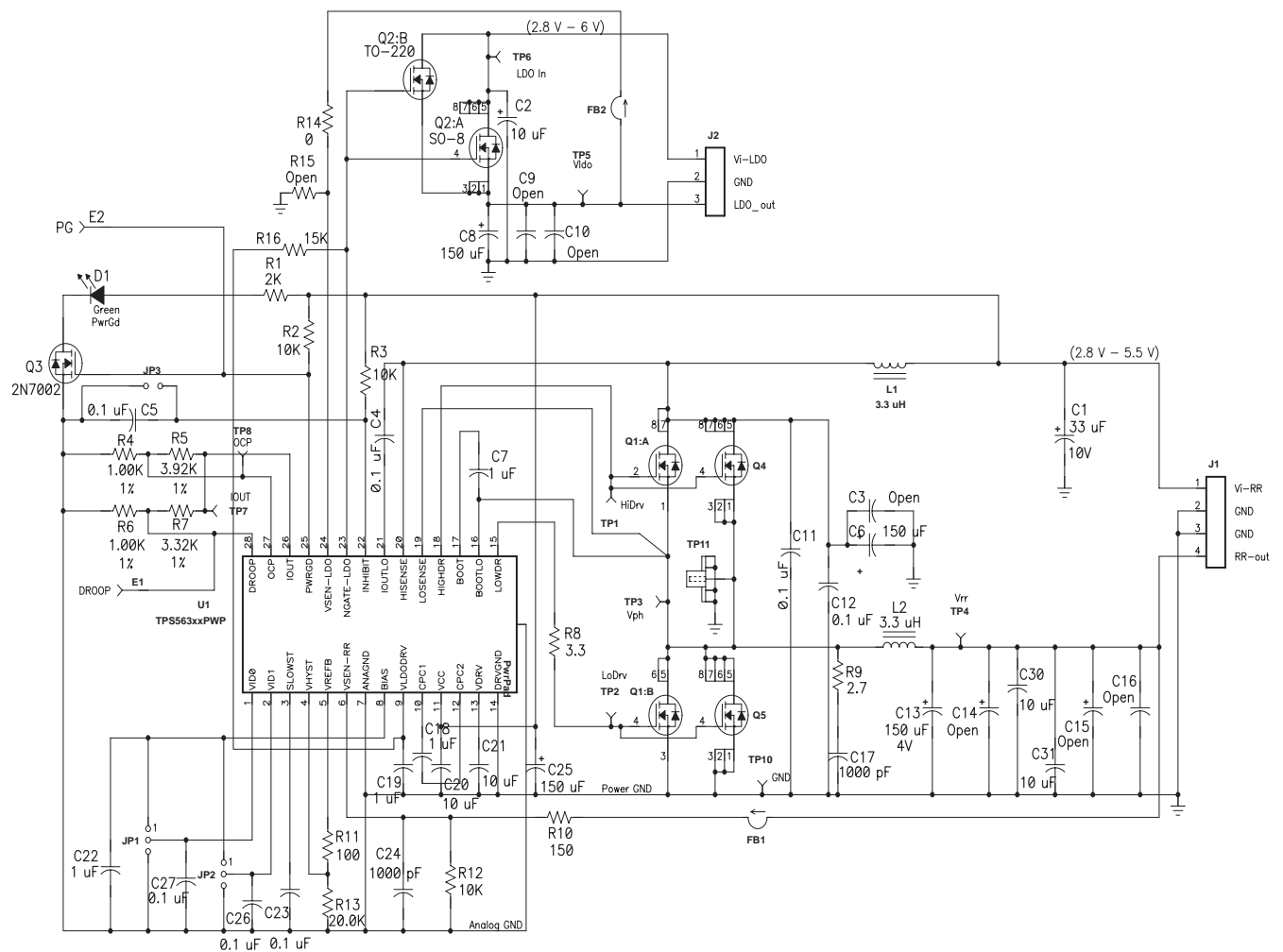

Figure 21

**APPLICATION INFORMATION**

**evaluation module**

In many DSP applications, the voltage bus powering DSP I/O also has to power peripheral circuitry. The total current is much higher than the requirement for the I/O only. This is the reason to use the high-efficiency ripple regulator to power I/O. In turn, the core power is delivered by LDO output. Since the I/O voltage is lower than the input voltage in cases such as 5-V input, but higher than the core voltage, the ripple regulator output should be used as the input voltage for LDO to achieve higher efficiency. In EVM testing, J1-4 (RR-OUT) is connected to J2-1 (VI-LDO). The test results displayed in this section are all based on this configuration.



**Figure 22. EVM Schematic**

**Table 2. EVM Input and Outputs**

$V_{IN}$	$I_{IN}$	$V_{RR}$	$I_{RR}$	$V_{LDO}$	$I_{LDO}$
5 V	4 A	3.3 V	4 A	1.8 V	0.5 A

**TPS56302**  
**DUAL-OUTPUT LOW-INPUT-VOLTAGE**  
**DSP POWER SUPPLY CONTROLLER WITH SEQUENCING**  
 SLVS289 – MARCH 2000

**APPLICATION INFORMATION**

**Table 3. Ripple Regulator Power Stage Components**

Ripple Regulator Section					
Ref Des	Function	4A (EVM Design)	8A†	12A†	20A†
C3, C6	Input bulk capacitor	C3: open C6: 150 $\mu$ F (Sanyo, 6TPB150M)	C3: 150 $\mu$ F C6: 150 $\mu$ F (Sanyo, 6TPB150M)	C3: 150 $\mu$ F C6: 150 $\mu$ F (Sanyo, 6TPB150M)	C3: 150 $\mu$ F C6: 2x150 $\mu$ F (Sanyo, 6TPB150M)
C11, C2	Input high-freq capacitor	C2: 0.1 $\mu$ F C11: 0.1 $\mu$ F (muRata GRM39X7R104K016A, 0.1 $\mu$ F, 16–V, X7R)	C2: 0.1 $\mu$ F C11: 0.1 $\mu$ F (muRata GRM39X7R104K016A, 0.1 $\mu$ F, 16–V, X7R)	C2: 0.1 $\mu$ F C11: 0.1 $\mu$ F (muRata GRM39X7R104K016A, 0.1 $\mu$ F, 16–V, X7R)	C2: 0.33 $\mu$ F C11: 0.33 $\mu$ F (muRata GRM39X7R334K016A, 0.33 $\mu$ F, 16–V, X7R)
C13, C14	Output bulk capacitor	C13: 150 $\mu$ F (Sanyo, 6TPB150M) C14: open	C13: 150 $\mu$ F (Sanyo, 6TPB150M) C14: open	C13: 150 $\mu$ F C14: 150 $\mu$ F (Sanyo, 6TPB150M)	C13: 150 $\mu$ F C14: 150 $\mu$ F (Sanyo, 6TPB150M)
C15, C30, C31	Output mid-freq capacitor	C15: open C30: 10 $\mu$ F C31: 10 $\mu$ F (muRata GRM39X7R106K016A, 10 $\mu$ F, 16–V, X7R)	C15: open C30: 10 $\mu$ F C31: 10 $\mu$ F (muRata GRM39X7R106K016A, 10 $\mu$ F, 16–V, X7R)	C15: 10 $\mu$ F C30: 10 $\mu$ F C31: 10 $\mu$ F (muRata GRM39X7R106K016A, 10 $\mu$ F, 16–V, X7R)	C15: 10 $\mu$ F C30: 10 $\mu$ F C31: 10 $\mu$ F (muRata GRM39X7R106K016A, 10 $\mu$ F, 16–V, X7R)
C16	Output high-freq capacitor	open	0.1 $\mu$ F (muRata GRM39X7R104K016A, 0.1 $\mu$ F, 16–V, X7R)	0.1 $\mu$ F (muRata GRM39X7R104K016A, 0.1 $\mu$ F, 16–V, X7R)	0.1 $\mu$ F (muRata GRM39X7R104K016A, 0.1 $\mu$ F, 16–V, X7R)
L1	Input filter	3.3 $\mu$ H Coilcraft DO3316P–332, 5.4 A	3.3 $\mu$ H Coilcraft DO3316P–332, 5.4 A	1.5 $\mu$ H Coilcraft DO3316P–152, 6.4 A	1 $\mu$ H Coiltronics UP3B–1R0, 12.5–A
L2	Output filter	3.3 $\mu$ H Coilcraft DO3316P–332, 5.4 A	3.3 $\mu$ H Coilcraft DO5022P–332HC, 10 A	1.5 $\mu$ H Coilcraft DO5022P–152HC, 15 A	3.3 $\mu$ H Micrometals, T68–8/90 Core w/7T, #16, 25 A
R8	Low side gate resistor	10 $\Omega$	10 $\Omega$	5.1 $\Omega$	5.1 $\Omega$
Q1A, Q4	Power switch	Q1A: Dual FET IRF7311	Q4: IRF7811	Q4: 2xIRF7811	Q4: 2xIRF7811
Q1B, Q5	Synchronous switch	Q1B: Dual FET IRF7311	Q5: IRF7811	Q5: 2xIRF7811	Q5: 2xIRF7811

† Position available on the EVM board

The values listed in Table 3 are recommendations based on actual test circuits. Many variations of the above are possible based upon the desires and/or requirements of the user. Performance of the circuit is equally, if not more, dependent upon the layout than on the specific components, as long as the device parameters are not exceeded. Fast-response, low-noise circuits require critical attention to the layout details.

## APPLICATION INFORMATION

**Table 4. LDO Power Stage Components**

LDO Section				
Ref. Des	Part	V <sub>IN</sub>	V <sub>OUT</sub>	Description
Q2:A	IRF7811(EVM) or Si4410, IRF7413‡ FDS6680	V <sub>IN</sub>	V <sub>IN</sub> - V <sub>DROPOUT</sub> †	Used as a power distribution switch for LDO output control
Q2:A	IRF9410, Si9410‡			Low cost solution for low LDO output current (V <sub>IN</sub> -V <sub>OUT</sub> )*I <sub>OUT</sub> < 1 W
Q2:A	IRF7811‡			Higher current and still surface mount 1 W < (V <sub>IN</sub> -V <sub>OUT</sub> )*I <sub>OUT</sub> < 2 W
Q2: B	IRLZ24N‡			High output current requiring heat sink. Low cost but through-hole package. (V <sub>IN</sub> -V <sub>OUT</sub> )*I <sub>OUT</sub> > 2 W

† V<sub>DROPOUT</sub> = I<sub>OUT</sub> × R<sub>DS(on)</sub>. It should be as small as possible.

‡ Position available on the EVM board

### frequency calculation

With hysteretic control, the switching frequency is a function of the input voltage, the output voltage, the hysteresis window, the delay of the hysteresis comparator and the driver, the output inductance, the resistance in the output inductor, the output capacitance, the ESR and ESL in the output capacitor, the output current, and the turnon resistance of high-side and low-side MOSFET. It is a very complex equation if everything is included. To make it more useful to designers, a simplified equation is developed that considers only the most influential factors. The tolerance of the result for this equation is about 30%:

$$f_s = \frac{V_{OUT} \times (V_{IN} - V_{OUT}) \times \left[ \text{ESR} - \frac{(250 \times 10^{-9} + T_d)}{C_{out}} \right]}{V_{IN} \times \left( V_{IN} \times \text{ESR} \times (250 \times 10^{-9} + T_d) + V_{hys} \times L_{OUT} - \text{ESL} \times V_{IN} \right)}$$

Where  $f_s$  is the switching frequency (Hz);  $V_{OUT}$  is the output voltage (V);  $V_{IN}$  is the input voltage (V);  $C_{OUT}$  is the output capacitance; ESR is the equivalent series resistance in the output capacitor ( $\Omega$ ); ESL is the equivalent series inductance in the output capacitor (H);  $L_{OUT}$  is the output inductance (H);  $T_d$  is output feedback RC filter time constant (S);  $V_{hys}$  is the hysteresis window (V).

### output voltage setpoint calculation

In some applications, the required output voltage is different from the VID reference voltage. In this case, external voltage divider can be used for the setpoint adjustment. The voltage divider is composed of two resistors. The equation for the setpoint is:

$$R_{bottom} = \frac{R_{top} \times V_R}{V_O - V_R}$$

Where  $V_R$  is the reference voltage;  $V_O$  is the required output voltage setpoint.  $V_R$  should be lower than  $V_O$ . In EVM design, the top resistor is R14 for the LDO output, or R10 for ripple regular output; the bottom resistor is R15 for LDO output, or R12 for ripple regulator output.

## APPLICATION INFORMATION

### hysteresis window

The changeable hysteresis window in TPS56302 is used for switching frequency and output voltage ripple adjustment. The hysteresis window setup is decided by a two-resistor voltage divider on VREFB and VHYST pin. Two times the voltage drop on the top resistor is the hysteresis window. The formula is shown in the following:

$$V_{\text{hyswindow}} = 2 \times V_{\text{REFB}} \times \left( 1 - \frac{R_{13}}{R_{11} + R_{13}} \right)$$

Where  $V_{\text{hyswindow}}$  is the hysteresis window (V);  $V_{\text{REFB}}$  is the regulated voltage from VREVB (pin 5); R11 is the top resistor in the voltage divider; R13 is the bottom resistor in the voltage divider. The maximum hysteresis window is 60 mV.

### slow-start

Slow-start reduces the start-up stresses on the power-stage components and reduces the input current surge. The minimum slow-start time is limited to 1 ms due to the power good function deglitch time. Slow-start timing is dependent on the timing capacitor value on the slow-start pin and the total resistance on VREFB. The following formula can be used for setting the slow-start timing:

$$T_{\text{SLOW-START}} = 5 \times C_{\text{SLOW-START}} \times R_{\text{VREFB}}$$

$T_{\text{SLOW-START}}$  is the slow-start time;  $C_{\text{SLOW-START}}$  is the capacitor value on SLOWST (pin 3).  $R_{\text{VREFB}}$  is the total resistance on VREFB (pin 5).

### current limit

Current limit is implemented using the on-resistance of the upper FETs as the sensing elements. The IOOUT signal is used for the current limit and the droop function. The voltage at IOOUT at the output current trip point will be:

$$V_{\text{IOOUT}} = R_{\text{ON}} \times I_{\text{O}} \times 2$$

$R_{\text{ON}}$  is the high-side on-time resistance;  $I_{\text{O}}$  is the output current. The current limit is calculated by using the equation:

$$R_5 = \frac{R_4 \times \left( I_{\text{O(MAX)}} \times 2 \times R_{\text{ON}} - 0.125 \right)}{0.125}$$

Where R4 is the bottom resistor in the voltage divider on OCP pin, and R5 is the top resistor;  $I_{\text{O(MAX)}}$  is the maximum current allowed;  $R_{\text{ON}}$  is the high-side FET on-time resistance.

Since the FET on-time resistance varies according to temperature, the current limit is basically for catastrophic failure.



## APPLICATION INFORMATION

### droop compensation

Droop compensation with the offset resistor divider from  $V_{OUT}$  to the  $V_{SENSE}$  is used to keep the output voltage in range during load transients by increasing the output voltage setpoint toward the upper tolerance limit during light loads and decreasing the voltage setpoint toward the lower tolerance limit during heavy loads. This allows the output voltage to swing a greater amount and still remain within the tolerance window. The maximum droop voltage is set with R6 and R7:

$$V_{DROOP(max)} = V_{IOUT(max)} \times \frac{R6}{R6 + R7}$$

Where  $V_{DROOP(max)}$  is the maximum droop voltage;  $V_{IOUT(max)}$  is the maximum  $V_{IOUT}$  that reflects the maximum output current (full load); R6 is the bottom resistor of the divider connected to the DROOP pin, R7 is the top resistor.

The offset voltage is set to be half of the maximum droop voltage higher than the nominal output voltage, so the whole droop voltage range is symmetrical to the nominal output voltage. The formula for setting the offset voltage is:

$$V_{OFFSET} = \frac{1}{2} \times V_{DROOP(max)} = V_O \times \left( \frac{R12}{R10 + R12} \right)$$

Where  $V_{OFFSET}$  is the desired offset voltage;  $V_{DROOP(max)}$  is the droop voltage at full load;  $V_O$  is the nominal output voltage; R10 is the top resistor of the offset resistor divider, and R12 is the bottom one.

Therefore, with the setup above, at light load, the output voltage is:

$$V_{O(NO\ LOAD)} = V_{O(nom)} + V_{OFFSET} = V_{O(nom)} + \frac{1}{2} \times V_{DROOP}$$

And, at full load, the output voltage is:

$$V_{O(FULL\ LOAD)} = V_{O(nom)} - V_{OFFSET} = V_{O(nom)} - \frac{1}{2} \times V_{DROOP}$$

### output inductor ripple current

The output inductor current ripple can affect not only the efficiency, but also the output voltage ripple. The equation for calculating the inductor current ripple is exhibited in the following:

$$I_{ripple} = \frac{V_{IN} - V_{OUT} - I_{OUT} \times (r_{DS(on)} + R_L)}{L_{OUT}} \times D \times T_s$$

Where  $I_{ripple}$  is the peak-to-peak ripple current (A) through the inductor;  $V_{IN}$  is the input voltage (V);  $V_{OUT}$  is the output voltage (V);  $I_{OUT}$  is the output current;  $r_{DS(on)}$  is the on-time resistance of MOSFET ( $\Omega$ );  $R_L$  is the output inductor equivalent series resistance; D is the duty cycle; and  $T_s$  is the switch cycle (S). From the equation, it can be seen that the current ripple can be adjusted by changing the output inductor value.

Example:

$$V_{IN} = 5\text{ V}; V_{OUT} = 1.8\text{ V}; I_{OUT} = 5\text{ A}; r_{DS(on)} = 10\text{ m}\Omega; R_L = 5\text{ m}\Omega; D = 0.36; T_s = 5\text{ }\mu\text{s}; L_{OUT} = 6\text{ }\mu\text{H}$$

Then, the ripple  $I_{ripple} = 1\text{ A}$ .

## APPLICATION INFORMATION

### output capacitor RMS current

Assuming the inductor ripple current totally goes through the output capacitor to ground, the RMS current in the output capacitor can be calculated as:

$$I_{O(rms)} = \frac{\Delta I}{\sqrt{12}}$$

Where  $I_{O(rms)}$  is the maximum RMS current in the output capacitor (A);  $\Delta I$  is the peak-to-peak inductor ripple current (A).

Example:

$$\Delta I = 1 \text{ A, so } I_{O(rms)} = 0.29 \text{ A}$$

### input capacitor RMS current

The input capacitor RMS current is important for input capacitor design. Assuming the input ripple current totally goes into the input capacitor to the power ground, the RMS current in the input capacitor can be calculated as:

$$I_{I(rms)} = \sqrt{I_O^2 \times D \times (1 - D) + \frac{1}{12} \times D \times I_{ripple}^2}$$

Where  $I_{I(rms)}$  is the input RMS current in the input capacitor (A);  $I_O$  is the output current (A);  $I_{ripple}$  is the peak-to-peak output inductor ripple current;  $D$  is the duty cycle. From the equation, it can be seen that the highest input RMS current usually occurs at the lowest input voltage, so it is the worst case design for input capacitor ripple current.

Example:

$$I_O = 5 \text{ A; } D = 0.36; I_{ripple} = 1 \text{ A,}$$
$$\text{Then, } I_{I(rms)} = 2.46 \text{ A}$$

### layout and component value consideration

Good power supply results will only occur when care is given to proper design and layout. Layout and component value will affect noise pickup and generation and can cause a good design to perform with less than expected results. With a range of current from milliamps to tens or even hundreds of amps, good power supply layout and component selection, especially for a fast ripple controller, is much more difficult than most general PCB design. The general design should proceed from the switching node to the output, then back to the driver section, and, finally, to placing the low-level components. In the following list are several specific points to consider before layout and component selection for TPS56302:

1. All sensitive analog components should be referenced to ANAGND. These include components connected to SLOWST, DROOP, IOUT, OCP, VSENSE, VREFB, VHYST, BIAS, and LOSENSE/LOHIB.
2. The input voltage range for TPS56302 is low from 2.8-V to 5.5-V, so it has a voltage tripler (charge pump) inside to deliver proper voltage for internal circuitry. To avoid any possible noise coupling, a low ESR capacitor on  $V_{CC}$  is recommended.
3. For the same reason in Item 2, the ANAGND and DRVGND should be connected as close as possible to the IC.
4. The bypass capacitor should be placed close to the TPS56302.

**APPLICATION INFORMATION**

**layout and component value consideration (continued)**

5. When configuring the high-side driver as a boot-strap driver, the connection from BOOTLO to the power FETs should be as short and as wide as possible. LOSENSE/LOHIB should have a separate connection to the FETs since BOOTLO will have large peak current flowing through it.
6. The bulk storage capacitors across  $V_{IN}$  should be placed close to the power FETs. High-frequency bypass capacitors should be placed in parallel with the bulk capacitors and connected close to the drain of the high-side FET and to the source of the low-side FET.
7. HISENSE and LOSENSE/LOHIB should be connected very close to the drain and source, respectively, of the high-side FET. HISENSE and LOSENSE/LOHIB should be routed very close to each other to minimize differential-mode noise coupling to these traces. Ceramic decoupling capacitors should be placed close to where HISENSE connects to  $V_{IN}$ , to reduce high-frequency noise coupling on HISENSE.

The EVM board (SLVP-139) is used in the test. The test results are shown in the following.

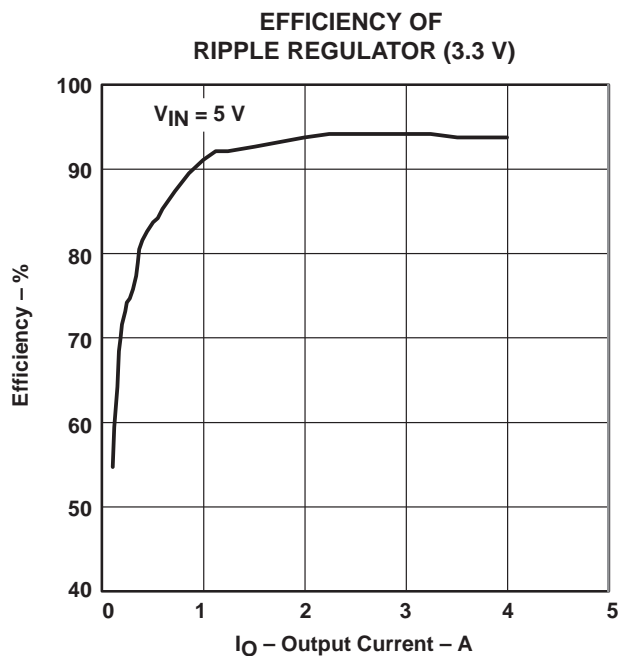

**Figure 23**

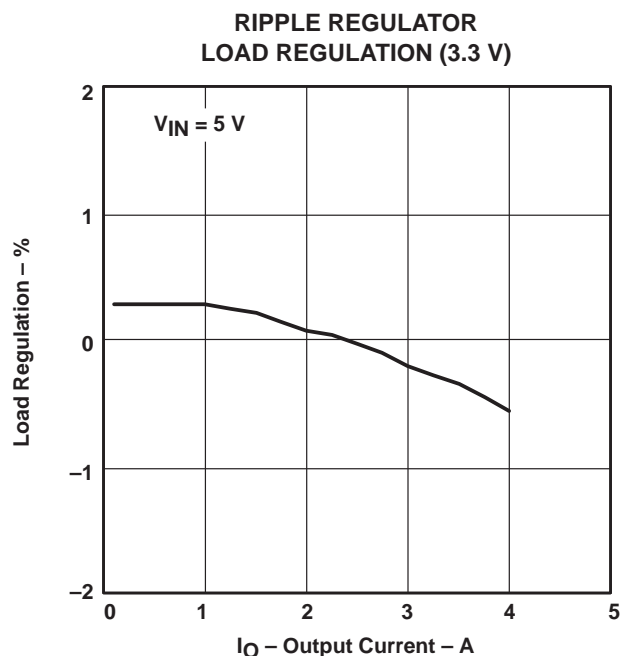

**Figure 24**

APPLICATION INFORMATION

RIPPLE REGULATOR  
 LINE REGULATION (3.3 V)

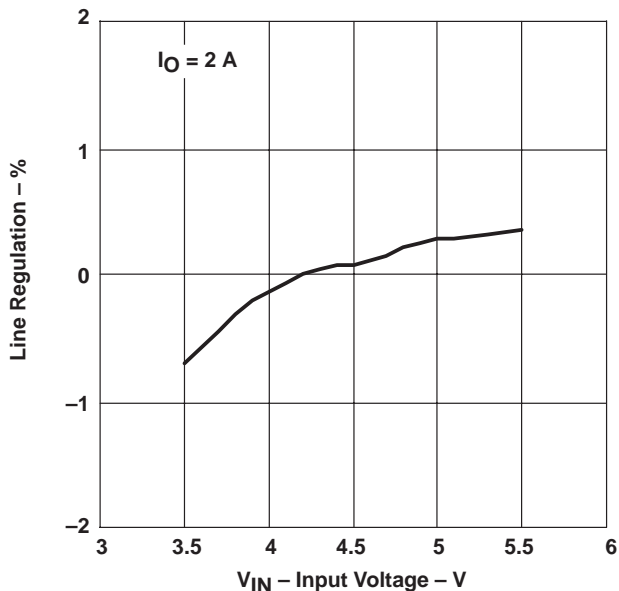

Figure 25

LDO LOAD REGULATION (1.8 V)

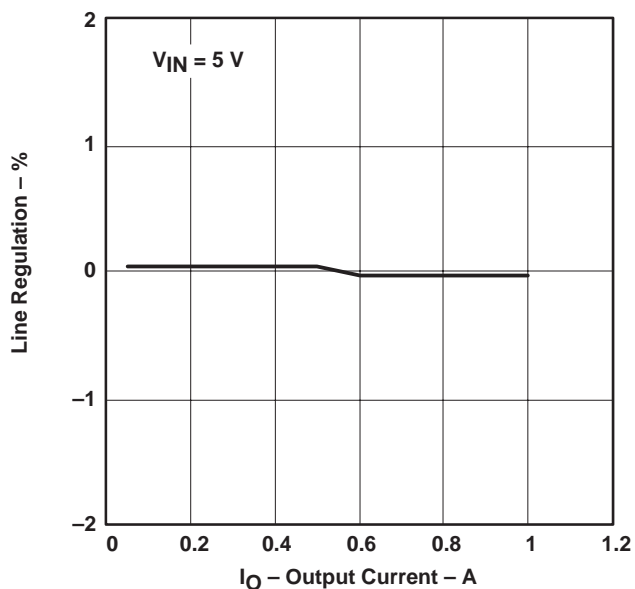

Figure 26

DROOP COMPENSATION EFFECT

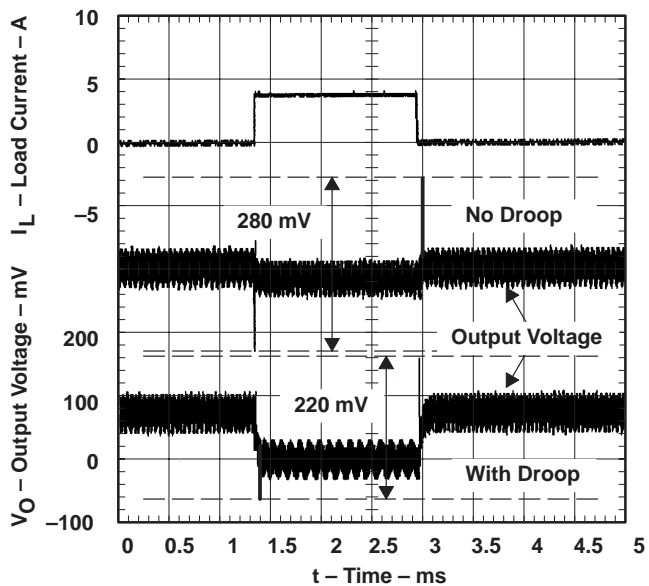

Figure 27

SLOW-START

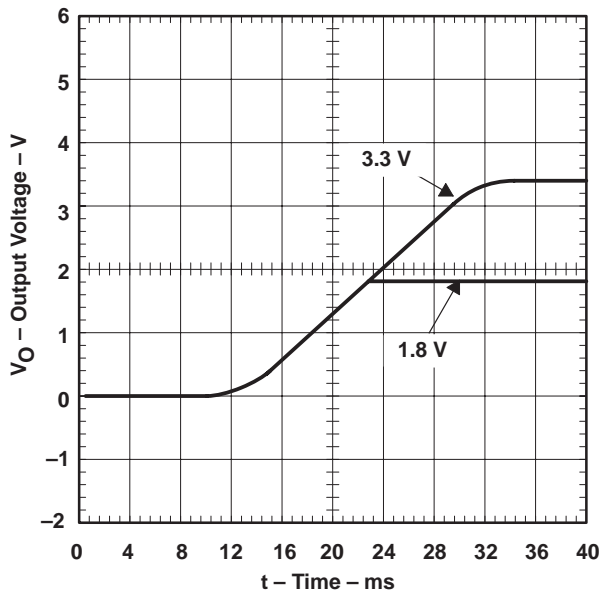

Figure 28

APPLICATION INFORMATION

layouts

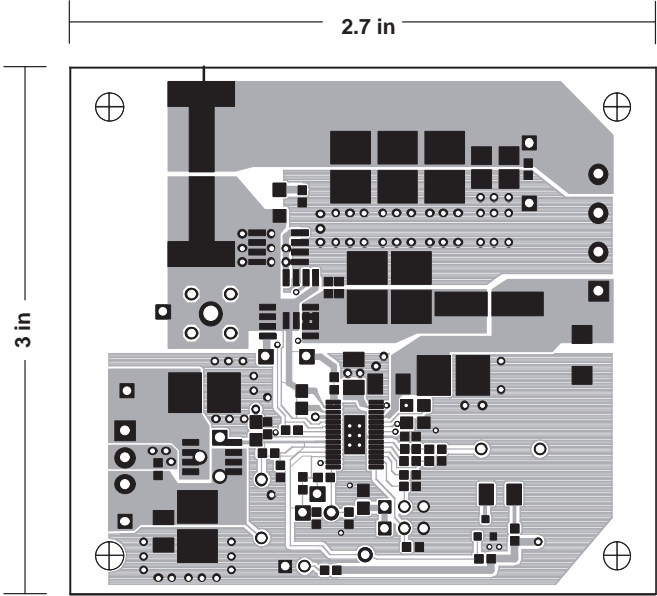

Figure 29. Top Layer

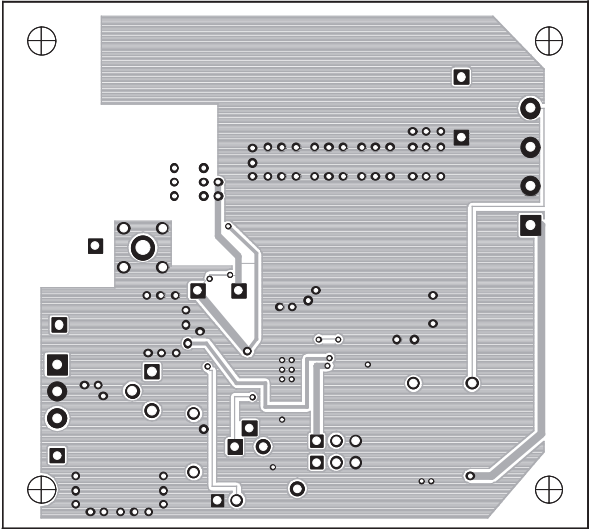

Figure 30. Bottom Layer (Top View)

**TPS56302**  
**DUAL-OUTPUT LOW-INPUT-VOLTAGE**  
**DSP POWER SUPPLY CONTROLLER WITH SEQUENCING**  
 SLVS289 – MARCH 2000

**APPLICATION INFORMATION**

**bill of materials**

REF	PN	Description	MFG	Size
C1	10TPA33M	Capacitor, POSCAP, 33 $\mu$ F, 10 V	Sanyo	C
C2, C20, C21, C30, C31	Std	Capacitor, Ceramic, 10 $\mu$ F, 16 V	Sanyo	1210
C3, C6, C8, C13, C25	6TPB150M	Capacitor, POSCAP, 150 $\mu$ F, 6 V	Sanyo	D
C4, C5, C11, C12, C23, C26, C27,	Std	Capacitor, Ceramic, 0.1 $\mu$ F, 16 V	Sanyo	603
C7, C22	Std	Capacitor, Ceramic, 1 $\mu$ F, 16 V	Sanyo	805
C9	Std	Open		1210
C10, C16	Std	Open		603
C14, C15	Std	Open		D
C17, C24	Std	Capacitor, Ceramic, 1000 pF, 16 V	Sanyo	603
C18, C19	Std	Capacitor, Ceramic, 1 $\mu$ F, 16 V	Sanyo	805
D1	SML-LX2832G	Diode, LED, Green, 2.1 V SM	Lumwx	1210
L1, L2	DO3316P-332	Inductor, 3.3 $\mu$ H, 5.4 A	Coilcraft	0.5 $\times$ 0.37 in
J1	ED2227	Terminal Block, 4-pin, 15 A, 5.08 mm	OST	5.08 mm
J2	ED1515	Terminal Block, 3-pin, 6 A, 3.5 mm	OST	n, 6 A,
JP1, JP2	S1132-3-ND	Header, Right straight, 3-pin, 0.1 ctrs, 0.3" pins	Sullins	#S1132-3-ND
JP1shunt	929950-00-ND	Shunt jumper, 0.1" (for JP1)	3M	0.1"
J3	S1132-2-ND	Header, Right straight, 2-pin, 0.1 ctrs, 0.3" pins	Sullins	#S1132-2-ND
Q1		Open		SO-8
Q2:A, Q4, Q5	IRF7811	MOSFET, N-ch, 30 V, 10 m $\Omega$		SO-8
Q2:B		Open		TO-220
Q3	2N7002DICT-N	MOSFET, N-ch, 115 mA, 1.2 $\Omega$	Diodes, Inc.	TO-236
R3	std	Resistor, 10 kohms, 5 %		603
R4	std	Resistor, 1 kohms, 1%		603
R5	std	Resistor, 0 ohms, 1%		603
R6	std	Resistor, 1 kohms, 1%		603
R7	std	Resistor, 3.32 kohms, 1%		603
R8	std	Resistor, 10 ohms, 5 %		603
R9	std	Resistor, 2.7 ohms, 5 %		1206
R10	std	Resistor, 150 ohms, 5 %		603
R11	std	Resistor, 100 ohms, 1 %		603
R12	std	Resistor, 10 kohms, 5 %		603
R13	std	Resistor, 20.0 kohms, 1 %		603
R14	std	Resistor, 0 ohms, 5%		603
R15	std	Resistor, open		603
R16	std	Resistor, 15 kohms, 5 %		805
TP1-TP10	240-345	Test Point, Red	Farnell	
TP11	131-4244-00	Adaptor, 3.5-mm probe clip (or 131-5031-00)	Tektronix	
U1	TPS56302PWP	Dual controller		TSSOP-28pin

**APPLICATION INFORMATION**

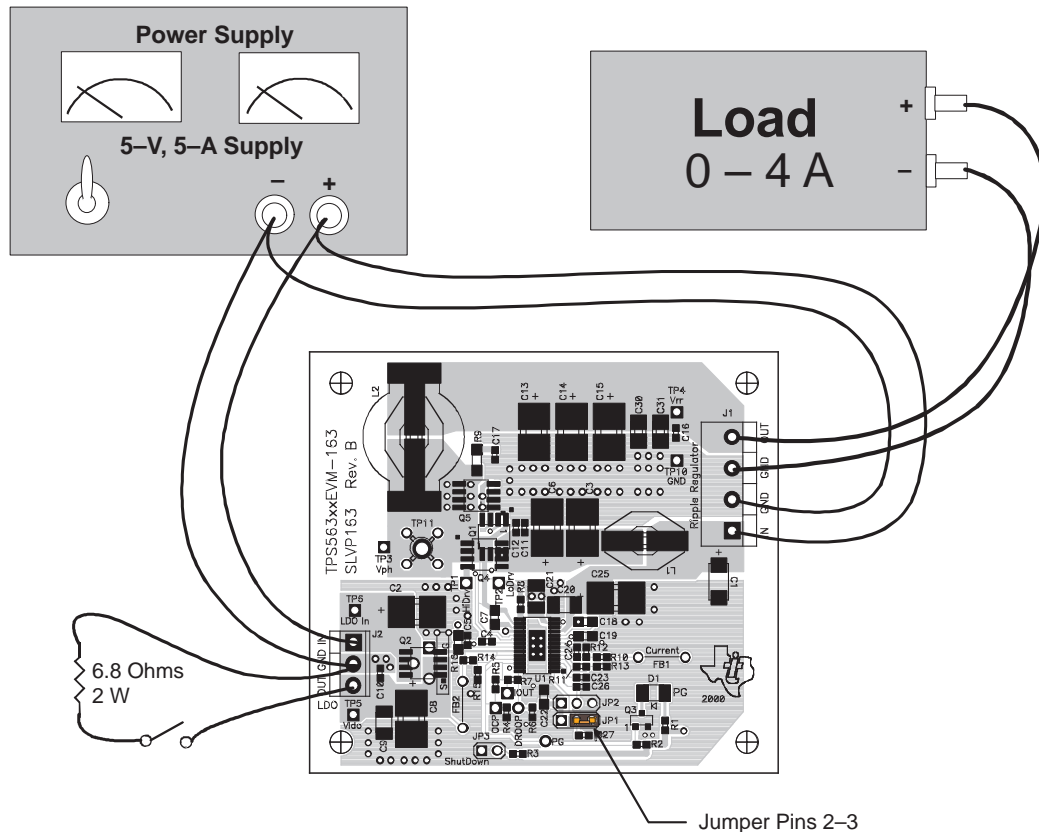

NOTE A: All wire pairs should be twisted.

**Figure 31. Test Setup**

APPLICATION INFORMATION

DSP power application

In DSP power applications, TPS56302 is used in the applications that require more current for peripheral and DSP I/O. The power good (PG) output can be used for monitoring or controlling as an optional function. In the EVM schematic, Q3, D1, R1, and R2 are the circuit to show this function.

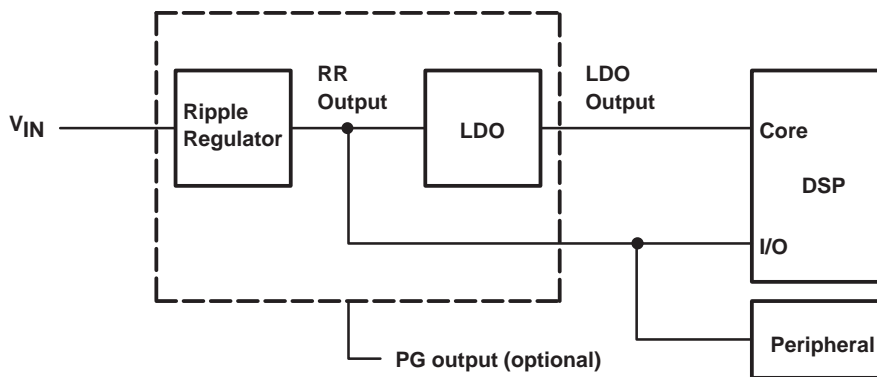

Figure 32. TPS56302 For High Peripheral Current DSP Application

TPS56300 is used in the applications that require high current for core, but low current for I/O. Another important feature is that, if the input voltage is the same as the LDO output, the LDO switch acts as a distribution switch to control the on/off of the LDO output.

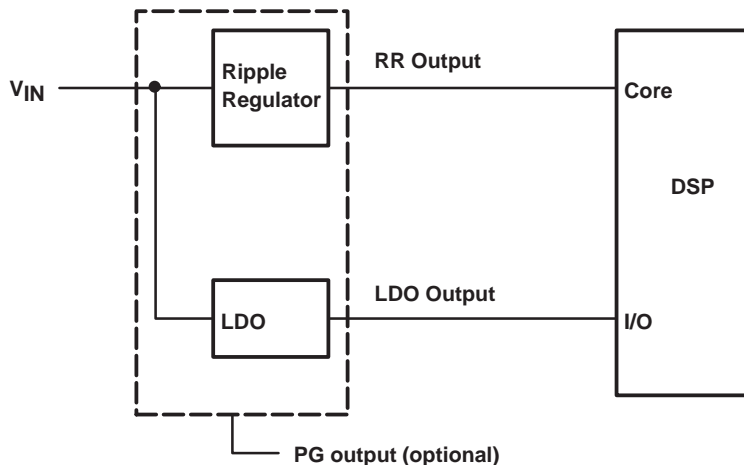

Figure 33. TPS56300 For On/Off Control DSP Application



TPS56302  
**DUAL-OUTPUT LOW-INPUT-VOLTAGE  
 DSP POWER SUPPLY CONTROLLER WITH SEQUENCING**  
 SLVS289 – MARCH 2000

**MECHANICAL DATA**

**PWP (R-PDSO-G\*\*)**

**PowerPAD™ PLASTIC SMALL-OUTLINE PACKAGE**

20-PIN SHOWN

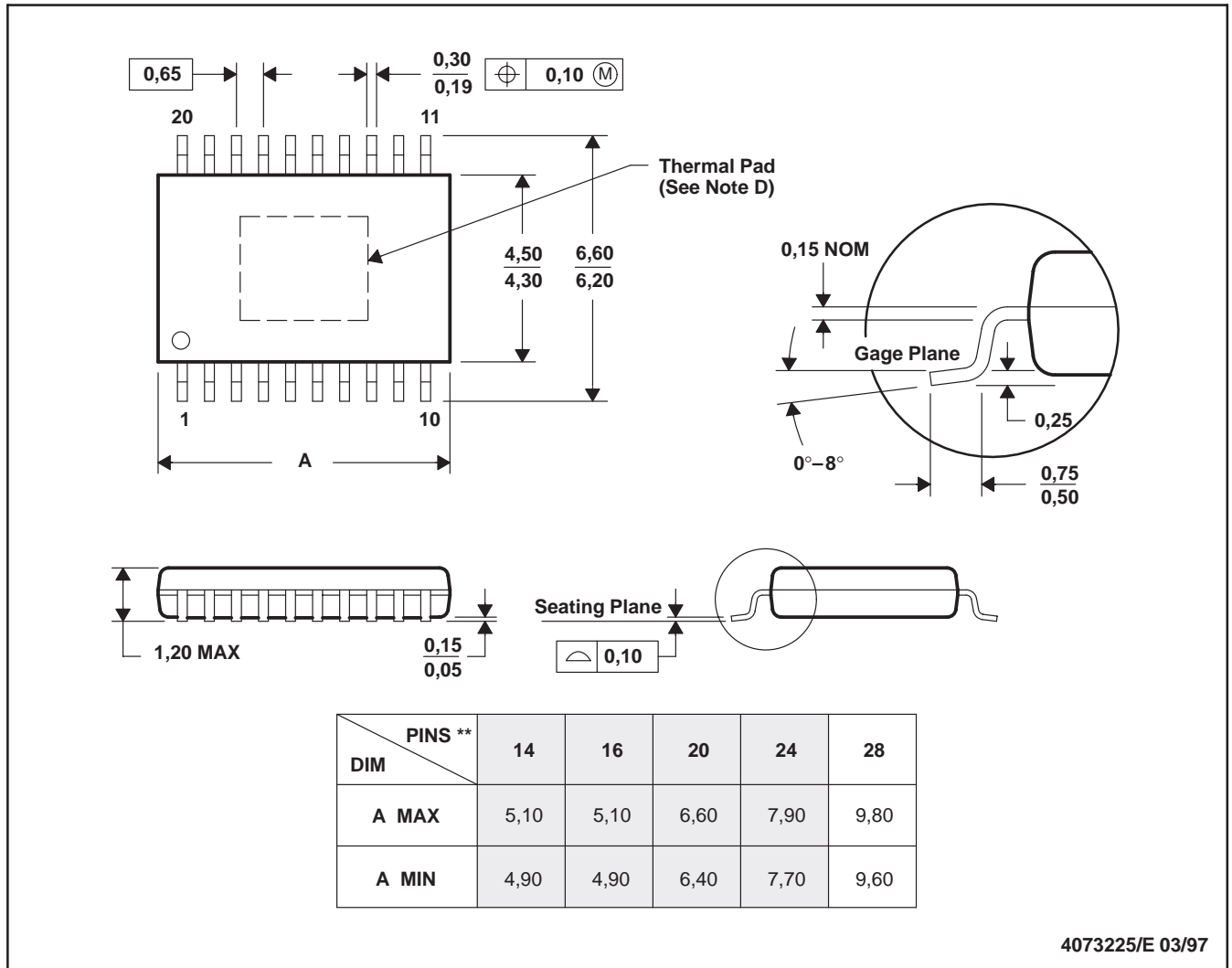

- NOTES: A. All linear dimensions are in millimeters.  
 B. This drawing is subject to change without notice.  
 C. Body dimensions do not include mold flash or protrusions.  
 D. The package thermal performance may be enhanced by bonding the thermal pad to an external thermal plane. This pad is electrically and thermally connected to the backside of the die and possibly selected leads.  
 E. Falls within JEDEC MO-153

## **IMPORTANT NOTICE**

Texas Instruments and its subsidiaries (TI) reserve the right to make changes to their products or to discontinue any product or service without notice, and advise customers to obtain the latest version of relevant information to verify, before placing orders, that information being relied on is current and complete. All products are sold subject to the terms and conditions of sale supplied at the time of order acknowledgment, including those pertaining to warranty, patent infringement, and limitation of liability.

TI warrants performance of its semiconductor products to the specifications applicable at the time of sale in accordance with TI's standard warranty. Testing and other quality control techniques are utilized to the extent TI deems necessary to support this warranty. Specific testing of all parameters of each device is not necessarily performed, except those mandated by government requirements.

Customers are responsible for their applications using TI components.

In order to minimize risks associated with the customer's applications, adequate design and operating safeguards must be provided by the customer to minimize inherent or procedural hazards.

TI assumes no liability for applications assistance or customer product design. TI does not warrant or represent that any license, either express or implied, is granted under any patent right, copyright, mask work right, or other intellectual property right of TI covering or relating to any combination, machine, or process in which such semiconductor products or services might be or are used. TI's publication of information regarding any third party's products or services does not constitute TI's approval, warranty or endorsement thereof.