



8A LDO 5-Pin Adjustable Linear Regulator

Description

This new very low dropout regulator is designed to power the next generation of advanced microprocessors. To achieve very low dropout, the internal pass transistor is powered separately from the control circuitry. Furthermore, with the control and power inputs tied together, this device can be used in single supply configuration and still offer a better dropout voltage than conventional PNP-NPN based LDO regulators. In this mode the dropout is determined by the minimum control voltage.

It is supplied in a five-terminal TO-220 package, which allows for the implementation of a remote-sense pin permitting very accurate regulation of output voltage directly at the load, where it counts, rather than at the regulator. This remote sensing feature virtually eliminates output voltage variations due to load changes and resistive voltage drops.

Typical load regulation measured at the sense pin is 1mV for an output voltage of 2.5V with a load step of 10mA to 8A.

The very fast transient loop response easily meets the needs of the latest microprocessors. In addition, a small capacitor on the Adjust pin will further improve the transient capabilities.

Internal protection circuitry provides for "bust-proof" operation, similar to three-terminal regulators. This circuitry, which includes over-current, short circuit, supply sequencing and overtemperature protection, will self protect the regulator under all fault conditions.

The CS5258-1 is ideal for generating a secondary 2 - 2.5V low voltage supply on a motherboard where both 5V and 3.3V are already available.

Features

- 1.25V to 5V V_{OUT} at 8A
- V_{POWER} Dropout <0.4V @ 8A
- $V_{CONTROL}$ Dropout <1.15V @ 8A
- 1.5% Trimmed Reference
- Fast Transient Response
- Remote Voltage Sensing
- Thermal Shutdown
- Current Limit
- Short Circuit Protection
- Backwards Compatible with 3-pin Regulators

Package Options

5 Lead TO-220

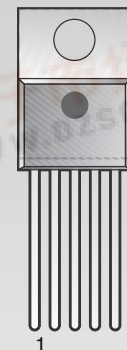

1. V_{SENSE}
 2. Adjust
 3. V_{OUT}
 4. $V_{CONTROL}$
 5. V_{POWER}
- Tab = V_{OUT}

Applications Diagram

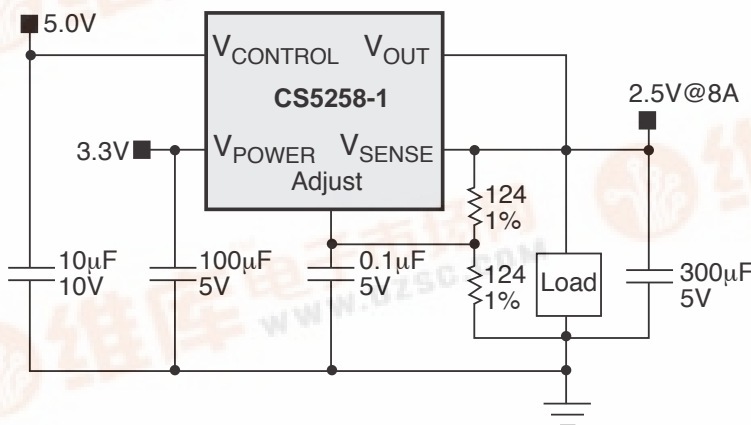

Absolute Maximum Ratings

V _{POWER} Input Voltage	6V
V _{CONTROL} Input Voltage	13V
Operating Junction Temperature Range.....	0°C ≤ T _J ≤ 150°C
Storage Temperature Range.....	-65°C to +150°C
ESD Damage Threshold.....	2kV
Lead Temperature Soldering	
Wave Solder (through hole styles only)	10 sec. max, 260°C peak

Electrical Characteristics: 0°C ≤ T_A ≤ 70°C, 0°C ≤ T_J ≤ 150°C, V_{SENSE} = V_{OUT} and V_{Adj} = 0V unless otherwise specified.

PARAMETER	TEST CONDITIONS	MIN	TYP	MAX	UNIT
Reference Voltage	V _{CONTROL} = 2.75V to 12V, V _{POWER} = 2.15V to 5.5V, 10mA ≤ I _{OUT} ≤ 8A	1.234 (-1.5%)	1.253	1.272 (+1.5%)	V
Line Regulation	V _{CONTROL} = 2.5V to 12V, V _{POWER} = 1.75V to 5.5V, I _{OUT} = 10mA		.02	.20	%
Load Regulation (Note 3)	V _{CONTROL} = 2.75V, V _{POWER} = 2.15V, I _{OUT} = 10mA to 8A, with remote sense		.04	.20	%
Minimum Load Current (Note 1)	V _{CONTROL} = 5V, V _{POWER} = 3.3V, ΔV _{OUT} = +1%		5	10	mA
Control Pin Current (Note 2)	V _{CONTROL} = 2.75V, V _{POWER} = 2.15V, I _{OUT} = 100mA V _{CONTROL} = 2.75V, V _{POWER} = 2.15V, I _{OUT} = 4A V _{CONTROL} = 2.75V, V _{POWER} = 1.75V, I _{OUT} = 4A V _{CONTROL} = 2.75V, V _{POWER} = 2.15V, I _{OUT} = 8A		6 30 33 80	10 60 70 180	mA
Adjust Pin Current	V _{CONTROL} = 2.75V, V _{POWER} = 2.15V, I _{OUT} = 10mA		60	120	μA
Current Limit	V _{CONTROL} = 2.75V, V _{POWER} = 2.15V, ΔV _{OUT} = -1.5%	8.1	10.0		A
Short Circuit Current	V _{CONTROL} = 2.75V, V _{POWER} = 2.15V, V _{OUT} = 0V	6.0	9.0		A
Ripple Rejection (Note 3)	V _{CONTROL} = V _{POWER} = 3.25V Avg, V _{Ripple} = 1V _{P-P} @ 120Hz, I _{OUT} = 4A, C _{ADJ} = 0.1μF	60	80		dB
Thermal Regulation	30ms Pulse, T _A = 25°C		0.002		% / W
V _{CONTROL} Dropout Voltage (Minimum V _{CONTROL} -V _{OUT}) (Note 4)	V _{POWER} = 2.15V, I _{OUT} = 100mA V _{POWER} = 2.15V, I _{OUT} = 1A V _{POWER} = 2.15V, I _{OUT} = 2.75A V _{POWER} = 2.15V, I _{OUT} = 4A V _{POWER} = 2.15V, I _{OUT} = 8A		1.00 1.00 1.00 1.00 1.15	1.15 1.15 1.15 1.15 1.30	V
V _{POWER} Dropout Voltage (Minimum V _{POWER} -V _{OUT}) (Note 4)	V _{CONTROL} = 2.75V, I _{OUT} = 100mA V _{CONTROL} = 2.75V, I _{OUT} = 1A V _{CONTROL} = 2.75V, I _{OUT} = 2.75A V _{CONTROL} = 2.75V, I _{OUT} = 4A V _{CONTROL} = 2.75V, I _{OUT} = 8A		.10 .15 .20 .26 .40	.15 .20 .30 .40 .70	V
RMS Output Noise	Freq = 10Hz to 10kHz, T _A = 25°C		0.003		% V _{OUT}
Temperature Stability			0.5		%
Thermal Shutdown (Note 5)		150	180	210	°C
Thermal Shutdown Hysteresis			25		°C
V _{CONTROL} Supply Only Output Current	V _{CONTROL} = 13V, V _{POWER} not connected, V _{ADJUST} = V _{OUT} = V _{SENSE} = 0V			50	mA

Electrical Characteristics: $0^{\circ}\text{C} \leq T_A \leq 70^{\circ}\text{C}$, $0^{\circ}\text{C} \leq T_J \leq 150^{\circ}\text{C}$, $V_{\text{SENSE}} = V_{\text{OUT}}$ and $V_{\text{Adj}} = 0\text{V}$ unless otherwise specified.

PARAMETER	TEST CONDITIONS	MIN	TYP	MAX	UNIT
V_{POWER} Supply Only Output Current	$V_{\text{POWER}} = 6\text{V}$, V_{CONTROL} not connected, $V_{\text{ADJUST}} = V_{\text{OUT}} = V_{\text{SENSE}} = 0\text{V}$		0.1	1	mA

- Note 1: The minimum load current is the minimum current required to maintain regulation. Normally the current in the resistor divider used to set the output voltage is selected to meet the minimum load current requirement.
- Note 2: The control pin current is the drive current required for the output transistor. This current will track output current with roughly a 1:100 ratio. The minimum value is equal to the quiescent current of the device.
- Note 3: This parameter is guaranteed by design and is not 100% production tested.
- Note 4: Dropout is defined as either minimum control voltage (V_{CONTROL}) or minimum power voltage (V_{POWER}) to output voltage differential required to maintain 1.5% regulation at a particular load current.
- Note 5: This parameter is guaranteed by design, but not parametrically tested in production. However, a 100% thermal shutdown functional test is performed on each part.

Package Pin Description

PACKAGE PIN #	PIN SYMBOL	FUNCTION
5L TO-220		
1	V_{SENSE}	This Kelvin sense pin allows for remote sensing of the output voltage at the load for improved regulation. It is internally connected to the positive input of the voltage sensing error amplifier.
2	Adjust	This pin is connected to the low side of the internally trimmed 1.5% bandgap reference voltage and carries a bias current of about 50uA. A resistor divider from Adj to V_{OUT} and from Adj to ground sets the output voltage. Also, transient response can be improved by adding a small bypass capacitor from this pin to ground.
3	V_{OUT}	This pin is connected to the emitter of the power pass transistor and provides a regulated voltage capable of sourcing 8A of current.
4	V_{CONTROL}	This is the supply voltage for the regulator control circuitry. For the device to regulate, this voltage should be between 1V and 1.30V (depending on the output current) greater than the output voltage. The control pin current will be about 1% of the output current.
5	V_{POWER}	This is the power input voltage. The pin is physically connected to the collector of the power pass transistor. For the device to regulate, this voltage should be between 0.1V and .7V greater than the output voltage depending on output current. The output load current of 8A is supplied through this pin.

Block Diagram

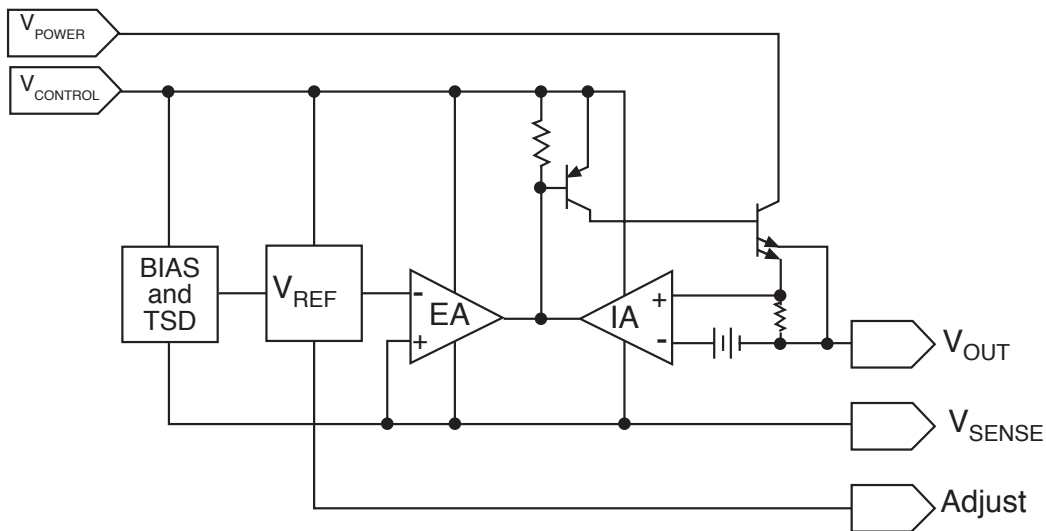

Typical Performance Characteristics

Reference Voltage vs Temperature

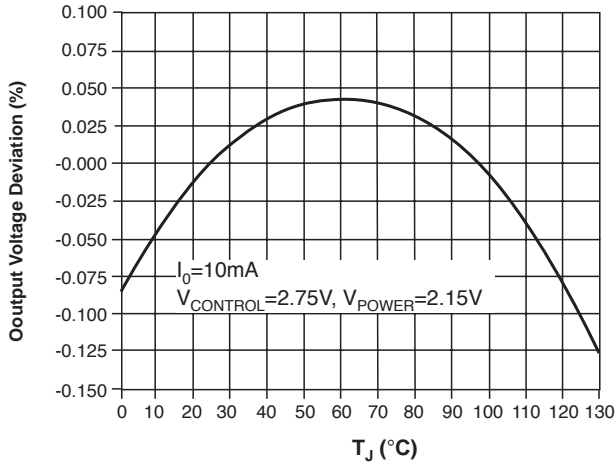

Load Regulation vs Output Current

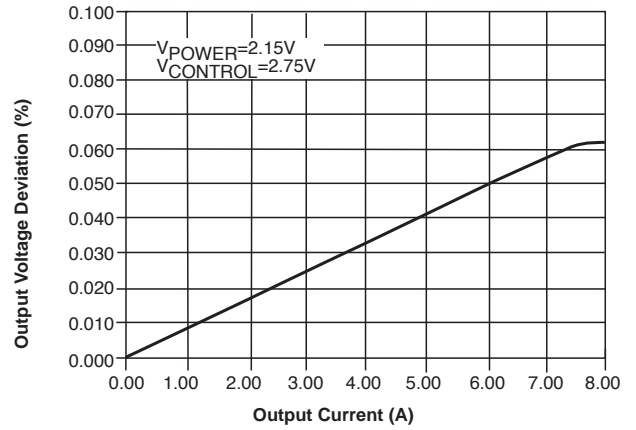

Adjust Pin Current vs Temperature

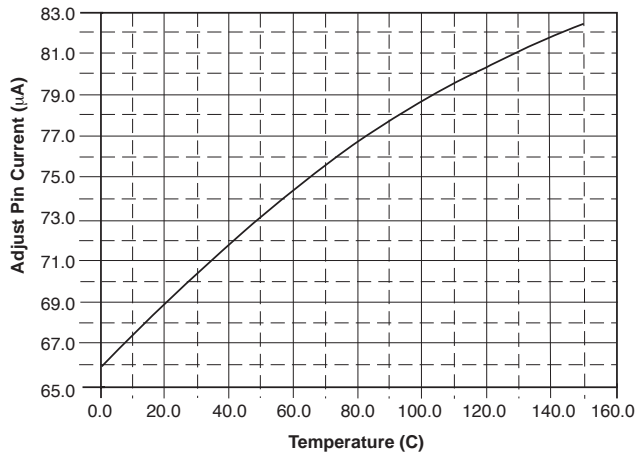

Ripple Rejection vs Frequency

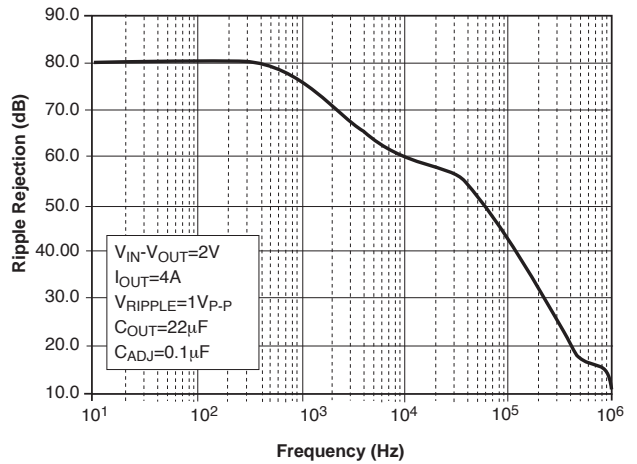

VPOWER Dropout Voltage vs IOUT

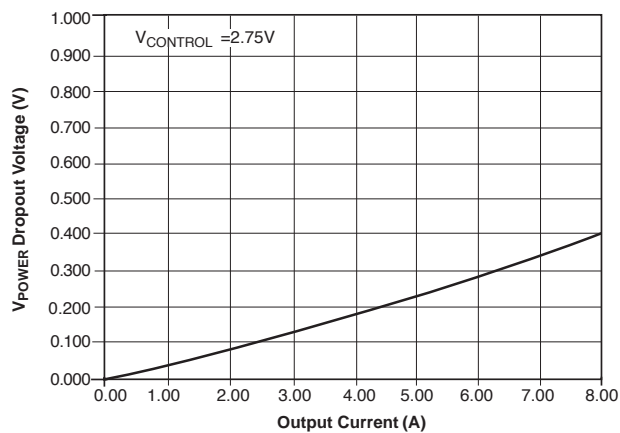

VCONTROL Dropout vs IOUT

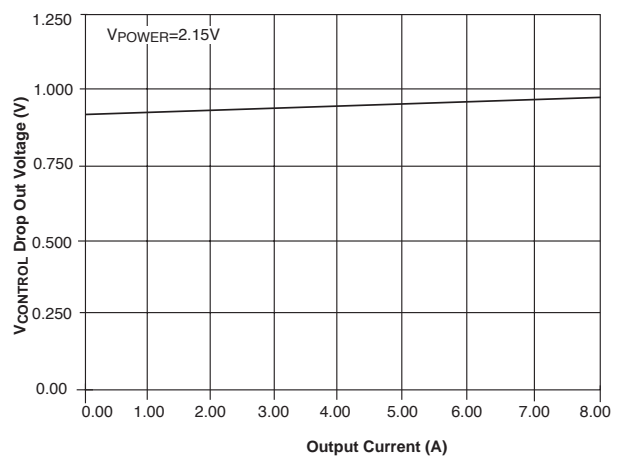

Typical Performance Characteristics: continued

Minimum Load Current vs $V_{CONTROL}-V_{OUT}$

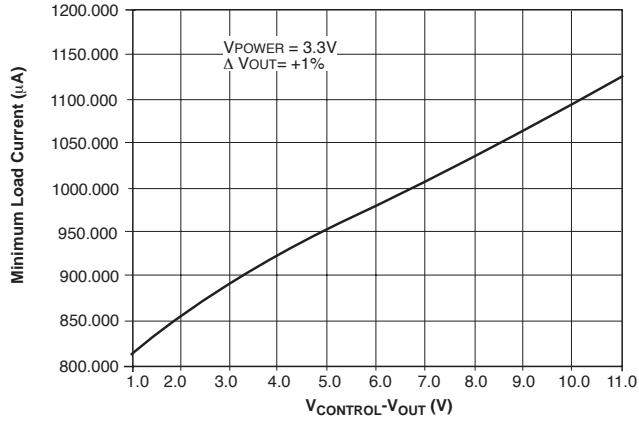

Current Step Transient Response

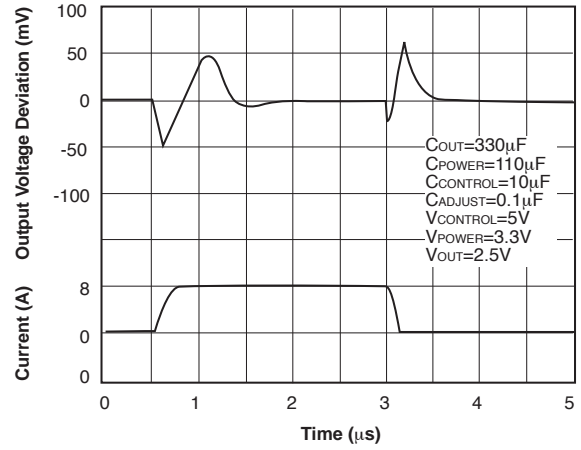

Short Circuit Current vs $V_{POWER}-V_{OUT}$

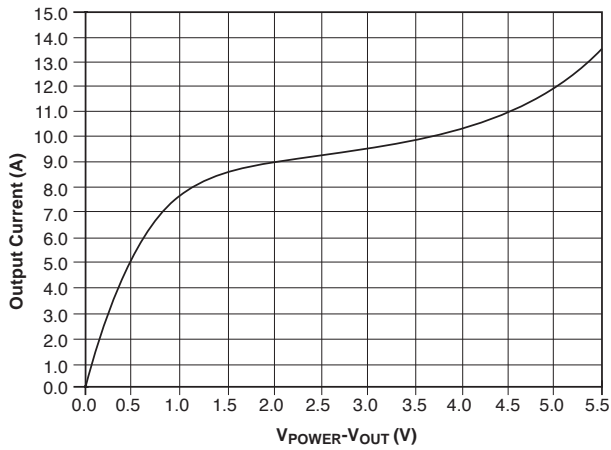

Adjust Pin Current vs Output Current

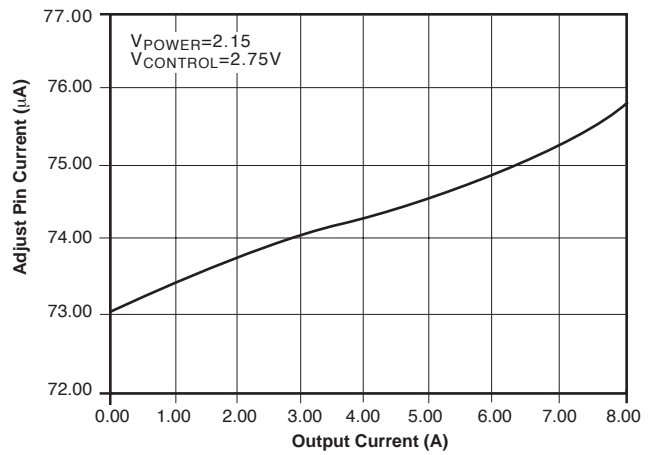

Adjust Pin Current vs $V_{CONTROL}-V_{OUT}$

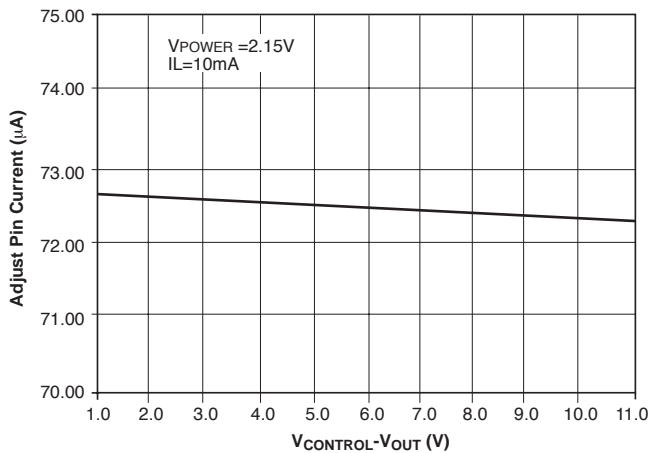

Adjust Pin Current vs $V_{POWER}-V_{OUT}$

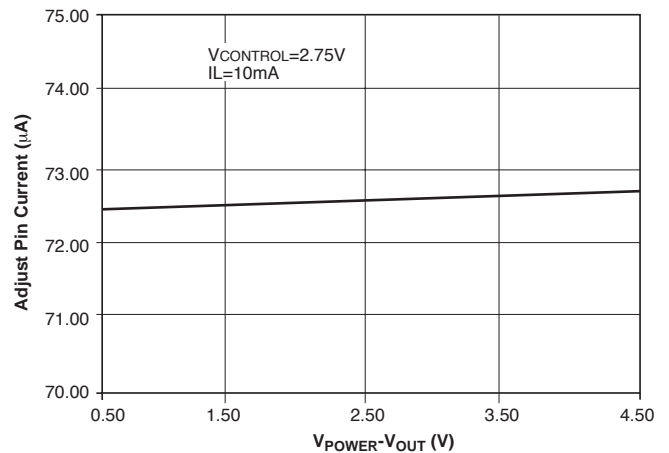

Typical Performance Characteristics: continued

Minimum Load Current vs $V_{POWER}-V_{OUT}$

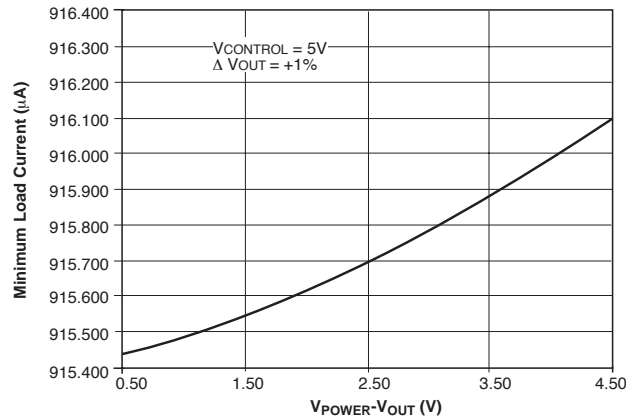

Application Notes

Theory of Operation

The CS5258-1 linear regulator provides adjustable voltages from 1.25V to 5V at currents up to 8A. The regulator is protected against short circuits, and includes a thermal shutdown circuit with hysteresis. The output, which is current limited, consists of a PNP-NPN transistor pair and requires an output capacitor for stability. A detailed procedure for selecting this capacitor is included in the Stability Considerations section.

V_{POWER} Function

The CS5258-1 utilizes a two supply approach to maximize efficiency. The collector of the power device is brought out to the V_{POWER} pin to minimize internal power dissipation under high current loads. $V_{CONTROL}$ provides power for the control circuitry and the drive for the output NPN transistor. $V_{CONTROL}$ should be at least 1V greater than the output voltage. Special care has been taken to ensure that there are no supply sequencing problems. The output voltage will not turn on until both supplies are operating. If the control voltage comes up first, the output current will be typically limited to about 3mA until the power input voltage comes up. If the power input voltage comes up first the output will not turn on at all until the control voltage comes up. The output can never come up unregulated.

The CS5258-1 can also be used as a single supply device with the control and power inputs tied together. In this mode, the dropout will be determined by the minimum control voltage.

Output Voltage Sensing

The CS5258-1 five terminal linear regulator includes a dedicated V_{SENSE} function. This allows for true Kelvin sensing of the output voltage. This feature can virtually eliminate errors in the output voltage due to load regulation. Regulation will be optimized at the point where the sense pin is tied to the output.

Design Guidelines

Adjustable Operation

This LDO adjustable regulator has an output voltage range of 1.25V to 5V. An external resistor divider sets the output voltage as shown in Figure 1. The regulator's voltage sensing error amplifier maintains a fixed 1.253V reference between the output pin and the adjust pin.

A resistor divider network R_1 and R_2 causes a fixed current to flow to ground. This current creates a voltage across R_2 that adds to the 1.253V across R_1 and sets the overall output voltage. The adjust pin current (typically 50 μ A) also flows through R_2 and adds a small error that should be taken into account if precise adjustment of V_{OUT} is necessary. The output voltage is set according to the formula:

$$V_{OUT} = 1.253V \times \left(\frac{R_1 + R_2}{R_1} \right) + R_2 \times I_{ADJ}$$

The term $I_{ADJ} \times R_2$ represents the error added by the adjust pin current.

R_1 is chosen so that the minimum load current is at least 10mA. R_1 and R_2 should be of the same composition for best tracking over temperature. The divider resistors should be located as close to the load as possible.

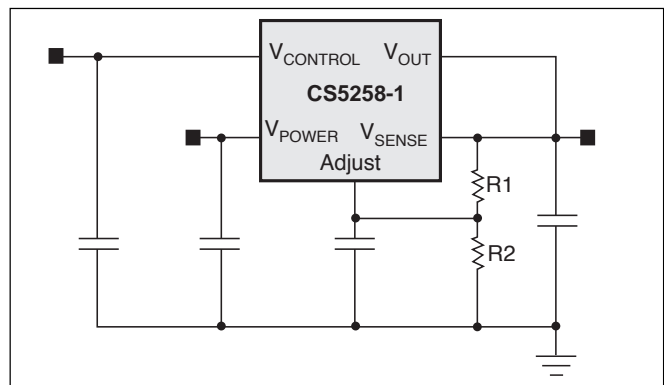

Figure 1: An external resistor divider sets the value of V_{OUT} . The 1.253V reference voltage drops across R_1 .

While not required, a bypass capacitor connected between the adjust pin and ground will improve transient response and ripple rejection. A 0.1μF tantalum capacitor is recommended for “first cut” design. Value and type may be varied to optimize performance vs. price.

Other Adjustable Operation Considerations

The CS5258-1 linear regulator has an absolute maximum specification of 6V for the voltage difference between V_{IN} and V_{OUT}. However, the IC may be used to regulate voltages in excess of 6V. The two main considerations in such a design are the sequencing of power supplies and short circuit capability.

Power supply sequencing should be such that the V_{CONTROL} supply is brought up coincidentally with or before the V_{POWER} supply. This allows the IC to begin charging the output capacitor as soon as the V_{POWER} to V_{OUT} differential is large enough that the pass transistor conducts. As V_{POWER} increases, the pass transistor will remain in dropout, and current is passed to the load until V_{OUT} is in regulation. Further increase in the supply voltage brings the pass transistor out of dropout. In this manner, any output voltage less than 13V may be regulated, provided the V_{POWER} to V_{OUT} differential is less than 6V. In the case where V_{CONTROL} and V_{POWER} are shorted, there is no theoretical limit to the regulated voltage as long as the V_{POWER} to V_{OUT} differential of 6V is not exceeded.

There is a possibility of damaging the IC when V_{POWER}-V_{IN} is greater than 6V if a short circuit occurs. Short circuit conditions will result in the immediate operation of the pass transistor outside of its safe operating area. Over-voltage stresses will then cause destruction of the pass transistor before overcurrent or thermal shutdown circuitry can become active. Additional circuitry may be required to clamp the V_{POWER} to V_{OUT} differential to less than 6V if fail safe operation is required. One possible clamp circuit is illustrated in Figure 2; however, the design of clamp circuitry must be done on an application by application basis. Care must be taken to ensure the clamp actually protects the design. Components used in the clamp design must be able to withstand the short circuit condition indefinitely while protecting the IC.

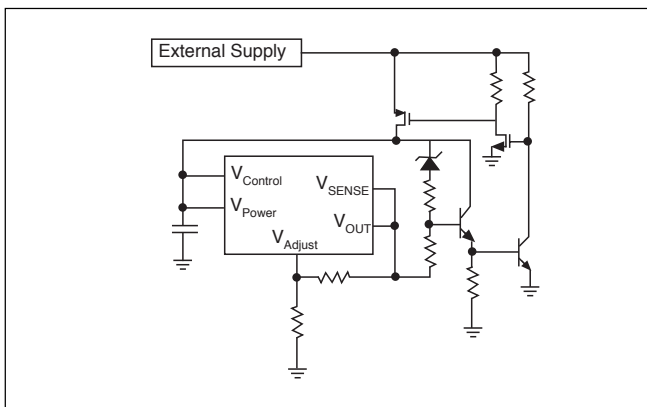

Figure 2: Example clamp circuitry for V_{POWER} - V_{OUT} > 6V.

Stability Considerations

The output compensation capacitor helps determine three main characteristics of a linear regulator: start-up delay, load transient response, and loop stability.

The capacitor value and type is based on cost, availability, size and temperature constraints. A tantalum or aluminum electrolytic capacitor is best, since a film or ceramic capacitor with almost zero ESR can cause instability. The aluminum electrolytic capacitor is the least expensive solution. However, when the circuit operates at low temperatures, both the value and ESR of the capacitor will vary considerably. The capacitor manufacturer’s data sheet provides this information.

A 300μF tantalum capacitor will work for most applications, but with high current regulators such as the CS5258-1 the transient response and stability improve with higher values of capacitor. The majority of applications for this regulator involve large changes in load current so the output capacitor must supply the instantaneous load current. The ESR of the output capacitor causes an immediate drop in output voltage given by:

$$\Delta V = \Delta I \times ESR.$$

For microprocessor applications it is customary to use an output capacitor network consisting of several tantalum and ceramic capacitors in parallel. This reduces the overall ESR and reduces the instantaneous output voltage drop under transient load conditions. The output capacitor network should be as close to the load as possible for the best results.

Protection Diodes

When large external capacitors are used with a linear regulator it is sometimes necessary to add protection diodes. If the input voltage of the regulator gets shorted, the output capacitor will discharge into the output of the regulator. The discharge current depends on the value of the capacitor, the output voltage, and the rate at which V_{CONTROL} drops. In the CS5258-1 regulator, the discharge path is through a large junction and protection diodes are not usually needed. If the regulator is used with large values of output capacitance and the input voltage is instantaneously shorted to ground, damage can occur. In this case, a diode connected as shown in Figure 3 is recommended. Use of the diode has the added benefit of bleeding V_{OUT} to ground if V_{CONTROL} is shorted. This prevents an unregulated output from causing system damage.

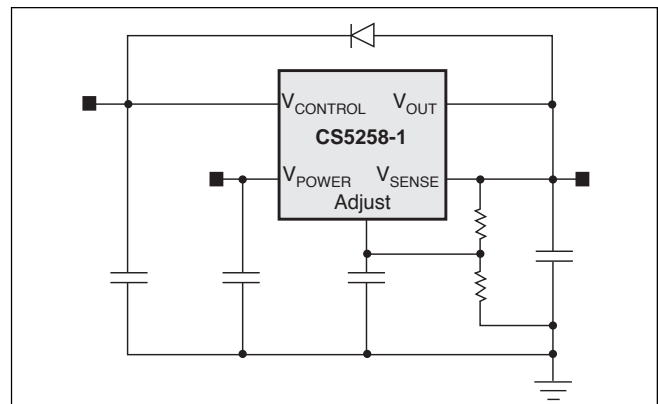

Figure 3: Diode protection against V_{CONTROL} short circuit conditions.

A rule of thumb useful in determining if a protection diode is required is to solve for current

$$I = \frac{C \times V}{T}, \text{ where}$$

- I is the current flow out of the load capacitance when V_{CONTROL} is shorted,
- C is the value of load capacitance
- V is the output voltage, and
- T is the time duration required for V_{CONTROL} to transition from high to being shorted.

If the calculated current is greater than or equal to the typical short circuit current value provided in the specifications, serious thought should be given to the use of a protection diode.

Current Limit

The internal current limit circuit limits the output current under excessive load conditions.

Short Circuit Protection

The device includes short circuit protection circuitry that clamps the output current at approximately two amperes less than its current limit value. This provides for a current foldback function, which reduces power dissipation even further under a direct shorted load.

Thermal Shutdown

The thermal shutdown circuitry is guaranteed by design to activate above a die junction temperature of approximately 150°C and to shut down the regulator output. This circuitry has 25°C of typical hysteresis, thereby allowing the regulator to recover from a thermal fault automatically.

Calculating Power Dissipation and Heat Sink Requirements

High power regulators such as the CS5258-1 family usually operate at high junction temperatures. Therefore, it is important to calculate the power dissipation and junction temperatures accurately to ensure that an adequate heat sink is used. Since the package tab is connected to V_{OUT} on the CS5258-1, electrical isolation may be required for some

applications. Also, as with all high power packages, thermal compound is necessary to ensure proper heat flow. For added safety, this high current LDO includes an internal thermal shutdown circuit

The thermal characteristics of an IC depend on the following four factors: junction temperature, ambient temperature, die power dissipation, and the thermal resistance from the die junction to ambient air. The maximum junction temperature can be determined by:

$$T_{J(\text{max})} = T_{A(\text{max})} + PD_{(\text{max})} \times R_{\theta JA}$$

The maximum ambient temperature and the power dissipation are determined by the design while the maximum junction temperature and the thermal resistance depend on the manufacturer and the package type. The maximum power dissipation for a regulator is:

$$PD_{(\text{max})} = (V_{\text{IN}(\text{max})} - V_{\text{OUT}(\text{min})})I_{\text{OUT}(\text{max})} + V_{\text{IN}(\text{max})}I_{\text{IN}(\text{max})}$$

A heat sink effectively increases the surface area of the package to improve the flow of heat away from the IC and into the surrounding air. Each material in the heat flow path between the IC and the outside environment has a thermal resistance which is measured in degrees per watt. Like series electrical resistances, these thermal resistances are summed to determine the total thermal resistance between the die junction and the surrounding air, $R_{\theta JA}$. This total thermal resistance is comprised of three components. These resistive terms are measured from junction to case ($R_{\theta JC}$), case to heat sink ($R_{\theta CS}$), and heat sink to ambient air ($R_{\theta SA}$). The equation is:

$$R_{\theta JA} = R_{\theta JC} + R_{\theta CS} + R_{\theta SA}$$

The value for $R_{\theta JC}$ is 1.4°C watt for the CS5258-1 in the TO-220 package. For a high current regulator such as the CS5258-1 the majority of heat is generated in the power transistor section. The value for $R_{\theta SA}$ depends on the heat sink type, while the $R_{\theta CS}$ depends on factors such as package type, heat sink interface (is an insulator and thermal grease used?), and the contact area between the heat sink and the package. Once these calculations are complete, the maximum permissible value of $R_{\theta JA}$ can be calculated and the proper heat sink selected. For further discussion on heat sink selection, see our Cherry application note "Thermal Management for Linear Regulators."

Package Specification

CS5258-1

PACKAGE DIMENSIONS IN mm (INCHES)

PACKAGE THERMAL DATA

Thermal Data		5L TO-220	
$R_{\theta JC}$	typ	1.4	$^{\circ}\text{C}/\text{W}$
$R_{\theta JA}$	typ	50	$^{\circ}\text{C}/\text{W}$

5 Lead TO-220 (T) Straight

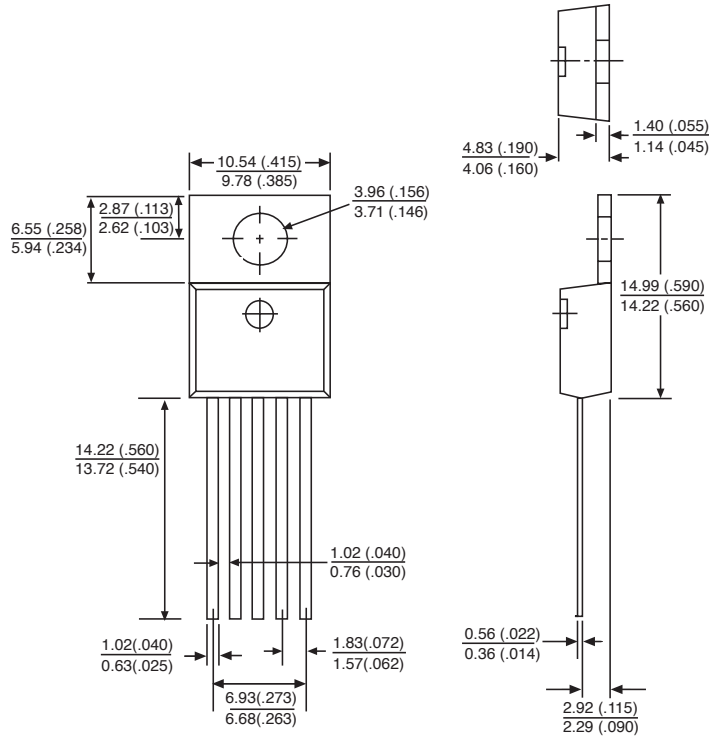

Ordering Information

Part Number	Description
CS5258-1GT5	5L TO-220 Straight

Cherry Semiconductor Corporation reserves the right to make changes to the specifications without notice. Please contact Cherry Semiconductor Corporation for the latest available information.